



SERVICE MANUAL

MODEL 4194A

**IMPEDANCE/GAIN-PHASE
ANALYZER**

(Including Options 001,350 and 375)

SERIAL NUMBERS

This manual applies directly to instruments whose serial number prefix is 2617J and whose ROM-based firmware is version 2.2.

With the changes described in Appendix A, this manual also applies to instruments whose serial number prefix is 2614J and below, and whose ROM-based firmware is version 2.0 and 2.1.

For additional important information about serial numbers, read **INSTRUMENTS COVERED BY MANUAL** in Section 1 of the Operation Manual.

© COPYRIGHT: YOKOGAWA-HEWLETT-PACKARD, LTD., 1986
9-1, TAKAKURA-CHO, HACHIOJI-SHI, TOKYO, JAPAN

DIGITALLY REMASTERED
OUT OF PRINT
TEST EQUIPMENT MANUAL SCANS

By

ArtekManuals

(formerly known as ArtekMedia and Artekmedia.com)
7102 VALRIE LANE, RIVERVIEW, FL 33569

www.artekmanuals.com

“High resolution scans of obsolete technical manuals”

**REMOVAL OF THIS DISCLAIMER IS IN VIOLATION ARTEKMANUALS
DERIVATIVE COPYRIGHTS. DUPLICATION OR MODIFICATION OF THIS
DIGITAL DOCUMENT WITHOUT PRIOR CONSENT IS NOT PERMITTED**

If your looking for a quality scanned technical manual in PDF format please visit our WEB site at www.ArtekManuals.com or drop us an email at Manuals@ArtekManuals.com

If you don't see the manual you need on the list drop us a line anyway we may still be able to point you to other sources. If you have an existing manual you would like scanned please write for details. This can often be done very reasonably in consideration for adding your manual to our library.

Typically the scans in our manuals are done as follows;

- 1) Typed text pages are typically scanned in black and white at 300 dpi.
- 2) Photo pages are typically scanned in gray scale mode at 450 dpi
- 3) Schematic diagram pages are typically scanned in black and white at 600 dpi or Gray-scale @450dpi depending on the characteristics.
- 4) All manuals are text searchable and all manuals are fully bookmarked

All data is guaranteed for life (yours or mine ... which ever is shorter). If for ANY REASON your file becomes corrupted, deleted or lost, ArtekManuals will replace the file for the price of shipping, or free via FTP download.

Thanks



Founder and CEO
Artek Media
ArtekManuals
Outsource-Options

HOW TO USE THIS MANUAL

The Operation and Service Manuals are necessary for servicing the 4194A Impedance/Gain-Phase Analyzer. The Operation Manual is supplied with the 4194A and the Service Manual is sold separately. The contents of each manual are shown below.

4194A Operation Manual

Section 1	General Information
Section 2	Installation
Section 3	Operation
Section 4	Performance Tests
Appendices	

4194A Service Manual

Section 5	Adjustments
Section 6	Replaceable Parts
Section 7	Manual Changes
Section 8	Service

Section 8 of this manual is divided into three parts which are separated by colored pages. The first part contains general service-related information, basic operating theory, block diagram level explanations, and PC board level troubleshooting. The second part contains service sheets for the Control Unit. The last part contains service sheets for the Measurement Unit.

The upper unit, including the CRT, is the Control Unit, and the lower unit, on which measurement terminals are located, is the Measurement Unit.

CONTENTS

SECTION 5 ADJUSTMENTS

- 5-1. Introduction 5-1
- 5-2. Safety Considerations 5-1
- 5-3. Test Equipment 5-2
- 5-4. Adjustable and Factory Selected Components 5-2
- 5-5. Adjustment Interactions 5-2
- 5-6. Adjustment Locations 5-2
- 5-7. Initial Operating Procedure 5-2
- 5-8. Switching Power Supply Adjustments 5-9
- 5-9. High Stability Oscillator Adjustments (Opt. 001) 5-12
- 5-10. Local Voltage Regulator Adjustment 5-14
- 5-11. 160MHz Reference Adjustments 5-15
 - 5-11-1. 80MHz VCXO Level Adjustment 5-15
 - 5-11-2. 80MHz VCXO Frequency Adjustment 5-16
 - 5-11-3. 160MHz Reference Signal Level Adjustment 5-18
- 5-12. 160MHz-IF Reference Adjustments 5-19
 - 5-12-1. 80MHz-IF/2 VCXO Level and Var. Range Adjustment 5-19
 - 5-12-2. 160MHz-IF Signal Level Adjustment 5-21
 - 5-12-3. IF Level Adjustment 5-22
- 5-13. Fractional N PLL Adjustments 5-23
 - 5-13-1. VCO Center Frequency Adjustment 5-23
 - 5-13-2. VCO 100kHz Spurious Rejection Adjustment 5-25
 - 5-13-3. API Adjustment 5-26
- 5-14. Bridge Adjustments 5-29
 - 5-14-1. A23 Local Oscillator Feedthrough Adjustment 5-29
 - 5-14-2. L_{CUR} Output Adjustment 5-31
 - 5-14-3. Integrator Offset Fine Adjustment 5-33

CONTENTS (cont.)

- 5-15. **Frequency Converter/Test Signal Amplifier Adjustments 5-35**
 - 5-15-1. 160MHz Notch Filter Adjustment 5-35
 - 5-15-2. Mixer Local Level Adjustment 5-36
 - 5-15-3. Test Signal Level Adjustment 5-39
 - 5-15-4. Power Amplifier Distortion Adjustment 5-40
 - 5-15-5. Pre-amplifier Output Flatness Adjustment 5-41
 - 5-15-6. RF/AF Gain Tracking Adjustment 5-42
- 5-16. **DC Bias Adjustments 5-44**
- 5-17. **Gain-Phase Input Amplifier Adjustments 5-46**
 - 5-17-1. Input Amplifier DC Offset Adjustment 5-46
 - 5-17-2. Input Capacitance Adjustment 5-47
 - 5-17-3. Internal Attenuator Adjustment 5-49
- 5-18. **Process Amplifier Adjustment 5-53**
 - 5-18-1. IF Band-Pass Filter Coarse Adjustments 5-53
 - 5-18-2. Mixer Local Feedthrough Adjustment (Gain-Phase) 5-56
 - 5-18-3. Mixer Local Feedthrough Adjustment (Impedance) 5-57
 - 5-18-4. IF Band-Pass Filter Fine Adjustments 5-58
 - 5-18-5. IF Gain Adjustment 5-60
- 5-19. **Phase Detector Tracking Adjustment 5-62**
- 5-20. **Updating Data 5-63**
 - 5-20-1. Phase Tracking Test Data 5-63
 - 5-20-2. Calibration Data 5-64
- 5-21. **Display Adjustments 5-65**
 - 5-21-1. Local Voltage Regulator Adjustment 5-65
 - 5-21-2. Horizontal Position Coarse Adjustment 5-66
 - 5-21-3. CRT Cutoff Adjustment 5-68
 - 5-21-4. Vertical and Horizontal Hold Adjustments 5-69
 - 5-21-5. Display Pos., Size, and Pincushion Adjustments 5-70
 - 5-21-6. White Balance Adjustment 5-71
 - 5-21-7. Maximum Intensity Adjustment 5-72
 - 5-21-8. Focus, Convergence, and Intensity Adjustment 5-72

CONTENTS (cont.)

**SECTION 6
REPLACEABLE PARTS**

- 6-1. Introduction 6-1
- 6-2. Abbreviations 6-1
- 6-3. Replaceable Parts List 6-1
- 6-4. Ordering Information 6-1
- 6-5. Direct Mail Ordering 6-2

**SECTION 7
MANUAL CHANGES**

- 7-1. Introduction 7-1
- 7-2. Manual Changes 7-1

**SECTION 8
SERVICE**

- 8-1. Introduction 8-1
- 8-2. Safety Considerations 8-1
- 8-3. Theory of Operation 8-1
- 8-4. Recommended Test Equipment 8-2
- 8-5. Troubleshooting 8-2
- 8-6. Repair 8-2
- 8-7. Fasteners 8-2
- 8-8. Schematic Diagram Symbols 8-2
- 8-9. Assembly Designations 8-5
- 8-10. Assembly Locations 8-5
- 8-11. Disassembly 8-8
- 8-12. Product Safety Checks 8-11
- 8-13. Signal Names 8-12
- 8-14. Basic Operating Theory 8-19
- 8-15. Impedance Measurement Theory 8-19

CONTENTS (cont.)

- 8-16. **Ammeter Circuit 8-20**
- 8-17. **Auto-Balance Bridge Circuitry 8-21**
- 8-18. **Vector Voltage Detector 8-23**
- 8-19. **Vector Impedance Calculation 8-25**
- 8-20. **Gain-Phase Measurement Theory 8-26**
- 8-21. **Gain-Phase Calculation 8-27**
- 8-22. **Block Diagram Discussion 8-27**
- 8-23. **Oscillator Section 8-27**
- 8-24. **VVD Section 8-28**
- 8-25. **Digital Control Section 8-31**
- 8-26. **4194A Self Test Instructions 8-32**
 - 8-26-1. **How to RUN Self Test 8-32**
 - 8-26-2. **Self Test Softkey Meanings 8-32**
- 8-27. **Power-on Self Test 8-48**
- 8-28. **Hardware Related Error Messages 8-51**
- 8-29. **Faulty Board Isolation 8-51**

TABLES

5-1.	Recommended Test Equipment	5-4
5-2.	Adjustable Components	5-5
5-3.	Factory Selected Components	5-6
5-4.	Required Adjustments	5-8
5-5.	Power Supply Voltage Confirmation Check Limits	5-11
5-6.	L39 and L40 Selection	5-17
5-7.	80MHz-IF/2 VCXO Variable Range Adjustment	5-20
5-8.	Test Signal Mixer Local Level Adjustment Frequencies	5-37
5-9.	Local Frequency Mixer Local Level Adjustment Frequencies	5-38

6-1.	List of Reference Designators and Abbreviations	6-2
6-2.	Component Manufacturers	6-3
6-3.	Replaceable Parts	6-4
6-4.	Board Mounted Hardware	6-145
6-5.	Coaxial Cable Assemblies	6-148
6-6.	Flat Cable Assemblies	6-148
6-7.	Other Cables	6-148
6-8.	Front Panel Components	6-149
6-9.	Control Unit Front Panel Components	6-150
6-10.	Control Unit Rear Panel Components	6-151
6-11.	CRT Components	6-153
6-12.	Measurement Unit Front Panel Components	6-154
6-13.	Measurement Unit Rear Panel Components	6-155

7-1.	Manual Changes by Serial Number	7-1
7-2.	Parts Information	7-13

8-1.	Assembly Identification	8-4
8-2.	Signal Names	8-12
8-3.	4194A's Self Test Menus	8-33
8-4.	Error Messages	8-51
A4-1.	A4 Troubleshooting Data (1 of 2)	8-66
A4-1.	A4 Troubleshooting Data (2 of 2)	8-67
A5-1.	A5 Troubleshooting Data	8-71
A6-1.	A6 Troubleshooting Data (1 of 3)	8-74
A6-1.	A6 Troubleshooting Data (2 of 3)	8-75
A6-1.	A6 Troubleshooting Data (3 of 3)	8-76
A7-1.	A7 Troubleshooting Aids	8-81
A8-1.	A8 Troubleshooting Aids (1 of 2)	8-87
A8-1.	A8 Troubleshooting Aids (2 of 2)	8-88
A9-1.	A9 Averaging and Relative Detection Phase	8-93
A9-2.	A9 Troubleshooting Aids	8-97
A9-3.	A9 Troubleshooting Data (1 of 2)	8-98
A9-3.	A9 Troubleshooting Data (2 of 2)	8-99
A10-1.	A10 Troubleshooting Aids	8-104
A10-2.	A10 Troubleshooting Data (1 of 3)	8-105
A10-2.	A10 Troubleshooting Data (2 of 3)	8-106
A10-2.	A10 Troubleshooting Data (3 of 3)	8-107
A11-1.	A11 Troubleshooting Aids	8-112
A11-2.	A11 Troubleshooting Data (1 of 3)	8-113
A11-2.	A11 Troubleshooting Data (2 of 3)	8-114
A11-2.	A11 Troubleshooting Data (3 of 3)	8-115

TABLES (cont.)

A20-1.	A20 OSC Level versus Attenuator setting	8-122
A20-2.	A20 Troubleshooting Aids	8-122
A20-3.	A20 Troubleshooting Data	8-123
A21-1.	A21 (31) Troubleshooting Aids (1 of 2)	8-128
A21-1.	A21 (31) Troubleshooting Aids (2 of 2)	8-129
A21-2.	A21 (31) Troubleshooting Data (1 of 3)	8-130
A21-2.	A21 (31) Troubleshooting Data (2 of 3)	8-131
A21-2.	A21 (31) troubleshooting Data (3 of 3)	8-132
A22-2.	A22 Troubleshooting Aids (1 of 2)	8-150
A22-2.	A22 Troubleshooting Aids (2 of 2)	8-151
A22-3.	A22 Troubleshooting Data (1 of 2)	8-152
A22-3.	A22 Troubleshooting Data (2 of 2)	8-153
A23-1.	A23 Troubleshooting Data	8-158
A24-1.	Attenuator Setting versus OSC Level	8-161
A24-2.	A24 Troubleshooting Data	8-162

ILLUSTRATIONS

- 5-1. Switching Power Supply Adjustment Setup 5-9
- 5-2. Switching Power Supply Adjustment and Test Point Locations 5-11
- 5-3. High Stability Oscillator Adjustment Setup 5-12
- 5-4. Local Voltage Regulator Adjustment Setup 5-14
- 5-5. 80MHz VCXO Level Adjustment Setup 5-15
- 5-6. 80MHz VCXO Level Frequency Adjustment Setup 5-16
- 5-7. 160MHz Signal Output Level Adjustment Setup 5-18
- 5-8. 80MHz-IF/2 VCXO Level and Variable Range Adjustment Setup 5-19
- 5-9. 160MHz-IF Signal Level Adjustment Setup 5-21
- 5-10. IF Level Adjustment Setup 5-22
- 5-11. VCO Center Frequency Adjustment Setup 5-23
- 5-12. VCO Center Frequency Adjustment Locations 5-24
- 5-13. VCO 100kHz Spurious Rejection and API Adjustment Setup 5-25
- 5-14. Incorrectly Adjusted VCO Output 5-26
- 5-15. Properly Adjusted VCO Output 5-26
- 5-16. Incorrectly Adjusted API1 Spectrum 5-27
- 5-17. Incorrectly Adjusted API2 Spectrum 5-27
- 5-18. Incorrectly Adjusted API3 Spectrum 5-28
- 5-19. Properly Adjusted Spectrum 5-28
- 5-20. A23 Local Oscillator Adjustment Setup 5-29
- 5-21. A23 Local Oscillator Adjustment Locations 5-30
- 5-22. L_{CUR} Output Adjustment Setup 5-31
- 5-23. L_{CUR} Output Adjustment Locations 5-33
- 5-24. Integrator Offset Fine Adjustment Setup. 5-33
- 5-25. 160MHz Notch Filter Adjustment Setup 5-35
- 5-26. Mixer Local Level Adjustment Setup 5-36
- 5-27. Test Signal Level and Flatness Adjustment Setup 5-39
- 5-28. Power Amplifier Distortion Adjustment Setup 5-40
- 5-29. RF/AF Gain Tracking Adjustment Setup 5-42
- 5-30. DC Bias Adjustment Setup 5-44
- 5-31. Input Amplifier DC Offset Adjustment Setup 5-46
- 5-32. Input Capacitance Adjustment Setup 5-47
- 5-33. Internal Attenuation Adjustment Setup 5-49
- 5-34. IF Band Pass Filter Coarse Adjustment Setup 5-53
- 5-35. Notch Filter Adjustment 5-55
- 5-36. Pass Band Adjustment 5-56
- 5-37. Mixer Local Feedthrough Adjustment Setup 5-56
- 5-38. IF Band Pass Filter Fine Adjustment Setup 5-58
- 5-39. Properly Adjusted Trace 5-59
- 5-40. Incorrectly Adjusted Trace 5-60
- 5-41. IF Gain Adjustment Setup 5-60
- 5-42. Setup for Writing Phase Tracking Test Data 5-63
- 5-43. Local Voltage Regulator Adjustment Setup 5-65
- 5-44. Horizontal Position Coarse Adjustment Setup 5-66
- 5-45. Horizontal Position Coarse Adjustment 5-67
- 5-46. CRT Cutoff Adjustment Setup 5-68
- 5-47. Vertical and Horizontal Hold Adjustment Setup 5-69
- 5-48. Display Position, Size, and Pincushion Adjustment Setup 5-70
- 5-49. White Balance Adjustment Setup 5-71
- 5-50. Maximum Intensity Adjustment Setup 5-72
- 5-51. Focus and Convergence Adjustment 5-73

ILLUSTRATIONS (cont.)

- 6-1. Major Mechanical Parts--Exploded View

- 7-1. A7 Board Component Locations Changes 7-3
- 7-2. A26 Board Schematic Changes 7-4
- 7-3. A21A1 Board Component Location Changes 7-5
- 7-4. A21A1 Board Schematic Changes 7-6
- 7-5. A21A2 Board Component Location Changes 7-7
- 7-6. A21A2 Board Schematic Changes 7-8
- 7-7. A31A1 Board Component Location Changes 7-9
- 7-8. A31A1 Board Schematic Changes 7-10
- 7-9. A31A2 Board Component Location Changes 7-11
- 7-10. A31A2 Board Schematic Changes 7-12

- 8-1. Schematic Diagram Note 8-3
- 8-2. Assembly Locations (1 of 3) 8-5
- 8-2. Assembly Locations (2 of 3) 8-6
- 8-2. Assembly Locations (3 of 3) 8-7
- 8-3. Disassembly (1 of 3) 8-8
- 8-3. Disassembly (2 of 3) 9
- 8-3. Disassembly (3 of 3) 8-10
- 8-4. Voltage-Current Ratio Measurement Method 8-19
- 8-5. Current-to-Voltage Conversion Method 8-20
- 8-6. Two Oscillator Model of the Autobalance Bridge 8-21
- 8-7. Auto-Balanced Bridge Circuit 8-21
- 8-8. Auto-Balanced Bridge Operating Principle 8-22
- 8-9. VDD Operating Principle (1 of 2) 8-23
- 8-9. VDD Operating Principle (2 of 2) 8-24
- 8-10. Impedance Measurement Circuit 8-25
- 8-11. Typical Network Analyzer Construction 8-26
- 8-12. Gain-Phase Measurement Circuit Simplified Block Diagram 8-26
- 8-13. Simplified Block Diagram Discussion 8-28
- 8-14. Analog Measurement Circuit Block Diagram 8-30
- 8-15. 4194A's VVD Section 8-29
- 8-16. Digital Control Section Block Diagram 8-31
- 8-17. Selftest Instruction (1 of 15) 8-34
- 8-17. Selftest Instructions (2 of 15) 8-35
- 8-17. Selftest Instructions (3 of 15) 8-36
- 8-17. Selftest Instructions (4 of 15) 8-37
- 8-17. Selftest Instructions (5 of 15) 8-38
- 8-17. Selftest Instructions (6 of 15) 8-39
- 8-17. Selftest Instructions (7 of 15) 8-40
- 8-17. Selftest Instructions (8 of 15) 8-41
- 8-17. Selftest Instructions (9 of 15) 8-42
- 8-17. Selftest Instructions (10 of 15) 8-43
- 8-17. Selftest Instructions (11 of 15) 8-44
- 8-17. Selftest Instructions (12 of 15) 8-45
- 8-17. Selftest Instructions (13 of 15) 8-46
- 8-17. Selftest Instructions (14 of 15) 8-47
- 8-17. Selftest Instructions (15 of 15) 8-48
- 8-18. Power-On Selftest Error Messages (1 of 2) 8-49
- 8-18. Power-On Selftest Error Messages (2 of 2) 8-50
- 8-19. Power-On Selftest LED Indications 8-51

ILLUSTRATIONS (cont.)

8-20.	Faulty Board Isolation Flow Diagram (1 of 8)	8-52
8-20.	Faulty Board Isolation Flow Diagram (2 of 8)	8-53
8-20.	Faulty Board Isolation Flow Diagram (3 of 8)	8-54
8-20.	Faulty Board Isolation Flow Diagram (4 of 8)	8-55
8-20.	Faulty Board Isolation Flow Diagram (5 of 8)	8-56
8-20.	Faulty Board Isolation Flow Diagram (6 of 8)	8-57
8-20.	Faulty Board Isolation Flow Diagram (7 of 8)	8-58
8-20.	Faulty Board Isolation Flow Diagram (8 of 8)	8-59
PS-1.	Power Supply System Diagram	8-62
A4-1.	A4 Board and A17 Board Block Diagram	8-64
A5-1.	A5 Board Block Diagram	8-69
A7-1.	Shared RAM Block Diagram	8-80
A7-2.	Shared RAM Timing Chart	8-80
A8-1.	A-D Converter Timing Chart	8-84
A8-2.	Fraction N Loop Setup Example	8-85
A9-1.	A9 Board Block Diagram	8-92
A9-2.	Double Wave Phase Detection Example	8-93
A9-3.	Multislope A-D Converter	8-94
A9-4.	A-D Converter Timing Diagram	8-95
A9-5.	Integration Time and Measurement Frequency	8-96
A10-1.	A10 Board Block Diagram	8-101
A10-2.	Test Frequency and IF Relationship	8-102
A11-1.	A11 Board Block Diagram	8-109
A11-2.	Conventional PLL Block Diagram	8-109
A11-3.	Variable Phase PLL with a Current Source	8-110
A11-4.	Fractional N-Loop Timing Diagram	8-111
A20-1.	A20 Board Block Diagram	8-120
A20-2.	Range Resistor Selection	8-121
A21-1.	A21/31 Board Block Diagram	8-126
A22-1.	A22 Board Block Diagram	8-143
A22-2.	OSC Level Controller	8-143
A22-3.	Serial Data Check Procedure (1 of 5)	8-145
A22-3.	Serial Data Check Procedure (2 of 5)	8-146
A22-3.	Serial Data Check Procedure (3 of 5)	8-147
A22-3.	Serial Data Check Procedure (4 of 5)	8-148
A22-3.	Serial Data Check Procedure (5 of 5)	8-149
A23-1.	A23 Board Block Diagram	8-157
A24-1.	A24/34 Board Block Diagram	8-160

SECTION 5

ADJUSTMENTS

5-1. INTRODUCTION

This section describes the adjustments and checks required to ensure that the 4194A meets its published specifications after repairs have been made. These adjustments and checks should be performed along with periodic maintenance to keep the instrument in optimum operating condition. The recommended adjustment cycle is twice a year. If proper performance cannot be achieved after adjustments have been made, refer to the troubleshooting procedures in Section 8.

Note

Allow the 4194A to warm up for at least 30 minutes before you perform any adjustments.

5-2. SAFETY CONSIDERATIONS

This manual contains Notes, **CAUTIONS**, and **WARNINGS** which must be followed to ensure the safety of the operator and to keep the instrument in a safe and serviceable condition. The adjustments covered in this section should be performed by qualified service personnel only.

WARNING

ANY INTERRUPTION OF THE PROTECTIVE (GROUND) CONDUCTOR (INSIDE OR OUTSIDE THE INSTRUMENT) OR DISCONNECTION OF THE PROTECTIVE EARTH TERMINAL IS LIKELY TO MAKE THE INSTRUMENT DANGEROUS. INTENTIONAL INTERRUPTION, FOR ANY REASON, IS PROHIBITED.

The removal or opening of covers for the adjustment or removal of parts other than those which are accessible by hand will expose live circuits.

Remember that even though you may have shut the instrument off and unplugged it, capacitors in the 4194A may retain their charges for quite a while.

WARNING

THE ADJUSTMENTS DESCRIBED IN THIS SECTION ARE PERFORMED WITH POWER APPLIED AND PROTECTIVE COVERS REMOVED. DANGEROUS VOLTAGES EXIST AT MANY POINTS AND CAN RESULT IN SERIOUS PERSONAL INJURY.

5-3. TEST EQUIPMENT

Table 5-1 lists the test equipment required to perform the adjustments described in this section. Use only calibrated test instruments when adjusting the 4194A. If the recommended test equipment is not available, equipment with specifications that equal or surpass those of the recommended equipment can be used.

5-4. ADJUSTABLE AND FACTORY SELECTED COMPONENTS

Table 5-2 lists the 4194A's adjustable components, gives the name of the adjustment related to each component, and provides a brief description of each adjustment.

Several 4194A components are selected at the factory. Table 5-3 lists these components, gives their nominal values, and provides a reference for information concerning the effect each component has on instrument performance. On the schematic diagrams of Section 8, factory selected components are identified by an asterisk (*) next to the component's reference designator. Only nominal values are given for these components.

5-5. ADJUSTMENT INTERACTIONS

A number of 4194A adjustments are interactive. If you repair or replace a 4194A assembly, be sure to perform the related adjustment(s) in the sequence given. Table 5-4 lists the adjustments required for each assembly repaired or replaced. Ignoring or changing the order of adjustments will make it impossible to obtain optimum performance.

Note

The CRT display adjustments described in paragraph 5-21 do not interact with any other adjustments, but are affected by power supply adjustments. You can, therefore, perform CRT display adjustments at any time after you've adjusted the power supply.

5-6. ADJUSTMENT LOCATIONS

Each adjustment procedure contains a figure to help you locate the adjustment points and factory selected components, and to identify the required connectors and other related equipment for each adjustment procedure.

5-7. INITIAL OPERATING PROCEDURE

Before you start, perform the BASIC OPERATING CHECK and the DISASSEMBLY procedures given in the following paragraphs to prepare the 4194A for adjustments. The 4194A must be initialized (set to its initial control settings), as described in Section 3, before each adjustment. Exceptions to these settings will be noted as they occur. After you complete an adjustment, be sure to initialize your 4194A.

Note

The 4194A is initialized, except for the setting of the CABLE LENGTH (0m/1m) switch, when it is turned on and when an RST command is initiated from the keyboard or received via the HP-IB.

BASIC OPERATING CHECK

Be sure that the 4194A's rear panel line voltage selector switches are set to the line voltage in your area. Turn the 4194A on and let it warm up for at least 30 minutes. After the warm-up period, initialize the instrument. If the 4194A fails its self test or if you can't initialize it, refer to the troubleshooting procedures in Section 8.

DISASSEMBLY, TOP/BOTTOM COVER REMOVAL, AND INTERCONNECTIONS

To gain access to the adjustment points, perform the following procedure.

1. Remove the cables from the rear panels.
2. Remove the lock link-feet from the rear frames.
3. Separate the Control Unit from the Measurement Unit.
4. Place the Control Unit next to the Measurement Unit.
5. Fully loosen the cover retaining screw at the rear of the Control Unit's top cover.
6. Slide the top cover towards the rear and lift it off.
7. Remove the Measurement Unit's top and bottom covers in a similar manner.
8. Interconnect the Control and Measurement Units' rear panel connectors with the 70cm cables included in the 16349A Product Support Package.

WARNING

TO PROTECT AGAINST POSSIBLE ELECTRICAL SHOCK HAZARDS, USE INSULATED TOOLS FOR ALL ADJUSTMENTS.

Table 5-1. Recommended Test Equipment

Equipment	Specifications	Recommended Model	Use
Frequency Counter	Maximum Frequency: >260MHz Resolution: <100mHz @ 10MHz Accuracy: <<1ppm Max. Operating Input: >20V peak	HP 5385A Opt. 004	A
Digital Voltmeter	DCV Resolution: <0.1mV ACV Freq. Range: 10Hz to 250kHz	HP 3456A	A,T
Power Meter/ Power Sensor	Nominal Impedance: 50Ω Accuracy: 0.02dB	HP 436A/ HP 8482A	A
Oscilloscope	Bandwidth: 100MHz Sensitivity: 5mV Min.	HP 1740A	A,T
Spectrum Analyzer	Frequency: 100Hz to 500MHz	HP 8568B	A,T
	Frequency: 20Hz to 1MHz Tracking Generator Capability	HP 3585A	A,T
Capacitance Meter	Measurement Frequency: 100kHz Range: 30pF, Accuracy: ±5% Grounded Measurement Capability	HP 4332A/ HP 16138A	A
HP-IB Controller		HP 9826	A
50Ω to 75Ω Pad*		HP 11852A	A
Signature Multi- meter		HP 5005B	T
Product Support Package		HP 16349A	A,T
Probe	1:1, 50Ω 1:1, 1MΩ 10:1, 1MΩ	HP 10026A HP 10021A HP 10040A	A,T
Cables	BNC (m)-to-Dual Banana Plug BNC (m)-to-BNC (m), 30cm BNC (m)-to-BNC (m), 61cm SMB (f)-to-BNC (m) BNC, Four-terminal pair	HP 11035A 8120-1838 8120-1839 04280-65002 16074-61600	A,T
Feedthrough Terminations	BNC, 50Ω BNC, 75Ω *	04192-61002 04192-61003	A,T
Adapters	N (f)-to-BNC (m), 50Ω N (m)-to-BNC (f), 50Ω N (f)-to BNC (m), 75Ω * N (m)-to-BNC (f), 75Ω *	1250-0077 1250-0780 1250-1534 1250-1535	A,T

* Required for Option 375 units only.

Table 5-2. Adjustable Components (1 of 3)

Adjustable Component	Adjustment Name	Description
A2R7	V-ADJ	Switching power supply output voltage adjustment
A2R8	FRQ-ADJ	Switching power supply frequency adjustment
Jumper	H Position	CRT horizontal position adjustment
A4L1	H SIZE	CRT horizontal size adjustment
A4R45	PIN	Pincushion distortion adjustment
A4R46	V SIZE	CRT vertical size adjustment
A4R47	V HOLD	CRT vertical hold adjustment
A4R48	H HOLD	CRT horizontal hold adjustment
A4R49	V POS	CRT vertical position adjustment
A4R67	VOLT ADJ	Local voltage regulator adjustment
A5R4 A5R11	B CUTOFF G CUTOFF	Cutoff voltage adjustment
A5R30 A5R31 A5R32 A5R33	BH BL GH GL	White balance adjustment
A5R34	MAX INTEN	Maximum intensity adjustment
A9C5 A9R3	0-90 PHASE ADJ 0-90 GAIN ADJ	Phase detector and A-D converter tracking adjustment
A9R14	5 ADJ	Voltage regulator adjustment
A10C1	OSC LEVEL ADJ	80MHz-IF/2 VCXO level adjust.
A10C20 A10C22 A10C30 A10C32	BPF ADJ BPF ADJ BPF ADJ BPF ADJ	160MHz-IF level adjustment
A10C112	OSC LEVEL ADJ	80MHz VCXO osc. level adjust.
A10C123 A10C125 A10C136 A10C138	BPF ADJ BPF ADJ BPF ADJ BPF ADJ	160MHz output level adjustment

Table 5-2. Adjustable Components (2 of 3)

Adjustable Component	Adjustment Name	Description
A10R25	IF LEVEL ADJ	IF PLL input signal level adjustment
A10R72	REF FREQ ADJ	80MHz VCXO free-run freq. adjust.
A11L5		VCO center frequency adjustment
A11R1		VCO test voltage setting
A11R8	100KHz NULL ADJ	100kHz sample/hold noise rejection
A11R58 A11R76 A11R77	API 3 ADJ API 2 ADJ API 1 ADJ	API current source adjustment
A17R1	SCREEN	CRT voltage adjustment
A20R45		Local feedthrough adjust. for A21 mixer.
A21C7	(CV1)	IF amplifier phase adjustment
A21L1 A21L2 A21L3	IF BPF ADJ	IF band-pass filter adjustment
A21R24	(RV1)	IF amplifier gain adjustment
A21R116	(RV3)	Local feedthrough adjustment for gain-phase measurement signal
A21A1C1	1M Ω 20dB ADJ	20dB attenuator adjustment
A21A1C2	1M Ω C IN ADJ	Input capacitance adjustment
A21A1R30	(RV1)	DC offset adjustment
A21A2C1	1M Ω 20dB ADJ	20dB attenuator adjustment
A21A2C2	1M Ω C IN ADJ	Input capacitance adjustment
A21A2R21	(RV1)	DC offset adjustment
A22C47	NOTCH FILTER ADJ	Pre-amplifier notch filter adjust.
A22R28	FLATNESS ADJ	Pre-amplifier flatness adjustment
A22R37	LOCAL LEVEL ADJ 1	Mixer local level adjustment

Table 5-2. Adjustable Components (3 of 3)

Adjustable Component	Adjustment Name	Description
A22R68	OUTPUT LEVEL ADJ	Test signal output level adjust.
A22R90	LOCAL LEVEL ADJ 2	Mixer local level adjustment
A22R124		Integrator offset adjustment
A22R127		Integrator offset adjustment
A22R139	VA.G	Vector generator gain adjustment
A22R140	VB.G	Vector generator gain adjustment
A22R179	VAO	Vector generator offset adjustment
A22R180	VBO	Vector generator offset adjustment
A23R93	LO FEEDTHRU ADJ	Local signal feedthrough adjustment
A24R2		DC bias gain adjustment
A24R8		DC bias polarity tracking
A24R29	RF/AF TRACK	RF/AF tracking adjustment
A24R38	DISTORTION ADJ	Power amplifier distortion adjust.
A24R104 A24R109	OFFSETS OFFSETS	DC bias offset adjustment
A25R2	F-ADJ	High Stability Osc. freq. adjust.
A25R4	V-ADJ	Ref. oven osc. voltage adjust.
H.V.BLOCK	FOCUS	CRT focus adjustment
H.V.BLOCK	CONV	CRT convergence adjustment
INTENSITY		CRT intensity control

Table 5-3. Factory Selected Components

Component	Nominal Value	Reference
A5R7	12.1k Ω	Refer to Paragraph 5-21-3.
A10L39 and L40	100nH to 330nH 0nH to 470nH	Refer to Paragraph 5-11-2.
A21C9	2.2pf to 2.7pf	Refer to Paragraph 5-18-5.

Table 5-4. Required Adjustments

Assembly Repaired or Replaced	Required Adjustments (paragraph)
A1 Primary Rectifier	None
A2 Power Supply Control	5-8
A3 Power Supply Output	None
A4 CRT Deflection	5-22
A5 Video Amplifier	5-22
A6 Data Manipulation Processor	None
A7 GDC/RAM	None
A8 Measurement Control Processor	5-20 and 5-21
A9 Phase Detector/A-D Converter	5-10, 5-19, and 5-21
A10 Reference Frequency Generator	5-11, 5-12, 5-15, and 5-21
A11 Fractional N Loop	5-13, 5-15, and 5-21
A12 Keyboard Control	None
A13 Control Unit Keyboard	None
A14 Power Supply Motherboard	None
A15 Motherboard	None
A17 CRT Socket	5-22
A20 Range Resistor	5-14, 5-18, 5-21, and 5-21
A21 (A31)* Process Amplifier	5-17, 5-18, and 5-21
A22 Modulator/Frequency Converter	5-14, 5-15, 5-21, and 5-21
A23 Null Detector	5-14, 5-20, and 5-21
A24 (A34)* Output Amplifier	5-15, 5-16, 5-20, and 5-21
A25 High Stability Oscillator	5-9
A26 Measurement Unit Keyboard	None.

* A31 and A34 replace A21 and A24, respectively, in Option 375 units.

5-8. SWITCHING POWER SUPPLY ADJUSTMENTS

This is a two part adjustment. In the first part you will adjust the frequency of the switching power supply, and in the second you will adjust its output voltage. The equipment required is listed below. Figure 5-1 shows the equipment setup.

Frequency Counter	HP 5385A Opt. 004
Digital Voltmeter	HP 3456A
10:1 Divider Probe, 1M Ω	HP 10040A
Dual Banana Plug-to-Alligator Clip Leads	

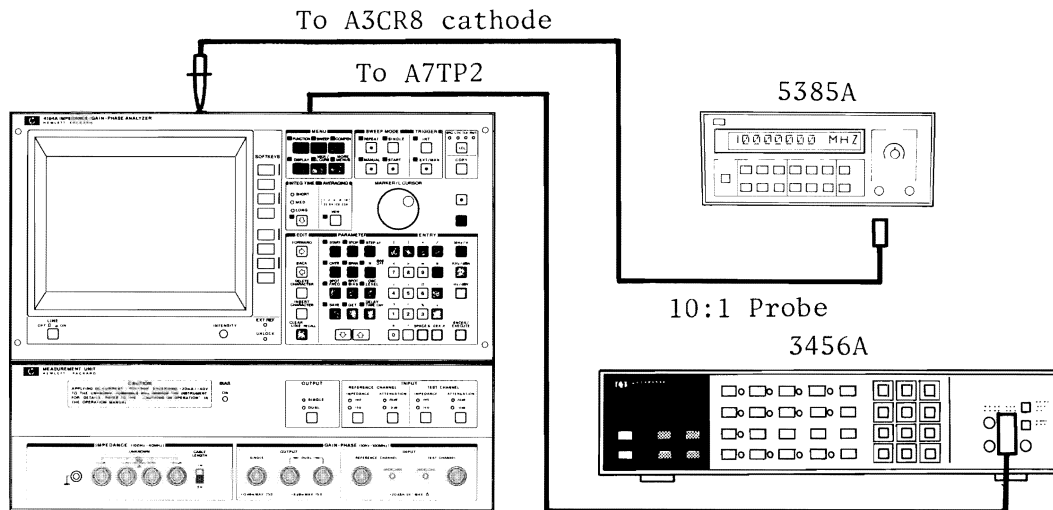

Figure 5-1. Switching Power Supply Adjustment Setup

WARNING

DO NOT GROUND THE SHIELDING OR TEST PIN ON THE A2 BOARD.

PROCEDURE:

Switching Frequency Adjustment

1. Remove the top shield plate from the 4194A's Control Unit.
2. Set the 5385A's controls to measure a 60kHz, 15Vpp signal.
3. Connect the 10040A to the 5385A's INPUT A and probe the cathode of A3CR8. Connect the ground lead to A3TP3.

CAUTION

USE A 10:1 PROBE FOR THIS ADJUSTMENT. FAILURE TO DO SO WILL RESULT IN DAMAGE TO THE 5835A.

ADJUSTMENTS

4. Turn the 4194A on.
5. Adjust A2R8 (FRQ-ADJ) until the frequency reading on the 5385A is **58kHz±2kHz**. Figure 5-2 shows adjustment locations.
6. Turn the 4194A off. Continue on to the next adjustment without changing your test setup.

Output Voltage Adjustment

1. Connect the 3456A's high lead to A7TP2 and the low lead to A7TP1. Figure 5-2 shows the location of test points.
2. Turn the 4194A on.
3. Adjust A2R7 (V-ADJ) until the voltage reading on the 3456A is **5.025V±0.01V**.
4. Connect the low lead to A3TP3.
5. Connect the high lead to each test point listed in **Table 5-5** and confirm that the voltage at each test point is within the **test limits** listed in the **table**.

Note

If any of the voltages listed in Table 5-5 do not satisfy the indicated test limits, clean the edge connectors on the A3 and A7 boards and repeat this adjustment. If cleaning the edge connectors doesn't solve the problem, perform troubleshooting as described in Section 8.

6. Turn the 4194A off.

Table 5-5. Power Supply Voltage Confirmation Check Limits

Test Points	Test Limits
A3TP1	50.0V to 53.5V
A3TP2	-51.0V to -54.0V
A3TP4	15.5V to 17.5V
A3TP5	-15.5V to -17.5V
A3TP6	7.5V to 8.5V
A3TP7	5.1V to 5.35V

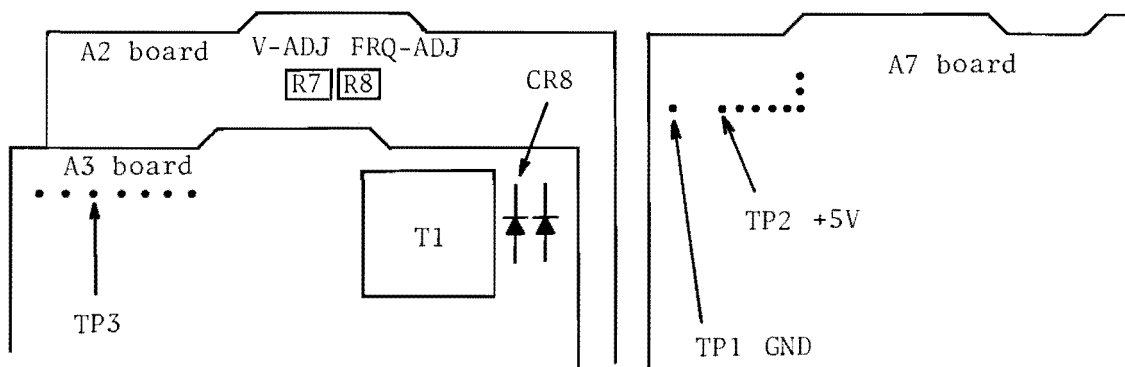

Figure 5-2. Switching Power Supply Adjustment and Test Point Locations

ADJUSTMENTS

5-9. HIGH STABILITY OSCILLATOR ADJUSTMENTS (OPT. 001 ONLY)

This is a two part adjustment. In the first part you will adjust the supply voltage for A25E1, and in the second part you will adjust the frequency of the High Stability Oscillator. The equipment required is listed below. Figure 5-3 shows the equipment setup.

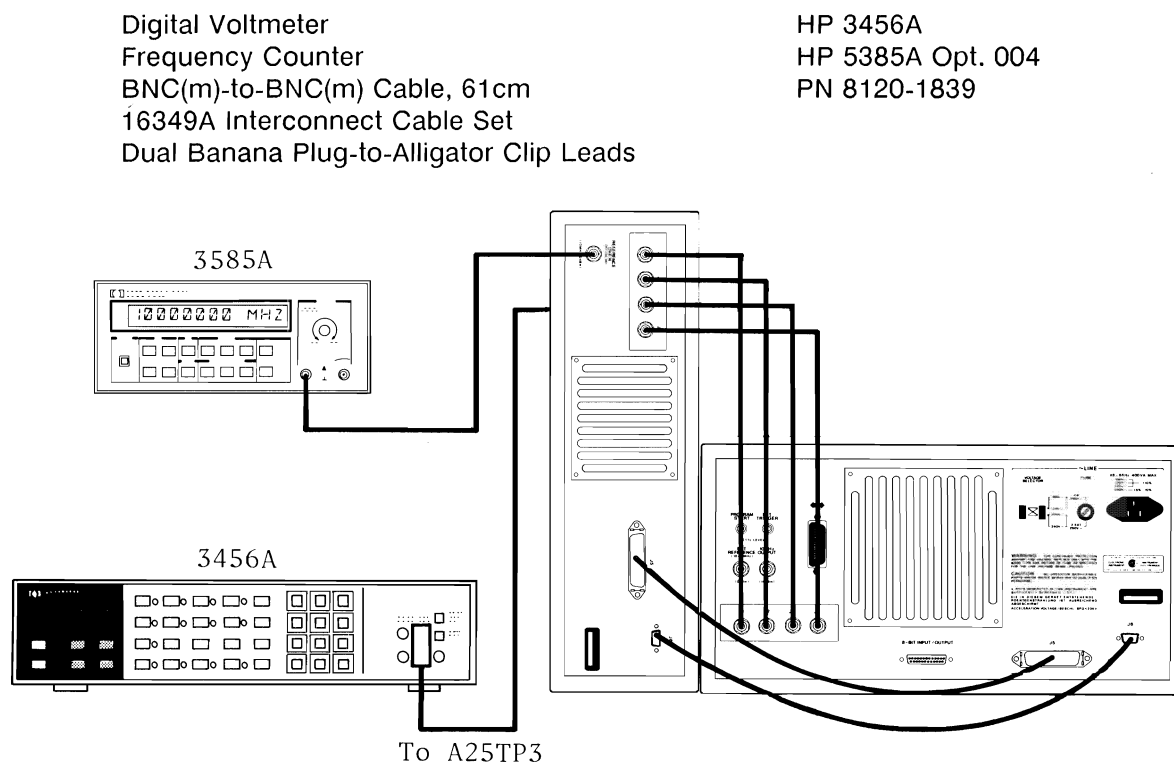

Figure 5-3. High Stability Oscillator Adjustment Setup

PROCEDURE:

A25E1 Supply Voltage Adjustment

1. Unlink the 4194A and place the Control Unit and the Measurement Unit as shown. Interconnect the units using the longer cables included with the 16349A product support package.
2. Connect the 3456A's high lead to A25TP3 and the low lead to A25TP1.
3. Turn the 4194A on.
4. Adjust A25R4 (V-ADJ) until the voltage reading is $15V \pm 15mV$.
5. To stabilize the oven temperature, allow the 4194A to warm up for at least thirty minutes before proceeding to the next adjustment in this procedure.

Note

Because the next adjustment in this procedure will not affect the remaining adjustments, you can continue on to the adjustment in paragraph 5-10 during the oven temperature stabilization period. Don't forget to come back and finish the final steps in this procedure, however.

High Stability Oscillator Frequency Adjustment

1. Connect INPUT A of the 5385A to the REFERENCE OVEN connector on the rear panel of the 4194A's Measurement Unit.
2. Adjust A25R2 (F-ADJ) until the reading on the 5385A is **10MHz±100mHz**.

5-10. LOCAL VOLTAGE REGULATOR ADJUSTMENT

This procedure is for adjusting and confirming local regulator output voltages. The equipment required is listed below. Figure 5-4 shows the equipment setup.

Digital Voltmeter

HP 3456A

Dual Banana Plug-to-Alligator Clip Leads

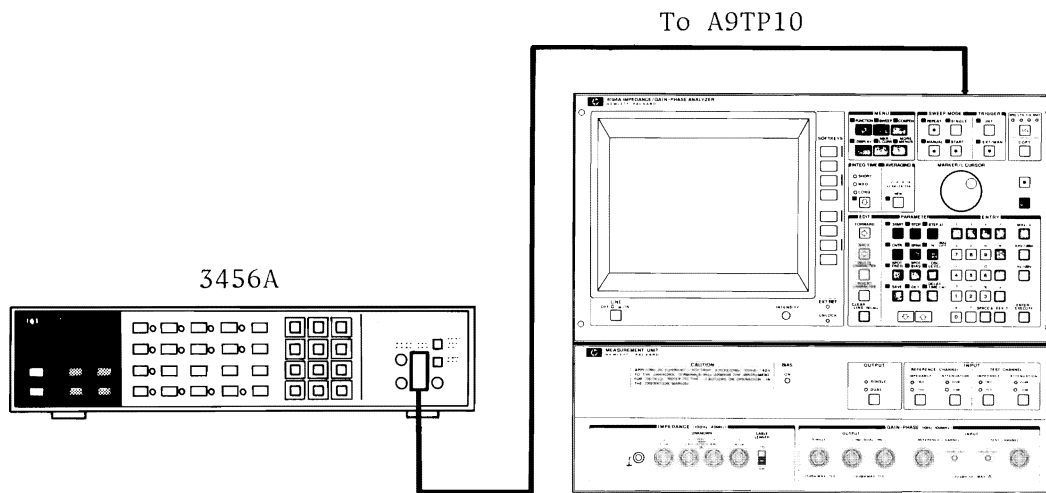

Figure 5-4. Local Voltage Regulator Adjustment Setup

PROCEDURE:

1. Connect the 3456A's high lead to A9TP10 and the low lead to A9TP9 (GND).
2. Adjust A9R14 (5ADJ) until the voltage is $5.05V \pm 20mV$.
3. Connect the high lead to A9TP11 (12) and confirm that the voltage is **11.8V to 12.4V**.
4. Connect the high lead to A9TP12 (-12) and confirm that the voltage is **-11.8V to -12.4V**.

Note

If the voltage measured in step 3 or 4 does not satisfy the indicated limits, repeat step 2. If repeating step 2 does not correct the problem, troubleshoot as described in Section 8.

5-11. 160MHz REFERENCE ADJUSTMENTS

This is a three part adjustment. In the first part you will adjust the level of the signal output from the 80MHz VCXO, and in the second part you will adjust its output frequency. In the third part you will adjust the level of the 160MHz reference signal.

5-11-1. 80MHz VCXO Level Adjustment

PURPOSE:

To adjust the level of the signal output from the 80MHz VCXO. Figure 5-5 shows the setup for this adjustment.

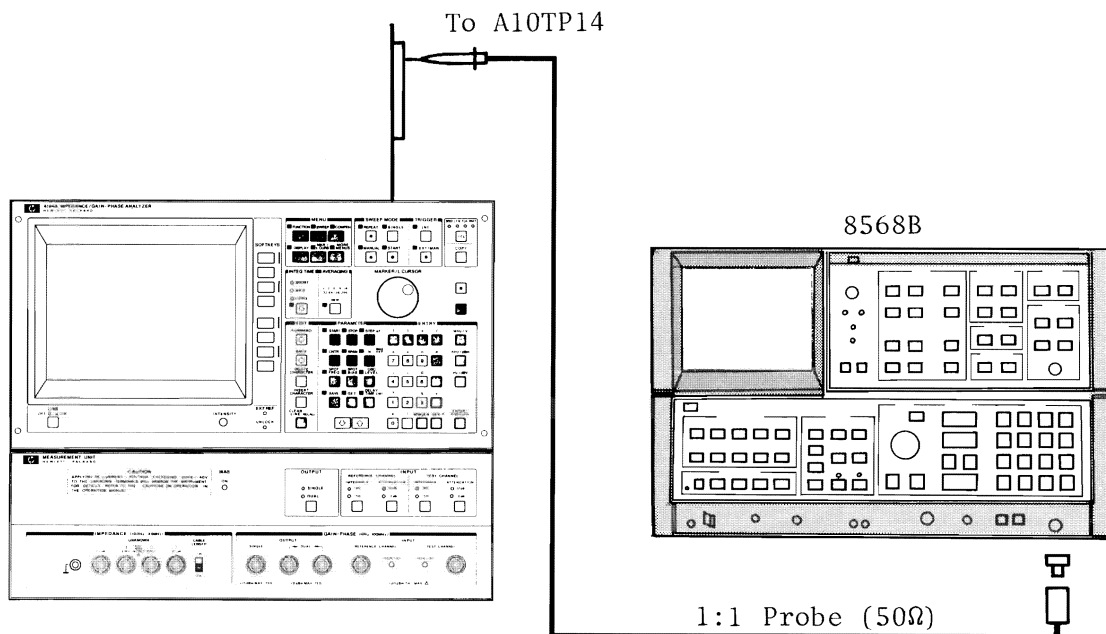

Figure 5-5. 80MHz VCXO Level Adjustment Setup

EQUIPMENT:

Spectrum Analyzer
1:1 Probe, 50Ω
N(m)-to-BNC(f) Adapter
Extender Board

HP 8568B
HP 10026A
PN 1250-0780
PN 16349-66504

PROCEDURE:

1. Extend the A10 board.

Note

If the 4194A is equipped with option 001, disconnect the cable from the EXT REFERENCE terminal on the rear panel of the Control Unit.

2. Connect the probe to INPUT #2 of the 8568B and probe A10TP14 (OSC LEVEL).

Note

Be sure to use a 1:1 probe with a characteristic impedance of 50Ω.

3. Set the 8568B as follows:

CENTER FREQUENCY	80MHz
FREQUENCY SPAN	500kHz
RES BW	3kHz
REFERENCE LEVEL	0dBm

4. Adjust A10C112 (OSC LEVEL ADJ) so that the signal level is within the range of **-30dBm** to **-33dBm** and the frequency is as close as possible to **80MHz**.

5-11-2. 80MHz VCXO Frequency Adjustment

PURPOSE:

To adjust the frequency of the 80MHz VCXO when there is no external reference signal applied. Figure 5-6 shows the setup for this adjustment.

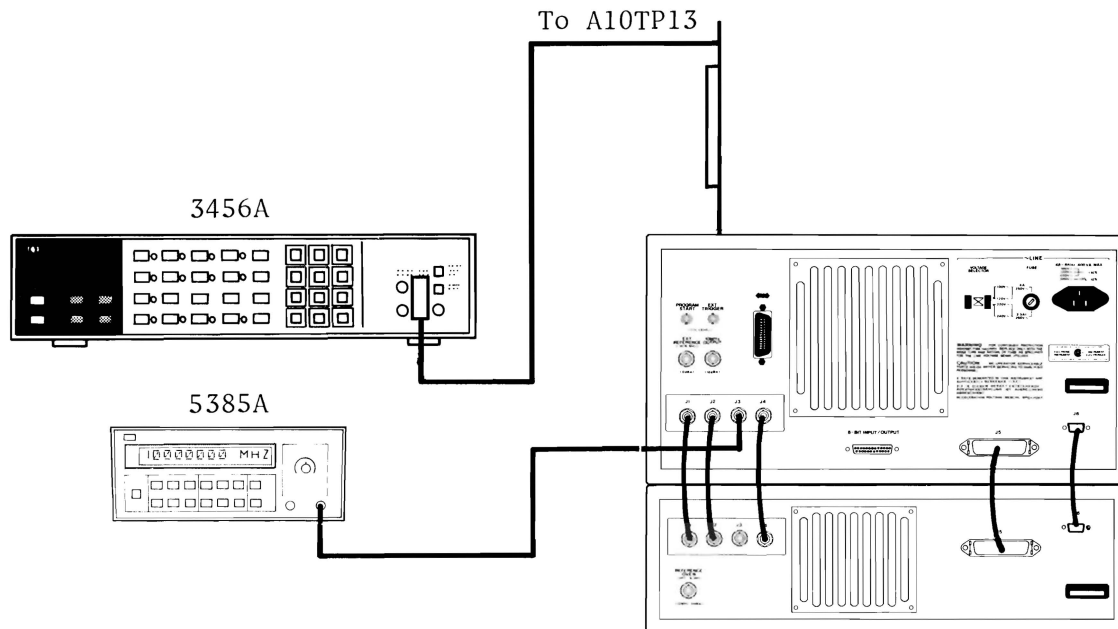

Figure 5-6. 80MHz VCXO Frequency Adjustment Setup

EQUIPMENT:

Frequency Counter	HP 5385A Opt. 004
Digital Voltmeter	HP 3456A
BNC(m)-to-BNC(m) Cable, 61cm	PN 8120-1839
Extender Board	PN 16349-66504
Dual Banana Plug-to-Alligator Clip Leads	

PROCEDURE:

1. Disconnect the BNC cable from the J3 (160MHz) connector on the rear panel of the Control Unit.
2. Connect the 5385A's INPUT B to J3.
3. Adjust A10R72 (REF FREQ ADJ) until the frequency is **160MHz ±0.001MHz**.
4. Check the dc voltage at A10TP13 (REF TUNE). This voltage should be between **0.5V** and **3.5V**. If the dc voltage is not within these limits, change A10L39 and L40 in accordance with Table 5-6 and repeat this step.

Table 5-6. L39 and L40 Selection

DC Voltage at TP13	A10L39	A10L40
4.3V to 6.3V	PN 9100-2247: 100nH	PN 8159-0005: Jumper
3.5V to 4.3V	PN 9100-2247: 100nH	PN 9100-2247: 100nH
0.5V to 3.5V	PN 9100-2247: 100nH	PN 9100-2251: 220nH
-1.3V to 0.5V	PN 9100-2247: 100nH	PN 9100-0368: 330nH
-2.4V to -1.3V	PN 9100-2249: 150nH	PN 9100-0368: 330nH
-4.2V to -2.4V	PN 9100-0368: 330nH	PN 9100-2251: 220nH
-6.0V to -4.2V	PN 9100-2249: 150nH	PN 9100-2255: 470nH

5-11-3. 160MHz Reference Signal Level Adjustment

PURPOSE:

To adjust the level of the 160MHz signal used in the Measurement Unit. Figure 5-7 shows the setup for this adjustment.

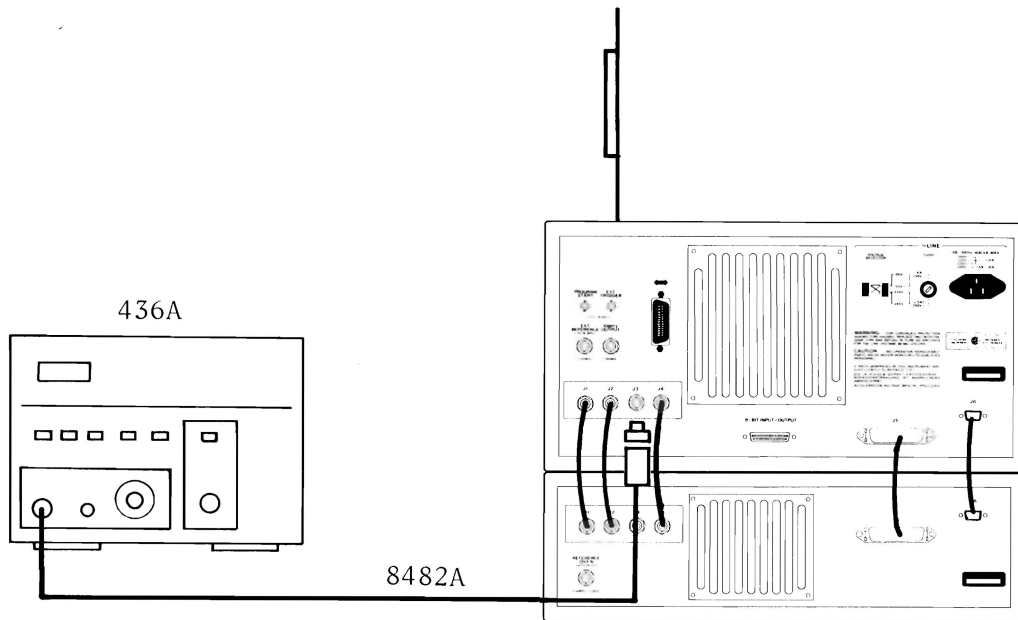

Figure 5-7. 160MHz Signal Output Level Adjustment Setup

EQUIPMENT:

Power Meter	HP 436A
Power Sensor	HP 8482A
N(f)-to-BNC(m) Adapter	PN 1250-0077
Extender Board	PN 16349-66504

1. Connect the 8482A and the 436A to the J3 (160MHz) connector on the rear panel of the Control Unit.
2. Adjust A10C123, C125, C136 and C138 (BPF ADJ) for the maximum power reading on the 436A.
3. Adjust A10C136 so that the power reading is $-5\text{dBm} \pm 0.5\text{dBm}$.
4. Reconnect the BNC cable from the Measurement Unit's rear panel J3 connector to the J3 connector on the Control Unit's rear panel.

5-12. 160MHz-IF REFERENCE ADJUSTMENTS

This is a three part adjustment similar to the adjustment described in paragraph 5-11. In the first part you will adjust the variable frequency range of the signal output from the 80MHz-IF/2 VCXO, and in the second part you will adjust the level of the 160MHz-IF reference signal. Finally, in the third part you will adjust the level of the IF signal used in the phase-locked loop. The equipment required is listed below.

5-12-1. 80MHz-IF/2 VCXO Level and Variable Range Adjustment

PURPOSE:

To adjust the 80MHz-IF/2 VCXO signal level and variable frequency range. Figure 5-8 shows the setup for this adjustment.

Note

If the 80MHz-IF/2 VCXO is not phase locked with the 80MHz VCXO, perform the IF Level Adjustment in paragraph 5-12-3 before proceeding with this adjustment.

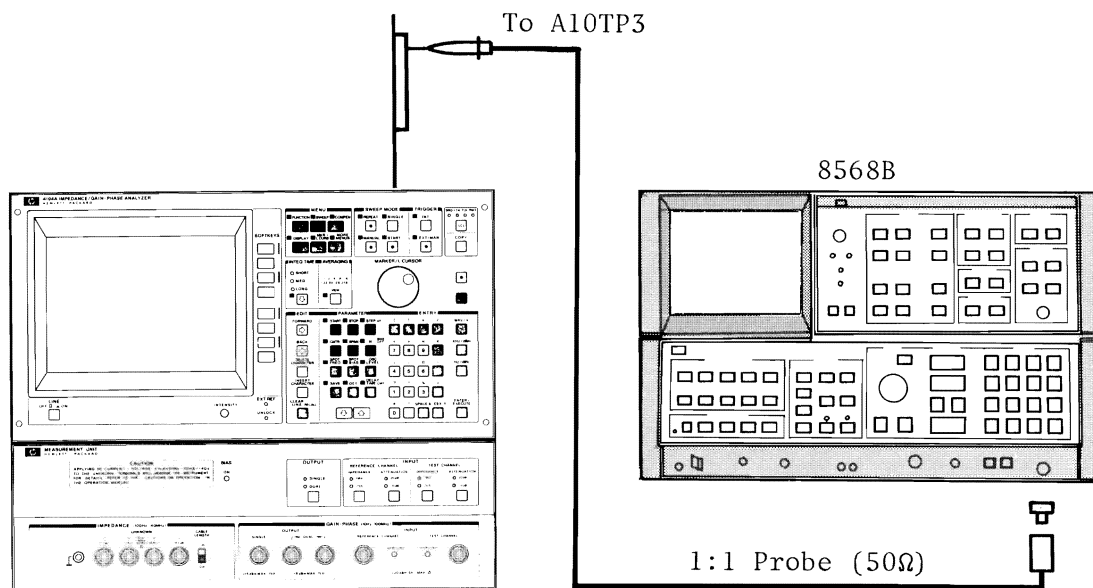

Figure 5-8. 80MHz-IF/2 VCXO Level and Variable Range Adjustment Setup

EQUIPMENT:

Spectrum Analyzer
 1:1 Probe, 50Ω
 N(m)-to-BNC(f) Adapter
 Extender Board

HP 8568B
 HP 10026A
 PN 1250-0780
 PN 16349-66504

PROCEDURE:

1. Set jumper A10W3 to the TEST position.
2. Using the 1:1 probe, connect the 8568B's INPUT #2 to A10TP3 OSC LEVEL (160MHz-IF).

Note

Characteristic impedance of the 1:1 probe must be 50Ω.

3. Set the 8568B as follows:

CENTER FREQUENCY	79.9306MHz
FREQUENCY SPAN	500kHz
RES BW	3kHz
REFERENCE LEVEL	0dBm
FREQ COUNT	on

4. Adjust A10C1 (OSC LEVEL ADJ) to set the frequency for each A10W3--A10W5--A10J1 setting combination listed in Table 5-7.

Table 5-7. 80MHz-IF/2 VCXO Variable Range Adjustment

A10W3	A10W5	A10J1	Frequency
TEST	NORMAL	Disconnect	< 79.9278MHz
Disconnect	NORMAL	Disconnect	< 79.9191MHz
Disconnect	Disconnect	Connect	> 79.9247MHz
TEST	Disconnect	Connect	> 79.9334MHz

5. Restore A10W5 to the NORMAL position and reconnect the cable to A10J1. Leave A10W3 in the TEST position.

5-12-2. 160MHz-IF Signal Level Adjustment

PURPOSE:

To adjust the level of the 160MHz-IF signal. Figure 5-9 shows the setup.

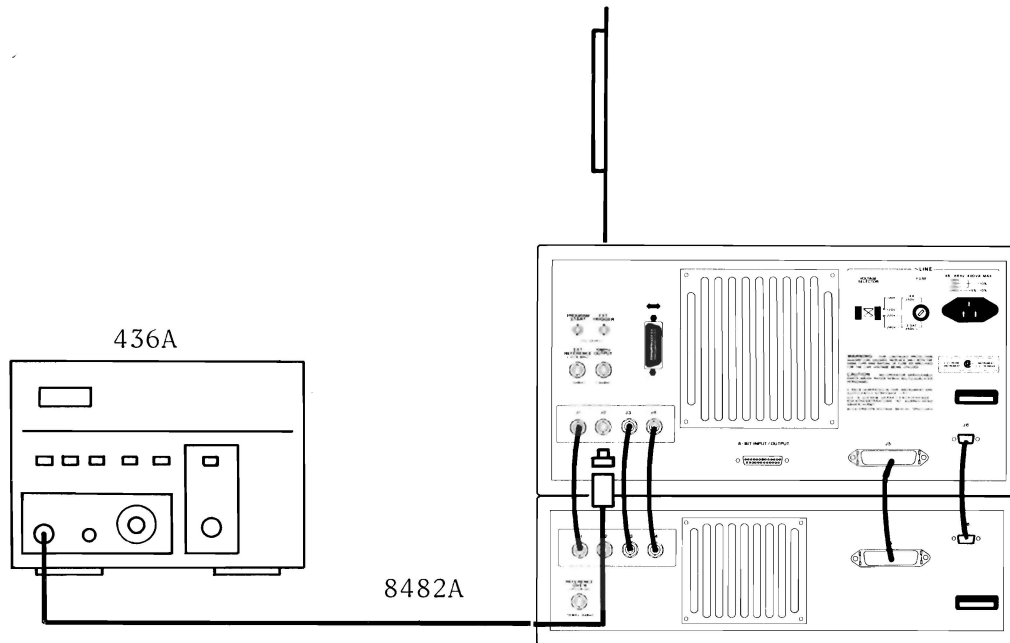

Figure 5-9. 160MHz-IF Signal Level Adjustment Setup

EQUIPMENT:

Power Meter	HP 436A
Power Sensor	HP 8482A
N(f)-to-BNC(m) Adapter	PN 1250-0077
Extender Board	PN 16349-66504

PROCEDURE:

1. Confirm that A10W3 is set to the TEST position, then disconnect the BNC cable from the J2 (160MHz-IF) connector on the rear panel of the Control Unit and connect the 8482A and 436A to J2.
2. Adjust A10C20, C22, C30, and C32 (BPF ADJ) for the maximum power reading on the 436A Power Meter.
3. Adjust A10C30 for a power reading of $-7\text{dBm} \pm 0.5\text{dBm}$, then reconnect J2.

5-12-3. IF Level Adjustment

PURPOSE:

To adjust the IF signal level of the PLL circuit to maintain a phase lock between the 80MHz-IF/2 VCXO and the 80MHz VCXO. Figure 5-10 shows the setup for this adjustment.

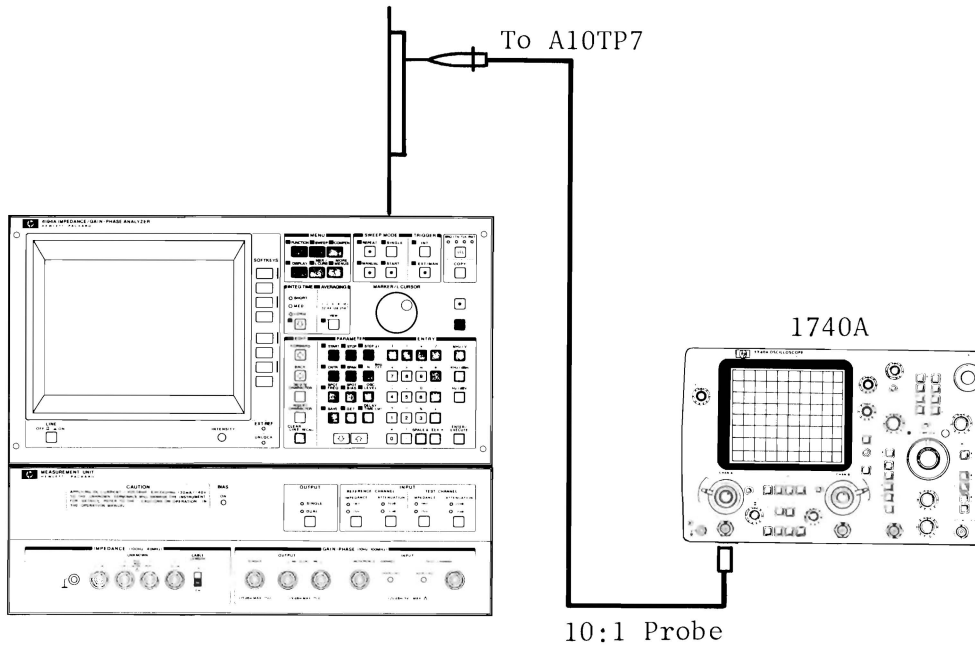

Figure 5-10. IF Level Adjustment Setup

EQUIPMENT:

Oscilloscope
 10:1 Divider Probe, 1MΩ
 Extender Board

HP 1740A
 HP 10040A
 PN 16349-66504

PROCEDURE:

1. Confirm that A10W3 is in the TEST position, then connect the 1740A to A10TP7 (IF OUT) using the 10040A probe and adjust A10R25 (IF LEVEL ADJ) so that the displayed waveform on the 1740A is **4Vpp±1V**.
2. Check that the negative region of the waveform does not exceed **-0.7V**. If it does, check diode A10CR20, then reset A10W3 to the NORMAL position.

5-13. FRACTIONAL N PLL ADJUSTMENTS

This three part procedure adjusts the center frequency of the VCO, minimizes the 100kHz sample/hold spurious, and correctly sets the API current sources.

5-13-1. VCO Center Frequency Adjustment

PURPOSE:

To adjust the center frequency of the VCO. Figure 5-11 shows the setup for this adjustment.

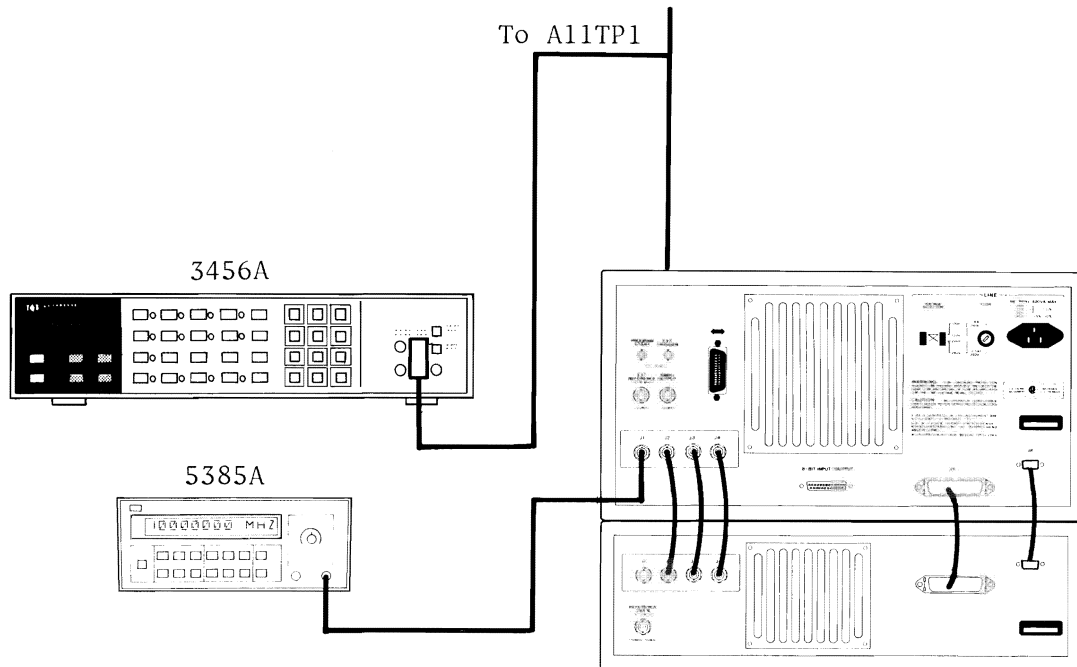

Figure 5-11. VCO Center Frequency Adjustment Setup

EQUIPMENT:

Digital Voltmeter	HP 3456A
Frequency Counter	HP 5385A Opt. 004
BNC(m)-to-BNC(m) Cable, 61cm	PN 8120-1839
Extender Board	PN 16349-66504
Dual Banana Plug-to-Alligator Clip Leads	

PROCEDURE:

1. Extend the A11 board.
2. Disconnect the BNC cable from J1 (VCO) on the rear panel of the 4194A's Control Unit.
3. Connect the 5385A's INPUT B to J1.
4. Set jumper A11W1 to the TEST position.
5. Connect the 3456A's high lead to A11TP1.
6. Set the 4194A's TRIGGER Mode to **EXT/MAN**.
7. Adjust A11R1 until the dc voltage at A11TP1 is $0V \pm 0.2V$. Figure 5-12 shows the adjustment locations.
8. Adjust A11L5 until the VCO frequency is $225MHz \pm 2MHz$.
9. Reset jumper A11W1 to the NORMAL position.

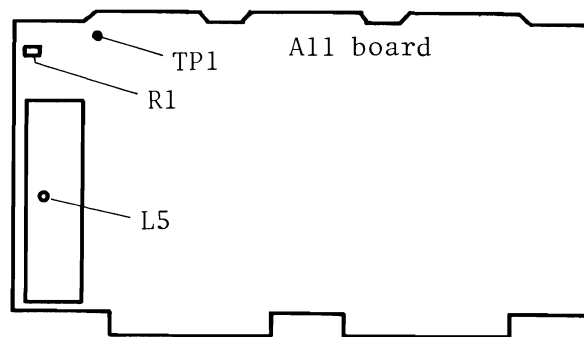

Figure 5-12. VCO Center Frequency Adjustment Locations

5-13-2. VCO 100kHz Spurious Rejection Adjustment

PURPOSE:

To minimize the 100kHz spurious signal from the VCO output. Figure 5-13 shows the setup for this adjustment and for the succeeding adjustment.

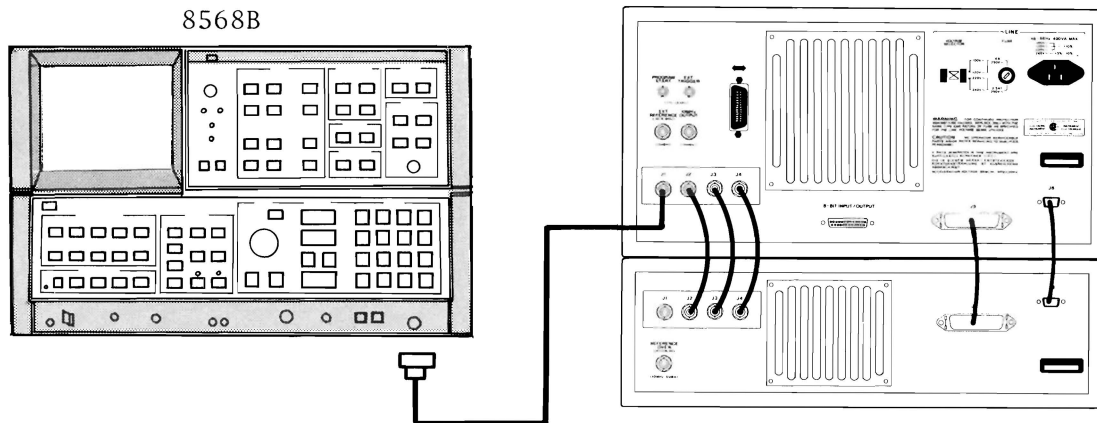

Figure 5-13. VCO 100kHz Spurious Rejection and API Adjustment Setup

EQUIPMENT:

Spectrum Analyzer	HP 8568B
BNC(m)-to-BNC(m) Cable, 61cm	PN 8120-1839
N(m)-to-BNC(f) Adapter	PN 1250-0780

PROCEDURE:

1. Reinstall the A11 board and replace the top shield plate.
2. Connect the 8568B's INPUT #2 to J1 (VCO) on the rear panel of the 4194A's Control Unit.

3. Set the 8568B's controls as follows.

CENTER FREQUENCY	164MHz
FREQUENCY SPAN	1MHz
RES BW	3kHz
REFERENCE LEVEL	2.2dBm

4. Set the 4194A's controls as follows.

FUNCTION	GAIN/PHASE
CENTER FREQUENCY	4MHz
FREQUENCY SPAN	0Hz

ADJUSTMENTS

- Adjust A11R8 (100kHz NULL ADJ) until the peak of the 100kHz spurious signal is minimized and is at least **80dB** below the fundamental. Figure 5-14 shows a signal that is out of adjustment and Figure 5-15 shows a properly adjusted signal.

Note

Continue on to the next adjustment without dismantling the present setup.

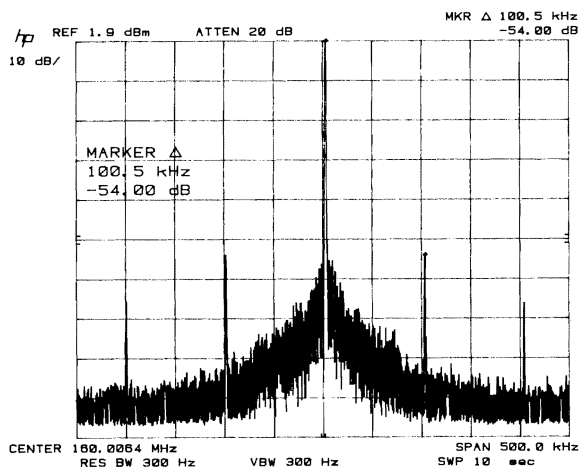

Figure 5-14. Incorrectly Adjusted VCO Output

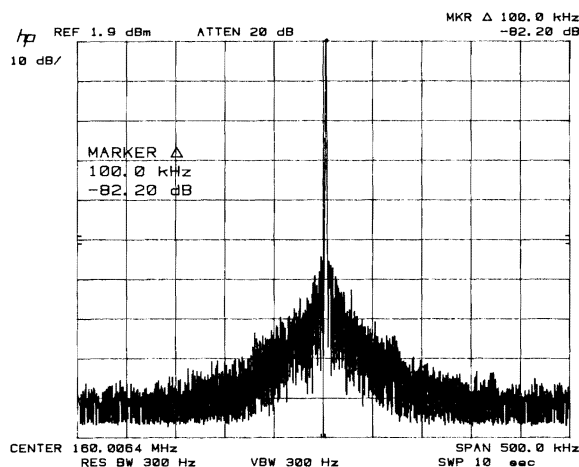

Figure 5-15. Properly Adjusted VCO Output

5-13-3. API Adjustment

PURPOSE:

To adjust the API current sources. Figure 5-13 shows the setup for this adjustment.

PROCEDURE:

- Allow the 4194A to warm up for an additional 30 minutes.
- Set the 8568B as follows:

CENTER FREQUENCY	160.006MHz
FREQUENCY SPAN	60kHz
REFERENCE LEVEL	10dBm
RES BW	300Hz

- Set the 4194A as follows:

CENTER FREQUENCY	6kHz
FREQUENCY SPAN	0Hz

5. Adjust A11R77 (API 1 ADJ) until the **159.994MHz** and **160.018MHz** spurious signals are at least **54dB** below the fundamental, and all remaining signals in the spectrum are at least **45dB** below the fundamental. Figure 5-16 shows an API 1 spectrum that's out of adjustment; Figure 5-19 shows what a properly adjusted spectrum looks like.
6. Adjust A11R76 (API 2 ADJ) until the **159.991MHz** and **160.021MHz** spurious signals are minimized and are at least **45dB** below the fundamental. Figure 5-17 shows an API 2 spectrum that's out of adjustment; Figure 5-19 shows what a properly adjusted spectrum looks like.
7. Change the 4194A's CENTER FREQUENCY to **6.33kHz**.
8. Adjust A11R58 (API 3 ADJ) until the **159.9887MHz** and **160.021MHz** spurious signals are minimized and are at least **45dB** below the fundamental. Figure 5-18 shows an API 3 spectrum that's out of adjustment; Figure 5-19 shows what a properly adjusted spectrum looks like.
9. Turn the 4194A off and reconnect the BNC cable to J1.

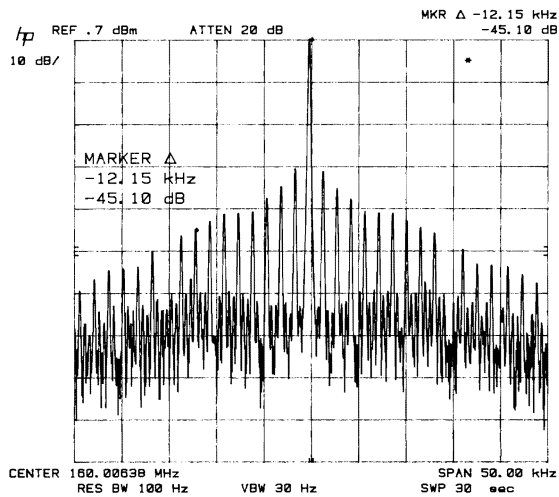

Figure 5-16. Incorrectly Adjusted API 1 Spectrum

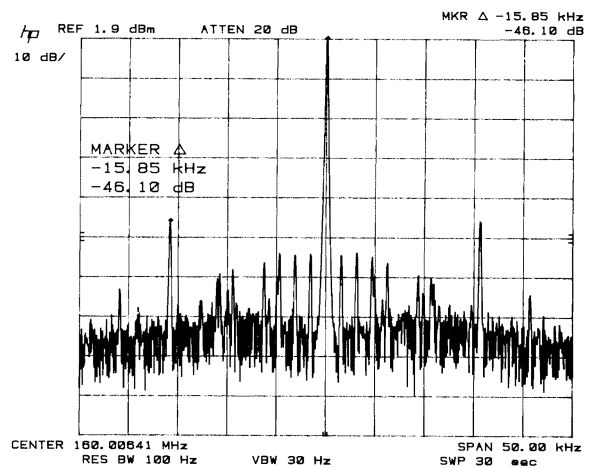

Figure 5-17. Incorrectly Adjusted API 2 Spectrum

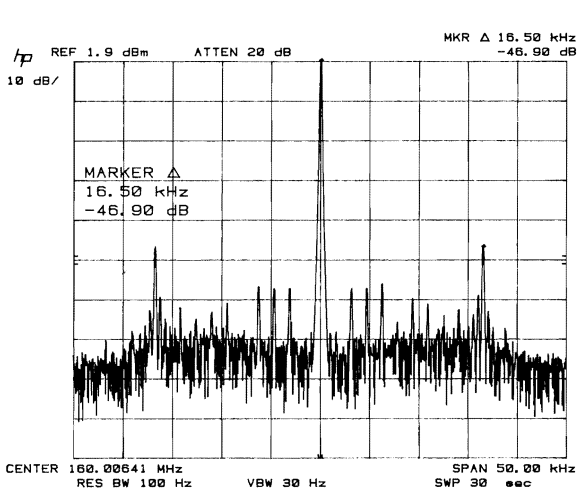

Figure 5-18. Incorrectly Adjustment API 3 Spectrum

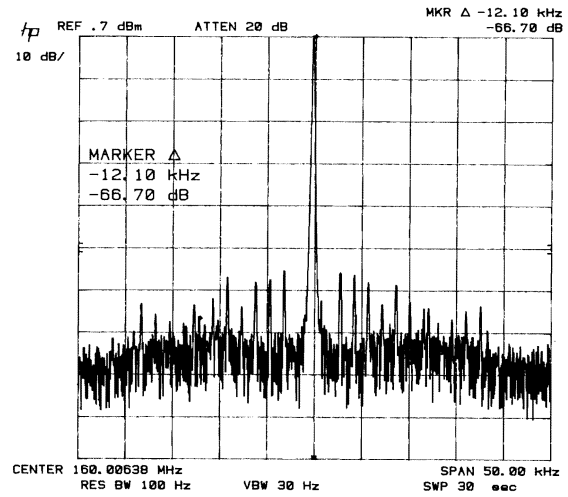

Figure 5-19. Properly Adjusted Spectrum

5-14. BRIDGE ADJUSTMENTS

This three part procedure minimizes feedthrough from the local oscillator in the null detector mixer, adjusts the L_{cur} output gain, and adjusts the offset of the integrator.

5-14-1. A23 Local Oscillator Feedthrough Adjustment

PURPOSE:

To minimize the feedthrough from the local oscillator in the null detector's mixer. Figure 5-20 shows the setup for this adjustment.

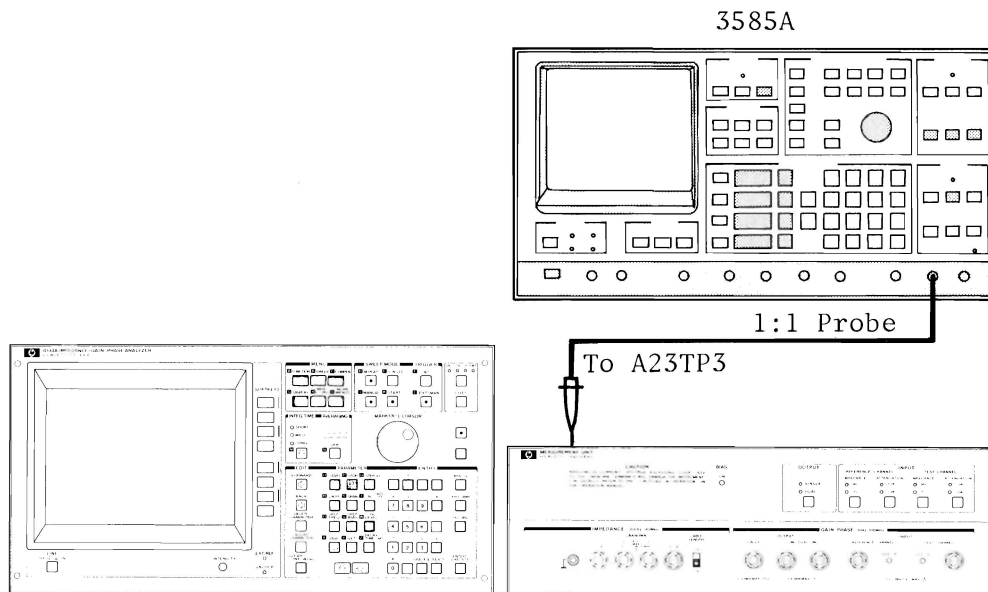

Figure 5-20. A23 Local Oscillator Adjustment Setup

EQUIPMENT:

Spectrum Analyzer	HP 3585A
1:1 Probe, 1M Ω	HP 10021A
16349A Interconnect Cable Set	

PROCEDURE:

1. Disconnect the cables that interconnect the 4194A's Measurement Unit and Control Unit. Position these two units as shown in Figure 5-20. Interconnect the units using the longer cables furnished in the 16349A Product Support Package.
2. Make sure that nothing is connected to the **UNKNOWN** terminals.

3. Connect the 3585A's 1M Ω input to A23TP3.
4. Set the 3585A's controls as follows:

RANGE	10dBm
CENTER FREQUENCY	157.25kHz
FREQUENCY SPAN	10kHz
REFERENCE LEVEL	10dBm
5. Start SELF TEST #52.
6. Set the SPOT FREQ to **1kHz**.
7. Select the **400 Ω** range resistor by pressing the '**Z RNG**' softkey, and the **2** and **ENTER/EXECUTE** keys.
8. Adjust A23R93 until the **157.25kHz** spurious signal is minimized and is at least **-26dBm**. Figure 5-21 shows the adjustment locations.
9. Press the '**TEST END**' softkey.

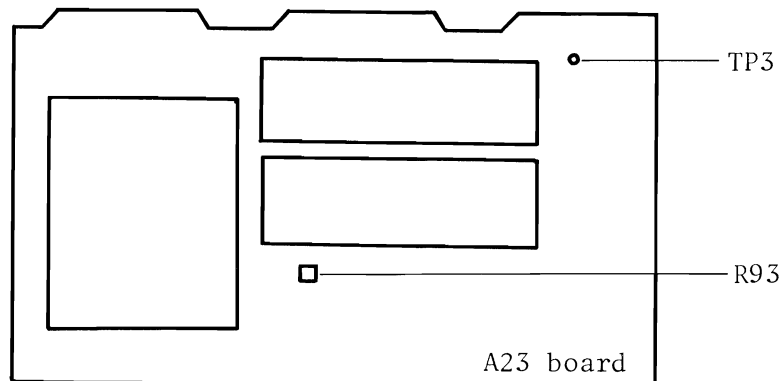

Figure 5-21. A23 Local Oscillator Adjustment Locations

5-14-2. L_{CUR} Output Adjustments**PURPOSE:**

To adjust the gain and offset of the L_{CUR} circuit. Figure 5-22 shows the setup for these adjustments.

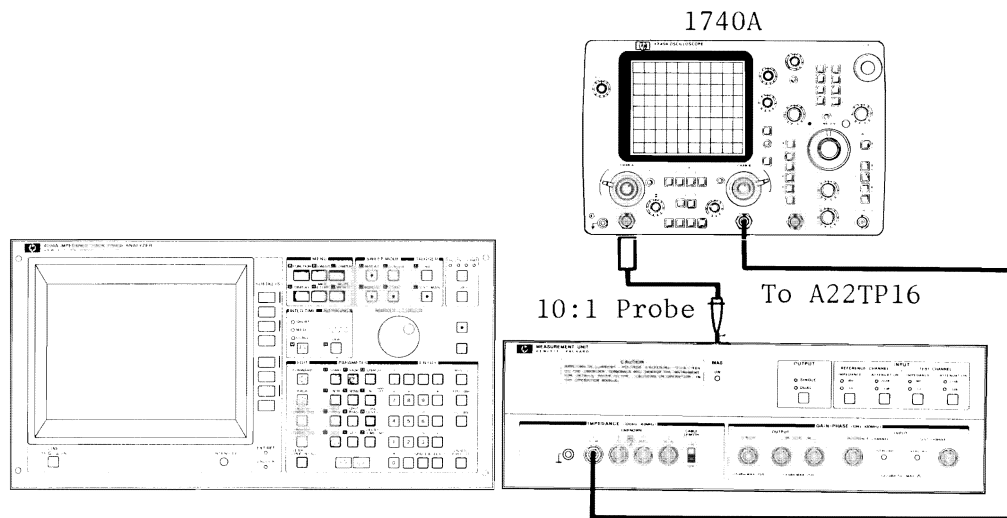

Figure 5-22. L_{CUR} Output Adjustments Setup

EQUIPMENT:

Oscilloscope	HP 1740A
10:1 Divider Probe, 1M Ω	HP 10040A
BNC(m)-to-BNC(m) Cable, 61cm	PN 8120-1839
16349A Interconnect Cable Set	

PROCEDURE:

- Set the 1740A as follows:

CHAN A INPUT	1M Ω DC, 0.01V/DIV
CHAN B INPUT	1M Ω DC, 0.2V/DIV
TIME BASE	50 μ sec/DIV
- Set number 7 of A8SW1 to the right-most position. This will allow you to manually select range resistors.
- Set A22W1 and W2 to the TEST position.
- Disconnect the coaxial cable from A22J5.

5. Connect the 1740A's CHAN A INPUT to A22TP16.
6. Connect the 1740A's CHAN B INPUT to the **UNKNOWN** L_{CUR} terminal.
7. Set the 4194A's controls as follows:

FUNCTION	IMPEDANCE
FREQUENCY SPAN	0Hz
CENTER FREQUENCY	20kHz
8. Press the **CLEAR LINE**, **Blue**, **R**, **Z**, **1**, and **ENTER/EXECUTE** keys.
9. Adjust A22R127 until the dc voltage at A22TP16 is **0V±30mV**. Figure 5-23 shows adjustment locations.
10. Connect the 1740A's CHAN A INPUT to A22TP15.
11. Adjust A22R124 until the dc voltage at A22TP15 is **0V±30mV**.
12. Adjust A22R179 and A22R180 until the voltage at the L_{CUR} terminal is no more than **40mVpp**.
13. Adjust A22R124 until the dc voltage at A22TP15 is **100mV±10mV**. If you cannot set the voltage to **100mV**, adjust A22R124 to **-100mV±10mV**.
14. Adjust A22R140 until the voltage at the L_{CUR} terminal is **0.8Vpp ±0.1V**.
15. Readjust A22R124 until the dc voltage at A22TP15 is **0V±30mV**.
16. Connect the 1740A's CHAN A INPUT to A22TP16.
17. Adjust A22R127 until the dc voltage at A22TP16 is **100mV±10mV**. If you cannot set the voltage to **100mV**, adjust A22R127 to **-100mV±10mV**.
18. Adjust A22R139 until the voltage at the L_{CUR} terminal is **0.8Vpp ±0.1V**.
19. Readjust A22R127 until the dc voltage at A22TP16 is **0V±30mV**.
20. Measure the voltage at the L_{CUR} terminal. If this voltage exceeds **40mVpp**, repeat this procedure from step 12.
21. Reset A8SW1, number 7, to the left-most (OFF) position.
22. Reset A22W1 and W2 to the NORMAL position.
23. Reconnect the coaxial cable to A22J5.

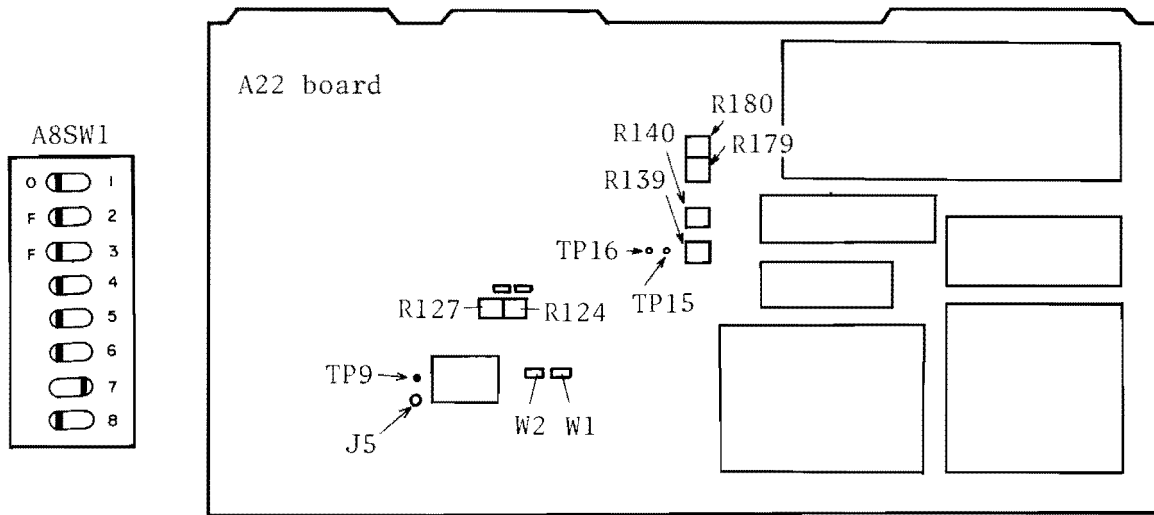

Figure 5-23. Lcur Output Adjustment Locations

5-14-3. Integrator Offset Fine Adjustment

PURPOSE:

To minimize the dc offsets of the integrators. Figure 5-24 shows the setup.

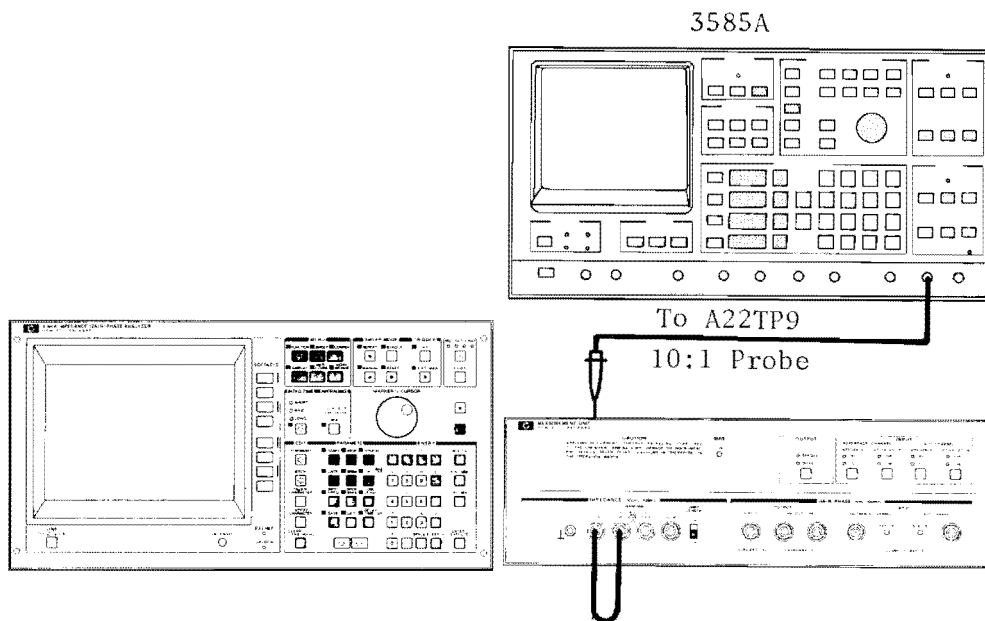

Figure 5-24. Integrator Offset Fine Adjustment Setup

EQUIPMENT:

Spectrum Analyzer	HP 3585A
10:1 Divider Probe, 1M Ω	HP 10040A
BNC(m)-to-BNC(m) Cable, 30cm	PN 8120-1838
16349A Interconnection Cable Set	

PROCEDURE:

1. Set the 3585A as follows:

CENTER FREQUENCY	156.25kHz
FREQUENCY SPAN	10kHz
INPUT RANGE	0dBm
REFERENCE LEVEL	0dBm

2. Interconnect the L_{CUR} and L_{POT} terminals using a BNC-to-BNC cable.
3. Connect the 3585A's 1M Ω INPUT to A22TP9.
4. Set the 4194A as follows:

FREQUENCY SPAN	0Hz
CENTER FREQUENCY	1MHz

5. Adjust A22R124 and R127 so that the **156.25kHz** signal at A22TP9 is at least **-90dBm**.

5-15. FREQUENCY CONVERTER/TEST SIGNAL AMPLIFIER ADJUSTMENTS

This six part procedure adjusts (1) the pre-amplifier's notch filter frequency, (2) the input signals to the mixers, (3) the test signal's output level, (4) the power amplifier's distortion, (5) the flatness of the pre-amplifier's output, and (6) RF/AF Gain Tracking.

5-15-1. 160MHz Notch Filter Adjustment

PURPOSE:

To adjust the frequency of the pre-amplifier's notch filter to reject the local signal frequency. Figure 5-25 shows the setup for this adjustment.

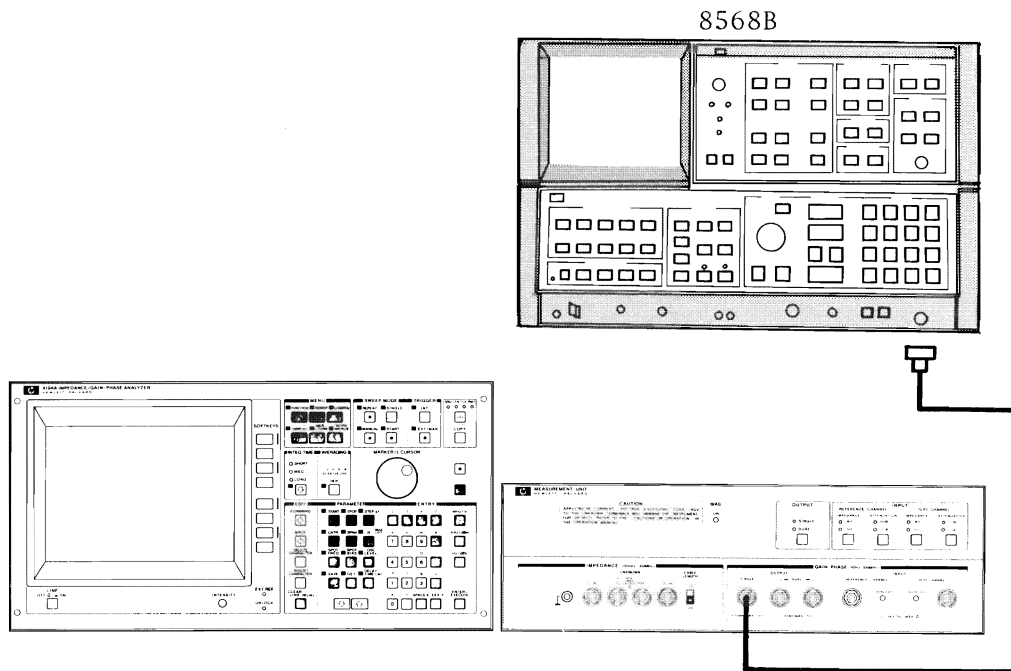

Figure 5-25. 160MHz Notch Filter Adjustment Setup

EQUIPMENT:

Spectrum Analyzer
 BNC(m)-to-BNC(m) Cable, 61cm
 N(m)-to-BNC(f) Adapter
 16349A Interconnection Cable Set

HP 8568B
 PN 8120-1839
 PN 1250-0780

PROCEDURE:

1. Disconnect the BNC cables from J2 (160MHz-IF) and J3 (160MHz) on the Measurement Unit's rear panel.

ADJUSTMENTS

2. Connect the 8568B's INPUT #2 to the 4194A's SINGLE OUTPUT connector.
3. Set the 8568B as follows:

CENTER FREQUENCY	160MHz
FREQUENCY SPAN	10MHz
REFERENCE LEVEL	-10dBm
4. Set the 4194A as follows:

FUNCTION	GAIN-PHASE
SWEEP MODE	MANUAL
MANUAL FREQUENCY	10Hz
OSC LEVEL	15dBm
OUTPUT	SINGLE
5. Adjust A22C47 until the **160MHz** signal is minimized.
6. Reconnect the BNC cables to J2 and J3.

5-15-2. Mixer Local Level Adjustment

PURPOSE:

To adjust the input signal levels of the mixers to **minimize** unwanted output frequencies. Figure 5-26 shows the setup for this adjustment.

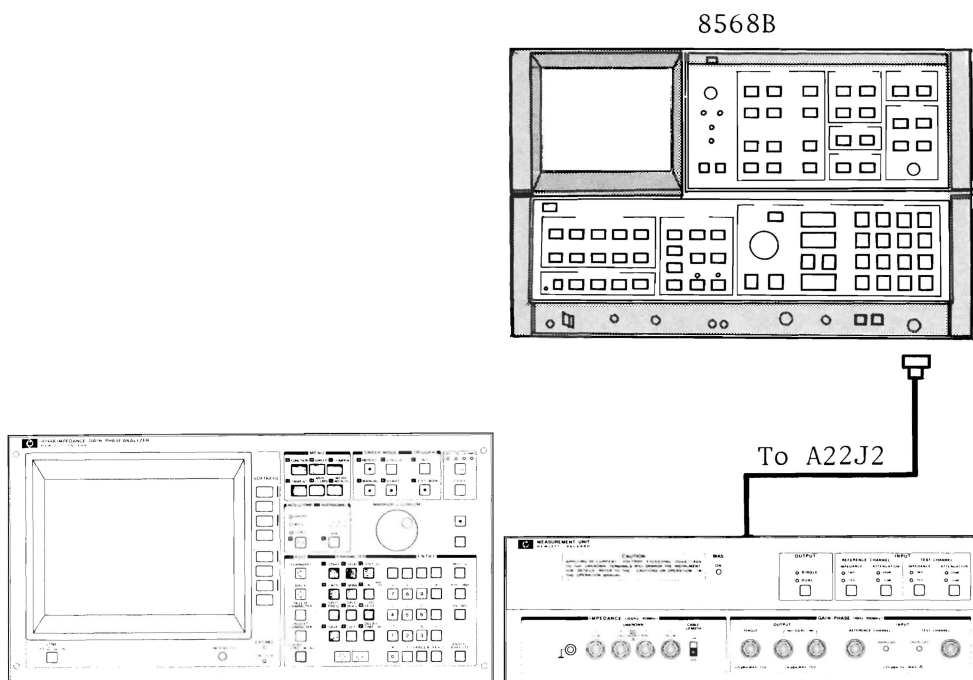

Figure 5-26. Mixer Local Level Adjustment Setup

EQUIPMENT:

Spectrum Analyzer	HP 8568B
SMB(f)-to-BNC(m) Cable	PN 04280-65002
N(m)-to-BNC(f) Adapter	PN 1250-0780
16349A Interconnect Cable Set	

PROCEDURE:

Test Signal Mixer Local Level Adjustment

1. Disconnect the cable from A22J2.
2. Connect the 8568B's INPUT #2 to A22J2.
3. Set the 8568B as follows:

START FREQ	50MHz
STOP FREQ	110MHz
REFERENCE LEVEL	approx. -5dBm

4. Set the 4194A as follows:

FUNCTION	GAIN-PHASE
SWEEP MODE	MANUAL
START FREQUENCY	60MHz
STOP FREQUENCY	100MHz
STEP FREQUENCY	10MHz
OSC LEVEL	15dBm
MANUAL FREQUENCY	60MHz

5. Adjust A22R37 so that the 100MHz frequency component is at least **53dB** below the level of the test frequency. Repeat this adjustment for each test frequency listed in Table 5-8.

Note

When the frequency component being adjusted reaches -53dB, be sure that further adjustment does not decrease the test frequency level by more than 1dB.

Table 5-8. Test Signal Mixer Local Level Adjustment Frequencies

Test Freq.	Freq. Component
70MHz	90MHz
90MHz	70MHz
100MHz	60MHz

6. Reconnect the coaxial cable to A22J2.

Local Frequency Mixer Local Level Adjustment

1. Disconnect the cable from A22J8 and connect the 8568B's INPUT #2 to A22J8.
2. Change the 8568B's REFERENCE LEVEL to approx. **-14dBm**
3. Set the 4194A's test frequency to 60MHz.
4. Adjust A22R90 so that the 100MHz frequency component is at least **53dB** below the level of the test frequency. Repeat this adjustment for each frequency listed in Table 5-9.

Note

When the frequency component being adjusted reaches -53dB, be sure that further adjustment does not decrease the test frequency level by more than 1dB.

Table 5-9. Local Frequency Mixer Local Level Adjustment Frequencies

Test Freq.	Freq. Component
70MHz	90MHz
90MHz	70MHz
100MHz	60MHz

5. Reconnect the coaxial cable to A22J8.

5-15-3. Test Signal Level Adjustment

PURPOSE:

To accurately adjust the test signal level. Figure 5-27 shows the setup.

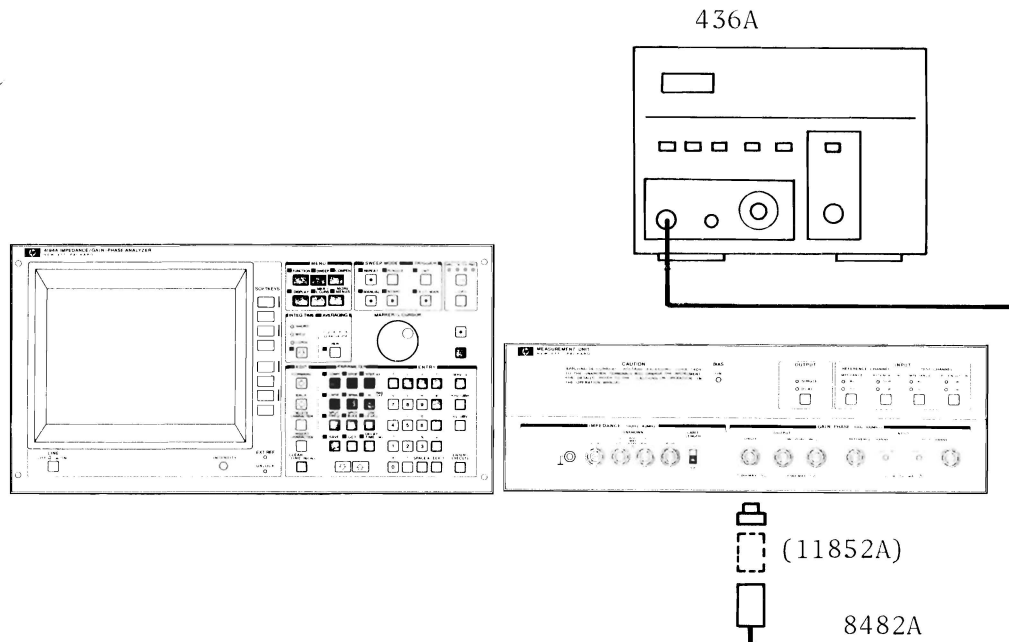

Figure 5-27. Test Signal Level and Flatness Adjustment Setup

EQUIPMENT:

Power Meter	HP 436A
Power Sensor	HP 8482A
N(f)-to-BNC(m) Adapter	PN 1250-0077
50Ω - 75Ω Minimum Loss Pad*	HP 11852A
N(f)-to-BNC(m) Adapter, 75Ω*	PN 1250-1534
16349A Interconnect Cable Set	

* Required for Option 375 instruments only.

PROCEDURE:

1. Connect the 8482A and the 436A to the 4194A's SINGLE OUTPUT connector. For a 75Ω 4194A (Option 375), insert the HP 11852A between the SINGLE OUTPUT connector and the 8482A as shown in Figure 5-27.
2. Start SELF TEST #71, then adjust A22R68 (OUTPUT LEVEL ADJ) for a power reading of **15.0dBm ±0.1dB** for Option 350 4194As, or **9.3dB±0.1dB** for Option 375 4194As.

5-15-4. Power Amplifier Distortion Adjustment

PURPOSE:

To adjust the collector voltage and current of the final power transistor so as to minimize distortion. Figure 5-28 shows the setup.

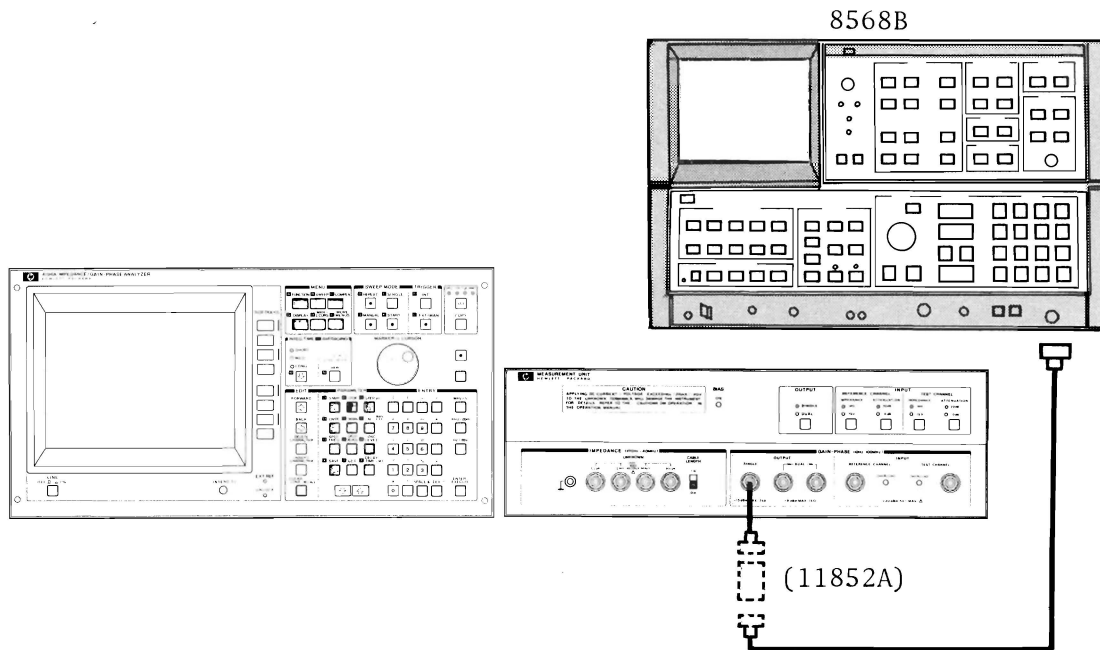

Figure 5-28. Power Amplifier Distortion Adjustment Setup

EQUIPMENT:

Spectrum Analyzer	HP 8568B
BNC(m)-to-BNC(m) Cable, 61cm	HP 8120-1839
N(m)-to-BNC(f) Adapter	PN 1250-0780
50 Ω - 75 Ω Minimum Loss Pad*	HP 11852A
N(f)-to-BNC(m) Adapter, 75 Ω *	PN 1250-1534
N(m)-to-BNC(f) Adapter, 50 Ω *	PN 1250-0780
HP 16349A'S Interconnect Cable Set	

* Required for Option 375 instruments only.

PROCEDURE:

1. Connect the 8568B's INPUT #2 to the 4194A's SINGLE OUTPUT. If you're adjusting a 75 Ω 4194A (Option 375), insert the HP 11852A between the SINGLE OUTPUT connector and the 8482A as shown in Figure 5-28.

- Set the 8568B as follows:

START FREQ	10MHz
STOP FREQ	320MHz
REFERENCE LEVEL	15dBm (Option 350)
	9.3dBm (Option 375)

- Set the 4194A as follows:

FUNCTION	GAIN-PHASE
SWEEP MODE	MANUAL
START FREQUENCY	10MHz
STOP FREQUENCY	100MHz
NUMBER OF SWEEP POINTS	101
OSC LEVEL	15dBm
OUTPUT	SINGLE

- Adjust A24R38 until all spurious signals are at least **33dB** below the fundamental.
- Manually sweep the 4194A's test frequency range and check that the spurious signals at each frequency are at least **33dB** below the fundamental. If any signals do not meet this criteria, repeat this procedure from step 4.

5-15-5. Pre-amplifier Output Flatness Adjustment

PURPOSE:

To adjust the flatness of the pre-amplifier's output. Figure 5-27 in paragraph 5-15-3 shows the setup for this adjustment.

EQUIPMENT:

Power Meter	HP 436A
Power Sensor	HP 8482A
N(f)-to-BNC(m) Adapter	PN 1250-0077
50Ω - 75Ω Minimum Loss Pad*	HP 11852A
N(f)-to-BNC(m) Adapter, 75Ω*	PN 1250-1534
HP 16349A's Interconnect Cable Set	

* Required for Option 375 instruments only.

PROCEDURE:

- Connect the 8482A and 436A to the 4194A's SINGLE OUTPUT connector. If you're adjusting a 75Ω 4194A (Option 375), insert the HP 11852A between the SINGLE OUTPUT connector and the 8482A as shown in Figure 5-27.

2. Set the 4194A as follows:

FUNCTION	GAIN-PHASE
FREQUENCY SPAN	0Hz
CENTER FREQUENCY	100MHz
OSC LEVEL	15dBm
OUTPUT	SINGLE

3. Adjust A22R28 (FLATNESS) until the power reading on the 436A is **14.7dBm±0.1dBm** for Option 350 4194As, or **9.0dB±0.1dB** for Option 375 4194As.

5-15-6. RF/AF Gain Tracking Adjustment

PURPOSE:

To adjust the gain of the AF amplifier to track the gain of the RF amplifier. Figure 5-29 shows the setup for this adjustment.

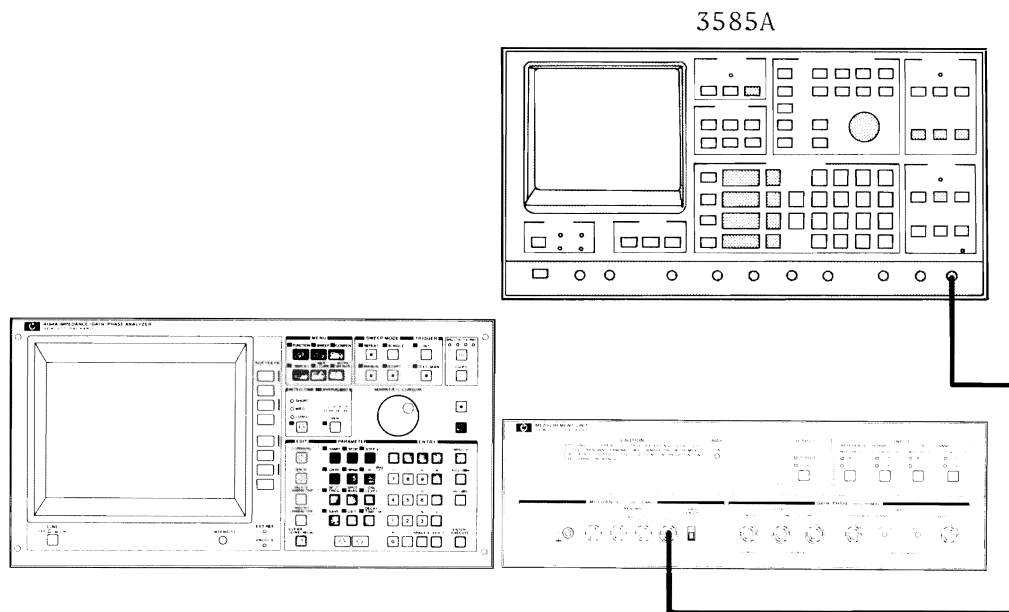

Figure 5-29. RF/AF Gain Tracking Adjustment Setup

EQUIPMENT:

Spectrum Analyzer	HP 3585A
BNC(m)-to-BNC(m) Cable, 61cm,	PN 8120-1839
BNC(m)-to-BNC(m) Cable, 61cm, 75Ω*	PN 04194-61641
HP 16349A Interconnect Cable Set	

* Required for Option 375 instruments only.

PROCEDURE:

1. Connect the 3585A's 50 Ω input to the UNKNOWN Hcur terminal. If you're adjusting a 75 Ω 4194A (Option 375), change the 3585A's input impedance to 75 Ω .

2. Set the 3585A as follows:

FREQUENCY SPAN	0Hz
CENTER FREQUENCY	100kHz
RES BW	10Hz
dB/DIV	1dB/Div

3. Set the 4194A as follows.

FUNCTION	IMPEDANCE
FREQUENCY SPAN	0Hz
CENTER FREQUENCY	100kHz
OSC LEVEL	0dBV

4. Note the signal level at **100kHz** as Pref.
5. Change the 4194A's and 3585A's CENTER FREQUENCY to **3kHz**.
6. Adjust A24R29 (RF/AF TRACK) so that the signal level at **3kHz** is **(Pref+0.4dB), ± 0.1 dB**.

5-16. DC BIAS ADJUSTMENTS

This three part procedure is for adjusting (1) the offset, (2) gain, and (3) polarity tracking of the dc bias source. Figure 5-30 shows the setup for these adjustments.

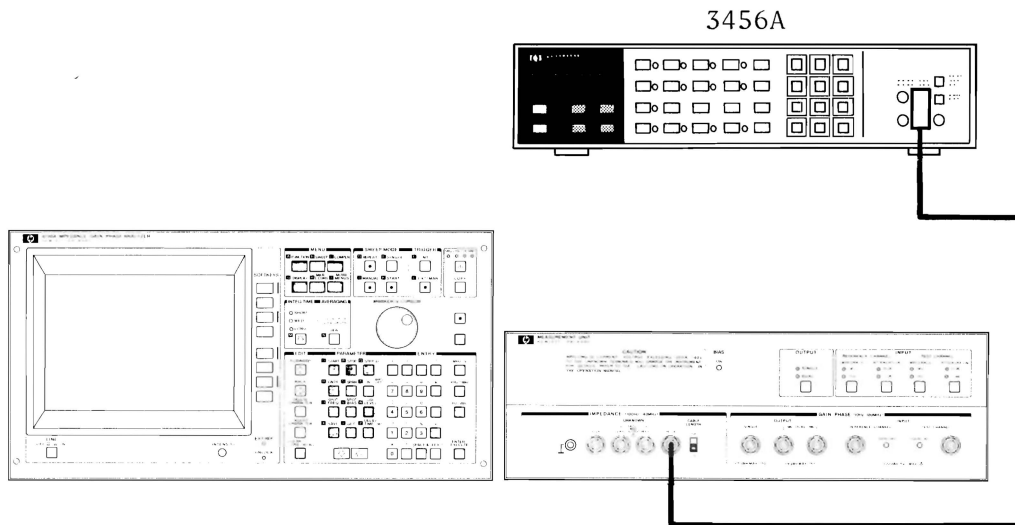

Figure 5-30. DC Bias Adjustment Setup

EQUIPMENT:

Digital Voltmeter
 BNC(m)-to-Dual Banana Plug Cable
 16349A Interconnect Cable Set

HP 3456A
 HP 11035A

PROCEDURE:

DC Bias Offset Adjustment

1. Disconnect the coaxial cable from A24J2.
2. Connect the 3456A's INPUTS to the 4194A's UNKNOWN HCUR terminal.
3. Adjust A24R104 until the dc voltage is $0V \pm 3mV$.
4. Set the 4194A's SPOT BIAS to $0V$. The BIAS ON lamp will light.
5. Adjust A24R109 until the dc voltage is $0V \pm 3mV$.

DC Bias Gain Adjustment

1. Set the 4194A's SPOT BIAS to **40V**.
2. Adjust A24R2 until the dc voltage is **40V \pm 10mV**.

DC Bias Polarity Tracking Adjustment

1. Set the 4194A's SPOT BIAS to **-40V**.
2. Adjust A24R8 until the dc voltage is **-40V \pm 10mV**.
3. Turn the dc bias off.
4. Reconnect the cable to A24J2.

5-17. GAIN-PHASE INPUT AMPLIFIER ADJUSTMENTS

This three part procedure is for adjusting the gain-phase input amplifier's (1) dc offsets, (2) input capacitance, and (3) internal attenuator. The equipment required is listed below.

5-17-1. Input Amplifier DC Offset Adjustment

PURPOSE:

To minimize the dc offsets of the input amplifiers. Figure 5-31 shows the setup for these adjustments.

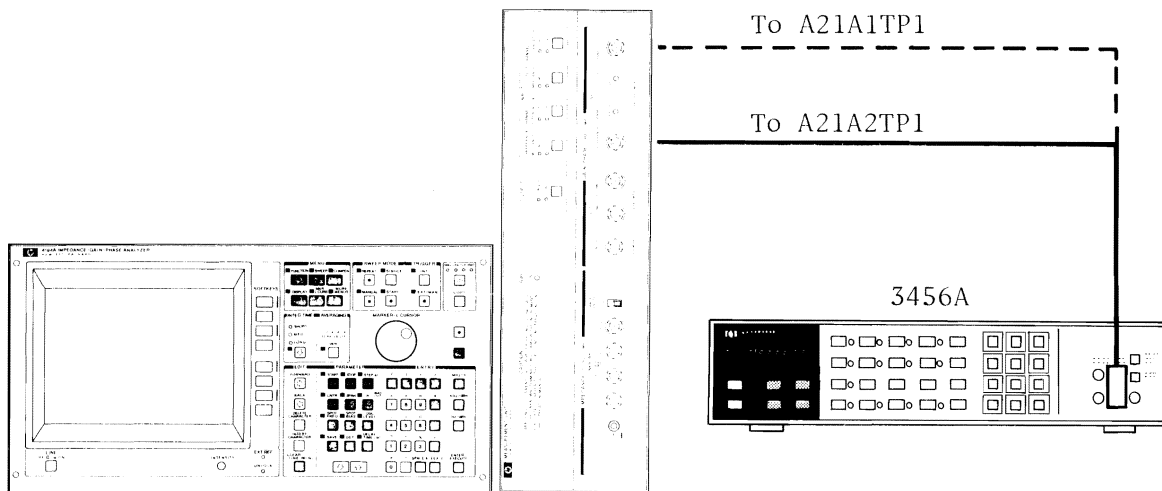

Figure 5-31. Input Amplifier DC Offset Adjustment Setup

EQUIPMENT:

Digital Voltmeter
16349A Interconnect Cable Set
Dual Banana Plug-to-Alligator Clip Leads

HP 3456A

PROCEDURE:

REFERENCE CHANNEL Input Amplifier DC Offset Adjustment

1. Position the 4194A's Measurement Unit as shown in Figure 5-31.
2. Connect nothing to the 4194A's REFERENCE and TEST CHANNEL INPUT terminals.
3. Connect the 3456A's high lead to A21A2TP1.

4. Set the 4194A as follows:

FUNCTION	GAIN-PHASE
FREQUENCY SPAN	0Hz
CENTER FREQUENCY	1MHz
TRIGGER	EXT/MAN

5. Adjust A21A2R21 until the voltage reading is $0V \pm 0.1mV$.

TEST CHANNEL Input Amplifier DC Offset Adjustment

1. Connect the 3456A's high lead to A21A1TP1.
2. Adjust A21A1R30 until the voltage reading is $0V \pm 0.1mV$.

5-17-2. Input Capacitance Adjustment

PURPOSE:

To minimize the $1M\Omega$ input capacitance differences between the **0dB** and **20dB** settings. Figure 5-32 shows the setup for these adjustments.

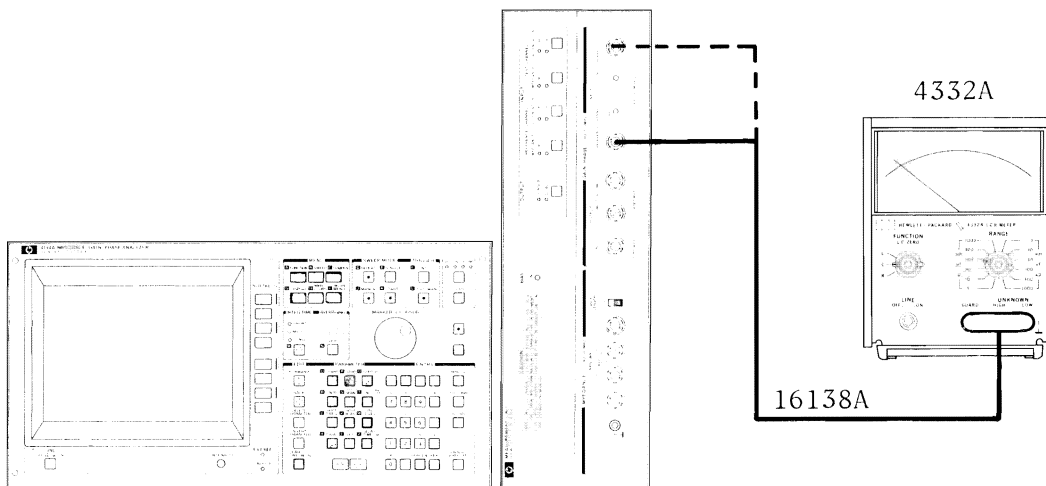

Figure 5-32. Input Capacitance Adjustment Setup

EQUIPMENT:

Capacitance Meter	HP 4332A
Test Leads	HP 16138A
16349A Interconnect Cable Set	

PROCEDURE:

REFERENCE CHANNEL Input Capacitance Adjustment

1. Set the 4332A as follows:

FUNCTION	C
RANGE	30pF

2. Connect the 16138A to the 4332A and ZERO the 4332A.
3. Set the 4194A as follows:

FUNCTION	GAIN/PHASE
OSC LEVEL	-65dBm (minimum)
REFERENCE CHANNEL INPUT IMPEDANCE	1M Ω
REFERENCE CHANNEL INPUT ATTENUATION	0dB

4. Connect the 4332A to the 4194A's REFERENCE CHANNEL INPUT terminal. Use the 16138A Test Leads.
5. Note this capacitance as **C0**. If this capacitance is not between 26pF and 30pF, troubleshoot the A21A2 board and return to this procedure.
6. Change the 4194A's REFERENCE CHANNEL INPUT ATTENUATION to **20dB**.
7. Adjust A21A2C2 until the 4332A's capacitance reading is **C0 \pm 0.2pF**.

TEST CHANNEL Input Capacitance Adjustment

1. Set the 4194A as follows:

TEST CHANNEL INPUT IMPEDANCE	1M Ω
TEST CHANNEL INPUT ATTENUATION	0dB

2. Connect the 4332A to the 4194A's TEST CHANNEL INPUT terminal. Use the 16138A Test Leads.
3. Note this capacitance as **C1**. If this capacitance is not between 26pF and 30pF, troubleshoot the A21A1 board and return to this procedure.
4. Change the 4194A's TEST CHANNEL INPUT ATTENUATION to **20dB**.
5. Adjust A21A1C2 until the 4332A's capacitance reading is **C1 \pm 0.2pF**.

5-17-3. Internal Attenuator Adjustment

PURPOSE:

To adjust the attenuation of the internal $1\text{M}\Omega$ 20dB attenuators. Figure 5-33 shows the setup for these adjustments.

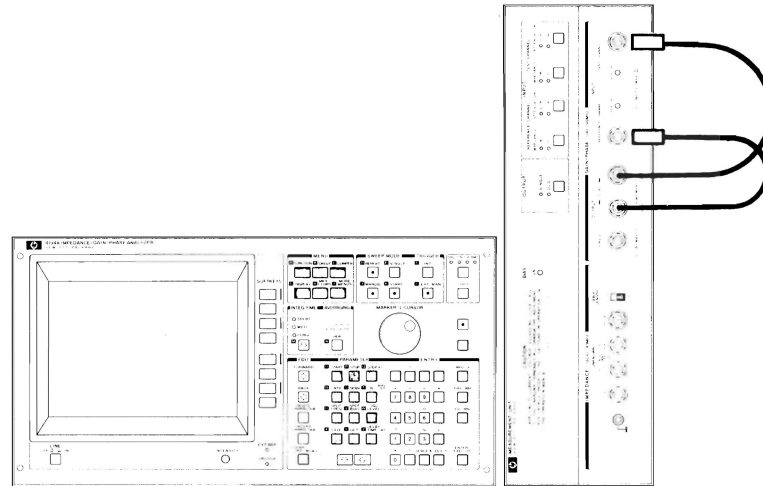

Figure 5-33. Internal Attenuator Adjustment Setup

EQUIPMENT:

BNC(m)-to-BNC(m) Cable, 30cm	PN 1820-1838, 2 each
BNC(m)-to-BNC(m) Cable, 30cm*	PN 04194-61640, 2 each
Feedthrough Termination, 50Ω	PN 04192-61002, 2 each
Feedthrough Termination, 75Ω *	PN 04192-61003, 2 each
16349A Interconnect Cable Set	

* Required for Option 375 instruments only.

PROCEDURE:

1. Connect a feedthrough termination to each of the Measurement Unit's INPUT terminals and interconnect the 4194A's DUAL OUTPUT and INPUT terminals as shown in Figure 5-33.

ADJUSTMENTS

- Set the 4194A as follows:

FUNCTION	GAIN/PHASE
SWEEP	LOG SWEEP
START FREQUENCY	100kHz
STOP FREQUENCY	20MHz
OSC LEVEL	-7dBm
REFERENCE CHANNEL INPUT IMPEDANCE	1M Ω
REFERENCE CHANNEL INPUT ATTENUATION	0dB
TEST CHANNEL INPUT IMPEDANCE	1M Ω
TEST CHANNEL INPUT ATTENUATION	0dB

- Allow at least one sweep to complete.
- Press the **COMPEN** key, then press the '**OFST REF STORE**' and '**A OFFSET on/off**' softkeys.
- Press the **DISPLAY** key and the '**menu**' softkey.
- Set **AMAX** to **1dB** and **AMIN** to **-1dB**.
- Change the REFERENCE CHANNEL INPUT ATTENUATION to **20dB**.
- Adjust A21A2C1 until the yellow trace is **0dB \pm 0.2dB** (1 division on the screen).
- Reset the REFERENCE CHANNEL INPUT ATTENUATION to **0dB** and change the TEST CHANNEL INPUT ATTENUATION to **20dB**.
- Adjust A21A1C1 until the yellow trace is **0dB \pm 0.2dB** (1 division on the screen).

1M Ω 20dB ATTENUATION Confirmation Check

- Set the START FREQUENCY to **10Hz** and the STOP FREQUENCY to **3MHz**.
- Reset the REFERENCE and TEST CHANNEL INPUT ATTENUATION to **0dB**.
- Allow at least one sweep to complete.
- Press the **COMPEN** key.
- Press the '**OFST REF STORE**', '**A OFFSET on/off**', and '**B OFFSET on/off**' softkeys to turn on the offset compensation mode.
- Change the REFERENCE CHANNEL ATTENUATION to **20dB**.
- Confirm that the yellow trace is **0dB \pm 1dB** and the blue trace is **0 $^{\circ}$ \pm 40 $^{\circ}$** .*
- Reset the REFERENCE CHANNEL ATTENUATION to **0dB** and change the TEST CHANNEL ATTENUATION to **20dB**.
- Confirm that the yellow trace is **0dB \pm 1dB** and the blue trace is **0 $^{\circ}$ \pm 40 $^{\circ}$** .*

10. Set the REFERENCE CHANNEL ATTENUATION to **20dB**.
 11. Confirm that the yellow trace is **0dB±1dB** and the blue trace is **0° ±40°**.*
 12. Set the START FREQUENCY to **3MHz** and the STOP FREQUENCY to **100MHz**.
 13. Reset the REFERENCE and TEST CHANNEL INPUT ATTENUATION to **0dB**.
 14. Allow at least one sweep to complete.
 15. Press the **COMPEN** key.
 16. Press the '**OFST REF STORE**', '**A OFFSET on/off**', and '**B OFFSET on/off**' soft-keys to turn on the offset compensation.
 17. Change the REFERENCE CHANNEL ATTENUATION to **20dB**.
 18. Confirm that the yellow trace is **0dB±2dB** and the blue trace is **0° ±70°**.*
 19. Reset REFERENCE CHANNEL ATTENUATION to **0dB** and change the TEST CHANNEL ATTENUATION to **20dB**.
 20. Confirm that the yellow trace is **0dB±2dB** and the blue trace is **0° ±70°**.*
 21. Set the REFERENCE CHANNEL ATTENUATION to **20dB**.
 22. Confirm that the yellow trace is **0dB±2dB** and the blue trace is **0° ±70°**.*
- * If either trace does not satisfy the indicated limits, troubleshoot as described in Section 8.

50Ω 20dB ATTENUATION Confirmation Check

1. Remove the feedthrough terminations from the Measurement Unit's INPUT terminals and reconnect the BNC cables.
2. Change the START FREQUENCY to **10Hz** and the STOP FREQUENCY to **3MHz**.
3. Reset the REFERENCE and TEST CHANNEL ATTENUATION to **0dB**, and set the REFERENCE and TEST CHANNEL IMPEDANCE to **50Ω**.
4. Allow at least one sweep to complete.
5. Press the **COMPEN** key.
6. Press the '**OFST REF STORE**', '**A OFFSET on/off**', and '**B OFFSET on/off**' soft-keys to turn the offset compensation on.
7. Change the REFERENCE CHANNEL ATTENUATION to **20dB**.

8. Confirm that the yellow trace is **0dB±0.25dB** and the blue trace is **0°±12°**.*
 9. Reset the REFERENCE CHANNEL ATTENUATION to **0dB** and change the TEST CHANNEL ATTENUATION to **20dB**.
 10. Confirm that the yellow trace is **0dB±0.25dB** and the blue trace is **0°±12°**.*
 11. Change the REFERENCE CHANNEL ATTENUATION to **20dB**.
 12. Confirm that the yellow trace is **0dB±0.25dB** and the blue trace is **0°±12°**.*
 13. Change the START FREQUENCY to **3MHz** and the STOP FREQUENCY to **100MHz**.
 14. Reset the REFERENCE and TEST CHANNEL INPUT ATTENUATION to **0dB**.
 15. Allow at least one sweep to complete.
 16. Press the **COMPEN** key.
 17. Press the '**OFST REF STORE**', '**A OFFSET on/off**', and '**B OFFSET on/off**' soft-keys to turn the offset compensation on.
 18. Set the REFERENCE CHANNEL ATTENUATION to **20dB**.
 19. Confirm that the yellow trace is **0dB±0.5dB** and the blue trace is **0°±24°**.*
 20. Reset the REFERENCE CHANNEL ATTENUATION to **0dB** and change the TEST CHANNEL ATTENUATION to **20dB**.
 21. Confirm that the yellow trace is **0dB±0.5dB** and the blue trace is **0°±24°**.*
 22. Change the REFERENCE CHANNEL ATTENUATION to **20dB**.
 23. Confirm that the yellow trace is **0dB±0.5dB** and the blue trace is **0°±24°**.*
- * If either trace does not satisfy the indicated limits, troubleshoot as described in Section 8.

5-18. PROCESS AMPLIFIER ADJUSTMENT

This three part procedure is for adjusting (1) the dc offsets in the mixer input signal to minimize local oscillator feedthrough, (2) the IF band-pass filter, and (3) the gain and phase of the IF amplifier.

5-18-1. IF Band-Pass Filter Coarse Adjustments

PURPOSE:

To adjust the notch frequency and flatness of the IF band-pass filter's pass band. Figure 5-34 shows the setup for these adjustments.

Note

Perform this adjustment only if any of the components directly related to the IF band-pass filter have been replaced.

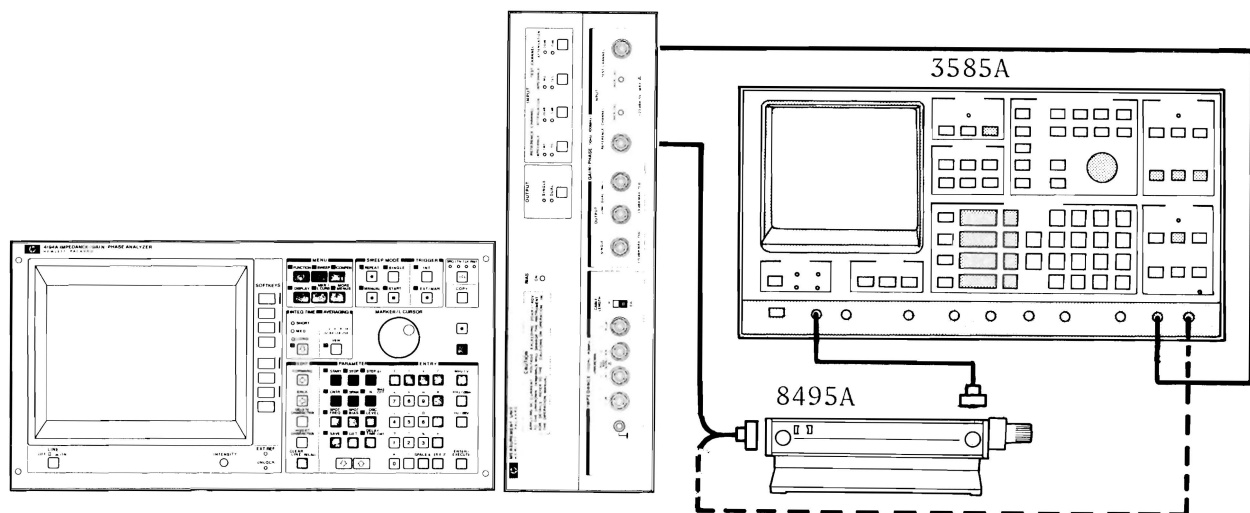

Figure 5-34. IF Band Pass Filter Coarse Adjustment Setup

EQUIPMENT:

Spectrum Analyzer
 Pad, 20dB, 50Ω
 BNC(m)-to-BNC(m) Cable, 30cm
 SMB(f)-to-BNC(m) Cable
 16349A Interconnect Cable Set

HP 3585A
 HP 8495A
 PN 8120-1839
 PN 04280-65002, 2 each

ADJUSTMENTS

PROCEDURE:

Notch Filter Third Harmonic Rejection Adjustment

1. Connect the 3585A's TRACKING GENERATOR output to the 3585A's 50Ω INPUT through a 20dB pad, as shown in Figure 5-34.

2. Set the 3585A as follows:

START FREQUENCY	0Hz
STOP FREQUENCY	781.25kHz
RANGE	10dBm
REFERENCE LEVEL	15dBm
dB/DIV	10dB/Div

3. Adjust the 3585A's TRACKING GENERATOR output level until the 50Ω INPUT level is **-26dBm±1dB**.

4. Remove the IF band-pass filter's shield cover and set jumper A21W2 to the TEST position.

5. Remove jumper A21W1 (IF GAIN) to set the IF gain to **0dB**.

6. Connect the 3585A's TRACKING GENERATOR output to A21J3 (IF IN) through a 20dB Pad.

7. Connect the 3585A's 1MΩ INPUT to A21J1 (IF OUT).

8. Set the 4194A as follows.

FUNCTION	GAIN/PHASE
FREQUENCY SPAN	0Hz
CENTER FREQUENCY	1MHz

9. Observe the 3585A's display and refer to Figure 5-35. If the rejection attenuation of the notch band (417kHz to 469kHz) is less than **60dB**, adjust A21L2 until the rejection attenuation is greater than **60dB**.

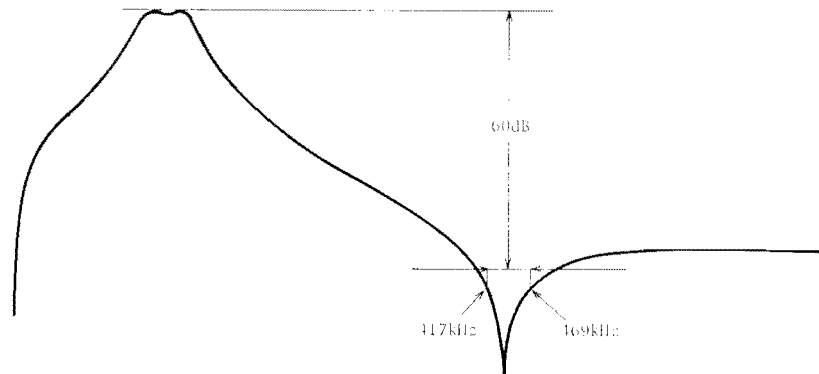

Figure 5-35. Notch Filter Adjustment

Pass Band Flatness Adjustment

1. Set the 3585A as follows:

START FREQUENCY	100kHz
STOP FREQUENCY	200kHz
Display, Vertical	1dB/DIV.

2. Observe the 3585A's display and refer to Figure 5-36. If the ripple in the pass band is greater than **0.5dB**, adjust A21L1 and L3 for minimum pass band ripple: no more than **0.5dB**.
3. If the difference in insertion loss between **138.89kHz** and **156.25kHz** is greater than **0.1dB**, adjust A21L1 and L3 for minimum insertion loss difference between these frequencies: no more than **0.1dB**. Refer to Figure 5-36.
4. Repeat steps 12 and 13 until the limits indicated in both steps are satisfied.
5. Apply a small amount of dope to A21L1 and L2 so they will not shift out of adjustment.
6. Reconnect the coaxial cables to A21J1 and J3, and reset jumpers A21W1 and W2 to the NORMAL position. Replace the shield cover.

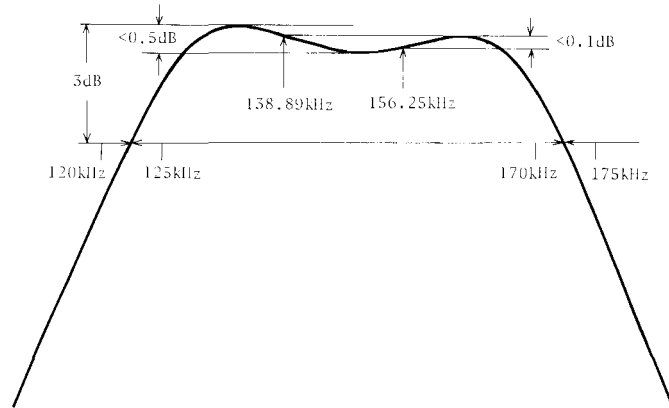

Figure 5-36. Pass Band Adjustment

5-18-2. Mixer Local Feedthrough Adjustment (Gain-Phase)

PURPOSE:

To minimize the local frequency feedthrough from the mixer by adjusting the dc offset of the gain-phase signal. Figure 5-37 shows the setup for this adjustment as well as for the adjustment described in paragraph 5-18-3.

Note

The Input Amplifier DC Offset Adjustment described in paragraph 5-17-1 must be completed before you perform this adjustment.

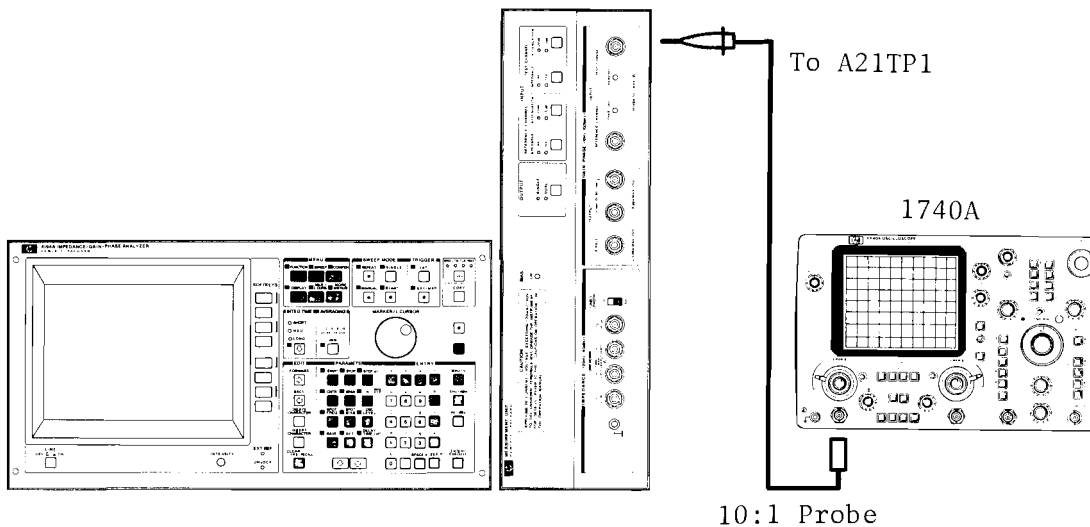

Figure 5-37. Mixer Local Feedthrough Adjustment Setup

EQUIPMENT:

Oscilloscope	HP 1740A
10:1 Divider Probe, 1M Ω	HP 10040A
16349A Interconnect Cable Set	

PROCEDURE:

1. Connect the 1740A to A21TP1.
2. Set the 1740A as follows:

INPUT	DC coupled, 1M Ω
Vertical	0.005V/DIV
TIME BASE	20us

3. Set the 4194A as follows:

FUNCTION	GAIN/PHASE
FREQUENCY SPAN	1kHz
CENTER FREQUENCY	1kHz
OSC LEVEL	-65dBm
TRIGGER	EXT/MAN

4. Adjust A21R116 until the local oscillator feedthrough (157.25kHz) is minimized.

Note

Continue on to the next adjustment without dismantling the present equipment setup.

5-18-3. Mixer Local Feedthrough Adjustment (Impedance)**PURPOSE:**

To minimize the local oscillator feedthrough from the mixer by adjusting the dc offset of the impedance signal. Figure 5-37 shows the setup for this adjustment.

PROCEDURE:

1. Set the 1740A as follows:

INPUT	DC coupled, 1M Ω
Vertical	0.01V/DIV
TIME BASE	5ms

2. Set the 4194A as follows:

FUNCTION	IMPEDANCE
START FREQUENCY	100Hz
STOP FREQUENCY	110Hz
OSC LEVEL	0.5V
AVERAGING	greater than 2
TRIGGER	EXT/MAN

3. Adjust A20R45 until the waveform on the 1740A is minimized: no more than 200mVpp.

5-18-4. IF Band-Pass Filter Fine Adjustment

PURPOSE:

To fine adjust the flatness of the IF band-pass filter. Figure 5-38 shows the setup for this adjustment.

Note

Perform this adjustment only if any components directly related to the IF band-pass filter on the A21 board have been replaced.

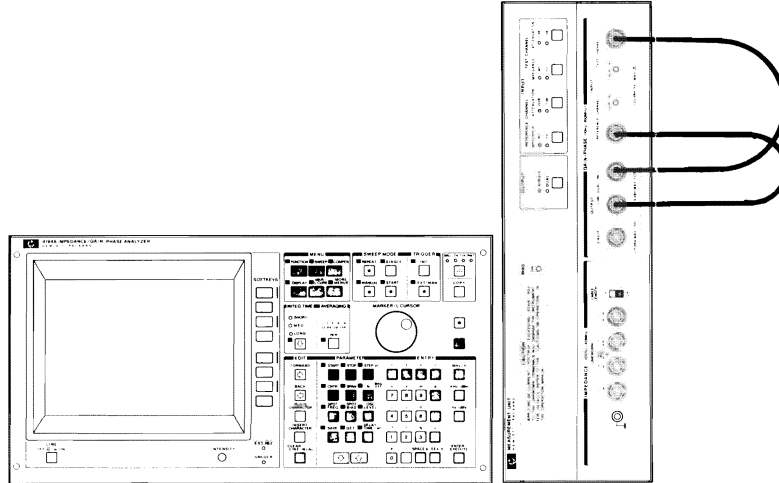

Figure 5-38. IF Band-Pass Filter Fine Adjustment Setup

EQUIPMENT:

BNC(m)-to-BNC(m) Cable, 30cm
16349A Interconnect Cable Set

PN 1820-1838, 2 each

PROCEDURE:

1. Interconnect the 4194A's DUAL OUTPUT and INPUT terminals as shown in Figure 5-38.
2. Set the 4194A as follows:

FUNCTION	GAIN/PHASE, Rch-Tch (dBm)
INTEG TIME	MED
START FREQUENCY	100kHz
STOP FREQUENCY	1MHz
OSC LEVEL	-7dBm
3. Allow at least one sweep to complete.
4. Press the **DISPLAY** key, then press the 'menu', and '**AUTO SCALE A**' softkeys.
5. Adjust A21L3 until the displayed trace is as shown in Figure 5-39. If the display looks anything like the display in Figure 5-40, adjust A21L3 until the spurs in the trace are no more than **0.002dB** in amplitude. If necessary, set AMAX and ADIV to expand the display.
6. Apply a small amount of dope to A21L3 to prevent it from shifting out of adjustment.

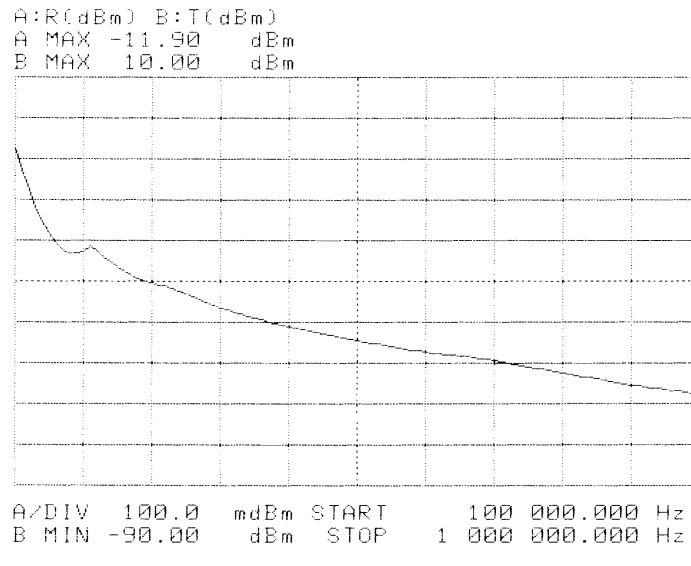

Figure 5-39. Properly Adjusted Trace

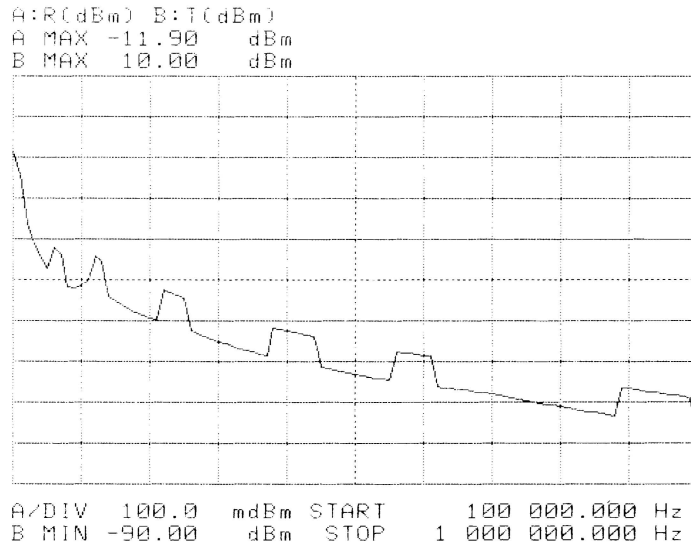

Figure 5-40. Incorrectly Adjusted Trace

5-18-5. IF Gain Adjustment

PURPOSE:

To adjust the gain ratio and phase shift of the IF amplifier. Figure 5-41 shows the setup for this adjustment.

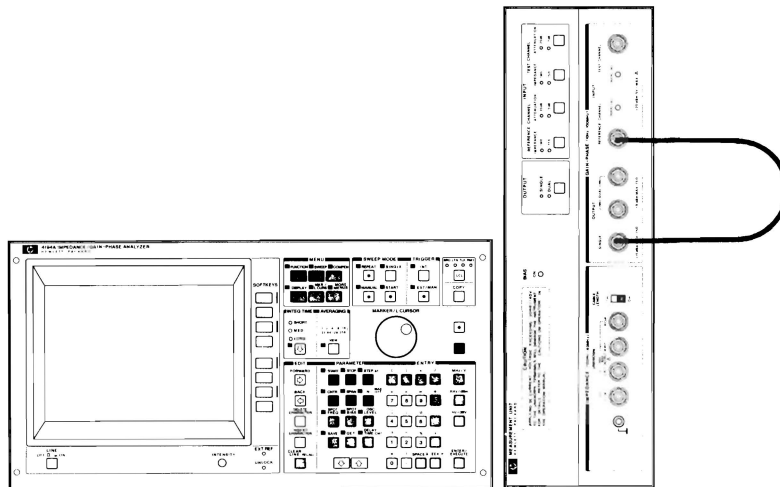

Figure 5-41. IF Gain Adjustment Setup

EQUIPMENT:

BNC(m)-to-BNC(m) Cable, 30cm
16349A Interconnect Cable Set

PN 1820-1838

PROCEDURE:

1. Interconnect the 4194A's SINGLE OUTPUT and REFERENCE CHANNEL INPUT terminals.
2. Start Self Test #40.
3. Adjust A21R24 and A21C7 until the displayed Gain is **0dB±0.0005dB** and the Phase is **0°±0.001**.

Note

If you cannot adjust the phase within the indicated limits, replace A21C9 with a 2.7pf capacitor (PN 0160-4798) and repeat this procedure from step 2.

5-19. PHASE DETECTOR TRACKING ADJUSTMENT

This procedure is for minimizing the gain and phase difference between the phase detectors and A-D converters.

PROCEDURE:

1. Set the Control Unit atop the Measurement Unit and interconnect these units with the cables furnished with the 4194A.
2. Start Self Test #10.
3. Set the test frequency to **140kHz**.
4. Adjust A9C5 (0-90 PHASE ADJ) until the Phase trace displayed on the 4194A is **1.00000±0.00004**.
5. Adjust A9R3 (0-90 GAIN ADJ) until the Gain trace displayed on the 4194A is **1.00000±0.00004**.
6. Repeat steps 4 and 5 until the limits indicated in each step are satisfied.
7. Set the 4194A's SPOT FREQ to **150kHz**.
8. Check that the displayed Gain and Phase values are within the range of **0.99995** to **1.00004**. If the displayed values are not within the indicated limits, repeat this procedure.

5-20. UPDATING DATA

This two part procedure updates Phase Tracking Test Data and Calibration Data. All Phase Tracking and Calibration Data is written to the A8U17 EEPROM.

5-20-1. Phase Tracking Test Data

PURPOSE:

To update the Phase Tracking Test Data required by the phase detectors in the bridge section. Figure 5-42 shows the setup for this procedure.

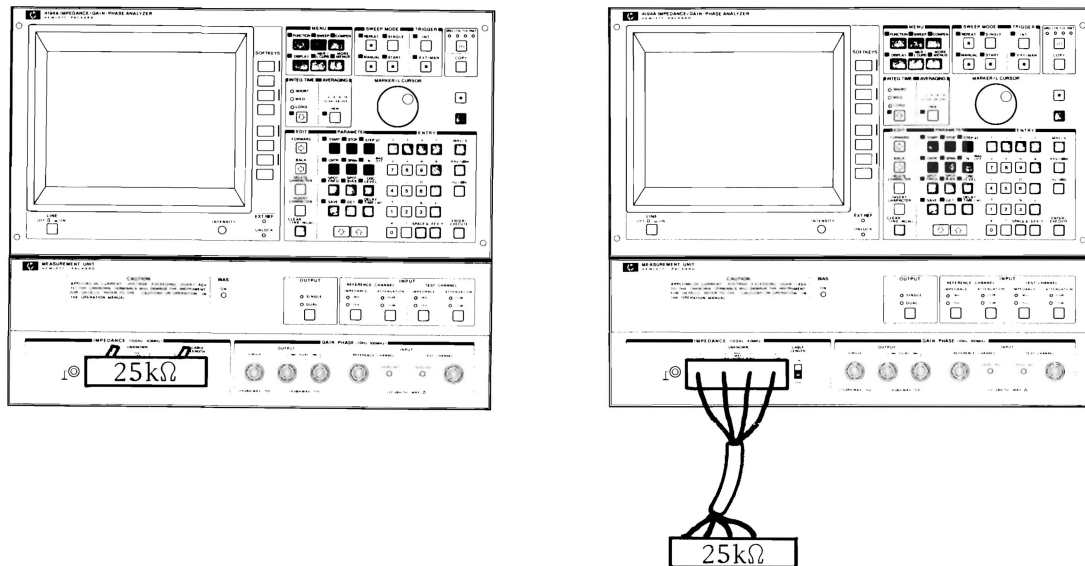

Figure 5-42. Setup for Writing Phase Tracking Test Data

EQUIPMENT:

25k Ω Resistor
BNC(m)-to-BNC(f) Cable Ass'y.

PN 16349-65004
PN 16074-61600

PROCEDURE:

1. Turn the 4194A off.
2. Remove the A8 board and set jumper A8W2 to the lowermost position, then reinstall the board.
3. Turn the 4194A on.
4. Connect the 25k Ω resistor directly to the **UNKNOWN** terminals, as shown in Figure 5-42A.

ADJUSTMENTS

5. Select self test #50.
6. Press the '**START**' softkey. The Phase Track test will begin. This test takes approximately four minutes during which time the message **PHASE TRACK test in progress** will be displayed.
7. When the Phase Track test is completed (message is no longer displayed), select self test #51.
8. Disconnect the 25k Ω resistor from the UNKNOWN terminals. Reconnect the resistor via the BNC(m)-to BNC(f) Cable Assembly, as shown in Figure 5-42B.
9. Set the CABLE LENGTH switch to 1m.
10. Press the '**START**' softkey. Once again, the Phase Track test will begin and the message **PHASE TRACK test in progress** will be displayed.
11. When the Phase Track test is completed (message is no longer displayed), turn the 4194A off and reset jumper A8W2 to its uppermost position.

5-20-2. Calibration Data

To update the remaining calibration data required to compensate measurements made with the 4194A, you'll need an HP-IB controller (HP 9826A) and the HP 16349A Product Support Package. The Product Support Package contains the required **software** and the 16349A Operation Note provides the procedure for updating calibration data.

5-21. DISPLAY ADJUSTMENTS

This eight part procedure is for adjusting the (1) output voltage of the local voltage regulator; (2) horizontal position; (3) cutoff voltages; (4) vertical and horizontal hold; (5) position, size, and pincushion distortion; (6) white balance; (7) maximum intensity; and (8) focus and convergence.

5-21-1. Local Voltage Regulator Adjustment

PURPOSE:

To adjust the local voltage regulator's output voltage. Figure 5-43 shows the setup for this adjustment.



Figure 5-43. Local Voltage Regulator Adjustment Setup

WARNING

16kV IS SUPPLIED TO THE CRT AND SOCKET. USE EXTREME CAUTION WHEN WORKING IN THE VICINITY OF THE CRT AND ITS SOCKET.

EQUIPMENT:

Digital Voltmeter
 CRT Extension Cable
 Dual Alligator-to-Alligator Clip Leads

HP 3456A
 PN 16349-61604

PROCEDURE:

1. Turn the 4194A off.
2. Remove the **MARKER/L CURSOR** knob and the Control Unit's front panel. Refer to Section 8 for instructions on how to do this.
3. Remove the CRT. Refer to Section 8.
4. Use the CRT extension cable to connect the flat cable from the motherboard to A4J3 of the CRT. Be sure to ground the chassis of the CRT section to the chassis of the Control Unit with the alligator-to-alligator clip leads.
5. Connect the 3456A's high lead to A4TP18 and the low lead to A4TP17.
6. Turn the 4194A on.
7. Adjust A4R67 (VOLT ADJ) until the reading on the 3456A is $47.5V \pm 0.1V$.
8. Turn the 4194A off and disconnect the 3456A. Go to the next adjustment without changing the setup.

5-21-2. Horizontal Position Coarse Adjustment

PURPOSE:

To adjust the horizontal display area. Figure 5-44 shows the setup.



Figure 5-44. Horizontal Position Coarse Adjustment Setup

PROCEDURE:

1. Remove the transparent safety cover from the top of the CRT section.
2. Rotate the **INTENSITY** control on the front lower right corner of the CRT section fully CCW.
3. Turn the 4194A on.
4. Rotate A17R1 (SCREEN) CW until the screen illuminates.
5. Locate the Horizontal Position Adjustment Jumper: refer to Figure 5-45. Place this jumper in one of the positions shown in the Figure so that the display is as close as possible to being centered.
6. Turn the 4194A off. Continue on to the next adjustment without changing the 4194A's setup.

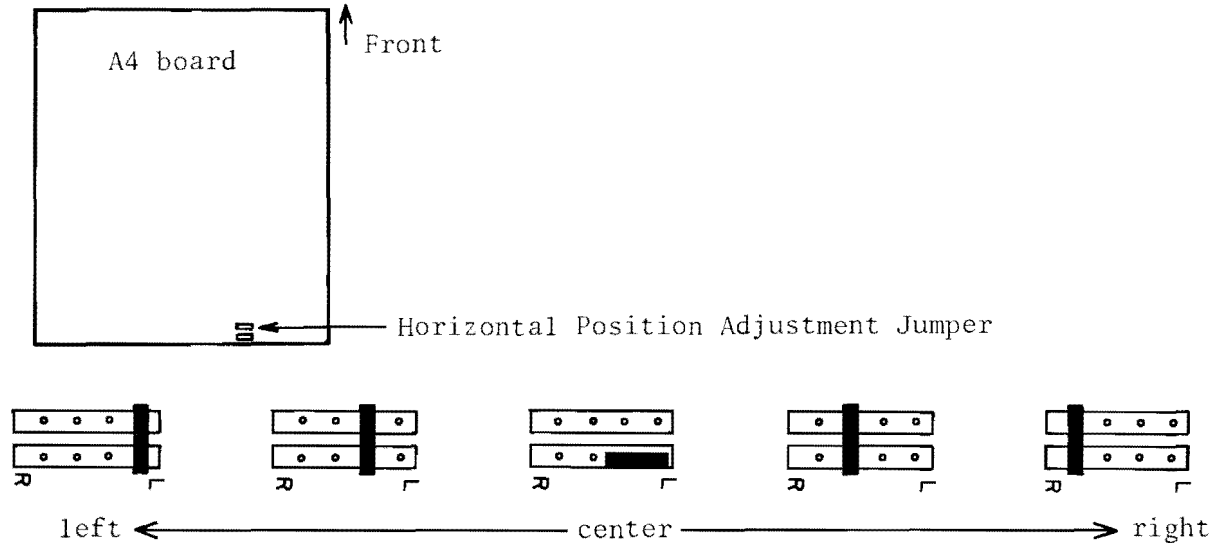

Figure 5-45. Horizontal Position Coarse Adjustment

5-21-3. CRT Cutoff Adjustment

PURPOSE:

To adjust the cutoff voltages of the red, green, and blue guns. Figure 5-46 shows the setup for this adjustment



Figure 5-46. CRT Cutoff Adjustment Setup

PROCEDURE:

1. Rotate A17R1 (SCREEN) fully CCW.
2. Rotate A5R4 (B CUTOFF) and A5R11 (G CUTOFF) fully CCW.
3. Set jumper A4W3 to the TEST position.
4. Turn the 4194A on.
5. Gradually adjust A17R1 (SCREEN) CW until the intensity of the red trace in the center of the screen is reduced considerably.
6. Adjust A5R4 (B CUTOFF) and A5R11 (G CUTOFF) until the red trace is white.

Note

If you can't adjust the trace, as described in steps 5 and 6, change A5R7 as follows:

If the trace is still red and you have set A5R4 or A5R11 fully CW, replace A5R7 with a 6.19k Ω resistor (PN 0757-0290). If the trace is still yellow and you have set A5R4 or A5R11 fully CCW, replace A5R7 with a 19.6k Ω resistor (PN 0698-3157).

7. Turn the 4194A off and unplug it. Remove the CRT extension cable.
8. Reset jumper A4W3 to the NORMAL position.
9. Rotate the **INTENSITY** control (lower-right corner of the CRT section) fully CW.
10. Replace the transparent safety cover on the CRT section.
11. Reinstall the CRT section into the Control Unit and reconnect the flat cable to A4J3.
12. Plug in the 4194A. Continue on to the next adjustment without changing the 4194A's setup.

5-21-4. Vertical and Horizontal Hold Adjustments

PURPOSE:

To adjust the vertical and horizontal hold. Figure 5-47 shows the setup for these adjustments.

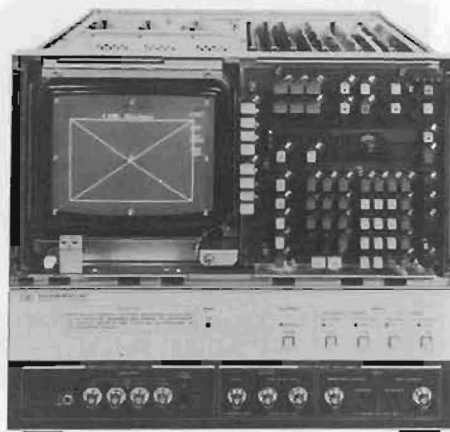

Figure 5-47. Vertical and Horizontal Hold Adjustment Setup

EQUIPMENT:

Template

PN 16349-25001

PROCEDURE:

1. Install the template over the front of the CRT, then turn the 4194A on.

2. Start Self Test #90 and adjust A4R47 (V HOLD) until the test pattern is stable at both the upper (pattern appears above the center of the screen) and lower (pattern appears below the center of the screen) V SYNC frequencies.
3. Stop and exit Self Test #90.
4. Start Self Test #81 and adjust A4R48 (H HOLD) until the test pattern is displayed in the center of the screen.
5. Stop and exit Self Test #81. Continue on to the next adjustment without changing the 4194A's setup.

5-21-5. Display Position, Size, and Pincushion Adjustments

PURPOSE:

To adjust the display's position, size, and pincushion distortion. Figure 5-48 shows the setup for these adjustments.

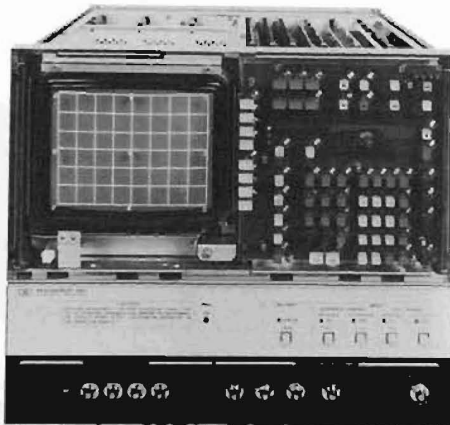

Figure 5-48. Display Position, Size, and Pincushion Adjustment Setup

PROCEDURE:

1. Start Self Test #81.
2. Adjust A4L1 (H SIZE), R45 (PIN), R46 (V SIZE), and R49 (V POS) until the test pattern is within the test limits on the template.
3. Stop and exit Self Test #81. Continue on to the next adjustment without changing the 4194A's setup.

5-21-6. White Balance Adjustment**PURPOSE:**

To adjust the balance of the red, green, and blue color drivers. Figure 5-49 shows the setup for this adjustment.

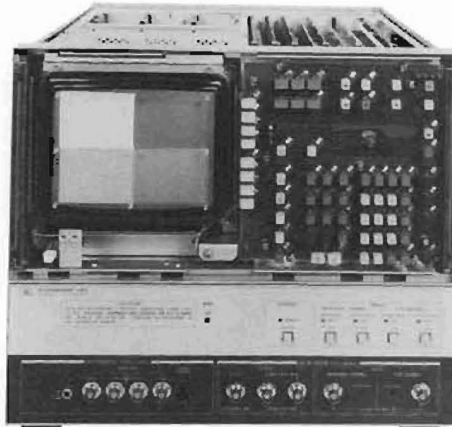

Figure 5-49. White Balance Adjustment Setup

PROCEDURE:

1. Rotate A5R34 (MAX INTEN) fully CCW and rotate the **INTENSITY** control fully CW.
2. Start Self Test #86.
3. Adjust A5R30 (BH) and R32 (GH) until the color of the lower-left area is an untinted shade of gray.
4. Adjust A5R31 (BL) and R33 (GL) until the color of the lower-right area is an untinted shade of gray).
5. Check that the color of the upper left area is white. If not, repeat steps 3 and 4 to achieve this balance.
6. Stop and exit Self Test #86. Continue on to the next adjustment without changing the 4194A's setup.

ADJUSTMENTS**5-21-7. Maximum Intensity Adjustment****PURPOSE:**

To set the 4194A's maximum intensity. Figure 5-50 shows the setup for this adjustment.

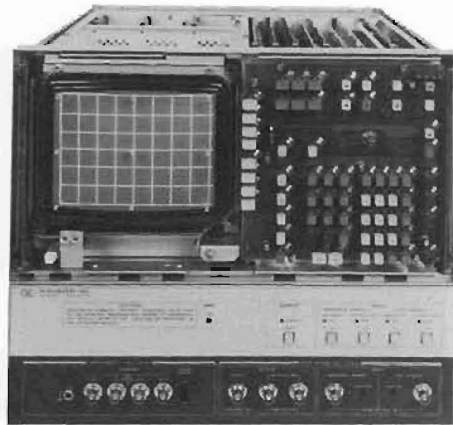

Figure 5-50. Maximum Intensity Adjustment Setup

PROCEDURE:

1. Rotate A5R34 (MAX INTEN) and the **INTENSITY** control fully CW.
2. Start Self Test #81.
3. Note the overshoot that extends to the right of each horizontal line on the displayed graticule. Adjust A5R34 (MAX INTEN) until these overshoots disappear.
4. Stop and exit Self Test #81. Continue on to the next adjustment without changing the 4194A's setup.

5-21-8. Focus, Convergence, and Intensity Adjustment**PURPOSE:**

To adjust the display's focus and convergence. Figure 5-51 shows the setup for these adjustments.

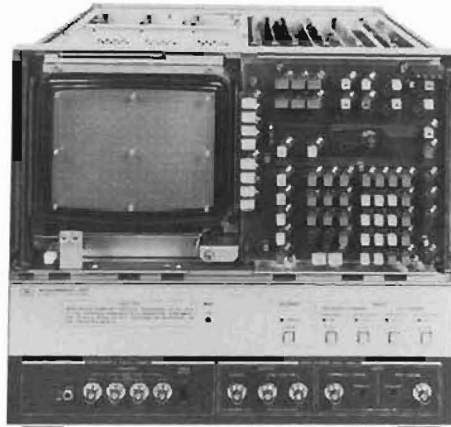

Figure 5-51. Focus and Convergence Adjustment

PROCEDURE:

1. Start Self Test #83.
2. Adjust the **CONVERGENCE** and **FOCUS** controls in the H.V. BLOCK (E1) so that the displayed Red, Green, and Blue spots are focused.
3. Stop and exit Self Test #83.
4. Turn the 4194A off.
5. Remove the template and reinstall the front panel and the **MARKER/L CURSOR** knob.
6. Turn the 4194A on.
7. Adjust the **INTENSITY** control as desired.
8. Turn the 4194A off.

**THIS
PAGE
LEFT
BLANK**

**SCANS
By
Artek Media**

SECTION 6

REPLACEABLE PARTS

6-1. INTRODUCTION

This section contains information for ordering replacement parts. Included is an explanation of the abbreviations used in the parts lists, an explanation of the parts lists themselves, basic ordering information, and the procedure for ordering parts by mail.

6-2. ABBREVIATIONS

Table 6-1 lists all abbreviations used throughout the manual. In some cases, three forms of the same abbreviation are used: all upper case, all lower case, and mixed upper and lower case. Abbreviations used in the parts lists are always upper case, whereas abbreviations in other parts of the manual may be all lower-case letters or mixed upper- and lower-case letters.

6-3. REPLACEABLE PARTS LISTS

Table 6-2 lists the names and addresses of the manufacturers identified by the Mfr. Code in the parts lists. Table 6-3 lists all printed circuit board assemblies and their components by reference designator. Tables 6-4 through 6-13 each provide an illustration of a major assembly and a listing of the assembly's components. Finally, Figure 6-1 shows an exploded view of the chassis of the Control and Measurement units and lists the part numbers of the major mechanical parts. In most cases the information given for each part includes the following:

- Hewlett-Packard part number
- Quantity in the instrument--given only once, at the first appearance of the part
- Five-digit code representing a typical manufacturer
- Manufacturer's part number

6-4. ORDERING INFORMATION

When ordering a replacement part listed in this section, specify the Hewlett-Packard part number and the quantity required, and send the order to the nearest Hewlett-Packard office.

When ordering a part not listed in this section, state the full instrument model number and serial number, describe the function of the part, and give the quantity required. Send the order to the nearest Hewlett-Packard office.

6-5. DIRECT MAIL ORDERING

Within the United States, Hewlett-Packard supplies parts through a direct mail order system. Advantages of using the system are:

- Direct order and shipment from the HP Parts Center in Mountain View, California
- No maximum or minimum on any mail order (there is a minimum order amount for parts ordered through local HP offices when the order requires billing and invoicing)
- Prepaid shipping (there is a small handling charge for each order)
- No invoices--a check or money order must accompany each order

Mail order forms and specific ordering information are available through your local HP office. Addresses and telephone numbers are given at the back of this manual.

Table 6-1. List of Reference Designators and Abbreviations

REFERENCE DESIGNATORS			
A = assembly	E = misc electronic part	P = plug	U = integrated circuit
B = motor	F = fuse	Q = transistor	V = vacuum, tube, neon bulb, photocell, etc.
BT = battery	FL = filter	R = resistor	VR = voltage regulator
C = capacitor	J = jack	RT = thermistor	W = cable
CP = coupler	K = relay	S = switch	X = socket
CR = diode	L = inductor	T = transformer	Y = crystal
DL = delay line	M = meter	TB = terminal board	
DS = device signaling (lamp)	MP = mechanical part	TP = test point	
ABBREVIATIONS			
A = amperes	H = henries	NPN = negative-positive-negative	RWV = reverse working voltage
A. F. C. = automatic frequency control	HEX = hexagonal	NRFR = not recommended for field replacement	
AMPL = amplifier	HG = mercury	NSR = not separately replaceable	S-B = slow-blow
B. F. O. = beat frequency oscillator	HR = hour(s)		SCR = screw
BE CU = beryllium copper	Hz = hertz		SE = selenium
BH = binder head	IF = intermediate freq.		SECT = section(s)
BP = bandpass	IMPG = impregnated		SEMICON = semiconductor
BRS = brass	INCD = incandescent	OBDD = order by description	SI = silicon
BWO = backward wave oscillator	INCL = include(s)	OH = oval head	SIL = silver
CCW = counter-clockwise	INS = insulation(ed)	OX = oxide	SL = slide
CER = ceramic	INT = internal		SPG = spring
CMO = cabinet mount only	k = kilo = 1000		SPL = special
COEF = coefficient	LH = left hand	P = peak	SST = stainless steel
COM = common	LIN = linear taper	PC = printed circuit	SR = split ring
COMP = composition	LK WASH = lock washer	p = pico = 10 ⁻¹²	STL = steel
COMPL = complete	LOG = logarithmic taper	PH BRZ = phosphor bronze	
CONN = connector	LPF = low pass filter	PHL = Phillips	TA = tantalum
CP = cadmium plate		PIV = peak inverse voltage	TD = time delay
CRT = cathode-ray tube	m = milli = 10 ⁻³	PNP = positive-negative-positive	TGL = toggle
CW = clockwise	M = meg = 10 ⁶	P/O = part of	THD = thread
DEPC = deposited carbon	MET FLM = metal film	POLY = polystyrene	TI = titanium
DR = drive	MET OX = metallic oxide	PORC = porcelain	TOL = tolerance
ELECT = electrolytic	MFR = manufacturer	POS = position(s)	TRIM = trimmer
ENCAP = encapsulated	MINAT = miniature	POT = potentiometer	TWT = traveling wave tube
EXT = external	MOM = momentary	PP = peak-to-peak	
F = farads	MTG = mounting	PT = point	μ = micro = 10 ⁻⁶
f = femto = 10 ⁻¹⁵	MY = "mylar"	PWV = peak working voltage	VAR = variable
FH = flat head	n = nano = 10 ⁻⁹		VDCW = dc working volts
FIL H = fillister head	N/C = normally closed	RECT = rectifier	W/ = with
FXD = fixed	NE = neon	RF = radio frequency	W = watts
G = giga = 10 ⁹	NI PL = nickel plate	RH = round head or right hand	WIV = working inverse voltage
GE = germanium	NO = normally open	RMO = rack mount only	WW = wirewound
GL = glass	NPO = negative positive zero (zero temperature coefficient)	RMS = root-mean square	W/O = without

0001-9700

Table 6-2. Component Manufacturers

Mfr. Code	Manufacturer Name	Address	ZIP Code
C0633	RIFA	BROMMA	SE
S0545	NIPPON ELECTRIC CO	TOKYO	JP
00000	ANY SATISFACTORY SUPPLIER		
01121	ALLEN-BRADLEY CO	MILWAUKEE	WI 53204
01295	TEXAS INSTR INC SEMICOND CMPNT DIV	DALLAS	TX 75222
02111	SPECTROL ELECTRONICS CORP	CITY OF IND	CA 91745
02114	FERROXCUBE CORP	SAUGERTIES	NY 12477
03888	K D I PYROFILM CORP	WHIPPANY	NJ 07981
04713	MOTOROLA SEMICONDUCTOR PRODUCTS	PHOENIX	AZ 85008
05820	WAKEFIELD ENGINEERING INC	WAKEFIELD	MA 01880
06383	PANDUIT CORP	TINLEY PARK	IL 60477
06665	PRECISION MONOLITHICS INC	SANTA CLARA	CA 95050
07263	FAIRCHILD SEMICONDUCTOR DIV	MOUNTAIN VIEW	CA 94042
08806	GE CO MINIATURE LAMP PROD DEPT	CLEVELAND	OH 44112
1B546	VARO SEMICONDUCTOR INC	GARLAND	TX 75040
11236	CTS OF BERNE INC	BERNE	IN 46711
13606	SPRAGUE ELECT CO SEMICONDUCTOR DIV	CONCORD	NH 03301
14936	GENERAL INSTR CORP SEMICON PROD GP	HICKSVILLE	NY 11802
19701	MEPCO/ELECTRA CORP	MINERAL WELLS	TX 76067
24546	CORNING GLASS WORKS (BRADFORD)	BRADFORD	PA 16701
26654	VARADYNE INC	SANTA MONICA	CA 90404
27014	NATIONAL SEMICONDUCTOR CORP	SANTA CLARA	CA 95051
28480	HEWLETT-PACKARD CO CORPORATE HQ	PALO ALTO	CA 94304
3L585	RCA CORP SOLID STATE DIV	SOMERVILLE	NJ
30161	AAVID ENGINEERING INC	LACONIA	NH 03246
32293	INTERSIL INC	CUPERTINO	CA 95014
32997	BOURNS INC TRIMPOT PROD DIV	RIVERSIDE	CA 92507
34649	INTEL CORP	MOUNTAIN VIEW	CA 95051
52063	EXAR INTEGRATED SYSTEMS INC	SUNNYVALE	CA 94086
52763	STETTNER ELECTRONICS INC	CHATTANOOGA	TN 13035
56289	SPRAGUE ELECTRIC CO	NORTH ADAMS	MA 01247
72136	ELECTRO MOTIVE CORP	FLORENCE	SC 06226
74970	JOHNSON E F CO	WASECA	MN 56093
75042	TRW INC PHILADELPHIA DIV	PHILADELPHIA	PA 19108
75915	LITTELFUSE INC	DES PLAINES	IL 60016
98291	SEAELECTRO CORP	MAMARONECK	NY 10544

Table 6-3. Replaceable Parts

Reference Designator	HP Part Number	C D	Qty.	Description	Mfr Code	Mfr Part Number
A1	04194-66501	1	1	PRIMARY RECTIFIER BOARD ASSEMBLY	28480	04194-66501
A1C1	0160-6487	9	2	CAP 1000PF 400V	28480	0160-6487
A1C2	0160-6487	9		CAP 1000PF 400V	28480	0160-6487
A1C3	0160-6488	0	2	CAP 4700PF 400V	28480	0160-6488
A1C4	0160-6488	0		CAP 4700PF 400V	28480	0160-6488
A1C5	0160-4413	7	1	CAPACITOR-FXD .6UF +-10% 250VAC(RMS)	C0633	PME271M660
A1C6	0180-3253	3	6	CAPACITOR-FXD 470UF +-20% 250VDC AL	28480	0180-3253
A1C7	0180-3253	3		CAPACITOR-FXD 470UF +-20% 250VDC AL	28480	0180-3253
A1C8	0180-3253	3		CAPACITOR-FXD 470UF +-20% 250VDC AL	28480	0180-3253
A1C9	0180-3253	3		CAPACITOR-FXD 470UF +-20% 250VDC AL	28480	0180-3253
A1C10	0180-3253	3		CAPACITOR-FXD 470UF +-20% 250VDC AL	28480	0180-3253
A1C11	0180-3253	3		CAPACITOR-FXD 470UF +-20% 250VDC AL	28480	0180-3253
A1C12	0160-3969	6	1	CAPACITOR-FXD .015UF +-20PF 250VAC(RMS)	28480	0160-3969
A1CR1	1906-0313	1	1	BRIDGE 600V	28480	1906-0313
A1CR2	1901-0050	3	1	DIODE-SWITCHING 80V 200MA 2NS DO-35	28480	1901-0050
A1DS1	1990-0486	6	2	LED-LAMP LUM-INT=1MCD IF=20MA-MAX BVR=5V	28480	5082-4684
A1DS2	1990-0486	6		LED-LAMP LUM-INT=1MCD IF=20MA-MAX BVR=5V	28480	5082-4684
A1E1	0837-0337	3	1	ARESTA 230V	28480	0837-0337
A1F1	2110-0014	3	1	FUSE 4A 250V TD 1.25X.25 UL	75915	313004
A1FT1	2110-0663	8	1	FUSE-THERMAL 96 DEG C	28480	2110-0663
A1K1	0490-1499	2	1	RELAY 12V	28480	0490-1499
A1L1	9100-1669	2	1	INDUCTOR RF-CH-MLD 4.7MH 5% .25DX.75LG	28480	9100-1669
A1L2	9140-0131	5	1	INDUCTOR RF-CH-MLD 10MH 5% .25DX.75LG	28480	9140-0131
A1L3	9140-0129	1	1	INDUCTOR RF-CH-MLD 220UH 5% .166DX.385LG	28480	9140-0129
A1L4	9100-3139	5	3	INDUCTOR 75UH 15% .5DX.875LG	28480	9100-3139
A1L5	9100-3139	5		INDUCTOR 75UH 15% .5DX.875LG	28480	9100-3139
A1L6	9100-3139	5		INDUCTOR 75UH 15% .5DX.875LG	28480	9100-3139
A1R1	0698-0085	7	2	RESISTOR 2.61K 1%		
A1R2	0764-0031	7	4	RESISTOR 47K 5% 2W MO TC=0+-200	28480	0764-0031
A1R3	0764-0031	7		RESISTOR 47K 5% 2W MO TC=0+-200	28480	0764-0031
A1R4	0764-0031	7		RESISTOR 47K 5% 2W MO TC=0+-200	28480	0764-0031
A1R5	0764-0031	7		RESISTOR 47K 5% 2W MO TC=0+-200	28480	0764-0031
A1R6	0698-0085	7		RESISTOR 2.61K 1%		
A1R7	0811-3621	8	1	RESISTOR 8 5% 6W PW TC=0+-50	28480	0811-3621
A1R8	0698-4037	0	1	RESISTOR 46.4 1% .125W F TC=0+-100	24546	C4-1/8-T0-46R4-F
A1RV1	1901-1217	6	2	VARISTOR	28480	1901-1217
A1RV2	1901-1217	6		VARISTOR	28480	1901-1217
A1X1	1252-0808	2	1	DIN CONN 96PIN M	28480	1252-0808
	4040-0748	3	1	EXTR-PC BD BLK POLYC .062-BD-THKNS	28480	4040-0748
	4040-0749	4	1	EXTR-PC BD BRN POLYC .062-BD-THKNS	28480	4040-0749

See introduction to this section for ordering information.
* Indicates factory selected value.

Table 6-3. Replaceable Parts (continued)

Reference Designator	HP Part Number	C D	Qty.	Description	Mfr Code	Mfr Part Number
A2	04194-66502	2	1	POWER SUPPLY CONTROL BOARD ASSEMBLY	28480	04194-66502
A2C1	0180-3469	3	4	CAPACITOR-FXD 100UF +-20% 25VDC AL	28480	0180-3469
A2C2	0160-4832	4	2	CAPACITOR-FXD .01UF +-10% 100VDC CER	28480	0160-4832
A2C3	0160-4824	4	1	CAPACITOR-FXD 680PF +-5% 100VDC CER	28480	0160-4824
A2C4	0160-4835	7	4	CAPACITOR-FXD .1UF +-10% 50VDC CER	28480	0160-4835
A2C5				NOT ASSIGNED		
A2C6	0160-4832	4		CAPACITOR-FXD .01UF +-10% 100VDC CER	28480	0160-4832
A2C7	0180-3469	3		CAPACITOR-FXD 100UF +-20% 25VDC AL	28480	0180-3469
A2C8	0160-4835	7		CAPACITOR-FXD .1UF +-10% 50VDC CER	28480	0160-4835
A2C9	0160-4801	7	1	CAPACITOR-FXD 100PF +-5% 100VDC CER	28480	0160-4801
A2C10	0160-5502	7	1	CAPACITOR- 1 UF 63 VDC F	28480	0160-5502
A2C11	0180-3469	3		CAPACITOR-FXD 100UF +-20% 25VDC AL	28480	0180-3469
A2C12	0180-3469	3		CAPACITOR-FXD 100UF +-20% 25VDC AL	28480	0180-3469
A2C13	0160-4835	7		CAPACITOR-FXD .1UF +-10% 50VDC CER	28480	0160-4835
A2C14	0160-4835	7		CAPACITOR-FXD .1UF +-10% 50VDC CER	28480	0160-4835
A2C15	0180-2980	1	2	CAPACITOR-FXD 1000UF +-20% 35VDC AL	28480	0180-2980
A2C16	0180-2980	1		CAPACITOR-FXD 1000UF +-20% 35VDC AL	28480	0180-2980
A2C17	0160-3969	6	2	CAPACITOR-FXD .015UF +-20PF 250VAC(RMS)	28480	0160-3969
A2C18	0160-3969	6		CAPACITOR-FXD .015UF +-20PF 250VAC(RMS)	28480	0160-3969
A2C19	0160-6403	5	1	CAP 390PF 2KV	28480	0160-6403
A2C20	0160-6363	0	2	CAPACITOR 1U 250V FILM	28480	0160-6363
A2C21	0160-6363	0		CAPACITOR 1U 250V FILM	28480	0160-6363
A2C22	0160-4822	2	2	CAPACITOR-FXD 1000PF CERM	28480	0160-4822
A2C23	0160-4822	2		CAPACITOR-FXD 1000PF CERM	28480	0160-4822
A2CR1	1901-0050	3	5	DIODE-SWITCHING 80V 200MA 2NS DO-35	28480	1901-0050
A2CR2	1902-0970	8	1	DIODE-ZNR 33V 5% DO-35 PD=.4W TC=+.097%	28480	1902-0970
A2CR3	1902-0945	7	3	DIODE-ZNR 3V 5% DO-35 PD=.4W TC=-.043%	28480	1902-0945
A2CR4	1901-0050	3		DIODE-SWITCHING 80V 200MA 2NS DO-35	28480	1901-0050
A2CR5	1902-3140	0	1	DIODE-ZNR 8.25V 2% DO-35 PD=.4W	28480	1902-3140
A2CR6	1901-0050	3		DIODE-SWITCHING 80V 200MA 2NS DO-35	28480	1901-0050
A2CR7	1902-3150	2	1	DIODE-ZNR 9.09V 2% DO-35 PD=.4W	28480	1902-3150
A2CR8	1901-0050	3		DIODE-SWITCHING 80V 200MA 2NS DO-35	28480	1901-0050
A2CR9	1902-0945	7		DIODE-ZNR 3V 5% DO-35 PD=.4W TC=-.043%	28480	1902-0945
A2CR10	1901-0050	3		DIODE-SWITCHING 80V 200MA 2NS DO-35	28480	1901-0050
A2CR11	1902-0945	7		DIODE-ZNR 3V 5% DO-35 PD=.4W TC=-.043%	28480	1902-0945
A2CR12	1906-0006	9	1	DIODE-FW BRDG 400V 1A	1B546	VE48
A2Q1	1853-0459	3	1	TRANSISTOR PNP SI PD=625MW FT=200MHZ	28480	1853-0459
A2Q2	1854-0810	2	4	TRANSISTOR NPN SI PD=625MW FT=200MHZ	28480	1854-0810
A2Q3	1854-0477	7	2	TRANSISTOR NPN 2N2222A SI TO-18 PD=500MW	04713	2N2222A
A2Q4	1853-0281	9	2	TRANSISTOR PNP 2N2907A SI TO-18 PD=400MW	04713	2N2907A
A2Q5	1854-0477	7		TRANSISTOR NPN 2N2222A SI TO-18 PD=500MW	04713	2N2222A
A2Q6	1853-0281	9		TRANSISTOR PNP 2N2907A SI TO-18 PD=400MW	04713	2N2907A
A2Q7	1854-0810	2		TRANSISTOR NPN SI PD=625MW FT=200MHZ	28480	1854-0810
A2Q8	1854-0810	2		TRANSISTOR NPN SI PD=625MW FT=200MHZ	28480	1854-0810
A2Q9	1854-0810	2		TRANSISTOR NPN SI PD=625MW FT=200MHZ	28480	1854-0810
A2Q10	1854-0389	0	1	TRANSISTOR NPN 2N4922 SI PD=30W FT=3MHZ	04713	2N4922
A2Q11	1855-0616	8	2	TRANSISTOR MOSFET N-CHAN TO-3 SI	28480	1855-0616
A2Q12	1855-0616	8		TRANSISTOR MOSFET N-CHAN TO-3 SI	28480	1855-0616

See introduction to this section for ordering information.
* Indicates factory selected value.

Table 6-3. Replaceable Parts (continued)

Reference Designator	HP Part Number	C D	Qty.	Description	Mfr Code	Mfr Part Number
A2R1	0757-0397	3	3	RESISTOR 68.1 1% .125W F TC=0+-100	24546	C4-1/8-T0-68R1-F
A2R2	0757-0280	3	4	RESISTOR 1K 1% .125W F TC=0+-100	24546	C4-1/8-T0-1001-F
A2R3	0757-0280	3		RESISTOR 1K 1% .125W F TC=0+-100	24546	C4-1/8-T0-1001-F
A2R4	0757-0419	0	2	RESISTOR 681 1% .125W F TC=0+-100	24546	C4-1/8-T0-681R-F
A2R5	0757-0199	3	2	RESISTOR 21.5K 1% .125W F TC=0+-100	24546	C4-1/8-T0-2152-F
A2R6	0757-0200	7	1	RESISTOR 5.62K 1% .125W F TC=0+-100	24546	C4-1/8-T0-5621-F
A2R7	2100-3352	7	1	RESISTOR-TRMR 1K 10% C SIDE-ADJ 1-TRN	28480	2100-3352
A2R8	2100-3274	2	1	RESISTOR-TRMR 10K 10% C SIDE-ADJ 1-TRN	28480	2100-3274
A2R9	0757-0280	3		RESISTOR 1K 1% .125W F TC=0+-100	24546	C4-1/8-T0-1001-F
A2R10	0698-0084	9	1	RESISTOR 2.15K 1% .125W F TC=0+-100	24546	C4-1/8-T0-2151-F
A2R11				NOT ASSIGNED		
A2R12	0698-3151	7	1	RESISTOR 2.87K 1% .125W F TC=0+-100	24546	C4-1/8-T0-2871-F
A2R13	0699-1704	4	2	RESISTOR 5.6 .5% .25W F TC=0+-350	28480	0699-1704
A2R14	0757-0459	8	1	RESISTOR 56.2K 1% .125W F TC=0+-100	24546	C4-1/8-T0-5622-F
A2R15	0757-0280	3		RESISTOR 1K 1% .125W F TC=0+-100	24546	C4-1/8-T0-1001-F
A2R16	0757-0199	3		RESISTOR 21.5K 1% .125W F TC=0+-100	24546	C4-1/8-T0-2152-F
A2R17	0757-0442	9	1	RESISTOR 10K 1% .125W F TC=0+-100	24546	C4-1/8-T0-1002-F
A2R18	0757-0401			RESISTOR 100 1% .125W		
A2R19	0698-3161	9	1	RESISTOR 38.3K 1% .125W F TC=0+-100	24546	C4-1/8-T0-3832-F
A2R20	0698-3455	4	2	RESISTOR 261K 1% .125W F TC=0+-100	24546	C4-1/8-T0-2613-F
A2R21	0698-3455	4		RESISTOR 261K 1% .125W F TC=0+-100	24546	C4-1/8-T0-2613-F
A2R22	0757-0397	3		RESISTOR 68.1 1% .125W F TC=0+-100	24546	C4-1/8-T0-68R1-F
A2R23	0757-0401	0	1	RESISTOR 100 1% .125W F TC=0+-100	24546	C4-1/8-T0-101-F
A2R24	0757-0397	3		RESISTOR 68.1 1% .125W F TC=0+-100	24546	C4-1/8-T0-68R1-F
A2R25	0698-3629	4	2	RESISTOR 270 5% 2W MO TC=0+-200	28480	0698-3629
A2R26	0698-3629	4		RESISTOR 270 5% 2W MO TC=0+-200	28480	0698-3629
A2R27				NOT ASSIGNED		
A2R28	0811-1553	1		RESISTOR .68 5% 2W PW TC=0+-800	75042	BWH2-11/16-J
A2R29	0699-1704	4		RESISTOR 5.6 .5% .25W F TC=0+-350	28480	0699-1704
A2R30	0698-3260	9	2	RESISTOR 464K 1% .125W F TC=0+-100	28480	0698-3260
A2R31	0698-3260	9		RESISTOR 464K 1% .125W F TC=0+-100	28480	0698-3260
A2T1	9100-4499	8	1	DRIVE TRANS	28480	9100-4499
A2U1	1813-0255	3	1	IC SW-M CKT 22 PKG	28480	1813-0255
A2U2	1826-0099	0	1	IC V RGLTR TO-220	07263	7812UC
A2W1	1251-4822	6	1	CONNECTOR 3-PIN M POST TYPE	28480	1251-4822
A2X1	1252-0808	2	1	DIN CONN 96PIN M	28480	1252-0808
	4040-0748	3	1	EXTR-PC BD BLK POLYC .062-BD-THKNS	28480	4040-0748
	4040-0750	7	1	EXTR-PC BD RED POLYC .062-BD-THKNS	28480	4040-0750

See introduction to this section for ordering information.
* Indicates factory selected value.

Table 6-3. Replaceable Parts (continued)

Reference Designator	HP Part Number	C D	Qty.	Description	Mfr Code	Mfr Part Number
A3	04194-66503	3	1	POWER SUPPLY OUTPUT BOARD ASSEMBLY	28480	04194-66503
A3C1	0160-4835	7	2	CAPACITOR-FXD .1UF +-10% 50VDC CER	28480	0160-4835
A3C2	0160-4835	7		CAPACITOR-FXD .1UF +-10% 50VDC CER	28480	0160-4835
A3C3	0180-3665	1	2	CAPACITOR-FXD 330UF +-20% 63VDC AL	28480	0180-3665
A3C4	0180-3665	1		CAPACITOR-FXD 330UF +-20% 63VDC AL	28480	0180-3665
A3C5	0160-4808	4	1	CAPACITOR-FXD 470PF +-5% 100VDC CER	28480	0160-4808
A3C6	0160-6403	5	1	CAP 390PF 2KV	28480	PPNR57280
A3C7	0180-3587	6	2	CAPACITOR-FXD 1000UF +-20% 50VDC AL	28480	0180-3587
A3C8	0180-3587	6		CAPACITOR-FXD 1000UF +-20% 50VDC AL	28480	0180-3587
A3C9	0180-1075	3	1	CAPACITOR-FXD 2200 UF 16VDC AL	28480	0180-1075
A3C10	0180-3664	0	2	CAPACITOR-FXD 3300UF +-20% 10VDC AL	28480	0180-3664
A3C11	0180-3664	0		CAPACITOR-FXD 3300UF +-20% 10VDC AL	28480	0180-3664
A3C12	0160-4832	4	1	CAPACITOR-FXD .01UF +-10% 100VDC CER	28480	0160-4832
A3CR1	1901-1065	2	7	DIODE-PWR RECT 1N4936 400V 1A 200NS	14936	1N4936
A3CR2	1902-0968	4	1	DIODE-ZNR 27V 5% DO-35 PD=.4W TC=+.095%	28480	1902-0968
A3CR3	1901-1065	2		DIODE-PWR RECT 1N4936 400V 1A 200NS	14936	1N4936
A3CR4	1902-0969	5	1	DIODE-ZNR 30V 5% DO-35 PD=.4W TC=+.095%	28480	1902-0969
A3CR5	1902-3094	3	1	DIODE-ZNR 5.11V 2% DO-35 PD=.4W	28480	1902-3094
A3CR6	1902-0956	0	1	DIODE-ZNR 8.2V 5% DO-35 PD=.4W TC=+.065%	28480	1902-0956
A3CR7	1901-0050	3	3	DIODE-SWITCHING 80V 200MA 2NS DO-35	28480	1901-0050
A3CR8	1901-1175	5	2	DIODE 400V 1.8A	28480	1901-1175
A3CR9	1901-1175	5		DIODE 400V 1.8A	28480	1901-1175
A3CR10	1901-1065	2		DIODE-PWR RECT 1N4936 400V 1A 200NS	14936	1N4936
A3CR11	1901-1065	2		DIODE-PWR RECT 1N4936 400V 1A 200NS	14936	1N4936
A3CR12	1906-0316	0	2	DIODE TWIN	28480	1906-0316
A3CR13	1906-0317	1	1	DIODE TWIN	28480	1906-0316
A3CR14	1906-0316	0		DIODE TWIN	28480	PPNR57087
A3CR15	1906-0314	2	1		28480	1906-0314
A3CR16	1901-1065	2		DIODE-PWR RECT 1N4936 400V 1A 200NS	14936	1N4936
A3CR17	1901-1065	2		DIODE-PWR RECT 1N4936 400V 1A 200NS	14936	1N4936
A3CR18	1901-1065	2		DIODE-PWR RECT 1N4936 400V 1A 200NS	14936	1N4936
A3CR19	1902-1217	8	1	DIODE-ZNR 6.2V 5% DO-4 PD=10W TC=+.035%	28480	1902-1217
A3CR20	1901-0050	3		DIODE-SWITCHING 80V 200MA 2NS DO-35	28480	1901-0050
A3CR21	1901-0050	3		DIODE-SWITCHING 80V 200MA 2NS DO-35	28480	1901-0050
A3CR22	1902-3385	5	1	DIODE-ZNR 69.8V 2%		
A3F1	2110-0099	4	2	FUSE 1A 125V .281X.093	28480	2110-0099
A3F2	2110-0099	4		FUSE 1A 125V .281X.093	28480	2110-0099
A3F3	2110-0454	5	2	FUSE 7A 125V .281X.093	28480	2110-0454
A3F4	2110-0454	5		FUSE 7A 125V .281X.093	28480	2110-0454
A3F5	2110-0592	2	3	FUSE 4A 125V NTD .281X.093	28480	2110-0592
A3F6	2110-0592	2		FUSE 4A 125V NTD .281X.093	28480	2110-0592
A3F7	2110-0592	2		FUSE 4A 125V NTD .281X.093	28480	2110-0592
A3L1	9140-1135	1	1	CH 76 UH	28480	9140-1135
A3L2	9140-1136	2	1	CH 27 MH	28480	9140-1136
A3M1	1120-1907	5	1	TIMER	28480	1120-1907
A3Q1	1853-0459	3	1	TRANSISTOR PNP SI PD=625MW FT=200MHZ	28480	1853-0459
A3Q2	1854-0810	2	2	TRANSISTOR NPN SI PD=625MW FT=200MHZ	28480	1854-0810

See introduction to this section for ordering information.
* Indicates factory selected value.

Table 6-3. Replaceable Parts (continued)

Reference Designator	HP Part Number	C D	Qty.	Description	Mfr Code	Mfr Part Number
A3Q3	1854-0810	2		TRANSISTOR NPN SI PD=625MW FT=200MHZ	28480	1854-0810
A3R1	0764-0003	3	1	RESISTOR 3.3K 5% 2W MO TC=0+-200	28480	0764-0003
A3R2	0699-1704	4	2	RESISTOR 5.6 .5% .25W F TC=0+-350	28480	0699-1704
A3R3	0683-2705	4	1	RESISTOR 27 5% .25W FC TC=-400/+500	01121	CB2705
A3R4	0698-4037	0	1	RESISTOR 46.4 1% .125W F TC=0+-100	24546	C4-1/8-T0-46R4-F
A3R5	0698-0082	7	3	RESISTOR 464 1% .125W F TC=0+-100	24546	C4-1/8-T0-4640-F
A3R6	0698-0082	7		RESISTOR 464 1% .125W F TC=0+-100	24546	C4-1/8-T0-4640-F
A3R7	0698-3438	3	1	RESISTOR 147 1% .125W F TC=0+-100	24546	C4-1/8-T0-147R-F
A3R8	0683-5655	9	1	RESISTOR 5.6M 5% .25W FC TC=-900/+1100	01121	CB5655
A3R9	0698-8961	7	1	RESISTOR 909K 1% .125W F TC=0+-100	28480	0698-8961
A3R10	0698-3159	5	1	RESISTOR 26.1K 1% .125W F TC=0+-100	24546	C4-1/8-T0-2612-F
A3R11	0757-0280	3	3	RESISTOR 1K 1% .125W F TC=0+-100	24546	C4-1/8-T0-1001-F
A3R12	0757-0280	3		RESISTOR 1K 1% .125W F TC=0+-100	24546	C4-1/8-T0-1001-F
A3R13	0698-3441	8	1	RESISTOR 215 1% .125W F TC=0+-100	24546	C4-1/8-T0-215R-F
A3R14	0698-3430	5	1	RESISTOR 21.5 1% .125W F TC=0+-100	03888	PME55-1/8-T0-21R5-F
A3R15	0811-3735	5	2	RESISTOR 470 5W	28480	0811-3735
A3R16	0811-3735	5		RESISTOR 470 5W	28480	0811-3735
A3R17	0757-0279	0	2	RESISTOR 3.16K 1% .125W F TC=0+-100	24546	C4-1/8-T0-3161-F
A3R18	0757-0279	0		RESISTOR 3.16K 1% .125W F TC=0+-100	24546	C4-1/8-T0-3161-F
A3R19	0757-0280	3		RESISTOR 1K 1% .125W F TC=0+-100	24546	C4-1/8-T0-1001-F
A3R20	0699-1704	4		RESISTOR 5.6 .5% .25W F TC=0+-350	28480	0699-1704
A3R21	0698-0082	7		RESISTOR 464 1% .125W F TC=0+-100	24546	C4-1/8-T0-4640-F
A3R22	0757-0442	9	1	RESISTOR 10K 1% .125W F TC=0+-100	24546	C4-1/8-T0-1002-F
A3R23	0757-0419	0	2	RESISTOR 681 1% .125W F TC=0+-100	24546	C4-1/8-T0-681R-F
A3R24	0757-0419	0		RESISTOR 681 1% .125W F TC=0+-100	24546	C4-1/8-T0-681R-F
A3ST1	3103-0125	3	1	THERMAL SW	28480	3103-0125
A3T1	9100-4566		1	CH 6:6 MH	28480	9100-4566
A3T2	9100-4538		1	CH 154:154:39 UH	28480	9100-4538
A3T3	9100-4562		1	MAIN TRANSFORMER	28480	9100-4562
A3U1	1990-0663	1	1	OPTO-ISOLATOR LED-PXSTR IF=40MA-MAX	28480	1990-0663
A3X1	1252-0810	6	1	DIN CONN 96PIN F	28480	1252-0810
	0340-1006	0	3	INSULATOR FOR A TO-220 PACKAGE; THERMAL	28480	0340-1006
	4040-0748	3	1	EXTR-PC BD BLK POLYC .062-BD-THKNS	28480	4040-0748
	4040-0751	8	1	EXTR-PC BD ORN POLYC .062-BD-THKNS	28480	4040-0751

See introduction to this section for ordering information.
* Indicates factory selected value.

Table 6-3. Replaceable Parts (continued)

Reference Designator	HP Part Number	C D	Qty.	Description	Mfr Code	Mfr Part Number
A4	04194-66504	4	1	CRT DEFLECTN BOARD ASSEMBLY	28480	04194-66504
A4A1	04194-66554	4	1	RC NETWORK BOARD ASSEMBLY	28480	05194-66504
A4A1C1	0160-4807	3	6	CAPACITOR-FXD 33PF	28480	0160-4807
A4A1C2	0160-4807	3		CAPACITOR-FXD 33PF	28480	0160-4807
A4A1C3	0160-4807	3		CAPACITOR-FXD 33PF	28480	0160-4807
A4A1C4	0160-4807	3		CAPACITOR-FXD 33PF	28480	0160-4807
A4A1C5	0160-4807	3		CAPACITOR-FXD 33PF	28480	0160-4807
A4A1C6	0160-4807	3		CAPACITOR-FXD 33PF	28480	0160-4807
A4A1R1	0757-0401	0	6	RESISTOR 100 1% .125W		
A4A1R2	0757-0401	0		RESISTOR 100 1% .125W		
A4A1R3	0757-0401	0		RESISTOR 100 1% .125W		
A4A1R4	0757-0401	0		RESISTOR 100 1% .125W		
A4A1R5	0757-0401	0		RESISTOR 100 1% .125W		
A4A1R6	0757-0401	0		RESISTOR 100 1% .125W		
A4C1	0160-3454	4	4	CAPACITOR-FXD 220PF +-10% 1KVDC CER	28480	0160-3454
A4C2	0160-4811	9	1	CAPACITOR-FXD 270PF +-5% 100VDC CER	28480	0160-4811
A4C3	0160-4835	7	2	CAPACITOR-FXD .1UF +-10% 50VDC CER	28480	0160-4835
A4C4	0180-3233	9	3	CAPACITOR-FXD 22 UF 25VDCW	28480	0180-3233
A4C5	0180-3233	9		CAPACITOR-FXD 22 UF 25VDCW	28480	0180-3233
A4C6	0160-4833	5	2	CAPACITOR-FXD .022UF +-10% 100VDC CER	28480	0160-4833
A4C7	0160-4835	7		CAPACITOR-FXD .1UF +-10% 50VDC CER	28480	0160-4835
A4C8	0160-4808	4	1	CAPACITOR-FXD 470PF +-5% 100VDC CER	28480	0160-4808
A4C9	0180-2697	7	4	CAPACITOR-FXD 10UF +-10% 25VDC TA	28480	0180-2697
A4C10	0160-4831	3	3	CAPACITOR-FXD 4700PF +-10% 100VDC CER	28480	0160-4831
A4C11	0180-3185	0	1	CAPACITOR-FXD 100UF +-20% 35VDC AL	28480	0180-3185
A4C12	0180-3585	4	1	CAPACITOR-FXD 1UF +-20% 250VDC AL	28480	0180-3585
A4C13	0180-2697	7		CAPACITOR-FXD 10UF +-10% 25VDC TA	28480	0180-2697
A4C14	0180-3471	7	1	CAPACITOR-FXD 470UF +-20% 25VDC AL	28480	0180-3471
A4C15	0160-4832	4	2	CAPACITOR-FXD .01UF +-10% 100VDC CER	28480	0160-4832
A4C16	0180-0291	3	1	CAPACITOR-FXD 1UF +-10% 35VDC TA	56289	150D105X9035A2
A4C17	0160-4822	2	1	CAPACITOR-FXD 1000PF +-5% 100VDC CER	28480	0160-4822
A4C18	0180-3469	3	1	CAPACITOR-FXD 100UF +-20% 25VDC AL	28480	0180-3469
A4C19	0160-6403	5	1	CAP 390PF 2KV	28480	PPNR57280
A4C20	0160-6361	8	1	CAPACITOR .82UF 200V	28480	0160-6361
A4C21	0180-3233	9		CAPACITOR-FXD 22 UF 25VDCW	28480	0180-3233
A4C22	0160-2222	2	1	CAPACITOR-FXD 1500PF +-5% 300VDC MICA	28480	0160-2222
A4C23	0160-4831	3		CAPACITOR-FXD 4700PF +-10% 100VDC CER	28480	0160-4831
A4C24	0160-2226	6	1	CAPACITOR-FXD 2200PF +-5% 300VDC MICA	28480	0160-2226
A4C25	0160-4831	3		CAPACITOR-FXD 4700PF +-10% 100VDC CER	28480	0160-4831
A4C26	0160-4832	4		CAPACITOR-FXD .01UF +-10% 100VDC CER	28480	0160-4832
A4C27	0160-4833	5		CAPACITOR-FXD .022UF +-10% 100VDC CER	28480	0160-4833
A4C28	0180-2984	5	1	CAPACITOR-FXD 47UF +-20% 50VDC AL	28480	0180-2984
A4C29	0180-1049	1	1	CAPACITOR-FXD 25.6PF	28480	0180-1049
A4C30	0180-3597	7		CAPACITOR-FXD 47UF +-20% 25VDC AL	28480	0180-3597
A4C31	0160-6362	9	1	CAPACITOR .0082U 1250V	28480	0160-6362
A4C32	0160-6402	7	1	CAP 680PF 2KV	28480	0160-6402
A4C33	0160-3454	4		CAPACITOR-FXD 220PF +-10% 1KVDC CER	28480	0160-3454

See introduction to this section for ordering information.
 * Indicates factory selected value.

Table 6-3. Replaceable Parts (continued)

Reference Designator	HP Part Number	C D	Qty.	Description	Mfr Code	Mfr Part Number
A4C34	0180-2979	8	2	CAPACITOR-FXD 220UF +-20% 16VDC AL	28480	0180-2979
A4C35	0160-3454	4		CAPACITOR-FXD 220PF +-10% 1KVDC CER	28480	0160-3454
A4C36	0180-2986	7	1	CAPACITOR-FXD 330UF +-20% 50VDC AL	28480	0180-2986
A4C37	0180-2697	7		CAPACITOR-FXD 10UF +-10% 25VDC TA	28480	0180-2697
A4C38	0160-6342	5	1	CAPACITOR 1U 100V FILM	28480	0160-6342
A4C39	0180-3657	1	1	CAPACITOR-FXD 1000UF +-20% 63VDC AL	28480	0180-3657
A4C40	0160-3877	5	2	CAPACITOR-FXD 100PF +-20% 200VDC CER	28480	0160-3877
A4C41	0160-3877	5		CAPACITOR-FXD 100PF +-20% 200VDC CER	28480	0160-3877
A4C42	0160-3454	4		CAPACITOR-FXD 220PF +-10% 1KVDC CER	28480	0160-3454
A4C43	0180-2979	8		CAPACITOR-FXD 220UF +-20% 16VDC AL	28480	0180-2979
A4C44	0160-0127	2	1	CAPACITOR-FXD 1UF +-20% 25VDC CER	28480	0160-0127
A4C45	0160-5499	1	2	CAPACITOR 0.22UF 100VDC F	28480	0160-5499
A4C46	0160-5499	1		CAPACITOR 0.22UF 100VDC F	28480	0160-5499
A4C47	0180-3658	2	1	CAPACITOR-FXD 220UF +-20% 200VDC AL	28480	0180-3658
A4C48	0180-1085	5	1	CAPACITOR-FXD 4.7UF 16VDC TA	28480	0180-1085
A4CR1	1901-0050	3	3	DIODE-SWITCHING 80V 200MA 2NS DO-35	28480	1901-0050
A4CR2	1901-0050	3		DIODE-SWITCHING 80V 200MA 2NS DO-35	28480	1901-0050
A4CR3	1901-1065	2	8	DIODE-PWR RECT 1N4936 400V 1A 200NS	14936	1N4936
A4CR4	1901-1065	2		DIODE-PWR RECT 1N4936 400V 1A 200NS	14936	1N4936
A4CR5	1902-3150	2	1	DIODE-ZNR 9.09V 2% DO-35 PD=.4W	28480	1902-3150
A4CR6	1901-1171	1	1	DIODE GH3E 1300V	28480	1901-1171
A4CR7	1901-1065	2		DIODE-PWR RECT 1N4936 400V 1A 200NS	14936	1N4936
A4CR8	1901-0050	3		DIODE-SWITCHING 80V 200MA 2NS DO-35	28480	1901-0050
A4CR9	1901-1065	2		DIODE-PWR RECT 1N4936 400V 1A 200NS	14936	1N4936
A4CR10	1901-1170	0	1	DIODE 1SS83 300V	28480	1901-1170
A4CR11	1901-1065	2		DIODE-PWR RECT 1N4936 400V 1A 200NS	14936	1N4936
A4CR12	1901-1065	2		DIODE-PWR RECT 1N4936 400V 1A 200NS	14936	1N4936
A4CR13	1901-1065	2		DIODE-PWR RECT 1N4936 400V 1A 200NS	14936	1N4936
A4CR14	1902-1286	1	1	DIODE-ZNR 1N5342B 6.8V 5% PD=5W TC=+200%	04713	1N5342B
A4CR15	1901-1065	2		DIODE-PWR RECT 1N4936 400V 1A 200NS	14936	1N4936
A4F1	2110-0099	4	1	FUSE 1A 125V .281X.093	28480	2110-0099
A4J1	1251-3837	1	1	CONNECTOR 4-PIN M UTILITY	28480	1251-3837
A4J2	1251-4938	5	1	CONNECTOR 3-PIN M METRIC POST TYPE	28480	1251-4938
A4J3	1251-3024	8	2	CONNECTOR 26-PIN M RECTANGULAR	28480	1251-3024
A4J4	1251-3024	8		CONNECTOR 26-PIN M RECTANGULAR	28480	1251-3024
A4L1	9140-1047	4	1	H WIDTH COIL	28480	9140-1047
A4L2	9140-1134	0	1	H LIN COIL	28480	9140-1134
A4L3	9140-1056	5	1	COIL 390UH	28480	9140-1056
A4L4	9100-3139	5	1	INDUCTOR 75UH 15% .5DX.875LG	28480	9100-3139
A4L5	9100-3313	7	1	INDUCTOR RF-CH-MLD 22UH 5% .166DX.385LG	28480	9100-3313
A4Q1	1854-0813	5	1	TRANSISTOR NPN 2N3501S SI TO-39 PD=1W	28480	1854-0813
A4Q2	1853-0204	6	1	TRANSISTOR PNP 2N4920 SI PD=30W FT=3MHZ	04713	2N4920
A4Q3	1853-0459	3	2	TRANSISTOR PNP SI PD=625MW FT=200MHZ	28480	1853-0459
A4Q4	1854-0810	2	2	TRANSISTOR NPN SI PD=625MW FT=200MHZ	28480	1854-0810
A4Q5	1854-1075	3	1	TRANSISTOR NPN SI TO-3 PD=50W	28480	1854-1075
A4Q6	1853-0459	3		TRANSISTOR PNP SI PD=625MW FT=200MHZ	28480	1853-0459
A4Q7	1854-0810	2		TRANSISTOR NPN SI PD=625MW FT=200MHZ	28480	1854-0810
A4Q8	1854-0389	0	1	TRANSISTOR NPN 2N4922 SI PD=30W FT=3MHZ	04713	2N4922
A4Q9	1853-0084	0	1	TRANSISTOR PNP 2N4918 SI PD=30W FT=3MHZ	04713	2N4918

See introduction to this section for ordering information.
* Indicates factory selected value.

Table 6-3. Replaceable Parts (continued)

Reference Designator	HP Part Number	C D	Qty.	Description	Mfr Code	Mfr Part Number
A4R1	0757-0274	5	2	RESISTOR 1.21K 1% .125W F TC=0+-100	24546	C4-1/8-T0-1211-F
A4R2	0698-0082	7	4	RESISTOR 464 1% .125W F TC=0+-100	24546	C4-1/8-T0-4640-F
A4R3	0698-4037	0	2	RESISTOR 46.4 1% .125W F TC=0+-100	24546	C4-1/8-T0-46R4-F
A4R4	0698-3637	4	2	RESISTOR 820 5% 2W MO TC=0+-200	28480	0698-3637
A4R5	0698-3637	4		RESISTOR 820 5% 2W MO TC=0+-200	28480	0698-3637
A4R6	0698-3401	0	1	RESISTOR 215 1% .5W F TC=0+-100	28480	0698-3401
A4R7	0757-0442	9	2	RESISTOR 10K 1% .125W F TC=0+-100	24546	C4-1/8-T0-1002-F
A4R8	0757-0399	5	1	RESISTOR 82.5 1% .125W F TC=0+-100	24546	C4-1/8-T0-82R5-F
A4R9	0757-0199	3	1	RESISTOR 21.5K 1% .125W F TC=0+-100	24546	C4-1/8-T0-2152-F
A4R10	0757-0439	4	2	RESISTOR 6.81K 1% .125W F TC=0+-100	24546	C4-1/8-T0-6811-F
A4R11	0757-0459	8	3	RESISTOR 56.2K 1% .125W F TC=0+-100	24546	C4-1/8-T0-5622-F
A4R12	0757-1094	9	1	RESISTOR 1.47K 1% .125W F TC=0+-100	24546	C4-1/8-T0-1471-F
A4R13	0698-3444	1	1	RESISTOR 316 1% .125W F TC=0+-100	24546	C4-1/8-T0-316R-F
A4R14	0757-0279	0	5	RESISTOR 3.16K 1% .125W F TC=0+-100	24546	C4-1/8-T0-3161-F
A4R15	0698-3136	8	3	RESISTOR 17.8K 1% .125W F TC=0+-100	24546	C4-1/8-T0-1782-F
A4R16	0757-0180	2	1	RESISTOR 31.6 1% .125W F TC=0+-100	28480	0757-0180
A4R17	0698-0082	7		RESISTOR 464 1% .125W F TC=0+-100	24546	C4-1/8-T0-4640-F
A4R18	0757-0280	3	2	RESISTOR 1K 1% .125W F TC=0+-100	24546	C4-1/8-T0-1001-F
A4R19	0757-0379	1	2	RESISTOR 12.1 1% .125W F TC=0+-100	19701	MF4C1/8-T0-12R1-F
A4R20	0757-0379	1		RESISTOR 12.1 1% .125W F TC=0+-100	19701	MF4C1/8-T0-12R1-F
A4R21	0698-0084	9	3	RESISTOR 2.15K 1% .125W F TC=0+-100	24546	C4-1/8-T0-2151-F
A4R22	0698-0082	7		RESISTOR 464 1% .125W F TC=0+-100	24546	C4-1/8-T0-4640-F
A4R23	0757-0441	8	5	RESISTOR 8.25K 1% .125W F TC=0+-100	24546	C4-1/8-T0-8251-F
A4R24	0757-0279	0		RESISTOR 3.16K 1% .125W F TC=0+-100	24546	C4-1/8-T0-3161-F
A4R25	0757-0441	8		RESISTOR 8.25K 1% .125W F TC=0+-100	24546	C4-1/8-T0-8251-F
A4R26	0757-0441	8		RESISTOR 8.25K 1% .125W F TC=0+-100	24546	C4-1/8-T0-8251-F
A4R27	0699-1705	5	2	RESISTOR 68 5% .25W F TC=0+-350	28480	0699-1705
A4R28	0757-0465	6	1	RESISTOR 100K 1% .125W F TC=0+-100	24546	C4-1/8-T0-1003-F
A4R29	0698-3268	7	1	RESISTOR 11.5K 1% .125W F TC=0+-100	24546	C4-1/8-T0-1152-F
A4R30	0698-3155	1	2	RESISTOR 4.64K 1% .125W F TC=0+-100	24546	C4-1/8-T0-4641-F
A4R31	0757-0279	0		RESISTOR 3.16K 1% .125W F TC=0+-100	24546	C4-1/8-T0-3161-F
A4R32	0757-0441	8		RESISTOR 8.25K 1% .125W F TC=0+-100	24546	C4-1/8-T0-8251-F
A4R33	0757-0274	5		RESISTOR 1.21K 1% .125W F TC=0+-100	24546	C4-1/8-T0-1211-F
A4R34	0757-0439	4		RESISTOR 6.81K 1% .125W F TC=0+-100	24546	C4-1/8-T0-6811-F
A4R35	0698-3159	5	2	RESISTOR 26.1K 1% .125W F TC=0+-100	24546	C4-1/8-T0-2612-F
A4R36	0757-0397	3	1	RESISTOR 68.1 1% .125W F TC=0+-100	24546	C4-1/8-T0-68R1-F
A4R37	0757-0346	2	2	RESISTOR 10 1% .125W F TC=0+-100	24546	C4-1/8-T0-10R0-F
A4R38	0757-0442	9		RESISTOR 10K 1% .125W F TC=0+-100	24546	C4-1/8-T0-1002-F
A4R39				NOT ASSIGNED		
A4R40	0757-0288	1	1	RESISTOR 9.09K 1% .125W F TC=0+-100	19701	MF4C1/8-T0-9091-F
A4R41	0698-3159	5		RESISTOR 26.1K 1% .125W F TC=0+-100	24546	C4-1/8-T0-2612-F
A4R42	0757-0441	8		RESISTOR 8.25K 1% .125W F TC=0+-100	24546	C4-1/8-T0-8251-F
A4R43	0698-3153	9	3	RESISTOR 3.83K 1% .125W F TC=0+-100	24546	C4-1/8-T0-3831-F
A4R44	0698-3404	3	1	RESISTOR 383 1% .5W F TC=0+-100	28480	0698-3404
A4R45	2100-0558	9	1	RESISTOR-TRMR 20K 10% C TOP-ADJ 1-TRN	28480	2100-0558
A4R46	2100-3383	4	1	RESISTOR-TRMR 50 10% C TOP-ADJ 1-TRN	28480	2100-3383
A4R47	2100-3252	6	3	RESISTOR-TRMR 5K 10% C TOP-ADJ 1-TRN	28480	2100-3252
A4R48	2100-3252	6		RESISTOR-TRMR 5K 10% C TOP-ADJ 1-TRN	28480	2100-3252

See introduction to this section for ordering information.
* Indicates factory selected value.

Table 6-3. Replaceable Parts (continued)

Reference Designator	HP Part Number	C D	Qty.	Description	Mfr Code	Mfr Part Number
A4R49	2100-3252	6		RESISTOR TRMR 5K 10% C TOP-ADJ 1-TRN	28480	2100-3252
A4R50	0698-3452	1	1	RESISTOR 147K 1% .125W F TC=0+-100	24546	C4-1/8-T0-1473-F
A4R51	0698-3153	9		RESISTOR 3.83K 1% .125W F TC=0+-100	24546	C4-1/8-T0-3831-F
A4R52	0698-3153	9		RESISTOR 3.83K 1% .125W F TC=0+-100	24546	C4-1/8-T0-3831-F
A4R53	0698-0082	7		RESISTOR 464 1% .125W F TC=0+-100	24546	C4-1/8-T0-4640-F
A4R54	0757-0280	3		RESISTOR 1K 1% .125W F TC=0+-100	24546	C4-1/8-T0-1001-F
A4R55	0757-0279	0		RESISTOR 3.16K 1% .125W F TC=0+-100	24546	C4-1/8-T0-3161-F
A4R56	0698-3441	8	1	RESISTOR 215 1% .125W F TC=0+-100	24546	C4-1/8-T0-215R-F
A4R57	0757-0459	8		RESISTOR 56.2K 1% .125W F TC=0+-100	24546	C4-1/8-T0-5622-F
A4R58	0698-3438	3	1	RESISTOR 147 1% .125W F TC=0+-100	24546	C4-1/8-T0-147R-F
A4R59	0699-1704	4	3	RESISTOR 5.6 .5% .25W F TC=0+-350	28480	0699-1704
A4R60	0699-1704	4		RESISTOR 5.6 .5% .25W F TC=0+-350	28480	0699-1704
A4R61	0757-0279	0		RESISTOR 3.16K 1% .125W F TC=0+-100	24546	C4-1/8-T0-3161-F
A4R62	0757-0459	8		RESISTOR 56.2K 1% .125W F TC=0+-100	24546	C4-1/8-T0-5622-F
A4R63	0764-0042	0	1	RESISTOR 2.2K 5% 2W MO TC=0+-200	28480	0764-0042
A4R64	0698-3132	4	1	RESISTOR 261 1% .125W F TC=0+-100	24546	C4-1/8-T0-2610-F
A4R65	0698-3136	8		RESISTOR 17.8K 1% .125W F TC=0+-100	24546	C4-1/8-T0-1782-F
A4R66	0698-3136	8		RESISTOR 17.8K 1% .125W F TC=0+-100	24546	C4-1/8-T0-1782-F
A4R67	2100-0567	0	1	RESISTOR TRMR 2K 10% C TOP-ADJ 1-TRN	28480	2100-0567
A4R68	0757-0417	8	2	RESISTOR 562 1% .125W F TC=0+-100	24546	C4-1/8-T0-562R-F
A4R69	0698-4037	0		RESISTOR 46.4 1% .125W F TC=0+-100	24546	C4-1/8-T0-46R4-F
A4R70	0699-1704	4		RESISTOR 5.6 .5% .25W F TC=0+-350	28480	0699-1704
A4R71	0698-3155	1		RESISTOR 4.64K 1% .125W F TC=0+-100	24546	C4-1/8-T0-4641-F
A4R72	0698-0084	9		RESISTOR 2.15K 1% .125W F TC=0+-100	24546	C4-1/8-T0-2151-F
A4R73	0757-0417	8		RESISTOR 562 1% .125W F TC=0+-100	24546	C4-1/8-T0-562R-F
A4R74	0698-0084	9		RESISTOR 2.15K 1% .125W F TC=0+-100	24546	C4-1/8-T0-2151-F
A4R75	0757-0346	2		RESISTOR 10 1% .125W F TC=0+-100	24546	C4-1/8-T0-10R0-F
A4R76	0699-1705	5		RESISTOR 68 5% .25W F TC=0+-350	28480	0699-1705
A4R77	0698-3428	1	1	RESISTOR 14.7 1% .125W F TC=0+-100	03888	PME55-1/8-T0-14R7-F
A4R78				NOT ASSIGNED		
A4T1	9100-4498	1	1	TRANS H. DRIVE	28480	9100-4498
A4T2	9100-4487	8	1	PINCUSHION TRANSFORMER	28480	9100-4487
A4U1	1826-1345	1	1	IC MISC PLSTC-SIL PKG	28480	1826-1345
A4U2	1826-1344	0	1	IC MISC 18-DIP-P PKG	28480	1826-1344
A4U3	1826-0393	7	1	IC V RGLTR-ADJ-POS 1.2/37V TO-220 PKG	28480	1826-0393
A4U4	1820-1199	1	1	IC INV TTL LS HEX 1-INP	01295	SN74LS04N
A4U5	1826-0122	0	1	IC 7805 V RGLTR TO-220	07263	7805UC
A4W1	1251-4484	6	2	CONNECTOR 4-PIN M POST TYPE	28480	1251-4484
A4W2	1251-4484	6		CONNECTOR 4-PIN M POST TYPE	28480	1251-4484
A4W3	1251-4822	6	1	CONNECTOR 3-PIN M POST TYPE	28480	1251-4822

See introduction to this section for ordering information.
* Indicates factory selected value.

Table 6-3. Replaceable Parts (continued)

Reference Designator	HP Part Number	C D	Qty.	Description	Mfr Code	Mfr Part Number
A5	04194-66505	5	1	VIDEO AMPLIFIER BOARD ASSEMBLY	28480	04194-66505
A5C1	0180-3465	9	4	CAPACITOR-FXD 4.7UF +-20% 100VDC AL	28480	0180-3465
A5C2	0180-3465	9		CAPACITOR-FXD 4.7UF +-20% 100VDC AL	28480	0180-3465
A5C3	0180-3465	9		CAPACITOR-FXD 4.7UF +-20% 100VDC AL	28480	0180-3465
A5C4	0160-4299	7	1	CAPACITOR-FXD 2200PF +-20% 250VDC CER	56289	C067F251F222MS22-CDH
A5C5	0170-0040	9	3	CAPACITOR-FXD .047UF +-10% 200VDC POLYE	56289	292P47392
A5C6	0170-0040	9		CAPACITOR-FXD .047UF +-10% 200VDC POLYE	56289	292P47392
A5C7	0170-0040	9		CAPACITOR-FXD .047UF +-10% 200VDC POLYE	56289	292P47392
A5C8	0180-3465	9		CAPACITOR-FXD 4.7UF +-20% 100VDC AL	28480	0180-3465
A5C9	0160-3622	8	1	CAPACITOR-FXD .1UF +80-20% 100VDC CER	26654	2130Y5V100R104Z
A5C10	0180-1085	5	1	CAPACITOR-FXD 4.7UF 16VDC TA	28480	0180-1085
A5C11	0160-4832	4	2	CAPACITOR-FXD .01UF +-10% 100VDC CER	28480	0160-4832
A5C12	0160-6360	7	1	CAPACITOR 2.2U .250V	28480	0160-6360
A5C13	0180-2984	5	1	CAPACITOR-FXD 47UF +-20% 50VDC AL	28480	0180-2984
A5C14	0160-4832	4		CAPACITOR-FXD .01UF +-10% 100VDC CER	28480	0160-4832
A5C15	0160-0127	2	1	CAPACITOR-FXD 1UF +-20% 25VDC CER	28480	0160-0127
A5C16	0180-2697	7	1	CAPACITOR-FXD 10UF +-10% 25VDC TA	28480	0180-2697
A5CR1	1901-1170	0	9	DIO 1SS83 300V	28480	1901-1170
A5CR2	1901-1170	0		DIO 1SS83 300V	28480	1901-1170
A5CR3	1901-1170	0		DIO 1SS83 300V	28480	1901-1170
A5CR4	1901-1170	0		DIO 1SS83 300V	28480	1901-1170
A5CR5	1901-1170	0		DIO 1SS83 300V	28480	1901-1170
A5CR6	1901-1170	0		DIO 1SS83 300V	28480	1901-1170
A5CR7	1901-1170	0		DIO 1SS83 300V	28480	1901-1170
A5CR8	1901-1170	0		DIO 1SS83 300V	28480	1901-1170
A5CR9	1901-1170	0		DIO 1SS83 300V	28480	1901-1170
A5CR10	1901-0050	3	1	DIODE-SWITCHING 80V 200MA 2NS DO-35	28480	1901-0050
A5CR11	1902-0953	7	2	DIODE-ZNR 6.2V 5% DO-35 PD=.4W TC=+.053%	28480	1902-0953
A5CR12	1902-0953	7		DIODE-ZNR 6.2V 5% DO-35 PD=.4W TC=+.053%	28480	1902-0953
A5J1	1251-6527	2	1	CONNECTOR 6-PIN M METRIC POST TYPE	28480	1251-6527
A5J2	0362-0390	9	1	CABLE TRANSITION 26-TERM INSUL DSPL TYPE	28480	0362-0390
A5J3	1251-4938	5	1	CONNECTOR 3-PIN M METRIC POST TYPE	28480	1251-4938
A5J4	1251-5862	6	1	CONNECTOR 4-PIN M METRIC POST TYPE	28480	1251-5862
A5L1	9140-0114	4	4	INDUCTOR RF-CH-MLD 10UH 10% .166DX.385LG	28480	9140-0114
A5L2	9140-0114	4		INDUCTOR RF-CH-MLD 10UH 10% .166DX.385LG	28480	9140-0114
A5L3	9140-0114	4		INDUCTOR RF-CH-MLD 10UH 10% .166DX.385LG	28480	9140-0114
A5L4	9140-0114	4		INDUCTOR RF-CH-MLD 10UH 10% .166DX.385LG	28480	9140-0114
A5L5	9140-0672	9	1	INDUCTOR 2.2MH 20%	28480	9140-0672
A5Q1	1853-0591	4	3	TRANSISTOR PNP SI PD=1W FT=50MHZ	28480	1853-0591
A5Q2	1854-1076	4	6	TRANSISTOR NPN SI PD=1W FT=50MHZ	28480	1854-1076
A5Q3	1853-0591	4		TRANSISTOR PNP SI PD=1W FT=50MHZ	28480	1853-0591
A5Q4	1854-1076	4		TRANSISTOR NPN SI PD=1W FT=50MHZ	28480	1854-1076
A5Q5	1853-0591	4		TRANSISTOR PNP SI PD=1W FT=50MHZ	28480	1853-0591
A5Q6	1854-1076	4		TRANSISTOR NPN SI PD=1W FT=50MHZ	28480	1854-1076
A5Q7	1854-1076	4		TRANSISTOR NPN SI PD=1W FT=50MHZ	28480	1854-1076
A5Q8	1854-1076	4		TRANSISTOR NPN SI PD=1W FT=50MHZ	28480	1854-1076
A5Q9	1854-1076	4		TRANSISTOR NPN SI PD=1W FT=50MHZ	28480	1854-1076
A5Q10	1854-1080	0	1	TRANSISTOR NPN SI DARL TO-220AB PD=40W	28480	1854-1080

See introduction to this section for ordering information.
 * Indicates factory selected value.

Table 6-3. Replaceable Parts (continued)

Reference Designator	HP Part Number	C D	Qty.	Description	Mfr Code	Mfr Part Number
A5Q11	1854-0810	2	3	TRANSISTOR NPN SI PD=625MW FT=200MHZ	28480	1854-0810
A5Q12	1854-0810	2		TRANSISTOR NPN SI PD=625MW FT=200MHZ	28480	1854-0810
A5Q13	1854-0810	2		TRANSISTOR NPN SI PD=625MW FT=200MHZ	28480	1854-0810
A5Q14	1855-0612	4	1	TRANSISTOR-UJT TO-92	28480	1855-0612
A5R1	0698-3452	1	3	RESISTOR 147K 1% .125W F TC=0+-100	24546	C4-1/8-T0-1473-F
A5R2	0698-3452	1		RESISTOR 147K 1% .125W F TC=0+-100	24546	C4-1/8-T0-1473-F
A5R3	0698-3452	1		RESISTOR 147K 1% .125W F TC=0+-100	24546	C4-1/8-T0-1473-F
A5R4	2100-3353	8	2	RESISTOR-TRMR 20K 10% C SIDE-ADJ 1-TRN	28480	2100-3353
A5R5	0757-1094	9	3	RESISTOR 1.47K 1% .125W F TC=0+-100	24546	C4-1/8-T0-1471-F
A5R6	0757-1094	9		RESISTOR 1.47K 1% .125W F TC=0+-100	24546	C4-1/8-T0-1471-F
A5R7	0757-0444	1	1	RESISTOR 12.1K 1% .125W F TC=0+-100	24546	C4-1/8-T0-1212-F
A5R8	0698-3419	0	2	RESISTOR 31.6K 1% .5W F TC=0+-100	28480	0698-3419
A5R9	0698-3419	0		RESISTOR 31.6K 1% .5W F TC=0+-100	28480	0698-3419
A5R10	0698-3423	6	1	RESISTOR 46.4K 1% .5W F TC=0+-100	28480	0698-3423
A5R11	2100-3353	8		RESISTOR-TRMR 20K 10% C SIDE-ADJ 1-TRN	28480	2100-3353
A5R12	0698-3446	3	3	RESISTOR 383 1% .125W F TC=0+-100	24546	C4-1/8-T0-383R-F
A5R13	0698-3446	3		RESISTOR 383 1% .125W F TC=0+-100	24546	C4-1/8-T0-383R-F
A5R14	0698-3446	3		RESISTOR 383 1% .125W F TC=0+-100	24546	C4-1/8-T0-383R-F
A5R15	0699-1705	5	6	RESISTOR 68 5% .25W F TC=0+-350	28480	0699-1705
A5R16	0699-1705	5		RESISTOR 68 5% .25W F TC=0+-350	28480	0699-1705
A5R17	0699-1705	5		RESISTOR 68 5% .25W F TC=0+-350	28480	0699-1705
A5R18	0699-1705	5		RESISTOR 68 5% .25W F TC=0+-350	28480	0699-1705
A5R19	0699-1705	5		RESISTOR 68 5% .25W F TC=0+-350	28480	0699-1705
A5R20	0699-1705	5		RESISTOR 68 5% .25W F TC=0+-350	28480	0699-1705
A5R21	0698-3132	4	3	RESISTOR 261 1% .125W F TC=0+-100	24546	C4-1/8-T0-2610-F
A5R22	0698-3440	7	2	RESISTOR 196 1% .125W F TC=0+-100	24546	C4-1/8-T0-196R-F
A5R23	0698-3132	4		RESISTOR 261 1% .125W F TC=0+-100	24546	C4-1/8-T0-2610-F
A5R24	0698-3159	5	3	RESISTOR 26.1K 1% .125W F TC=0+-100	24546	C4-1/8-T0-2612-F
A5R25	0698-3440	7		RESISTOR 196 1% .125W F TC=0+-100	24546	C4-1/8-T0-196R-F
A5R26	0698-3132	4		RESISTOR 261 1% .125W F TC=0+-100	24546	C4-1/8-T0-2610-F
A5R27	0698-3159	5		RESISTOR 26.1K 1% .125W F TC=0+-100	24546	C4-1/8-T0-2612-F
A5R28	0698-3159	5		RESISTOR 26.1K 1% .125W F TC=0+-100	24546	C4-1/8-T0-2612-F
A5R29	0698-0082	7	1	RESISTOR 464 1% .125W F TC=0+-100	24546	C4-1/8-T0-4640-F
A5R30	2100-3350	5	2	RESISTOR-TRMR 200 10% C SIDE-ADJ 1-TRN	28480	2100-3350
A5R31	2100-3351	6	2	RESISTOR-TRMR 500 10% C SIDE-ADJ 1-TRN	28480	2100-3351
A5R32	2100-3350	5		RESISTOR-TRMR 200 10% C SIDE-ADJ 1-TRN	28480	2100-3350
A5R33	2100-3351	6		RESISTOR-TRMR 500 10% C SIDE-ADJ 1-TRN	28480	2100-3351
A5R34	2100-3207	1	1	RESISTOR-TRMR 5K 10% C SIDE-ADJ 1-TRN	28480	2100-3207
A5R35	0764-0042	0	3	RESISTOR 2.2K 5% 2W MO TC=0+-200	28480	0764-0042
A5R36	0764-0042	0		RESISTOR 2.2K 5% 2W MO TC=0+-200	28480	0764-0042
A5R37	0764-0042	0		RESISTOR 2.2K 5% 2W MO TC=0+-200	28480	0764-0042
A5R38	0757-0442	9	1	RESISTOR 10K 1% .125W F TC=0+-100	24546	C4-1/8-T0-1002-F
A5R39	0698-0085	0	1	RESISTOR 2.61K 1% .125W F TC=0+-100	24546	C4-1/8-T0-2611-F
A5R40	0757-0461	2	1	RESISTOR 68.1K 1% .125W F TC=0+-100	24546	C4-1/8-T0-6812-F
A5R41	0757-0401	0	1	RESISTOR 100 1% .125W F TC=0+-100	24546	C4-1/8-T0-101-F
A5R42	0698-3156	2	1	RESISTOR 14.7K 1% .125W F TC=0+-100	24546	C4-1/8-T0-1472-F
A5R43	0698-3444	1	1	RESISTOR 316 1% .125W F TC=0+-100	24546	C4-1/8-T0-316R-F
A5R44	0757-0465	6	1	RESISTOR 100K 1% .125W F TC=0+-100	24546	C4-1/8-T0-1003-F

See introduction to this section for ordering information.
* Indicates factory selected value.

Table 6-3. Replaceable Parts (continued)

Reference Designator	HP Part Number	C D	Qty.	Description	Mfr Code	Mfr Part Number
A5R45	0757-1094	9		RESISTOR 1.47K 1% .125W F TC=0+-100	24546	C4-1/8-T0-1471-F
A5R46	0698-3162	0	1	RESISTOR 46.4K 1% .125W F TC=0+-100	24546	C4-1/8-T0-4642-F
A5R47	0757-0280	3	1	RESISTOR 1K 1% .125W F TC=0+-100	24546	C4-1/8-T0-1001-F
A5U1	1820-0684	7	1	IC INV TTL S HEX 1-INP	01295	SN74S05N

See introduction to this section for ordering information.
 * Indicates factory selected value.

Table 6-3. Replaceable Parts (continued)

Reference Designator	HP Part Number	C D	Qty.	Description	Mfr Code	Mfr Part Number
A6	04194-66506	6	1	DATA MANIPULATION PROCESSOR BOARD ASSEMBLY	28480	04194-66506
A6BT1	1420-0306	2	1	BATTERY- 2.4V	28480	1420-0306
A6C1	0160-4832	4	46	CAPACITOR-FXD .01UF +-10% 100VDC CER	28480	0160-4832
A6C2	0160-4832	4		CAPACITOR-FXD .01UF +-10% 100VDC CER	28480	0160-4832
A6C3	0160-4832	4		CAPACITOR-FXD .01UF +-10% 100VDC CER	28480	0160-4832
A6C4	0160-4832	4		CAPACITOR-FXD .01UF +-10% 100VDC CER	28480	0160-4832
A6C5	0160-4832	4		CAPACITOR-FXD .01UF +-10% 100VDC CER	28480	0160-4832
A6C6	0160-4832	4		CAPACITOR-FXD .01UF +-10% 100VDC CER	28480	0160-4832
A6C7	0160-4832	4		CAPACITOR-FXD .01UF +-10% 100VDC CER	28480	0160-4832
A6C8	0160-4832	4		CAPACITOR-FXD .01UF +-10% 100VDC CER	28480	0160-4832
A6C9	0160-4832	4		CAPACITOR-FXD .01UF +-10% 100VDC CER	28480	0160-4832
A6C10	0160-4832	4		CAPACITOR-FXD .01UF +-10% 100VDC CER	28480	0160-4832
A6C11	0160-4832	4		CAPACITOR-FXD .01UF +-10% 100VDC CER	28480	0160-4832
A6C12	0160-4832	4		CAPACITOR-FXD .01UF +-10% 100VDC CER	28480	0160-4832
A6C13	0160-4832	4		CAPACITOR-FXD .01UF +-10% 100VDC CER	28480	0160-4832
A6C14	0160-4832	4		CAPACITOR-FXD .01UF +-10% 100VDC CER	28480	0160-4832
A6C15	0160-4832	4		CAPACITOR-FXD .01UF +-10% 100VDC CER	28480	0160-4832
A6C16	0160-4832	4		CAPACITOR-FXD .01UF +-10% 100VDC CER	28480	0160-4832
A6C17	0160-4832	4		CAPACITOR-FXD .01UF +-10% 100VDC CER	28480	0160-4832
A6C18	0160-4832	4		CAPACITOR-FXD .01UF +-10% 100VDC CER	28480	0160-4832
A6C19	0160-4832	4		CAPACITOR-FXD .01UF +-10% 100VDC CER	28480	0160-4832
A6C20	0160-4832	4		CAPACITOR-FXD .01UF +-10% 100VDC CER	28480	0160-4832
A6C21	0160-4832	4		CAPACITOR-FXD .01UF +-10% 100VDC CER	28480	0160-4832
A6C22	0160-4832	4		CAPACITOR-FXD .01UF +-10% 100VDC CER	28480	0160-4832
A6C23	0160-4832	4		CAPACITOR-FXD .01UF +-10% 100VDC CER	28480	0160-4832
A6C24	0160-4832	4		CAPACITOR-FXD .01UF +-10% 100VDC CER	28480	0160-4832
A6C25	0160-4832	4		CAPACITOR-FXD .01UF +-10% 100VDC CER	28480	0160-4832
A6C26	0160-4832	4		CAPACITOR-FXD .01UF +-10% 100VDC CER	28480	0160-4832
A6C27	0160-4832	4		CAPACITOR-FXD .01UF +-10% 100VDC CER	28480	0160-4832
A6C28	0160-4832	4		CAPACITOR-FXD .01UF +-10% 100VDC CER	28480	0160-4832
A6C29	0160-4832	4		CAPACITOR-FXD .01UF +-10% 100VDC CER	28480	0160-4832
A6C30	0160-4832	4		CAPACITOR-FXD .01UF +-10% 100VDC CER	28480	0160-4832
A6C31	0160-4832	4		CAPACITOR-FXD .01UF +-10% 100VDC CER	28480	0160-4832
A6C32	0160-4832	4		CAPACITOR-FXD .01UF +-10% 100VDC CER	28480	0160-4832
A6C33	0160-4832	4		CAPACITOR-FXD .01UF +-10% 100VDC CER	28480	0160-4832
A6C34	0160-4832	4		CAPACITOR-FXD .01UF +-10% 100VDC CER	28480	0160-4832
A6C35	0160-4832	4		CAPACITOR-FXD .01UF +-10% 100VDC CER	28480	0160-4832
A6C36	0160-4832	4		CAPACITOR-FXD .01UF +-10% 100VDC CER	28480	0160-4832
A6C37	0160-4832	4		CAPACITOR-FXD .01UF +-10% 100VDC CER	28480	0160-4832
A6C38	0160-4832	4		CAPACITOR-FXD .01UF +-10% 100VDC CER	28480	0160-4832
A6C39	0160-4832	4		CAPACITOR-FXD .01UF +-10% 100VDC CER	28480	0160-4832
A6C40	0160-4832	4		CAPACITOR-FXD .01UF +-10% 100VDC CER	28480	0160-4832
A6C41	0180-0229	7	1	CAPACITOR-FXD 33UF +-10% 10VDC TA	56289	150D336X9010B2
A6C42	0160-4835	7	2	CAPACITOR-FXD .1UF +-10% 50VDC CER	28480	0160-4835
A6C43	0160-4835	7		CAPACITOR-FXD .1UF +-10% 50VDC CER	28480	0160-4835
A6C44	0180-3217	9	3	CAPACITOR-FXD 470UF	28480	0180-3217
A6C45	0180-0376	5	2	CAPACITOR-FXD .47UF +-10% 35VDC TA	56289	150D474X9035A2
A6C46	0180-0376	5		CAPACITOR-FXD .47UF +-10% 35VDC TA	56289	150D474X9035A2

See introduction to this section for ordering information.
 * Indicates factory selected value.

Table 6-3. Replaceable Parts (continued)

Reference Designator	HP Part Number	C D	Qty.	Description	Mfr Code	Mfr Part Number
A6C47	0180-3469	3	1	CAPACITOR-FXD 100UF +-20% 25VDC AL	28480	0180-3469
A6C48	0160-4832	4		CAPACITOR-FXD .01UF +-10% 100VDC CER	28480	0160-4832
A6C49	0160-4832	4		CAPACITOR-FXD .01UF +-10% 100VDC CER	28480	0160-4832
A6C50	0160-4832	4		CAPACITOR-FXD .01UF +-10% 100VDC CER	28480	0160-4832
A6C51	0160-4832	4		CAPACITOR-FXD .01UF +-10% 100VDC CER	28480	0160-4832
A6C52	0160-4832	4		CAPACITOR-FXD .01UF +-10% 100VDC CER	28480	0160-4832
A6C53	0160-4832	4		CAPACITOR-FXD .01UF +-10% 100VDC CER	28480	0160-4832
A6C54	0180-0291	3	1	CAPACITOR-FXD 1UF +-10% 35VDC TA	56289	150D105X9035A2
A6C55	0180-3217	9		CAPACITOR-FXD 470UF	28480	0180-3217
A6C56	0180-3217	9		CAPACITOR-FXD 470UF	28480	0180-3217
A6CR1	1901-0518	8	3	DIODE-SM SIG SCHOTTKY	28480	1901-0518
A6CR2	1902-0951	5	10	DIODE-ZNR 5.1V 5% DO-35 PD=.4W TC=+.035%	28480	1902-0951
A6CR3	1902-0951	5		DIODE-ZNR 5.1V 5% DO-35 PD=.4W TC=+.035%	28480	1902-0951
A6CR4	1901-0518	8		DIODE-SM SIG SCHOTTKY	28480	1901-0518
A6CR5	1901-0518	8		DIODE-SM SIG SCHOTTKY	28480	1901-0518
A6CR6	1902-0951	5		DIODE-ZNR 5.1V 5% DO-35 PD=.4W TC=+.035%	28480	1902-0951
A6CR7	1902-0951	5		DIODE-ZNR 5.1V 5% DO-35 PD=.4W TC=+.035%	28480	1902-0951
A6CR8	1902-0951	5		DIODE-ZNR 5.1V 5% DO-35 PD=.4W TC=+.035%	28480	1902-0951
A6CR9	1902-0951	5		DIODE-ZNR 5.1V 5% DO-35 PD=.4W TC=+.035%	28480	1902-0951
A6CR10	1902-0951	5		DIODE-ZNR 5.1V 5% DO-35 PD=.4W TC=+.035%	28480	1902-0951
A6CR11	1902-0951	5		DIODE-ZNR 5.1V 5% DO-35 PD=.4W TC=+.035%	28480	1902-0951
A6CR12	1902-0951	5		DIODE-ZNR 5.1V 5% DO-35 PD=.4W TC=+.035%	28480	1902-0951
A6CR13	1902-0951	5		DIODE-ZNR 5.1V 5% DO-35 PD=.4W TC=+.035%	28480	1902-0951
A6DS1	1990-0665	3	9	LED-LAMP LUM-INT=1MCD IF=20MA-MAX BVR=5V	28480	1990-0665
A6DS2	1990-0665	3		LED-LAMP LUM-INT=1MCD IF=20MA-MAX BVR=5V	28480	1990-0665
A6DS3	1990-0665	3		LED-LAMP LUM-INT=1MCD IF=20MA-MAX BVR=5V	28480	1990-0665
A6DS4	1990-0665	3		LED-LAMP LUM-INT=1MCD IF=20MA-MAX BVR=5V	28480	1990-0665
A6DS5	1990-0665	3		LED-LAMP LUM-INT=1MCD IF=20MA-MAX BVR=5V	28480	1990-0665
A6DS6	1990-0665	3		LED-LAMP LUM-INT=1MCD IF=20MA-MAX BVR=5V	28480	1990-0665
A6DS7	1990-0665	3		LED-LAMP LUM-INT=1MCD IF=20MA-MAX BVR=5V	28480	1990-0665
A6DS8	1990-0665	3		LED-LAMP LUM-INT=1MCD IF=20MA-MAX BVR=5V	28480	1990-0665
A6DS9	1990-0665	3		LED-LAMP LUM-INT=1MCD IF=20MA-MAX BVR=5V	28480	1990-0665
A6F1	2110-0592	2	1	FUSE 4A 125V NTD .281X.093	28480	2110-0592
A6J1	1200-0567	1	30	SOCKET-IC 28-CONT DIP DIP-SLDR	28480	1200-0567
A6J2	1200-0567	1		SOCKET-IC 28-CONT DIP DIP-SLDR	28480	1200-0567
A6J3	1200-0567	1		SOCKET-IC 28-CONT DIP DIP-SLDR	28480	1200-0567
A6J4	1200-0567	1		SOCKET-IC 28-CONT DIP DIP-SLDR	28480	1200-0567
A6J5	1200-0567	1		SOCKET-IC 28-CONT DIP DIP-SLDR	28480	1200-0567
A6J6	1200-0567	1		SOCKET-IC 28-CONT DIP DIP-SLDR	28480	1200-0567
A6J7	1200-0567	1		SOCKET-IC 28-CONT DIP DIP-SLDR	28480	1200-0567
A6J8	1200-0567	1		SOCKET-IC 28-CONT DIP DIP-SLDR	28480	1200-0567
A6J9	1200-0567	1		SOCKET-IC 28-CONT DIP DIP-SLDR	28480	1200-0567
A6J10	1200-0567	1		SOCKET-IC 28-CONT DIP DIP-SLDR	28480	1200-0567
A6J11	1200-0567	1		SOCKET-IC 28-CONT DIP DIP-SLDR	28480	1200-0567
A6J12	1200-0567	1		SOCKET-IC 28-CONT DIP DIP-SLDR	28480	1200-0567
A6J13	1200-0567	1		SOCKET-IC 28-CONT DIP DIP-SLDR	28480	1200-0567
A6J14	1200-0567	1		SOCKET-IC 28-CONT DIP DIP-SLDR	28480	1200-0567
A6J15	1200-0567	1		SOCKET-IC 28-CONT DIP DIP-SLDR	28480	1200-0567
A6J16	1200-0567	1		SOCKET-IC 28-CONT DIP DIP-SLDR	28480	1200-0567

See introduction to this section for ordering information.
* Indicates factory selected value.

Table 6-3. Replaceable Parts (continued)

Reference Designator	HP Part Number	C D	Qty.	Description	Mfr Code	Mfr Part Number
A6J17	1200-0567	1		SOCKET-IC 28-CONT DIP DIP-SLDR	28480	1200-0567
A6J18	1200-0567	1		SOCKET-IC 28-CONT DIP DIP-SLDR	28480	1200-0567
A6J19	1200-0567	1		SOCKET-IC 28-CONT DIP DIP-SLDR	28480	1200-0567
A6J20	1200-0567	1		SOCKET-IC 28-CONT DIP DIP-SLDR	28480	1200-0567
A6J21	1200-0567	1		SOCKET-IC 28-CONT DIP DIP-SLDR	28480	1200-0567
A6J22	1200-0567	1		SOCKET-IC 28-CONT DIP DIP-SLDR	28480	1200-0567
A6J23	1200-0567	1		SOCKET-IC 28-CONT DIP DIP-SLDR	28480	1200-0567
A6J24	1200-0567	1		SOCKET-IC 28-CONT DIP DIP-SLDR	28480	1200-0567
A6J25	1200-0944	8	1	SOCKET-IC 64-CONT DIP-SLDR	28480	1200-0944
A6J26	1200-0567	1		SOCKET-IC 28-CONT DIP DIP-SLDR	28480	1200-0567
A6J27	1200-0567	1		SOCKET-IC 28-CONT DIP DIP-SLDR	28480	1200-0567
A6J28	1200-0567	1		SOCKET-IC 28-CONT DIP DIP-SLDR	28480	1200-0567
A6J29	1200-0567	1		SOCKET-IC 28-CONT DIP DIP-SLDR	28480	1200-0567
A6J30	1200-0567	1		SOCKET-IC 28-CONT DIP DIP-SLDR	28480	1200-0567
A6J31	1200-0567	1		SOCKET-IC 28-CONT DIP DIP-SLDR	28480	1200-0567
A6L1	9170-0847	3	4	CORE-SHIELDING BEAD	02114	56-590-65/3B
A6Q1	1853-0281	9	2	TRANSISTOR PNP 2N2907A SI TO-18 PD=400MW	04713	2N2907A
A6Q2				NOT ASSIGNED		
A6Q3	1853-0281	9		TRANSISTOR PNP 2N2907A SI TO-18 PD=400MW	04713	2N2907A
A6Q4	1854-0810	2	1	TRANSISTOR NPN SI PD=625MW FT=200MHZ	28480	1854-0810
A6R1	1810-0279	5	10	NETWORK-RES 10-SIP4.7K OHM X 9	01121	210A472
A6R2	1810-0279	5		NETWORK-RES 10-SIP4.7K OHM X 9	01121	210A472
A6R3	1810-0273	9	1	NETWORK-RES 10-SIP470.0 OHM X 9	01121	210A471
A6R4	1810-0279	5		NETWORK-RES 10-SIP4.7K OHM X 9	01121	210A472
A6R5	1810-0279	5		NETWORK-RES 10-SIP4.7K OHM X 9	01121	210A472
A6R6	1810-0279	5		NETWORK-RES 10-SIP4.7K OHM X 9	01121	210A472
A6R7	0698-3155	1	4	RESISTOR 4.64K 1% .125W F TC=0+-100	24546	C4-1/8-T0-4641-F
A6R8	0757-0280	3	4	RESISTOR 1K 1% .125W F TC=0+-100	24546	C4-1/8-T0-1001-F
A6R9	0698-3155	1		RESISTOR 4.64K 1% .125W F TC=0+-100	24546	C4-1/8-T0-4641-F
A6R10	0698-3155	1		RESISTOR 4.64K 1% .125W F TC=0+-100	24546	C4-1/8-T0-4641-F
A6R11	1810-0279	5		NETWORK-RES 10-SIP4.7K OHM X 9	01121	210A472
A6R12	1810-0279	5		NETWORK-RES 10-SIP4.7K OHM X 9	01121	210A472
A6R13	1810-0279	5		NETWORK-RES 10-SIP4.7K OHM X 9	01121	210A472
A6R14				NOT ASSIGNED		
A6R15	0698-3155	1		RESISTOR 4.64K 1% .125W F TC=0+-100	24546	C4-1/8-T0-4641-F
A6R15	0757-0280	3		RESISTOR 1K 1% .125W F TC=0+-100	24546	C4-1/8-T0-1001-F
A6R16	0757-0442	9	5	RESISTOR 10K 1% .125W F TC=0+-100	24546	C4-1/8-T0-1002-F
A6R17				NOT ASSIGNED		
A6R18	0698-3155	1		RESISTOR 4.64K 1% .125W		
A6R19	0757-0346	2	1	RESISTOR 10 1% .125W F TC=0+-100	24546	C4-1/8-T0-10R0-F
A6R20	0698-3441	8	3	RESISTOR 215 1% .125W F TC=0+-100	24546	C4-1/8-T0-215R-F
A6R21	0757-0442	9		RESISTOR 10K 1% .125W F TC=0+-100	24546	C4-1/8-T0-1002-F
A6R22	0698-3441	8		RESISTOR 215 1% .125W F TC=0+-100	24546	C4-1/8-T0-215R-F
A6R23	0757-0442	9		RESISTOR 10K 1% .125W F TC=0+-100	24546	C4-1/8-T0-1002-F
A6R24	0757-0442	9		RESISTOR 10K 1% .125W F TC=0+-100	24546	C4-1/8-T0-1002-F
A6R25	0698-3162	0	1	RESISTOR 46.4K 1% .125W F TC=0+-100	24546	C4-1/8-T0-4642-F
A6R26	0757-0280	3		RESISTOR 1K 1% .125W F TC=0+-100	24546	C4-1/8-T0-1001-F
A6R27	0757-0442	9		RESISTOR 10K 1% .125W F TC=0+-100	24546	C4-1/8-T0-1002-F
A6R28	0757-0280	3		RESISTOR 1K 1% .125W F TC=0+-100	24546	C4-1/8-T0-1001-F

See introduction to this section for ordering information.
 * Indicates factory selected value.

Table 6-3. Replaceable Parts (continued)

Reference Designator	HP Part Number	C D	Qty.	Description	Mfr Code	Mfr Part Number
A6R29	1810-0279	5		NETWORK-RES 10-SIP4.7K OHM X 9	01121	210A472
A6R30	1810-0269	3	3	NETWORK-RES 9-SIP10.0K OHM X 8	28480	1810-0269
A6R31	1810-0269	3		NETWORK-RES 9-SIP10.0K OHM X 8	28480	1810-0269
A6R32	1810-0279	5		NETWORK-RES 10-SIP4.7K OHM X 9	01121	210A472
A6R33	0698-3441	8		RESISTOR 215 1% .125W F TC=0+-100	24546	C4-1/8-T0-215R-F
A6R34	0698-3430	5	1	RESISTOR 21.5 1% .125W F TC=0+-100	03888	PME55-1/8-T0-21R5-F
A6R35	1810-0325	2	1	NETWORK-RES 16-DIP150.0 OHM X 8	01121	316B151
A6R36	1810-0269	3		NETWORK-RES 9-SIP10.0K OHM X 8	28480	1810-0269
A6R37	1810-0338	7	1	NETWORK-RES 16-DIP100.0 OHM X 8	11236	761-3-R100
A6SW1	3101-2831	8	3	SWITCH 8P	28480	3101-2831
A6SW2	3101-2832	9	1	SWITCH 4P	28480	3101-2832
A6U1	1820-2757	9	1	IC FF TTL ALS D-TYPE POS-EDGE-TRIG OCTL	01295	SN74ALS574N
A6U2	1820-2711	5	3	IC DRVR TTL LS LINE DRVR OCTL	01295	SN74LS541N
A6U3	1820-2711	5		IC DRVR TTL LS LINE DRVR OCTL	01295	SN74LS541N
A6U4	04194-85601	2	1	ROM PROGRAMMED	28480	04194-85601
A6U5	04194-85603	4	1	ROM PROGRAMMED	28480	04194-85603
A6U6	04194-85605	6	1	ROM PROGRAMMED	28480	04194-85605
A6U7	04194-85607	8	1	ROM PROGRAMMED	28480	04194-85607
A6U8	04194-85609	0	1	ROM PROGRAMMED	28480	04194-85609
A6U9	04194-85611	4	1	ROM PROGRAMMED	28480	04194-85611
A6U10	04194-85613	6	1	ROM PROGRAMMED	28480	04194-85613
A6U11	04194-85615	8	1	ROM PROGRAMMED	28480	04194-85615
A6U12	04194-85617	0	1	ROM PROGRAMMED	28480	04194-85617
A6U13				NOT ASSIGNED		
A6U14				NOT ASSIGNED		
A6U15				NOT ASSIGNED		
A6U16	1820-3100	8	4	IC DCDR TTL ALS BIN 3-TO-8-LINE 3-INP	28480	1820-3100
A6U17	1820-3100	8		IC DCDR TTL ALS BIN 3-TO-8-LINE 3-INP	28480	1820-3100
A6U18	1820-2634	1	2	IC INV TTL ALS HEX	01295	SN74ALS04N
A6U19	1820-2488	3	2	IC FF TTL ALS D-TYPE POS-EDGE TRIG	01295	SN74ALS74N
A6U20	04194-85602	3	1	ROM PROGRAMMED	28480	04194-85602
A6U21	04194-85604	5	1	ROM PROGRAMMED	28480	04194-85604
A6U22	04194-85606	7	1	ROM PROGRAMMED	28480	04194-85606
A6U23	04194-85608	9	1	ROM PROGRAMMED	28480	04194-85608
A6U24	04194-85610	3	1	ROM PROGRAMMED	28480	04194-85610
A6U25	04194-85612	5	1	ROM PROGRAMMED	28480	04194-85612
A6U26	04194-85614	7	1	ROM PROGRAMMED	28480	04194-85614
A6U27	04194-85616	9	1	ROM PROGRAMMED	28480	04194-85616
A6U28	04194-85618	1	1	ROM PROGRAMMED	28480	04194-85618
A6U29				NOT ASSIGNED		
A6U30				NOT ASSIGNED		
A6U31				NOT ASSIGNED		
A6U32	1820-2873	0	1	IC-UPD8253-5	28480	1820-2873
A6U33	1820-2656	7	4	IC GATE TTL ALS NAND QUAD 2-INP	01295	SN74ALS00N
A6U34	1820-3320	4	1	IC-16BIT,10MHZ,CERAMIC MPU W/32 BIT DATA	28480	1820-3320
A6U35	1820-2774	0	2	IC GATE TTL ALS NAND DUAL 4-INP	01295	SN74ALS20N
A6U36	1820-3376	0	2	IC INV TTL ALS HEX	28480	1820-3376
A6U37	1820-3121	3	8	IC TRANSCEIVER TTL ALS BUS OCTL	28480	1820-3121
A6U38	1820-3121	3		IC TRANSCEIVER TTL ALS BUS OCTL	28480	1820-3121

See introduction to this section for ordering information.
 * Indicates factory selected value.

Table 6-3. Replaceable Parts (continued)

Reference Designator	HP Part Number	C D	Qty.	Description	Mfr Code	Mfr Part Number
A6U39	1820-3220	3	1	IC DCDR TTL F BIN 2-TO-4-LINE DUAL	28480	1820-3220
A6U40	1820-3376	0		IC INV TTL ALS HEX	28480	1820-3376
A6U41	1820-2096	9	1	IC CNTR TTL LS BIN DUAL 4-BIT	01295	SN74LS393N
A6U42	1820-2922	0	1	IC GATE CMOS/74HC NAND QUAD 2-INP	28480	1820-2922
A6U43	1818-3183	2	6	IC CMOS 65536 (64K) STAT RAM 150-NS 3-S	28480	1818-3183
A6U44	1818-3183	2		IC CMOS 65536 (64K) STAT RAM 150-NS 3-S	28480	1818-3183
A6U45	1818-3183	2		IC CMOS 65536 (64K) STAT RAM 150-NS 3-S	28480	1818-3183
A6U46	1818-3183	2		IC CMOS 65536 (64K) STAT RAM 150-NS 3-S	28480	1818-3183
A6U47	1818-3183	2		IC CMOS 65536 (64K) STAT RAM 150-NS 3-S	28480	1818-3183
A6U48	1818-3183	2		IC CMOS 65536 (64K) STAT RAM 150-NS 3-S	28480	1818-3183
A6U49	1820-2657	8	1	IC GATE TTL ALS OR QUAD 2-INP	01295	SN74ALS32N
A6U50	1820-1851	2	1	IC ENCDR TTL LS	01295	SN74LS148N
A6U51	1820-3480	7	1	IC DRVR TTL ALS AND QUAD 2-INP	28480	1820-3480
A6U52	1820-3121	3		IC TRANSCEIVER TTL ALS BUS OCTL	28480	1820-3121
A6U53	1820-3121	3		IC TRANSCEIVER TTL ALS BUS OCTL	28480	1820-3121
A6U54	1820-3121	3		IC TRANSCEIVER TTL ALS BUS OCTL	28480	1820-3121
A6U55	1820-3100	8		IC DCDR TTL ALS BIN 3-TO-8-LINE 3-INP	28480	1820-3100
A6U56	1820-3100	8		IC DCDR TTL ALS BIN 3-TO-8-LINE 3-INP	28480	1820-3100
A6U57	1820-2488	3		IC FF TTL ALS D-TYPE POS-EDGE-TRIG	01295	SN74ALS74N
A6U58	1820-3145	1	2	IC DRVR TTL ALS BUS OCTL	28480	1820-3145
A6U59	1820-1245	8	1	IC DCDR TTL LS 2-TO-4-LINE DUAL 2-INP	01295	SN74LS155N
A6U60	1826-1273	4	1	IC V RGLTR-OV-V-SEN 8-DIP-P PKG	28480	1826-1273
A6U61	1820-2774	0		IC GATE TTL ALS NAND DUAL 4-INP	01295	SN74ALS20N
A6U62	1820-3318	0	1	IC FF TTL ALS D-TYPE POS-EDGE-TRIG COM	28480	1820-3318
A6U63	1820-2634	1		IC INV TTL ALS HEX	01295	SN74ALS04N
A6U64	1820-3121	3		IC TRANSCEIVER TTL ALS BUS OCTL	28480	1820-3121
A6U65	1820-3121	3		IC TRANSCEIVER TTL ALS BUS OCTL	28480	1820-3121
A6U66	1820-3121	3		IC TRANSCEIVER TTL ALS BUS OCTL	28480	1820-3121
A6U67	1820-2777	3	1	IC CNTR TTL ALS BIN SYNCHRO	01295	SN74ALS161N
A6U68	1820-2656	7		IC GATE TTL ALS NAND QUAD 2-INP	01295	SN74ALS00N
A6U69	1813-0463	5	1	KXO-01 20.0MHZ	28480	1813-0463
A6U70	1820-2656	7		IC GATE TTL ALS NAND QUAD 2-INP	01295	SN74ALS00N
A6U71	1820-2656	7		IC GATE TTL ALS NAND QUAD 2-INP	01295	SN74ALS00N
A6U72	1820-2635	2	1	IC GATE TTL ALS AND QUAD 2-INP	01295	SN74ALS08N
A6U73	1820-1469	8	1	IC FF TTL LS J-K NEG-EDGE-TRIG CLEAR	01295	SN74LS107AN
A6U74	1820-1416	5	1	IC SCHMITT-TRIG TTL LS INV HEX 1-INP	01295	SN74LS14N
A6U75	1820-1858	9	1	IC FF TTL LS D-TYPE OCTL	01295	SN74LS377N
A6U76	1820-2711	5		IC DRVR TTL LS LINE DRVR OCTL	01295	SN74LS541N
A6U77	1820-3145	1		IC DRVR TTL ALS BUS OCTL	28480	1820-3145
A6U78	04194-80003	8	1	AM PAL16R4ADC	28480	04194-80003
A6W1	1251-4822	6	4	CONNECTOR 3-PIN M POST TYPE	28480	1251-4822
A6W2	1251-4822	6		CONNECTOR 3-PIN M POST TYPE	28480	1251-4822
A6W3				NOT ASSIGNED		
A6W4				NOT ASSIGNED		
A6W5	1251-4822	6		CONNECTOR 3-PIN M POST TYPE	28480	1251-4822
A6W6	1251-4822	6		CONNECTOR 3-PIN M POST TYPE	28480	1251-4822
A6XL	1252-0720	7	2	CONN DIN 96PF	28480	1252-0720
A6XR	1252-0720	7		CONN DIN 96PF	28480	1252-0720
	4040-0748	3	1	EXTR-PC BD BLK POLYC .062-BD-THKNS	28480	4040-0748

See introduction to this section for ordering information.
* Indicates factory selected value.

Table 6-3. Replaceable Parts (continued)

Reference Designator	HP Part Number	C D	Qty.	Description	Mfr Code	Mfr Part Number
	4040-0754	1	1	EXTR-PC BD BLU POLYC .062-BD-THKNS	28480	4040-0754
	8150-3490	5	1	WIRE	28480	8150-3490

See introduction to this section for ordering information.
 * Indicates factory selected value.

Table 6-3. Replaceable Parts (continued)

Reference Designator	HP Part Number	C D	Qty.	Description	Mfr Code	Mfr Part Number
A7	04194-66507	7	1	GDC/RAM BOARD ASSEMBLY	28480	04194-66507
A7C1	0160-4835	7	52	CAPACITOR-FXD .1UF +-10% 50VDC CER	28480	0160-4835
A7C2	0160-4835	7		CAPACITOR-FXD .1UF +-10% 50VDC CER	28480	0160-4835
A7C3	0160-4835	7		CAPACITOR-FXD .1UF +-10% 50VDC CER	28480	0160-4835
A7C4	0160-4835	7		CAPACITOR-FXD .1UF +-10% 50VDC CER	28480	0160-4835
A7C5	0160-4835	7		CAPACITOR-FXD .1UF +-10% 50VDC CER	28480	0160-4835
A7C6	0160-4822	2	15	CAPACITOR-FXD 1000PF +-5% 100VDC CER	28480	0160-4822
A7C7	0160-5945	2	2	CAPACITOR-FXD 0.01UF	28480	0160-5945
A7C8	0160-4832	4	21	CAPACITOR-FXD .01UF +-10% 100VDC CER	28480	0160-4832
A7C9	0160-4832	4		CAPACITOR-FXD .01UF +-10% 100VDC CER	28480	0160-4832
A7C10	0160-4822	2		CAPACITOR-FXD 1000PF +-5% 100VDC CER	28480	0160-4822
A7C11	0160-4822	2		CAPACITOR-FXD 1000PF +-5% 100VDC CER	28480	0160-4822
A7C12	0160-4822	2		CAPACITOR-FXD 1000PF +-5% 100VDC CER	28480	0160-4822
A7C13	0160-4822	2		CAPACITOR-FXD 1000PF +-5% 100VDC CER	28480	0160-4822
A7C14	0160-5945	2		CAPACITOR-FXD 0.01UF	28480	0160-5945
A7C15	0160-4822	2		CAPACITOR-FXD 1000PF +-5% 100VDC CER	28480	0160-4822
A7C16	0160-4835	7		CAPACITOR-FXD .1UF +-10% 50VDC CER	28480	0160-4835
A7C17	0160-4835	7		CAPACITOR-FXD .1UF +-10% 50VDC CER	28480	0160-4835
A7C18	0160-4835	7		CAPACITOR-FXD .1UF +-10% 50VDC CER	28480	0160-4835
A7C19	0160-4835	7		CAPACITOR-FXD .1UF +-10% 50VDC CER	28480	0160-4835
A7C20	0160-4835	7		CAPACITOR-FXD .1UF +-10% 50VDC CER	28480	0160-4835
A7C21	0160-4835	7		CAPACITOR-FXD .1UF +-10% 50VDC CER	28480	0160-4835
A7C22	0160-4835	7		CAPACITOR-FXD .1UF +-10% 50VDC CER	28480	0160-4835
A7C23	0160-4835	7		CAPACITOR-FXD .1UF +-10% 50VDC CER	28480	0160-4835
A7C24	0160-4835	7		CAPACITOR-FXD .1UF +-10% 50VDC CER	28480	0160-4835
A7C25	0160-4835	7		CAPACITOR-FXD .1UF +-10% 50VDC CER	28480	0160-4835
A7C26	0160-4832	4		CAPACITOR-FXD .01UF +-10% 100VDC CER	28480	0160-4832
A7C27	0160-4822	2		CAPACITOR-FXD 1000PF +-5% 100VDC CER	28480	0160-4822
A7C28	0160-4822	2		CAPACITOR-FXD 1000PF +-5% 100VDC CER	28480	0160-4822
A7C29	0160-4832	4		CAPACITOR-FXD .01UF +-10% 100VDC CER	28480	0160-4832
A7C30	0160-4832	4		CAPACITOR-FXD .01UF +-10% 100VDC CER	28480	0160-4832
A7C31	0160-4832	4		CAPACITOR-FXD .01UF +-10% 100VDC CER	28480	0160-4832
A7C32	0160-4822	2		CAPACITOR-FXD 1000PF +-5% 100VDC CER	28480	0160-4822
A7C33	0160-4822	2		CAPACITOR-FXD 1000PF +-5% 100VDC CER	28480	0160-4822
A7C34	0160-4835	7		CAPACITOR-FXD .1UF +-10% 50VDC CER	28480	0160-4835
A7C35	0160-4835	7		CAPACITOR-FXD .1UF +-10% 50VDC CER	28480	0160-4835
A7C36	0160-4835	7		CAPACITOR-FXD .1UF +-10% 50VDC CER	28480	0160-4835
A7C37	0160-4835	7		CAPACITOR-FXD .1UF +-10% 50VDC CER	28480	0160-4835
A7C38	0160-4835	7		CAPACITOR-FXD .1UF +-10% 50VDC CER	28480	0160-4835
A7C39	0160-4835	7		CAPACITOR-FXD .1UF +-10% 50VDC CER	28480	0160-4835
A7C40	0160-4835	7		CAPACITOR-FXD .1UF +-10% 50VDC CER	28480	0160-4835
A7C41	0160-4835	7		CAPACITOR-FXD .1UF +-10% 50VDC CER	28480	0160-4835
A7C42	0160-4832	4		CAPACITOR-FXD .01UF +-10% 100VDC CER	28480	0160-4832
A7C43	0160-4832	4		CAPACITOR-FXD .01UF +-10% 100VDC CER	28480	0160-4832
A7C44	0160-4832	4		CAPACITOR-FXD .01UF +-10% 100VDC CER	28480	0160-4832
A7C45	0160-4832	4		CAPACITOR-FXD .01UF +-10% 100VDC CER	28480	0160-4832
A7C46	0160-4822	2		CAPACITOR-FXD 1000PF +-5% 100VDC CER	28480	0160-4822
A7C47	0160-4822	2		CAPACITOR-FXD 1000PF +-5% 100VDC CER	28480	0160-4822

See introduction to this section for ordering information.
 * Indicates factory selected value.

Table 6-3. Replaceable Parts (continued)

Reference Designator	HP Part Number	C D	Qty.	Description	Mfr Code	Mfr Part Number
A7C48	0160-4835	7		CAPACITOR-FXD .1UF +-10% 50VDC CER	28480	0160-4835
A7C49	0160-4835	7		CAPACITOR-FXD .1UF +-10% 50VDC CER	28480	0160-4835
A7C50	0160-4835	7		CAPACITOR-FXD .1UF +-10% 50VDC CER	28480	0160-4835
A7C51	0160-4835	7		CAPACITOR-FXD .1UF +-10% 50VDC CER	28480	0160-4835
A7C52	0160-4832	4		CAPACITOR-FXD .01UF +-10% 100VDC CER	28480	0160-4832
A7C53	0160-4832	4		CAPACITOR-FXD .01UF +-10% 100VDC CER	28480	0160-4832
A7C54	0160-4835	7		CAPACITOR-FXD .1UF +-10% 50VDC CER	28480	0160-4835
A7C55	0160-4835	7		CAPACITOR-FXD .1UF +-10% 50VDC CER	28480	0160-4835
A7C56	0160-4835	7		CAPACITOR-FXD .1UF +-10% 50VDC CER	28480	0160-4835
A7C57	0160-4835	7		CAPACITOR-FXD .1UF +-10% 50VDC CER	28480	0160-4835
A7C58	0160-4835	7		CAPACITOR-FXD .1UF +-10% 50VDC CER	28480	0160-4835
A7C59	0160-4835	7		CAPACITOR-FXD .1UF +-10% 50VDC CER	28480	0160-4835
A7C60	0160-4835	7		CAPACITOR-FXD .1UF +-10% 50VDC CER	28480	0160-4835
A7C61	0160-4835	7		CAPACITOR-FXD .1UF +-10% 50VDC CER	28480	0160-4835
A7C62	0160-4835	7		CAPACITOR-FXD .1UF +-10% 50VDC CER	28480	0160-4835
A7C63	0160-4835	7		CAPACITOR-FXD .1UF +-10% 50VDC CER	28480	0160-4835
A7C64	0160-4835	7		CAPACITOR-FXD .1UF +-10% 50VDC CER	28480	0160-4835
A7C65	0160-4835	7		CAPACITOR-FXD .1UF +-10% 50VDC CER	28480	0160-4835
A7C66	0160-4835	7		CAPACITOR-FXD .1UF +-10% 50VDC CER	28480	0160-4835
A7C67	0160-4835	7		CAPACITOR-FXD .1UF +-10% 50VDC CER	28480	0160-4835
A7C68	0180-0291	3	1	CAPACITOR-FXD 1UF 35VDC TA	28480	0180-0291
A7C69	0160-4813	1	2	CAPACITOR-FXD 180PF +-5% 100VDC CER	28480	0160-4813
A7C70	0160-4813	1		CAPACITOR-FXD 180PF +-5% 100VDC CER	28480	0160-4813
A7C71	0160-4832	4		CAPACITOR-FXD .01UF +-10% 100VDC CER	28480	0160-4832
A7C72	0160-4832	4		CAPACITOR-FXD .01UF +-10% 100VDC CER	28480	0160-4832
A7C73	0160-4822	2		CAPACITOR-FXD 1000PF +-5% 100VDC CER	28480	0160-4822
A7C74	0160-4835	7		CAPACITOR-FXD .1UF +-10% 50VDC CER	28480	0160-4835
A7C75	0160-4835	7		CAPACITOR-FXD .1UF +-10% 50VDC CER	28480	0160-4835
A7C76	0160-4835	7		CAPACITOR-FXD .1UF +-10% 50VDC CER	28480	0160-4835
A7C77	0160-4835	7		CAPACITOR-FXD .1UF +-10% 50VDC CER	28480	0160-4835
A7C78	0160-4835	7		CAPACITOR-FXD .1UF +-10% 50VDC CER	28480	0160-4835
A7C79	0160-4835	7		CAPACITOR-FXD .1UF +-10% 50VDC CER	28480	0160-4835
A7C80	0160-4835	7		CAPACITOR-FXD .1UF +-10% 50VDC CER	28480	0160-4835
A7C81	0160-4835	7		CAPACITOR-FXD .1UF +-10% 50VDC CER	28480	0160-4835
A7C82	0160-4835	7		CAPACITOR-FXD .1UF +-10% 50VDC CER	28480	0160-4835
A7C83	0160-4835	7		CAPACITOR-FXD .1UF +-10% 50VDC CER	28480	0160-4835
A7C84	0160-4835	7		CAPACITOR-FXD .1UF +-10% 50VDC CER	28480	0160-4835
A7C85	0160-4832	4		CAPACITOR-FXD .01UF +-10% 100VDC CER	28480	0160-4832
A7C86	0160-4832	4		CAPACITOR-FXD .01UF +-10% 100VDC CER	28480	0160-4832
A7C87	0160-4832	4		CAPACITOR-FXD .01UF +-10% 100VDC CER	28480	0160-4832
A7C88	0160-4832	4		CAPACITOR-FXD .01UF +-10% 100VDC CER	28480	0160-4832
A7C89	0160-4832	4		CAPACITOR-FXD .01UF +-10% 100VDC CER	28480	0160-4832
A7C90	0160-4822	2		CAPACITOR-FXD 1000PF +-5% 100VDC CER	28480	0160-4822
A7C91	0160-4822	2		CAPACITOR-FXD 1000PF +-5% 100VDC CER	28480	0160-4822
A7C92	0160-4832	4		CAPACITOR-FXD .01UF +-10% 100VDC CER	28480	0160-4832
A7C93	0160-4832	4		CAPACITOR-FXD .01UF +-10% 100VDC CER	28480	0160-4832
A7C94	0180-3217	9	2	CAPACITOR-FXD 470UF	28480	0180-3217
A7C95	0180-3217	9		CAPACITOR-FXD 470UF	28480	0180-3217
A7CR1	1901-0518	8	4	DIODE-SM SIG SCHOTTKY	28480	1901-0518

See introduction to this section for ordering information.
 * Indicates factory selected value.

Table 6-3. Replaceable Parts (continued)

Reference Designator	HP Part Number	C D	Qty.	Description	Mfr Code	Mfr Part Number
A7CR2	1901-0518	8		DIODE-SM SIG SCHOTTKY	28480	1901-0518
A7CR3	1901-0518	8		DIODE-SM SIG SCHOTTKY	28480	1901-0518
A7CR4	1901-0518	8		DIODE-SM SIG SCHOTTKY	28480	1901-0518
A7F1	2110-0592	2	1	FUSE 4A 125V NTD .281X.093	28480	2110-0592
A7J1	1200-0654	7	2	SOCKET-IC 40-CONT DIP DIP-SLDR	28480	1200-0654
A7J2	1200-0654	7		SOCKET-IC 40-CONT DIP DIP-SLDR	28480	1200-0654
A7L1	9170-0847	3	4	CORE-SHIELDING BEAD	02114	56-590-65/3B
A7R1	0698-3430	5	4	RESISTOR 21.5 1% .125W F TC=0+-100	03888	PME55-1/8-T0-21R5-F
A7R2	0698-3430	5		RESISTOR 21.5 1% .125W F TC=0+-100	03888	PME55-1/8-T0-21R5-F
A7R3	0698-3155	1	4	RESISTOR 4.64K 1% .125W F TC=0+-100	24546	C4-1/8-T0-4641-F
A7R4	0698-3155	1		RESISTOR 4.64K 1% .125W F TC=0+-100	24546	C4-1/8-T0-4641-F
A7R5	0698-3155	1		RESISTOR 4.64K 1% .125W F TC=0+-100	24546	C4-1/8-T0-4641-F
A7R6	1810-0279	5	19	NETWORK-RES 10-SIP4.7K OHM X 9	01121	210A472
A7R7	1810-0279	5		NETWORK-RES 10-SIP4.7K OHM X 9	01121	210A472
A7R8	1810-0279	5		NETWORK-RES 10-SIP4.7K OHM X 9	01121	210A472
A7R9	1810-0279	5		NETWORK-RES 10-SIP4.7K OHM X 9	01121	210A472
A7R10	1810-0279	5		NETWORK-RES 10-SIP4.7K OHM X 9	01121	210A472
A7R11	1810-0536	7	3	NETWORK-RES 16-DIP27.0 OHM X 8	28480	1810-0536
A7R12	1810-0279	5		NETWORK-RES 10-SIP4.7K OHM X 9	01121	210A472
A7R13	1810-0279	5		NETWORK-RES 10-SIP4.7K OHM X 9	01121	210A472
A7R14	1810-0279	5		NETWORK-RES 10-SIP4.7K OHM X 9	01121	210A472
A7R15	1810-0279	5		NETWORK-RES 10-SIP4.7K OHM X 9	01121	210A472
A7R16	1810-0279	5		NETWORK-RES 10-SIP4.7K OHM X 9	01121	210A472
A7R17	1810-0279	5		NETWORK-RES 10-SIP4.7K OHM X 9	01121	210A472
A7R18	1810-0536	7		NETWORK-RES 16-DIP27.0 OHM X 8	28480	1810-0536
A7R19	1810-0536	7		NETWORK-RES 16-DIP27.0 OHM X 8	28480	1810-0536
A7R20	0698-3430	5		RESISTOR 21.5 1% .125W F TC=0+-100	03888	PME55-1/8-T0-21R5-F
A7R21	0757-0439	4	1	RESISTOR 6.81K 1% .125W F TC=0+-100	24546	C4-1/8-T0-6811-F
A7R22	0698-3150	6	1	RESISTOR 2.37K 1% .125W F TC=0+-100	24546	C4-1/8-T0-2371-F
A7R23	0698-3152	8	1	RESISTOR 3.48K 1% .125W F TC=0+-100	24546	C4-1/8-T0-3481-F
A7R24	0698-3155	1		RESISTOR 4.64K 1% .125W F TC=0+-100	24546	C4-1/8-T0-4641-F
A7R25	1810-0279	5		NETWORK-RES 10-SIP4.7K OHM X 9	01121	210A472
A7R26	1810-0279	5		NETWORK-RES 10-SIP4.7K OHM X 9	01121	210A472
A7R27	1810-0279	5		NETWORK-RES 10-SIP4.7K OHM X 9	01121	210A472
A7R28	1810-0279	5		NETWORK-RES 10-SIP4.7K OHM X 9	01121	210A472
A7R29	1810-0279	5		NETWORK-RES 10-SIP4.7K OHM X 9	01121	210A472
A7R30	1810-0279	5		NETWORK-RES 10-SIP4.7K OHM X 9	01121	210A472
A7R31	1810-0279	5		NETWORK-RES 10-SIP4.7K OHM X 9	01121	210A472
A7R32	1810-0279	5		NETWORK-RES 10-SIP4.7K OHM X 9	01121	210A472
A7R33	0698-3430	5		RESISTOR 21.5 1% .125W F TC=0+-100	03888	PME55-1/8-T0-21R5-F
A7U1	1818-3308	3	16	IC NMOS 256K DYN RAM	28480	1818-3308
A7U2				NOT ASSIGNED		
A7U3	1818-3308	3		IC NMOS 256K DYN RAM	28480	1818-3308
A7U4				NOT ASSIGNED		
A7U5				NOT ASSIGNED		
A7U6	1820-2690	9	2	IC GATE TTL F OR QUAD 2-INP	07263	74F32PC
A7U7	1820-2696	5	1	IC FF TTL F D-TYPE POS-EDGE-TRIG COM CLK	07263	74F175PC
A7U8	1820-3100	8	1	IC DCDR TTL ALS BIN 3-TO-8-LINE 3-INP	28480	1820-3100
A7U9	1820-2657	8	5	IC GATE TTL ALS OR QUAD 2-INP	01295	SN74ALS32N

See introduction to this section for ordering information.
* Indicates factory selected value.

Table 6-3. Replaceable Parts (continued)

Reference Designator	HP Part Number	C D	Qty.	Description	Mfr Code	Mfr Part Number
A7U10	1820-2657	8		IC GATE TTL ALS OR QUAD 2-INP	01295	SN74ALS32N
A7U11	1820-2657	8		IC GATE TTL ALS OR QUAD 2-INP	01295	SN74ALS32N
A7U12	1820-2691	0	3	IC FF TTL F D-TYPE POS-EDGE-TRIG	07263	74F74PC
A7U13	1820-1433	6	2	IC SHF-RGTR TTL LS R-S SERIAL-IN PRL-OUT	01295	SN74LS164N
A7U14	1820-2690	9		IC GATE TTL F OR QUAD 2-INP	07263	74F32PC
A7U15	1820-1433	6		IC SHF-RGTR TTL LS R-S SERIAL-IN PRL-OUT	01295	SN74LS164N
A7U16	1820-3280	5	2	IC FF TTL F D-TYPE POS-EDGE-TRIG COM CLK	28480	1820-3280
A7U17	1820-2506	6	2	IC INV TTL F HEX	07263	74F04PC
A7U18	1820-3348	6	1	IC CNTR TTL F BIN SYNCHRO POS-EDGE-TRIG	28480	1820-3348
A7U19	1813-0464	6	1	KXO-01 25.2MHZ	28480	1813-0464
A7U20				NOT ASSIGNED		
A7U21				NOT ASSIGNED		
A7U22				NOT ASSIGNED		
A7U23				NOT ASSIGNED		
A7U24				NOT ASSIGNED		
A7U25				NOT ASSIGNED		
A7U26				NOT ASSIGNED		
A7U27				NOT ASSIGNED		
A7U28	1818-3308	3		IC NMOS 256K DYN RAM	28480	1818-3308
A7U29	1820-4020	3	1	IC UPD 7220A	28480	1820-4020
A7U30	1820-2724	0	4	IC-SN74ALS573	28480	1820-2724
A7U31	1820-2685	2	1	IC GATE TTL F NOR QUAD 2-INP	07263	74F02PC
A7U32	1820-2686	3	2	IC GATE TTL F AND QUAD 2-INP	07263	74F08PC
A7U33	1820-3280	5		IC FF TTL F D-TYPE POS-EDGE-TRIG COM CLK	28480	1820-3280
A7U34	1820-3121	3	22	IC TRANSCEIVER TTL ALS BUS OCTL	28480	1820-3121
A7U35	1820-3104	2	10	IC SHF-RGTR TTL ALS MULTI-MODE	28480	1820-3104
A7U36	1820-3121	3		IC TRANSCEIVER TTL ALS BUS OCTL	28480	1820-3121
A7U37	1820-3104	2		IC SHF-RGTR TTL ALS MULTI-MODE	28480	1820-3104
A7U38	1820-3121	3		IC TRANSCEIVER TTL ALS BUS OCTL	28480	1820-3121
A7U39	1820-3104	2		IC SHF-RGTR TTL ALS MULTI-MODE	28480	1820-3104
A7U40	1820-3121	3		IC TRANSCEIVER TTL ALS BUS OCTL	28480	1820-3121
A7U41	1820-3104	2		IC SHF-RGTR TTL ALS MULTI-MODE	28480	1820-3104
A7U42	1820-3121	3		IC TRANSCEIVER TTL ALS BUS OCTL	28480	1820-3121
A7U43	1820-3104	2		IC SHF-RGTR TTL ALS MULTI-MODE	28480	1820-3104
A7U44	1820-2691	0		IC FF TTL F D-TYPE POS-EDGE-TRIG	07263	74F74PC
A7U45	1820-2688	5	1	IC GATE TTL F AND TPL 3-INP	07263	74F11PC
A7U46	1818-3308	3		IC NMOS 256K DYN RAM	28480	1818-3308
A7U47	1818-3308	3		IC NMOS 256K DYN RAM	28480	1818-3308
A7U48	1818-3308	3		IC NMOS 256K DYN RAM	28480	1818-3308
A7U49	1818-3308	3		IC NMOS 256K DYN RAM	28480	1818-3308
A7U50	1818-3308	3		IC NMOS 256K DYN RAM	28480	1818-3308
A7U51	1818-3308	3		IC NMOS 256K DYN RAM	28480	1818-3308
A7U52	1818-3308	3		IC NMOS 256K DYN RAM	28480	1818-3308
A7U53	1818-3308	3		IC NMOS 256K DYN RAM	28480	1818-3308
A7U54	1820-3121	3		IC TRANSCEIVER TTL ALS BUS OCTL	28480	1820-3121
A7U55	1820-2724	0		IC SN74ALS573	28480	1820-2724
A7U56	1820-1445	0	1	IC LCH TTL LS 4-BIT	01295	SN74LS375N
A7U57	1820-3121	3		IC TRANSCEIVER TTL ALS BUS OCTL	28480	1820-3121
A7U58	1820-3104	2		IC SHF-RGTR TTL ALS MULTI-MODE	28480	1820-3104

See introduction to this section for ordering information.
 * Indicates factory selected value.

Table 6-3. Replaceable Parts (continued)

Reference Designator	HP Part Number	C D	Qty.	Description	Mfr Code	Mfr Part Number
A7U59	1820-3121	3		IC TRANSCEIVER TTL ALS BUS OCTL	28480	1820-3121
A7U60	1820-3104	2		IC SHF-RGTR TTL ALS MULTI-MODE	28480	1820-3104
A7U61	1820-3121	3		IC TRANSCEIVER TTL ALS BUS OCTL	28480	1820-3121
A7U62	1820-3104	2		IC SHF-RGTR TTL ALS MULTI-MODE	28480	1820-3104
A7U63	1820-3121	3		IC TRANSCEIVER TTL ALS BUS OCTL	28480	1820-3121
A7U64	1820-3104	2		IC SHF-RGTR TTL ALS MULTI-MODE	28480	1820-3104
A7U65	1820-3121	3		IC TRANSCEIVER TTL ALS BUS OCTL	28480	1820-3121
A7U66	1820-3104	2		IC SHF-RGTR TTL ALS MULTI-MODE	28480	1820-3104
A7U67	1820-2506	6		IC INV TTL F HEX	07263	74F04PC
A7U68	1820-2686	3		IC GATE TTL F AND QUAD 2-INP	07263	74F08PC
A7U69				NOT ASSIGNED		
A7U70				NOT ASSIGNED		
A7U71				NOT ASSIGNED		
A7U72				NOT ASSIGNED		
A7U73				NOT ASSIGNED		
A7U74	04194-80002	7	1	AM PAL16R6ADC	28480	04194-80002
A7U75	1820-4489	8	1	IC 74LS603A		74LS603A
A7U76	1820-1281	2	1	IC DCDR TTL LS 2-TO-4-LINE DUAL 2-INP	01295	SN74LS139N
A7U77	1820-2694	3	1	IC FF TTL F J-K NEG-EDGE-TRIG	07263	74F112PC
A7U78	1820-2656	7	1	IC GATE TTL ALS NAND QUAD 2-INP	01295	SN74ALS00N
A7U79	1820-2634	1	3	IC INV TTL ALS HEX	01295	SN74ALS04N
A7U80	1818-3214	0	20	IC TMS4416-15NL	28480	1818-3214
A7U81	1818-3214	0		IC TMS4416-15NL	28480	1818-3214
A7U82	1818-3214	0		IC TMS4416-15NL	28480	1818-3214
A7U83	1818-3214	0		IC TMS4416-15NL	28480	1818-3214
A7U84	1818-3214	0		IC TMS4416-15NL	28480	1818-3214
A7U85	1818-3214	0		IC TMS4416-15NL	28480	1818-3214
A7U86	1818-3214	0		IC TMS4416-15NL	28480	1818-3214
A7U87	1818-3214	0		IC TMS4416-15NL	28480	1818-3214
A7U88	1818-3214	0		IC TMS4416-15NL	28480	1818-3214
A7U89	1818-3214	0		IC TMS4416-15NL	28480	1818-3214
A7U90	1820-2657	8		IC GATE TTL ALS OR QUAD 2-INP	01295	SN74ALS32N
A7U91	1820-2634	1		IC INV TTL ALS HEX	01295	SN74ALS04N
A7U92	1818-3308	3		IC NMOS 256K DYN RAM	28480	1818-3308
A7U93	1818-3308	3		IC NMOS 256K DYN RAM	28480	1818-3308
A7U94	1818-3308	3		IC NMOS 256K DYN RAM	28480	1818-3308
A7U95	1818-3308	3		IC NMOS 256K DYN RAM	28480	1818-3308
A7U96	1818-3308	3		IC NMOS 256K DYN RAM	28480	1818-3059
A7U97	1820-1438	1	3	IC MUXR/DATA-SEL TTL LS 2-TO-1-LINE QUAD	01295	SN74LS257AN
A7U98	1820-1438	1		IC MUXR/DATA-SEL TTL LS 2-TO-1-LINE QUAD	01295	SN74LS257AN
A7U99	1820-1438	1		IC MUXR/DATA-SEL TTL LS 2-TO-1-LINE QUAD	01295	SN74LS257AN
A7U100	1820-2881	0	1	IC-SN74ALS27	28480	1820-2881
A7U101	1820-2657	8		IC GATE TTL ALS OR QUAD 2-INP	01295	SN74ALS32N
A7U102	1820-2691	0		IC FF TTL F D-TYPE POS-EDGE-TRIG	07263	74F74PC
A7U103	1816-1005	9	4	IC TTL S 64-BIT STAT RAM 30-NS 3-S	28480	1816-1005
A7U104	1816-1005	9		IC TTL S 64-BIT STAT RAM 30-NS 3-S	28480	1816-1005
A7U105	1818-3214	0		IC TMS4416-15NL	28480	1818-3214
A7U106	1818-3214	0		IC TMS4416-15NL	28480	1818-3214
A7U107	1818-3214	0		IC TMS4416-15NL	28480	1818-3214

See introduction to this section for ordering information.
 * Indicates factory selected value.

Table 6-3. Replaceable Parts (continued)

Reference Designator	HP Part Number	C D	Qty.	Description	Mfr Code	Mfr Part Number
A7U108	1818-3214	0		IC TMS4416-15NL	28480	1818-3214
A7U109	1818-3214	0		IC TMS4416-15NL	28480	1818-3214
A7U110	1818-3214	0		IC TMS4416-15NL	28480	1818-3214
A7U111	1818-3214	0		IC TMS4416-15NL	28480	1818-3214
A7U112	1818-3214	0		IC TMS4416-15NL	28480	1818-3214
A7U113	1818-3214	0		IC TMS4416-15NL	28480	1818-3214
A7U114	1818-3214	0		IC TMS4416-15NL	28480	1818-3214
A7U115	1820-2549	7	1	IC-8291A P HP1B	28480	1820-2549
A7U116	1820-2724	0		IC-SN74ALS573	28480	1820-2724
A7U117	1820-2724	0		IC-SN74ALS573	28480	1820-2724
A7U118	1820-2634	1		IC INV TTL ALS HEX	01295	SN74ALS04N
A7U119	1820-3121	3		IC TRANSCEIVER TTL ALS BUS OCTL	28480	1820-3121
A7U120	1820-3121	3		IC TRANSCEIVER TTL ALS BUS OCTL	28480	1820-3121
A7U121	1820-3121	3		IC TRANSCEIVER TTL ALS BUS OCTL	28480	1820-3121
A7U122	1820-3121	3		IC TRANSCEIVER TTL ALS BUS OCTL	28480	1820-3121
A7U123	1820-3121	3		IC TRANSCEIVER TTL ALS BUS OCTL	28480	1820-3121
A7U124	1820-3121	3		IC TRANSCEIVER TTL ALS BUS OCTL	28480	1820-3121
A7U125	1820-3121	3		IC TRANSCEIVER TTL ALS BUS OCTL	28480	1820-3121
A7U126	1820-3121	3		IC TRANSCEIVER TTL ALS BUS OCTL	28480	1820-3121
A7U127	1820-3121	3		IC TRANSCEIVER TTL ALS BUS OCTL	28480	1820-3121
A7U128	1820-3121	3		IC TRANSCEIVER TTL ALS BUS OCTL	28480	1820-3121
A7U129	1820-2711	5	1	IC DRVR TTL LS LINE DRVR OCTL	01295	SN74LS541M
A7U130	1820-2701	3	2	IC FF TTL F D-TYPE POS-EDGE-TRIG COM	07263	74F374PC
A7U131	1816-1005	9		IC TTL S 64-BIT STAT RAM 30-NS 3-S	28480	1816-1005
A7U132	1816-1005	9		IC TTL S 64-BIT STAT RAM 30-NS 3-S	28480	1816-1005
A7U133	1820-2701	3		IC FF TTL F D-TYPE POS-EDGE-TRIG COM	07263	74F374PC
A7U134	1820-3443	2	1	IC DRVR TTL AS LINE GATED HEX 2-INP	28480	1820-3443
A7U135	1820-2058	3	4	IC MISC TTL S QUAD	07263	MC3448AL
A7U136	1820-2058	3		IC MISC TTL S QUAD	07263	MC3448AL
A7U137	1820-2058	3		IC MISC TTL S QUAD	07263	MC3448AL
A7U138	1820-2058	3		IC MISC TTL S QUAD	07263	MC3448AL
A7U139	1820-3121	3		IC TRANSCEIVER TTL ALS BUS OCTL	28480	1820-3121
A7U140	1820-2488	3	1	IC FF TTL D-TYPE DUAL		SN74ALS74N
A7XL	1252-0720	7	2	CONN DIN 96PF	28480	1252-0720
A7XR	1252-0720	7		CONN DIN 96PF	28480	1252-0720
	4040-0748	3	1	EXTR-PC BD BLK POLYC .062-BD-THKNS	28480	4040-0748
	4040-0755	2	1	EXTR-PC BD VIO POLYC .062-BD-THKNS	28480	4040-0755

See introduction to this section for ordering information.
 * Indicates factory selected value.

Table 6-3. Replaceable Parts (continued)

Reference Designator	HP Part Number	C D	Qty.	Description	Mfr Code	Mfr Part Number
A8	04194-66508	8	1	MEASUREMENT CONTROL PROCESS BOARD ASSEMBLY	28480	04194-66508
A8C1	0160-4832	4	42	CAPACITOR-FXD .01UF +-10% 100VDC CER	28480	0160-4832
A8C2	0160-4832	4		CAPACITOR-FXD .01UF +-10% 100VDC CER	28480	0160-4832
A8C3	0160-4832	4		CAPACITOR-FXD .01UF +-10% 100VDC CER	28480	0160-4832
A8C4	0160-4832	4		CAPACITOR-FXD .01UF +-10% 100VDC CER	28480	0160-4832
A8C5	0160-4832	4		CAPACITOR-FXD .01UF +-10% 100VDC CER	28480	0160-4832
A8C6	0160-4832	4		CAPACITOR-FXD .01UF +-10% 100VDC CER	28480	0160-4832
A8C7	0160-4832	4		CAPACITOR-FXD .01UF +-10% 100VDC CER	28480	0160-4832
A8C8	0160-4832	4		CAPACITOR-FXD .01UF +-10% 100VDC CER	28480	0160-4832
A8C9	0160-4832	4		CAPACITOR-FXD .01UF +-10% 100VDC CER	28480	0160-4832
A8C10	0160-4832	4		CAPACITOR-FXD .01UF +-10% 100VDC CER	28480	0160-4832
A8C11	0160-4832	4		CAPACITOR-FXD .01UF +-10% 100VDC CER	28480	0160-4832
A8C12	0160-4832	4		CAPACITOR-FXD .01UF +-10% 100VDC CER	28480	0160-4832
A8C13	0160-4832	4		CAPACITOR-FXD .01UF +-10% 100VDC CER	28480	0160-4832
A8C14	0160-4832	4		CAPACITOR-FXD .01UF +-10% 100VDC CER	28480	0160-4832
A8C15	0160-4832	4		CAPACITOR-FXD .01UF +-10% 100VDC CER	28480	0160-4832
A8C16	0160-4832	4		CAPACITOR-FXD .01UF +-10% 100VDC CER	28480	0160-4832
A8C17	0160-4832	4		CAPACITOR-FXD .01UF +-10% 100VDC CER	28480	0160-4832
A8C18	0160-4832	4		CAPACITOR-FXD .01UF +-10% 100VDC CER	28480	0160-4832
A8C19	0160-4832	4		CAPACITOR-FXD .01UF +-10% 100VDC CER	28480	0160-4832
A8C20	0160-4832	4		CAPACITOR-FXD .01UF +-10% 100VDC CER	28480	0160-4832
A8C21	0160-4832	4		CAPACITOR-FXD .01UF +-10% 100VDC CER	28480	0160-4832
A8C22	0160-4832	4		CAPACITOR-FXD .01UF +-10% 100VDC CER	28480	0160-4832
A8C23	0160-4832	4		CAPACITOR-FXD .01UF +-10% 100VDC CER	28480	0160-4832
A8C24	0160-4832	4		CAPACITOR-FXD .01UF +-10% 100VDC CER	28480	0160-4832
A8C25	0160-4832	4		CAPACITOR-FXD .01UF +-10% 100VDC CER	28480	0160-4832
A8C26	0160-4832	4		CAPACITOR-FXD .01UF +-10% 100VDC CER	28480	0160-4832
A8C27	0160-4832	4		CAPACITOR-FXD .01UF +-10% 100VDC CER	28480	0160-4832
A8C28	0160-4832	4		CAPACITOR-FXD .01UF +-10% 100VDC CER	28480	0160-4832
A8C29	0160-4832	4		CAPACITOR-FXD .01UF +-10% 100VDC CER	28480	0160-4832
A8C30	0160-4832	4		CAPACITOR-FXD .01UF +-10% 100VDC CER	28480	0160-4832
A8C31	0160-4832	4		CAPACITOR-FXD .01UF +-10% 100VDC CER	28480	0160-4832
A8C32	0160-4832	4		CAPACITOR-FXD .01UF +-10% 100VDC CER	28480	0160-4832
A8C33	0160-4832	4		CAPACITOR-FXD .01UF +-10% 100VDC CER	28480	0160-4832
A8C34	0160-4832	4		CAPACITOR-FXD .01UF +-10% 100VDC CER	28480	0160-4832
A8C35	0160-4832	4		CAPACITOR-FXD .01UF +-10% 100VDC CER	28480	0160-4832
A8C36	0160-4832	4		CAPACITOR-FXD .01UF +-10% 100VDC CER	28480	0160-4832
A8C37	0160-4832	4		CAPACITOR-FXD .01UF +-10% 100VDC CER	28480	0160-4832
A8C38	0160-4832	4		CAPACITOR-FXD .01UF +-10% 100VDC CER	28480	0160-4832
A8C39	0160-4832	4		CAPACITOR-FXD .01UF +-10% 100VDC CER	28480	0160-4832
A8C40	0160-4832	4		CAPACITOR-FXD .01UF +-10% 100VDC CER	28480	0160-4832
A8C41	0160-4832	4		CAPACITOR-FXD .01UF +-10% 100VDC CER	28480	0160-4832
A8C42	0160-4832	4		CAPACITOR-FXD .01UF +-10% 100VDC CER	28480	0160-4832
A8C43	0180-3217	9	2	CAPACITOR-FXD 470UF	28480	0180-3217
A8C44	0180-3217	9		CAPACITOR-FXD 470UF	28480	0180-3217
A8DS1	1990-0665	3	9	LED-LAMP LUM-INT=1MCD IF=20MA-MAX BVR=5V	28480	1990-0665
A8DS2	1990-0665	3		LED-LAMP LUM-INT=1MCD IF=20MA-MAX BVR=5V	28480	1990-0665
A8DS3	1990-0665	3		LED-LAMP LUM-INT=1MCD IF=20MA-MAX BVR=5V	28480	1990-0665

See introduction to this section for ordering information.
 * Indicates factory selected value.

Table 6-3. Replaceable Parts (continued)

Reference Designator	HP Part Number	C D	Qty.	Description	Mfr Code	Mfr Part Number
A8DS4	1990-0665	3		LED-LAMP LUM-INT=1MCD IF=20MA-MAX BVR=5V	28480	1990-0665
A8DS5	1990-0665	3		LED-LAMP LUM-INT=1MCD IF=20MA-MAX BVR=5V	28480	1990-0665
A8DS6	1990-0665	3		LED-LAMP LUM-INT=1MCD IF=20MA-MAX BVR=5V	28480	1990-0665
A8DS7	1990-0665	3		LED-LAMP LUM-INT=1MCD IF=20MA-MAX BVR=5V	28480	1990-0665
A8DS8	1990-0665	3		LED-LAMP LUM-INT=1MCD IF=20MA-MAX BVR=5V	28480	1990-0665
A8DS9	1990-0665	3		LED-LAMP LUM-INT=1MCD IF=20MA-MAX BVR=5V	28480	1990-0665
A8F1	2110-0592	2	1	FUSE 4A 125V NTD .281X.093	28480	2110-0592
A8J1	1200-0567	1	18	SOCKET-1C 28-CONT DIP DIP-SLDR	28480	1200-0567
A8J2	1200-0567	1		SOCKET-1C 28-CONT DIP DIP-SLDR	28480	1200-0567
A8J3	1200-0567	1		SOCKET-1C 28-CONT DIP DIP-SLDR	28480	1200-0567
A8J4	1200-0567	1		SOCKET-1C 28-CONT DIP DIP-SLDR	28480	1200-0567
A8J5	1200-0567	1		SOCKET-1C 28-CONT DIP DIP-SLDR	28480	1200-0567
A8J6	1200-0567	1		SOCKET-1C 28-CONT DIP DIP-SLDR	28480	1200-0567
A8J7	1200-0567	1		SOCKET-1C 28-CONT DIP DIP-SLDR	28480	1200-0567
A8J8	1200-0567	1		SOCKET-1C 28-CONT DIP DIP-SLDR	28480	1200-0567
A8J9	1200-0567	1		SOCKET-1C 28-CONT DIP DIP-SLDR	28480	1200-0567
A8J10	1200-0567	1		SOCKET-1C 28-CONT DIP DIP-SLDR	28480	1200-0567
A8J11	1200-0567	1		SOCKET-1C 28-CONT DIP DIP-SLDR	28480	1200-0567
A8J12	1200-0567	1		SOCKET-1C 28-CONT DIP DIP-SLDR	28480	1200-0567
A8J13	1200-0567	1		SOCKET-1C 28-CONT DIP DIP-SLDR	28480	1200-0567
A8J14	1200-0567	1		SOCKET-1C 28-CONT DIP DIP-SLDR	28480	1200-0567
A8J15	1200-0567	1		SOCKET-1C 28-CONT DIP DIP-SLDR	28480	1200-0567
A8J16	1200-0567	1		SOCKET-1C 28-CONT DIP DIP-SLDR	28480	1200-0567
A8J17	1200-0567	1		SOCKET-1C 28-CONT DIP DIP-SLDR	28480	1200-0567
A8J18	1200-0567	1		SOCKET-1C 28-CONT DIP DIP-SLDR	28480	1200-0567
A8J19	1200-0944	8	1	SOCKET-1C 64-CONT DIP-SLDR	28480	1200-0944
A8L1	9170-0847	3	4	CORE-SHIELDING BEAD	02114	56-590-65/3B
A8R1	1810-0273	9	1	NETWORK-RES 10-SIP470.0 OHM X 9	01121	210A471
A8R2	1810-0279	5	11	NETWORK-RES 10-SIP4.7K OHM X 9	01121	210A472
A8R3	1810-0279	5		NETWORK-RES 10-SIP4.7K OHM X 9	01121	210A472
A8R4	1810-0279	5		NETWORK-RES 10-SIP4.7K OHM X 9	01121	210A472
A8R5	1810-0279	5		NETWORK-RES 10-SIP4.7K OHM X 9	01121	210A472
A8R6	1810-0279	5		NETWORK-RES 10-SIP4.7K OHM X 9	01121	210A472
A8R7	0698-3155	1	3	RESISTOR 4.64K 1% .125W F TC=0+-100	24546	C4-1/8-T0-4641-F
A8R8	0698-3155	1		RESISTOR 4.64K 1% .125W F TC=0+-100	24546	C4-1/8-T0-4641-F
A8R9	0698-3155	1		RESISTOR 4.64K 1% .125W F TC=0+-100	24546	C4-1/8-T0-4641-F
A8R10	1810-0279	5		NETWORK-RES 10-SIP4.7K OHM X 9	01121	210A472
A8R11	1810-0279	5		NETWORK-RES 10-SIP4.7K OHM X 9	01121	210A472
A8R12	1810-0279	5		NETWORK-RES 10-SIP4.7K OHM X 9	01121	210A472
A8R13	1810-0279	5		NETWORK-RES 10-SIP4.7K OHM X 9	01121	210A472
A8R14	1810-0279	5		NETWORK-RES 10-SIP4.7K OHM X 9	01121	210A472
A8R15	1810-0269	3	5	NETWORK-RES 9-SIP10.0K OHM X 8	28480	1810-0269
A8R16	1810-0269	3		NETWORK-RES 9-SIP10.0K OHM X 8	28480	1810-0269
A8R17	1810-0269	3		NETWORK-RES 9-SIP10.0K OHM X 8	28480	1810-0269
A8R18	1810-0269	3		NETWORK-RES 9-SIP10.0K OHM X 8	28480	1810-0269
A8R19	1810-0269	3		NETWORK-RES 9-SIP10.0K OHM X 8	28480	1810-0269
A8R20	1810-0279	5		NETWORK-RES 10-SIP4.7K OHM X 9	01121	210A472
A8R21	0757-0442	9	2	RESISTOR 10K 1% .125W F TC=0+-100	24546	C4-1/8-T0-1002-F
A8R22	0757-0442	9		RESISTOR 10K 1% .125W F TC=0+-100	24546	C4-1/8-T0-1002-F

See introduction to this section for ordering information.
 * Indicates factory selected value.

Table 6-3. Replaceable Parts (continued)

Reference Designator	HP Part Number	C D	Qty.	Description	Mfr Code	Mfr Part Number
A8SW1	3101-2831	8	1	SWITCH 8P	28480	3101-2831
A8SW2	3101-2832	9	1	SWITCH 4P	28480	3101-2832
A8U1	04194-85631	8	1	ROM PROGRAMMED	28480	04194-85631
A8U2	04194-85632	9	1	ROM PROGRAMMED	28480	04194-85632
A8U3	04194-85633	0	1	ROM PROGRAMMED	28480	04194-85633
A8U4	04194-85634	1	1	ROM PROGRAMMED	28480	04194-85634
A8U5	04194-85635	2	1	ROM PROGRAMMED	28480	04194-85635
A8U6	04194-85636	3	1	ROM PROGRAMMED	28480	04194-85636
A8U7	04194-85637	4	1	ROM PROGRAMMED	28480	04194-85637
A8U8	04194-85638	5	1	ROM PROGRAMMED	28480	04194-85638
A8U9	04194-85639	6	1	ROM PROGRAMMED	28480	04194-85639
A8U10	04194-85640	9	1	ROM PROGRAMMED	28480	04194-85640
A8U11	1818-3183	2	6	IC CMOS 65536 (64K) STAT RAM 150-NS 3-S	28480	1818-3183
A8U12	1818-3183	2		IC CMOS 65536 (64K) STAT RAM 150-NS 3-S	28480	1818-3183
A8U13	1818-3183	2		IC CMOS 65536 (64K) STAT RAM 150-NS 3-S	28480	1818-3183
A8U14	1818-3183	2		IC CMOS 65536 (64K) STAT RAM 150-NS 3-S	28480	1818-3183
A8U15	1818-3183	2		IC CMOS 65536 (64K) STAT RAM 150-NS 3-S	28480	1818-3183
A8U16	1818-3183	2		IC CMOS 65536 (64K) STAT RAM 150-NS 3-S	28480	1818-3183
A8U17	1818-3801	1	1	IC EEPROM		
A8U18				NOT ASSIGNED		
A8U19	1820-2757	9	1	IC FF TTL ALS D-TYPE POS-EDGE-TRIG OCTL	01295	SN74ALS574N
A8U20	1820-1975	1	2	IC SHF-RGTR TTL LS NEG-EDGE-TRIG PRL-IN	01295	SN74LS165N
A8U21	1820-1975	1		IC SHF-RGTR TTL LS NEG-EDGE-TRIG PRL-IN	01295	SN74LS165N
A8U22	04194-80005	0	1	DM PAL12L6NC	28480	04194-80005
A8U23	1820-2488	3	3	IC FF TTL ALS D-TYPE POS-EDGE-TRIG	01295	SN74ALS74N
A8U24	1820-3145	1	4	IC DRVR TTL ALS BUS OCTL	28480	1820-3145
A8U25	1820-1858	9	3	IC FF TTL LS D-TYPE OCTL	01295	SN74LS377N
A8U26	04194-80004	9	1	AM PAL16R4ADC	28480	04194-80004
A8U27	1820-3100	8	5	IC DCDR TTL ALS BIN 3-TO-8-LINE 3-INP	28480	1820-3100
A8U28	1820-3121	3	8	IC TRANSCEIVER TTL ALS BUS OCTL	28480	1820-3121
A8U29	1820-1245	8	1	IC DCDR TTL LS 2-TO-4-LINE DUAL 2-INP	01295	SN74LS155N
A8U30	1820-3121	3		IC TRANSCEIVER TTL ALS BUS OCTL	28480	1820-3121
A8U31	1820-3320	4	1	IC-16BIT,10MHZ,CERAMIC MPU W/32 BIT DATA	28480	1820-3320
A8U32	1820-3121	3		IC TRANSCEIVER TTL ALS BUS OCTL	28480	1820-3121
A8U33	1820-1851	2	1	IC ENCDR TTL LS	01295	SN74LS148N
A8U34	1820-2772	8	1	IC FF TTL ALS J-K NEG-EDGE-TRIG	01295	SN74ALS112N
A8U35	1820-2634	1	3	IC INV TTL ALS HEX	01295	SN74ALS04N
A8U36	1820-2657	8	4	IC GATE TTL ALS OR QUAD 2-INP	01295	SN74ALS32N
A8U37	1820-2774	0	1	IC GATE TTL ALS NAND DUAL 4-INP	01295	SN74ALS20N
A8U38	1820-3220	3	1	IC DCDR TTL F BIN 2-TO-4-LINE DUAL	28480	1820-3220
A8U39	1820-2758	0	3	IC FF TTL ALS J-K BAR POS-EDGE-TRIG	01295	SN74ALS109N
A8U40	1820-1469	8	2	IC FF TTL LS J-K NEG-EDGE-TRIG CLEAR	01295	SN74LS107AN
A8U41	1820-2777	3	2	IC CNTR TTL ALS BIN SYNCHRO	01295	SN74ALS161N
A8U42	1820-2657	8		IC GATE TTL ALS OR QUAD 2-INP	01295	SN74ALS32N
A8U43	1820-2873	0	3	IC-UPD8253-5	28480	1820-2873
A8U44	1820-2873	0		IC-UPD8253-5	28480	1820-2873
A8U45	1820-2873	0		IC-UPD8253-5	28480	1820-2873
A8U46	1820-2711	5	7	IC DRVR TTL LS LINE DRVR OCTL	01295	SN74LS541N
A8U47	1820-3836	7	1	IC GATE-ARY CMOS	28480	1820-3836

See introduction to this section for ordering information.
* Indicates factory selected value.

Table 6-3. Replaceable Parts (continued)

Reference Designator	HP Part Number	C D	Qty.	Description	Mfr Code	Mfr Part Number
A8U48	1820-2775	1	1	IC GATE TTL ALS NAND TPL 3-INP	01295	SN74ALS10N
A8U49	1820-3121	3		IC TRANSCEIVER TTL ALS BUS OCTL	28480	1820-3121
A8U50	1820-3100	8		IC DCDR TTL ALS BIN 3-TO-8-LINE 3-INP	28480	1820-3100
A8U51	1820-3318	0	1	IC FF TTL ALS D-TYPE POS-EDGE-TRIG COM	28480	1820-3318
A8U52	1820-3480	7	1	IC DRVR TTL ALS AND QUAD 2-INP	28480	1820-3480
A8U53	1820-2506	6	1	IC INV TTL F HEX	07263	74F04PC
A8U54	1820-2777	3		IC CNTR TTL ALS BIN SYNCHRO	01295	SN74ALS161N
A8U55	1820-2656	7	3	IC GATE TTL ALS NAND QUAD 2-INP	01295	SN74ALS00N
A8U56	1820-2657	8		IC GATE TTL ALS OR QUAD 2-INP	01295	SN74ALS32N
A8U57	1820-2758	0		IC FF TTL ALS J-K BAR POS-EDGE-TRIG	01295	SN74ALS109N
A8U58	1820-2758	0		IC FF TTL ALS J-K BAR POS-EDGE-TRIG	01295	SN74ALS109N
A8U59	1820-2656	7		IC GATE TTL ALS NAND QUAD 2-INP	01295	SN74ALS00N
A8U60	1820-3100	8		IC DCDR TTL ALS BIN 3-TO-8-LINE 3-INP	28480	1820-3100
A8U61	1820-2711	5		IC DRVR TTL LS LINE DRVR OCTL	01295	SN74LS541N
A8U62	1820-3100	8		IC DCDR TTL ALS BIN 3-TO-8-LINE 3-INP	28480	1820-3100
A8U63	1820-3100	8		IC DCDR TTL ALS BIN 3-TO-8-LINE 3-INP	28480	1820-3100
A8U64	1820-3121	3		IC TRANSCEIVER TTL ALS BUS OCTL	28480	1820-3121
A8U65	1820-2711	5		IC DRVR TTL LS LINE DRVR OCTL	01295	SN74LS541N
A8U66	1820-1858	9		IC FF TTL LS D-TYPE OCTL	01295	SN74LS377N
A8U67	1820-1858	9		IC FF TTL LS D-TYPE OCTL	01295	SN74LS377N
A8U68	1820-2711	5		IC DRVR TTL LS LINE DRVR OCTL	01295	SN74LS541N
A8U69	1820-2634	1		IC INV TTL ALS HEX	01295	SN74ALS04N
A8U70	1820-2488	3		IC FF TTL ALS D-TYPE POS-EDGE-TRIG	01295	SN74ALS74N
A8U71	1820-2488	3		IC FF TTL ALS D-TYPE POS-EDGE-TRIG	01295	SN74ALS74N
A8U72	1820-2635	2	2	IC GATE TTL ALS AND QUAD 2-INP	01295	SN74ALS08N
A8U73	1820-2711	5		IC DRVR TTL LS LINE DRVR OCTL	01295	SN74LS541N
A8U74	1820-2711	5		IC DRVR TTL LS LINE DRVR OCTL	01295	SN74LS541N
A8U75	1820-3121	3		IC TRANSCEIVER TTL ALS BUS OCTL	28480	1820-3121
A8U76	1820-3121	3		IC TRANSCEIVER TTL ALS BUS OCTL	28480	1820-3121
A8U77	1820-2711	5		IC DRVR TTL LS LINE DRVR OCTL	01295	SN74LS541N
A8U78	1820-2634	1		IC INV TTL ALS HEX	01295	SN74ALS04N
A8U79	1820-3121	3		IC TRANSCEIVER TTL ALS BUS OCTL	28480	1820-3121
A8U80	1820-3376	0	1	IC INV TTL ALS HEX	28480	1820-3376
A8U81	1820-3145	1		IC DRVR TTL ALS BUS OCTL	28480	1820-3145
A8U82	1820-3145	1		IC DRVR TTL ALS BUS OCTL	28480	1820-3145
A8U83	1820-3145	1		IC DRVR TTL ALS BUS OCTL	28480	1820-3145
A8U84	1820-2656	7		IC GATE TTL ALS NAND QUAD 2-INP	01295	SN74ALS00N
A8U85	1820-2657	8		IC GATE TTL ALS OR QUAD 2-INP	01295	SN74ALS32N
A8U86	1820-1469	8		IC FF TTL LS J-K NEG-EDGE-TRIG CLEAR	01295	SN74LS107AN
A8U87	1820-2635	2		IC GATE TTL ALS AND QUAD 2-INP	01295	SN74ALS08N
A8W1	1251-4822	6	6	CONNECTOR 3-PIN M POST TYPE	28480	1251-4822
A8W2	1251-4822	6		CONNECTOR 3-PIN M POST TYPE	28480	1251-4822
A8W3	1251-4822	6		CONNECTOR 3-PIN M POST TYPE	28480	1251-4822
A8W4	1251-4822	6		CONNECTOR 3-PIN M POST TYPE	28480	1251-4822
A8W5	1251-4822	6		CONNECTOR 3-PIN M POST TYPE	28480	1251-4822
A8W6	1251-4822	6		CONNECTOR 3-PIN M POST TYPE	28480	1251-4822
A8XL	1252-0720	7	2	CONN DIN 96PF	28480	1252-0720
A8XR	1252-0720	7		CONN DIN 96PF	28480	1252-0720

See introduction to this section for ordering information.
 * Indicates factory selected value.

Table 6-3. Replaceable Parts (continued)

Reference Designator	HP Part Number	C D	Qty.	Description	Mfr Code	Mfr Part Number
	4040-0747	2	1	EXTR-PC BD GRA POLYC .062-BD-THKNS	28480	4040-0747
	4040-0748	3	1	EXTR-PC BD BLK POLYC .062-BD-THKNS	28480	4040-0748

See introduction to this section for ordering information.
 * Indicates factory selected value.

Table 6-3. Replaceable Parts (continued)

Reference Designator	HP Part Number	C D	Qty.	Description	Mfr Code	Mfr Part Number
A9	04194-66509	9	1	PHASE DETECTOR/A-D CONVERTER BOARD ASSEMBLY	28480	04194-66509
A9C1	0160-4792	5	2	CAPACITOR-FXD 8.2PF +- .5PF 100VDC CER	28480	0160-4792
A9C2	0160-4800	6	2	CAPACITOR-FXD 120PF +-5% 100VDC CER	28480	0160-4800
A9C3	0160-4791	4	2	CAPACITOR-FXD 10PF +-5% 100VDC CER 0+-30	28480	0160-4791
A9C4	0160-4805	1	2	CAPACITOR-FXD 47PF +-5% 100VDC CER 0+-30	28480	0160-4805
A9C5	0121-0453	5	1	CAPACITOR-V TRMR-AIR 1.3-5.4PF 175V	74970	187-0303-125
A9C6	0160-4833	5	1	CAPACITOR-FXD .022UF +-10% 100VDC CER	28480	0160-4833
A9C7	0160-4801	7	2	CAPACITOR-FXD 100PF +-5% 100VDC CER	28480	0160-4801
A9C8	0160-4801	7		CAPACITOR-FXD 100PF +-5% 100VDC CER	28480	0160-4801
A9C9	0160-4835	7	16	CAPACITOR-FXD .1UF +-10% 50VDC CER	28480	0160-4835
A9C10	0160-4835	7		CAPACITOR-FXD .1UF +-10% 50VDC CER	28480	0160-4835
A9C11	0160-4805	1		CAPACITOR-FXD 47PF +-5% 100VDC CER 0+-30	28480	0160-4805
A9C12	0160-6346	9	2	CAPACITOR-FXD 2700PF +-5% 100VDC POLYP	28480	0160-6346
A9C13	0160-4835	7		CAPACITOR-FXD .1UF +-10% 50VDC CER	28480	0160-4835
A9C14	0160-4835	7		CAPACITOR-FXD .1UF +-10% 50VDC CER	28480	0160-4835
A9C15	0180-3469	3	1	CAPACITOR-FXD 100UF +-20% 25VDC AL	28480	0180-3469
A9C16	0160-4800	6		CAPACITOR-FXD 120PF +-5% 100VDC CER	28480	0160-4800
A9C17	0160-4792	5		CAPACITOR-FXD 8.2PF +- .5PF 100VDC CER	28480	0160-4792
A9C18	0180-3363	6	7	CAPACITOR-FXD 22UF +-20% 25VDC AL	28480	0180-3363
A9C19	0180-3363	6		CAPACITOR-FXD 22UF +-20% 25VDC AL	28480	0180-3363
A9C20	0160-4791	4		CAPACITOR-FXD 10PF +-5% 100VDC CER 0+-30	28480	0160-4791
A9C21	0180-3363	6		CAPACITOR-FXD 22UF +-20% 25VDC AL	28480	0180-3363
A9C22	0180-3363	6		CAPACITOR-FXD 22UF +-20% 25VDC AL	28480	0180-3363
A9C23	0160-4794	7	1	CAPACITOR-FXD 5.6PF +- .5PF 100VDC CER	28480	0160-4794
A9C24	0180-3363	6		CAPACITOR-FXD 22UF +-20% 25VDC AL	28480	0180-3363
A9C25	0180-3363	6		CAPACITOR-FXD 22UF +-20% 25VDC AL	28480	0180-3363
A9C26	0160-4835	7		CAPACITOR-FXD .1UF +-10% 50VDC CER	28480	0160-4835
A9C27	0160-4835	7		CAPACITOR-FXD .1UF +-10% 50VDC CER	28480	0160-4835
A9C28	0160-4835	7		CAPACITOR-FXD .1UF +-10% 50VDC CER	28480	0160-4835
A9C29	0160-4835	7		CAPACITOR-FXD .1UF +-10% 50VDC CER	28480	0160-4835
A9C30	0180-3363	6		CAPACITOR-FXD 22UF +-20% 25VDC AL	28480	0180-3363
A9C31	0160-6341	4	2	CAPACITOR-FXD 0.018U 100V	28480	0160-6341
A9C32	0160-4835	7		CAPACITOR-FXD .1UF +-10% 50VDC CER	28480	0160-4835
A9C33	0160-4835	7		CAPACITOR-FXD .1UF +-10% 50VDC CER	28480	0160-4835
A9C34	0160-4835	7		CAPACITOR-FXD .1UF +-10% 50VDC CER	28480	0160-4835
A9C35	0160-4835	7		CAPACITOR-FXD .1UF +-10% 50VDC CER	28480	0160-4835
A9C36	0160-4835	7		CAPACITOR-FXD .1UF +-10% 50VDC CER	28480	0160-4835
A9C37	0160-4823	3	1	CAPACITOR-FXD 820PF +-5% 100VDC CER	28480	0160-4823
A9C38				NOT ASSIGNED		
A9C39	0160-6346	9		CAPACITOR-FXD 2700PF +-5% 100VDC POLYP	28480	0160-6346
A9C40	0160-6341	4		CAPACITOR-FXD 0.018U 100V	28480	0160-6341
A9C41	0160-4810	8	1	CAPACITOR-FXD 330PF +-5% 100VDC CER	28480	0160-4810
A9C42	0160-4835	7		CAPACITOR-FXD .1UF +-10% 50VDC CER	28480	0160-4835
A9C43	0160-4835	7		CAPACITOR-FXD .1UF +-10% 50VDC CER	28480	0160-4835
A9C44	0160-4835	7		CAPACITOR-FXD .1UF +-10% 50VDC CER	28480	0160-4835
A9C45	0180-3471	7	3	CAPACITOR-FXD 470UF +-20% 25VDC AL	28480	0180-3471
A9C46	0180-3470	6	3	CAPACITOR-FXD 220UF +-20% 25VDC AL	28480	0180-3470

See introduction to this section for ordering information.
* Indicates factory selected value.

Table 6-3. Replaceable Parts (continued)

Reference Designator	HP Part Number	C D	Qty.	Description	Mfr Code	Mfr Part Number
A9C47	0180-3471	7		CAPACITOR-FXD 470UF +-20% 25VDC AL	28480	0180-3471
A9C48	0180-3470	6		CAPACITOR-FXD 220UF +-20% 25VDC AL	28480	0180-3470
A9C49	0180-3470	6		CAPACITOR-FXD 220UF +-20% 25VDC AL	28480	0180-3470
A9C50	0180-3471	7		CAPACITOR-FXD 470UF +-20% 25VDC AL	28480	0180-3471
A9CR1	1902-0071	0	1	DIODE-ZNR 9V 5% DO-14 PD=.4W TC=+.001%	28480	1902-0071
A9CR2	1902-0945	7	2	DIODE-ZNR 3V 5% DO-35 PD=.4W TC=-.043%	28480	1902-0945
A9CR3	1902-0945	7		DIODE-ZNR 3V 5% DO-35 PD=.4W TC=-.043%	28480	1902-0945
A9CR4	1902-0952	6	1	DIODE-ZNR 5.6V 5% DO-35 PD=.4W TC=+.046%	28480	1902-0952
A9CR5	1901-0050	3	4	DIODE-SWITCHING 80V 200MA 2NS DO-35	28480	1901-0050
A9CR6	1901-1011	8	2	DIODE-ARRAY VF DIFF=5MV	28480	1901-1011
A9CR7	1901-0050	3		DIODE-SWITCHING 80V 200MA 2NS DO-35	28480	1901-0050
A9CR8	1901-0050	3		DIODE-SWITCHING 80V 200MA 2NS DO-35	28480	1901-0050
A9CR9	1901-1011	8		DIODE-ARRAY VF DIFF=5MV	28480	1901-1011
A9CR10	1901-0050	3		DIODE-SWITCHING 80V 200MA 2NS DO-35	28480	1901-0050
A9F1	2110-0002	9	1	FUSE 2A 250V NTD 1.25X.25 UL	75915	312002
A9F2	2110-0043	8	1	FUSE 1.5A 250V NTD 1.25X.25 UL	28480	2110-0043
A9F3	2110-0012	1	1	FUSE .5A 250V NTD 1.25X.25 UL	28480	2110-0012
A9L1	9140-0137	1	1	INDUCTOR RF-CH-MLD 1MH 5% .2DX.45LG Q=60	28480	9140-0137
A9L2	9100-3139	5	3	INDUCTOR 75UH 15% .5DX.875LG	28480	9100-3139
A9L3	9100-3139	5		INDUCTOR 75UH 15% .5DX.875LG	28480	9100-3139
A9L4	9100-3139	5		INDUCTOR 75UH 15% .5DX.875LG	28480	9100-3139
A9Q1	1854-0810	2	4	TRANSISTOR NPN SI PD=625MW FT=200MHZ	28480	1854-0810
A9Q2	1854-0810	2		TRANSISTOR NPN SI PD=625MW FT=200MHZ	28480	1854-0810
A9Q3	1853-0459	3	2	TRANSISTOR PNP SI PD=625MW FT=200MHZ	28480	1853-0459
A9Q4	1854-0810	2		TRANSISTOR NPN SI PD=625MW FT=200MHZ	28480	1854-0810
A9Q5	1854-0810	2		TRANSISTOR NPN SI PD=625MW FT=200MHZ	28480	1854-0810
A9Q6	1853-0459	3		TRANSISTOR PNP SI PD=625MW FT=200MHZ	28480	1853-0459
A9Q7	1854-1074	2	1	TRANSISTOR NPN SI PD=200MW FT=30MHZ	28480	1854-1074
A9Q8	1855-0410	0	2	TRANSISTOR J-FET N-CHAN D-MODE TO-18 SI	28480	1855-0410
A9Q9	1855-0410	0		TRANSISTOR J-FET N-CHAN D-MODE TO-18 SI	28480	1855-0410
A9Q10	1854-0063	7	2	TRANSISTOR NPN 2N3055 SI TO-3 PD=115W	3L585	2N3055
A9Q11	1854-0063	7		TRANSISTOR NPN 2N3055 SI TO-3 PD=115W	3L585	2N3055
A9Q12	1853-0413	9	1	TRANSISTOR PNP 2N6049 SI TO-66 PD=75W	28480	1853-0413
A9R1	0757-0280	3	20	RESISTOR 1K 1% .125W F TC=0+-100	24546	C4-1/8-T0-1001-F
A9R2	0757-0280	3		RESISTOR 1K 1% .125W F TC=0+-100	24546	C4-1/8-T0-1001-F
A9R3	2100-3056	8	1	RESISTOR-TRMR 5K 10% C SIDE-ADJ 17-TRN	02111	43P502
A9R4	0698-4501	3	1	RESISTOR 59K 1% .125W F TC=0+-100	24546	C4-1/8-T0-5902-F
A9R5	0757-0452	1	1	RESISTOR 27.4K 1% .125W F TC=0+-100	24546	C4-1/8-T0-2742-F
A9R6	0698-3154	0	1	RESISTOR 4.22K 1% .125W F TC=0+-100	24546	C4-1/8-T0-4221-F
A9R7				NOT ASSIGNED		
A9R8	0698-3430	5	7	RESISTOR 21.5 1% .125W F TC=0+-100	03888	PME55-1/8-T0-21R5-F
A9R9	0757-0280	3		RESISTOR 1K 1% .125W F TC=0+-100	24546	C4-1/8-T0-1001-F
A9R10	0757-0280	3		RESISTOR 1K 1% .125W F TC=0+-100	24546	C4-1/8-T0-1001-F
A9R11	0757-0438	3	7	RESISTOR 5.11K 1% .125W F TC=0+-100	24546	C4-1/8-T0-5111-F
A9R12	0757-0290	5	1	RESISTOR 6.19K 1% .125W F TC=0+-100	19701	MF4C1/8-T0-6191-F
A9R13	0698-3438	3	1	RESISTOR 147 1% .125W F TC=0+-100	24546	C4-1/8-T0-147R-F
A9R14	2100-3352	7	1	RESISTOR-TRMR 1K 10% C SIDE-ADJ 1-TRN	28480	2100-3352
A9R15	0757-0434	9	1	RESISTOR 3.65K 1% .125W F TC=0+-100	24546	C4-1/8-T0-3651-F
A9R16	0757-0438	3		RESISTOR 5.11K 1% .125W F TC=0+-100	24546	C4-1/8-T0-5111-F

See introduction to this section for ordering information.
 * Indicates factory selected value.

Table 6-3. Replaceable Parts (continued)

Reference Designator	HP Part Number	C D	Qty.	Description	Mfr Code	Mfr Part Number
A9R17	0757-0280	3		RESISTOR 1K 1% .125W F TC=0+-100	24546	C4-1/8-T0-1001-F
A9R18	0757-0280	3		RESISTOR 1K 1% .125W F TC=0+-100	24546	C4-1/8-T0-1001-F
A9R19	0757-0280	3		RESISTOR 1K 1% .125W F TC=0+-100	24546	C4-1/8-T0-1001-F
A9R20	0757-0438	3		RESISTOR 5.11K 1% .125W F TC=0+-100	24546	C4-1/8-T0-5111-F
A9R21	0757-0438	3		RESISTOR 5.11K 1% .125W F TC=0+-100	24546	C4-1/8-T0-5111-F
A9R22	0757-0280	3		RESISTOR 1K 1% .125W F TC=0+-100	24546	C4-1/8-T0-1001-F
A9R23	0757-0438	3		RESISTOR 5.11K 1% .125W F TC=0+-100	24546	C4-1/8-T0-5111-F
A9R24	0757-0438	3		RESISTOR 5.11K 1% .125W F TC=0+-100	24546	C4-1/8-T0-5111-F
A9R25	0757-0280	3		RESISTOR 1K 1% .125W F TC=0+-100	24546	C4-1/8-T0-1001-F
A9R26	0698-3447	4	1	RESISTOR 422 1% .125W F TC=0+-100	24546	C4-1/8-T0-422R-F
A9R27	0698-3160	8	5	RESISTOR 31.6K 1% .125W F TC=0+-100	24546	C4-1/8-T0-3162-F
A9R28	0698-3160	8		RESISTOR 31.6K 1% .125W F TC=0+-100	24546	C4-1/8-T0-3162-F
A9R29	0757-0442	9	2	RESISTOR 10K 1% .125W F TC=0+-100	24546	C4-1/8-T0-1002-F
A9R30	0698-3441	8	1	RESISTOR 215 1% .125W F TC=0+-100	24546	C4-1/8-T0-215R-F
A9R31	0757-0280	3		RESISTOR 1K 1% .125W F TC=0+-100	24546	C4-1/8-T0-1001-F
A9R32	0757-0401	0	1	RESISTOR 100 1% .125W F TC=0+-100	24546	C4-1/8-T0-101-F
A9R33	0698-0082	7	1	RESISTOR 464 1% .125W F TC=0+-100	24546	C4-1/8-T0-4640-F
A9R34	0757-0280	3		RESISTOR 1K 1% .125W F TC=0+-100	24546	C4-1/8-T0-1001-F
A9R35	0757-0280	3		RESISTOR 1K 1% .125W F TC=0+-100	24546	C4-1/8-T0-1001-F
A9R36	0757-0280	3		RESISTOR 1K 1% .125W F TC=0+-100	24546	C4-1/8-T0-1001-F
A9R37	0757-0280	3		RESISTOR 1K 1% .125W F TC=0+-100	24546	C4-1/8-T0-1001-F
A9R38	0757-0460	1	1	RESISTOR 61.9K 1% .125W F TC=0+-100	24546	C4-1/8-T0-6192-F
A9R39	0698-3160	8		RESISTOR 31.6K 1% .125W F TC=0+-100	24546	C4-1/8-T0-3162-F
A9R40	0698-3430	5		RESISTOR 21.5 1% .125W F TC=0+-100	03888	PME55-1/8-T0-21R5-F
A9R41	0698-3430	5		RESISTOR 21.5 1% .125W F TC=0+-100	03888	PME55-1/8-T0-21R5-F
A9R42	0811-2771	7	1	RESISTOR .18 3% 3W PW TC=0+-90	28480	0811-2771
A9R43	0812-0066	1	1	RESISTOR .33 5% 2W PW TC=0+-800	75042	BWH2-33/100-J
A9R44	0811-1553	1	1	RESISTOR .68 5% 2W PW TC=0+-800	75042	BWH2-11/16-J
A9R45	0757-0200	7	4	RESISTOR 5.62K 1% .125W F TC=0+-100	24546	C4-1/8-T0-5621-F
A9R46	0757-0200	7		RESISTOR 5.62K 1% .125W F TC=0+-100	24546	C4-1/8-T0-5621-F
A9R47	0698-3499	6	2	RESISTOR 40.2K 1% .125W F TC=0+-100	24546	C4-1/8-T0-4022-F
A9R48	0698-3430	5		RESISTOR 21.5 1% .125W F TC=0+-100	03888	PME55-1/8-T0-21R5-F
A9R49	0698-3430	5		RESISTOR 21.5 1% .125W F TC=0+-100	03888	PME55-1/8-T0-21R5-F
A9R50	0757-0438	3		RESISTOR 5.11K 1% .125W F TC=0+-100	24546	C4-1/8-T0-5111-F
A9R51	0698-3430	5		RESISTOR 21.5 1% .125W F TC=0+-100	03888	PME55-1/8-T0-21R5-F
A9R52	0698-3430	5		RESISTOR 21.5 1% .125W F TC=0+-100	03888	PME55-1/8-T0-21R5-F
A9R53	0698-3260	9	1	RESISTOR 464K 1% .125W F TC=0+-100	28480	0698-3260
A9R54	0757-0280	3		RESISTOR 1K 1% .125W F TC=0+-100	24546	C4-1/8-T0-1001-F
A9R55	1810-0205	7	2	NETWORK-RES 8-SIP4.7K OHM X 7	01121	208A472
A9R56	1810-0305	8	2	NETWORK-RES 9-SIP4.7K OHM X 8	28480	1810-0305
A9R57	0698-3162	0	1	RESISTOR 46.4K 1% .125W F TC=0+-100	24546	C4-1/8-T0-4642-F
A9R58	0698-3266	5	3	RESISTOR 237K 1% .125W F TC=0+-100	24546	C4-1/8-T0-2373-F
A9R59	0698-3266	5		RESISTOR 237K 1% .125W F TC=0+-100	24546	C4-1/8-T0-2373-F
A9R60	0698-3266	5		RESISTOR 237K 1% .125W F TC=0+-100	24546	C4-1/8-T0-2373-F
A9R61	0757-0280	3		RESISTOR 1K 1% .125W F TC=0+-100	24546	C4-1/8-T0-1001-F
A9R62	0757-0280	3		RESISTOR 1K 1% .125W F TC=0+-100	24546	C4-1/8-T0-1001-F
A9R63	0698-3155	1	8	RESISTOR 4.64K 1% .125W F TC=0+-100	24546	C4-1/8-T0-4641-F
A9R64	0698-3155	1		RESISTOR 4.64K 1% .125W F TC=0+-100	24546	C4-1/8-T0-4641-F
A9R65	0698-2216	3	2	RESISTOR 20.0K OHM 0.05% 1/8W MF	28480	0698-2216

See introduction to this section for ordering information.
 * Indicates factory selected value.

Table 6-3. Replaceable Parts (continued)

Reference Designator	HP Part Number	C D	Qty.	Description	Mfr Code	Mfr Part Number
A9R66	0757-0279	0	3	RESISTOR 3.16K 1% .125W F TC=0+-100	24546	C4-1/8-T0-3161-F
A9R67	0698-3453	2	2	RESISTOR 196K 1% .125W F TC=0+-100	24546	C4-1/8-T0-1963-F
A9R68	0698-8649	8	2	RESISTOR 1.28M .1% .25W F TC=0+-25	28480	0698-8649
A9R69	0698-3155	1		RESISTOR 4.64K 1% .125W F TC=0+-100	24546	C4-1/8-T0-4641-F
A9R70	0698-3155	1		RESISTOR 4.64K 1% .125W F TC=0+-100	24546	C4-1/8-T0-4641-F
A9R71	0757-0279	0		RESISTOR 3.16K 1% .125W F TC=0+-100	24546	C4-1/8-T0-3161-F
A9R72	0757-0280	3		RESISTOR 1K 1% .125W F TC=0+-100	24546	C4-1/8-T0-1001-F
A9R73	0757-0442	9		RESISTOR 10K 1% .125W F TC=0+-100	24546	C4-1/8-T0-1002-F
A9R74	0811-1662	3	1	RESISTOR .47 5% 2W PW TC=0+-800	75042	BWH2-47/100-J
A9R75	0698-3499	6		RESISTOR 40.2K 1% .125W F TC=0+-100	24546	C4-1/8-T0-4022-F
A9R76	0757-0200	7		RESISTOR 5.62K 1% .125W F TC=0+-100	24546	C4-1/8-T0-5621-F
A9R77	0757-0200	7		RESISTOR 5.62K 1% .125W F TC=0+-100	24546	C4-1/8-T0-5621-F
A9R78	1810-0205	7		NETWORK-RES 8-SIP4.7K OHM X 7	01121	208A472
A9R79	1810-0305	8		NETWORK-RES 9-SIP4.7K OHM X 8	28480	1810-0305
A9R80	0698-0084	9	1	RESISTOR 2.15K 1% .125W F TC=0+-100	24546	C4-1/8-T0-2151-F
A9R81	0757-0280	3		RESISTOR 1K 1% .125W F TC=0+-100	24546	C4-1/8-T0-1001-F
A9R82	0757-0280	3		RESISTOR 1K 1% .125W F TC=0+-100	24546	C4-1/8-T0-1001-F
A9R83	0698-3155	1		RESISTOR 4.64K 1% .125W F TC=0+-100	24546	C4-1/8-T0-4641-F
A9R84	0698-3155	1		RESISTOR 4.64K 1% .125W F TC=0+-100	24546	C4-1/8-T0-4641-F
A9R85	0698-2216	3		RESISTOR 20.0K OHM 0.05% 1/8W MF	28480	0698-2216
A9R86	0757-0279	0		RESISTOR 3.16K 1% .125W F TC=0+-100	24546	C4-1/8-T0-3161-F
A9R87	0698-3453	2		RESISTOR 196K 1% .125W F TC=0+-100	24546	C4-1/8-T0-1963-F
A9R88	0698-8649	8		RESISTOR 1.28M .1% .25W F TC=0+-25	28480	0698-8649
A9R89	0698-3155	1		RESISTOR 4.64K 1% .125W F TC=0+-100	24546	C4-1/8-T0-4641-F
A9R90	0698-3155	1		RESISTOR 4.64K 1% .125W F TC=0+-100	24546	C4-1/8-T0-4641-F
A9R91	0698-3160	8		RESISTOR 31.6K 1% .125W F TC=0+-100	24546	C4-1/8-T0-3162-F
A9R92	0698-3161	9	1	RESISTOR 38.3K 1% .125W F TC=0+-100	24546	C4-1/8-T0-3832-F
A9R93	0698-3160	8		RESISTOR 31.6K 1% .125W F TC=0+-100	24546	C4-1/8-T0-3162-F
A9T1	9100-4453	8	1	TRANS 113B20	28480	9100-4453
A9U1	04194-81804	9	2	HIC PHASE DET	28480	04194-81804
A9U2	1826-1328	0	2	IC OP AMP LOW-NOISE DUAL 8-DIP-P PKG	28480	1826-1328
A9U3	1826-0519	9	2	IC OP AMP LOW-BIAS-H-IMPED 8-DIP-P PKG	01295	TL071CP
A9U4	1826-1328	0		IC OP AMP LOW-NOISE DUAL 8-DIP-P PKG	28480	1826-1328
A9U5	1826-0521	3	1	IC OP AMP LOW-BIAS-H-IMPED DUAL 8-DIP-P	01295	TL072CP
A9U6	04194-81804	9		HIC PHASE DET	28480	04194-81804
A9U7	1826-0519	9		IC OP AMP LOW-BIAS-H-IMPED 8-DIP-P PKG	01295	TL071CP
A9U8	1826-0081	0	1	IC OP AMP WB TO-99 PKG	27014	LM318H
A9U9	04194-81803	8	2	HIC AD	28480	04194-81803
A9U10	04194-80001	6	2	PAL 16L8A-2	28480	04194-80001
A9U11	1820-2488	3	2	IC FF TTL ALS D-TYPE POS-EDGE-TRIG	01295	SN74ALS74N
A9U12	1820-2488	3		IC FF TTL ALS D-TYPE POS-EDGE-TRIG	01295	SN74ALS74N
A9U13	1826-0138	8	1	IC COMPARATOR GP QUAD 14-DIP-P PKG	01295	LM339N
A9U14	04194-81803	8		HIC AD	28480	04194-81803
A9U15	04194-80001	6		PAL 16L8A-2	28480	04194-80001
A9U16	1820-1430	3	1	IC CNTR TTL LS BIN SYNCHRO POS-EDGE-TRIG	01295	SN74LS161AN
A9U17	1820-1194	6	1	IC CNTR TTL LS BIN UP/DOWN SYNCHRO	01295	SN74LS193N
A9U18	1820-1197	9	1	IC GATE TTL LS NAND QUAD 2-IMP	01295	SN74LS00N
A9U19	1820-1433	6	1	IC SHF-RGTR TTL LS R-S SERIAL-IN PRL-OUT	01295	SN74LS164N
A9U20	1820-1112	8	1	IC FF TTL LS D-TYPE POS-EDGE-TRIG	01295	SN74LS74AN

See introduction to this section for ordering information.
* Indicates factory selected value.

Table 6-3. Replaceable Parts (continued)

Reference Designator	HP Part Number	C D	Qty.	Description	Mfr Code	Mfr Part Number
A9W1	8159-0005	0	2	RESISTOR-ZERO OHMS 22 AWG LEAD DIA	28480	8159-0005
A9W2	8159-0005	0		RESISTOR-ZERO OHMS 22 AWG LEAD DIA	28480	8159-0005
A9XL	1252-0720	7	2	CONN DIN 96PF	28480	1252-0720
A9XR	1252-0720	7		CONN DIN 96PF	28480	1252-0720
	4040-0748	3	1	EXTR-PC BD BLK POLYC .062-BD-THKNS	28480	4040-0748
	4040-0756	3	1	EXTR-PC BD WHT POLYC .062-BD-THKNS	28480	4040-0756

See introduction to this section for ordering information.
 * Indicates factory selected value.

Table 6-3. Replaceable Parts (continued)

Reference Designator	HP Part Number	C D	Qty.	Description	Mfr Code	Mfr Part Number
A10	04194-66510	2	1	REFERENCE FREQUENCY GENERATOR BOARD ASSEMBLY	28480	04194-66510
A10C1	0121-0453	5	2	CAPACITOR-V TRMR-CER 1.3-5.4PF 200V PC-MTG	52763	304324 1.4/5.4PF N650
A10C2	0160-4792	5	2	CAPACITOR-FXD 8.2PF +- .5PF 100VDC CER	28480	0160-4792
A10C3	0160-4802	8	2	CAPACITOR-FXD 82PF +-5% 100VDC CER 0+-30	28480	0160-4802
A10C4	0180-3363	6	36	CAPACITOR-FXD 22UF+-20% 25VDC AL	28480	0180-3363
A10C5	0160-4822	2	4	CAPACITOR-FXD 1000PF +-5% 100VDC CER	28480	0160-4822
A10C6	0160-4832	4	22	CAPACITOR-FXD .01UF +-10% 100VDC CER	28480	0160-4832
A10C7	0160-4831	3	2	CAPACITOR-FXD 4700PF +-10% 100VDC CER	28480	0160-4831
A10C8	0160-3879	7	33	CAPACITOR-FXD .01UF +-20% 100VDC CER	28480	0160-3879
A10C9	0160-3879	7		CAPACITOR-FXD .01UF +-20% 100VDC CER	28480	0160-3879
A10C10	0180-3363	6		CAPACITOR-FXD 22UF+-20% 25VDC AL	28480	0180-3363
A10C11	0160-4791	4	5	CAPACITOR-FXD 10PF +-5% 100VDC CER 0+-30	28480	0160-4791
A10C12	0160-4832	4		CAPACITOR-FXD .01UF +-10% 100VDC CER	28480	0160-4832
A10C13	0160-3879	7		CAPACITOR-FXD .01UF +-20% 100VDC CER	28480	0160-3879
A10C14	0160-3879	7		CAPACITOR-FXD .01UF +-20% 100VDC CER	28480	0160-3879
A10C15	0160-4791	4		CAPACITOR-FXD 10PF +-5% 100VDC CER 0+-30	28480	0160-4791
A10C16	0160-4793	6	2	CAPACITOR-FXD 6.8PF +- .5PF 100VDC CER	28480	0160-4793
A10C17	0160-4832	4		CAPACITOR-FXD .01UF +-10% 100VDC CER	28480	0160-4832
A10C18	0160-3879	7		CAPACITOR-FXD .01UF +-20% 100VDC CER	28480	0160-3879
A10C19	0160-4832	4		CAPACITOR-FXD .01UF +-10% 100VDC CER	28480	0160-4832
A10C20	0121-0060	0	8	CAPACITOR-V TRMR-CER 2-8PF 350V PC-MTG	52763	304322 2/8PF NPO
A10C21	0160-4805	1	9	CAPACITOR-FXD 47PF +-5% 100VDC CER 0+-30	28480	0160-4805
A10C22	0121-0060	0		CAPACITOR-V TRMR-CER 2-8PF 350V PC-MTG	52763	304322 2/8PF NPO
A10C23	0160-3879	7		CAPACITOR-FXD .01UF +-20% 100VDC CER	28480	0160-3879
A10C24	0160-4832	4		CAPACITOR-FXD .01UF +-10% 100VDC CER	28480	0160-4832
A10C25	0160-3879	7		CAPACITOR-FXD .01UF +-20% 100VDC CER	28480	0160-3879
A10C26	0160-4832	4		CAPACITOR-FXD .01UF +-10% 100VDC CER	28480	0160-4832
A10C27	0160-4832	4		CAPACITOR-FXD .01UF +-10% 100VDC CER	28480	0160-4832
A10C28	0180-3363	6		CAPACITOR-FXD 22UF+-20% 25VDC AL	28480	0180-3363
A10C29	0160-4832	4		CAPACITOR-FXD .01UF +-10% 100VDC CER	28480	0160-4832
A10C30	0121-0060	0		CAPACITOR-V TRMR-CER 2-8PF 350V PC-MTG	52763	304322 2/8PF NPO
A10C31	0160-4805	1		CAPACITOR-FXD 47PF +-5% 100VDC CER 0+-30	28480	0160-4805
A10C32	0121-0060	0		CAPACITOR-V TRMR-CER 2-8PF 350V PC-MTG	52763	304322 2/8PF NPO
A10C33	0180-3363	6		CAPACITOR-FXD 22UF+-20% 25VDC AL	28480	0180-3363
A10C34	0160-3879	7		CAPACITOR-FXD .01UF +-20% 100VDC CER	28480	0160-3879
A10C35	0160-4830	2	3	CAPACITOR-FXD 2200PF +-10% 100VDC CER	28480	0160-4830
A10C36	0160-3879	7		CAPACITOR-FXD .01UF +-20% 100VDC CER	28480	0160-3879
A10C37	0160-4831	3		CAPACITOR-FXD 4700PF +-10% 100VDC CER	28480	0160-4831
A10C38	0160-4832	4		CAPACITOR-FXD .01UF +-10% 100VDC CER	28480	0160-4832
A10C39	0160-4830	2		CAPACITOR-FXD 2200PF +-10% 100VDC CER	28480	0160-4830
A10C40	0160-4822	2		CAPACITOR-FXD 1000PF +-5% 100VDC CER	28480	0160-4822
A10C41	0160-0194	3	1	CAPACITOR-FXD .015UF +-10% 200VDC POLYE	28480	0160-0194
A10C42	0180-3363	6		CAPACITOR-FXD 22UF+-20% 25VDC AL	28480	0180-3363
A10C43	0180-3363	6		CAPACITOR-FXD 22UF+-20% 25VDC AL	28480	0180-3363
A10C44	0160-3335	0	3	CAPACITOR-FXD 470PF +-10% 100VDC CER	28480	0160-3335
A10C45	0180-3363	6		CAPACITOR-FXD 22UF+-20% 25VDC AL	28480	0180-3363
A10C46	0160-4835	7	7	CAPACITOR-FXD .1UF +-10% 50VDC CER	28480	0160-4835

See introduction to this section for ordering information.
 * Indicates factory selected value.

Table 6-3. Replaceable Parts (continued)

Reference Designator	HP Part Number	C D	Qty.	Description	Mfr Code	Mfr Part Number
A10C47	0160-4805	1		CAPACITOR-FXD 47PF +-5% 100VDC CER 0+-30	28480	0160-4805
A10C48	0160-4832	4		CAPACITOR-FXD .01UF +-10% 100VDC CER	28480	0160-4832
A10C49	0160-4810	8	3	CAPACITOR-FXD 330PF +-5% 100VDC CER	28480	0160-4810
A10C50	0160-4832	4		CAPACITOR-FXD .01UF +-10% 100VDC CER	28480	0160-4832
A10C51	0160-4832	4		CAPACITOR-FXD .01UF +-10% 100VDC CER	28480	0160-4832
A10C52	0160-3879	7		CAPACITOR-FXD .01UF +-20% 100VDC CER	28480	0160-3879
A10C53	0160-3879	7		CAPACITOR-FXD .01UF +-20% 100VDC CER	28480	0160-3879
A10C54	0180-3363	6		CAPACITOR-FXD 22UF+-20% 25VDC AL	28480	0180-3363
A10C55	0160-3335	0		CAPACITOR-FXD 470PF +-10% 100VDC CER	28480	0160-3335
A10C56	0180-3363	6		CAPACITOR-FXD 22UF+-20% 25VDC AL	28480	0180-3363
A10C57	0180-3363	6		CAPACITOR-FXD 22UF+-20% 25VDC AL	28480	0180-3363
A10C58	0160-3879	7		CAPACITOR-FXD .01UF +-20% 100VDC CER	28480	0160-3879
A10C59	0180-3363	6		CAPACITOR-FXD 22UF+-20% 25VDC AL	28480	0180-3363
A10C60	0160-4832	4		CAPACITOR-FXD .01UF +-10% 100VDC CER	28480	0160-4832
A10C61	0160-4832	4		CAPACITOR-FXD .01UF +-10% 100VDC CER	28480	0160-4832
A10C62	0160-4830	2		CAPACITOR-FXD 2200PF +-10% 100VDC CER	28480	0160-4830
A10C63	0180-3363	6		CAPACITOR-FXD 22UF +-20% 25VDC AL	28480	0180-3363
A10C64	0180-3363	6		CAPACITOR-FXD 22UF +-20% 25VDC AL	28480	0180-3363
A10C65	0180-3363	6		CAPACITOR-FXD 22UF +-20% 25VDC AL	28480	0180-3363
A10C66	0180-3363	6		CAPACITOR-FXD 22UF +-20% 25VDC AL	28480	0180-3363
A10C67	0160-3879	7		CAPACITOR-FXD .01UF +-20% 100VDC CER	28480	0160-3879
A10C68	0160-3879	7		CAPACITOR-FXD .01UF +-20% 100VDC CER	28480	0160-3879
A10C69	0180-3363	6		CAPACITOR-FXD 22UF +-20% 25VDC AL	28480	0180-3363
A10C70	0180-3363	6		CAPACITOR-FXD 22UF +-20% 25VDC AL	28480	0180-3363
A10C71	0180-3363	6		CAPACITOR-FXD 22UF +-20% 25VDC AL	28480	0180-3363
A10C72	0160-4805	1		CAPACITOR-FXD 47PF +-5% 100VDC CER 0+-30	28480	0160-4805
A10C73	0160-4805	1		CAPACITOR-FXD 47PF +-5% 100VDC CER 0+-30	28480	0160-4805
A10C74	0160-4822	2		CAPACITOR-FXD 1000PF +-5% 100VDC CER	28480	0160-4822
A10C75	0160-4810	8		CAPACITOR-FXD 330PF +-5% 100VDC CER	28480	0160-4810
A10C76	0160-4810	8		CAPACITOR-FXD 330PF +-5% 100VDC CER	28480	0160-4810
A10C77	0180-3363	6		CAPACITOR-FXD 22UF+-20% 25VDC AL	28480	0180-3363
A10C78	0180-3363	6		CAPACITOR-FXD 22UF+-20% 25VDC AL	28480	0180-3363
A10C79	0180-3363	6		CAPACITOR-FXD 22UF+-20% 25VDC AL	28480	0180-3363
A10C80	0180-3363	6		CAPACITOR-FXD 22UF+-20% 25VDC AL	28480	0180-3363
A10C81	0180-3363	6		CAPACITOR-FXD 22UF+-20% 25VDC AL	28480	0180-3363
A10C82	0160-4835	7		CAPACITOR-FXD .1UF +-10% 50VDC CER	28480	0160-4835
A10C83	0160-4834	6	2	CAPACITOR-FXD .047UF +-10% 100VDC CER	28480	0160-4834
A10C84	0160-4835	7		CAPACITOR-FXD .1UF +-10% 50VDC CER	28480	0160-4835
A10C85	0180-3363	6		CAPACITOR-FXD 22UF+-20% 25VDC AL	28480	0180-3363
A10C86	0160-0127	2	1	CAPACITOR-FXD 1UF +-20% 25VDC CER	28480	0160-0127
A10C87	0180-3363	6		CAPACITOR-FXD 22UF+-20% 25VDC AL	28480	0180-3363
A10C88	0180-3363	6		CAPACITOR-FXD 22UF+-20% 25VDC AL	28480	0180-3363
A10C89	0180-3363	6		CAPACITOR-FXD 22UF+-20% 25VDC AL	28480	0180-3363
A10C90	0160-4835	7		CAPACITOR-FXD .1UF +-10% 50VDC CER	28480	0160-4835
A10C91	0180-3363	6		CAPACITOR-FXD 22UF+-20% 25VDC AL	28480	0180-3363
A10C92	0180-3363	6		CAPACITOR-FXD 22UF+-20% 25VDC AL	28480	0180-3363
A10C93	0160-3879	7		CAPACITOR-FXD .01UF +-20% 100VDC CER	28480	0160-3879
A10C94	0160-3879	7		CAPACITOR-FXD .01UF +-20% 100VDC CER	28480	0160-3879

See introduction to this section for ordering information.
 * Indicates factory selected value.

Table 6-3. Replaceable Parts (continued)

Reference Designator	HP Part Number	C D	Qty.	Description	Mfr Code	Mfr Part Number
A10C95	0160-3879	7		CAPACITOR-FXD .01UF +-20% 100VDC CER	28480	0160-3879
A10C96	0160-3879	7		CAPACITOR-FXD .01UF +-20% 100VDC CER	28480	0160-3879
A10C97	0160-3879	7		CAPACITOR-FXD .01UF +-20% 100VDC CER	28480	0160-3879
A10C98	0160-3879	7		CAPACITOR-FXD .01UF +-20% 100VDC CER	28480	0160-3879
A10C99	0160-4835	7		CAPACITOR-FXD .1UF +-10% 50VDC CER	28480	0160-4835
A10C100	0160-3335	0		CAPACITOR-FXD 470PF +-10% 100VDC CER	28480	0160-3335
A10C101	0160-4805	1		CAPACITOR-FXD 47PF +-5% 100VDC CER 0+-30	28480	0160-4805
A10C102	0180-3363	6		CAPACITOR-FXD 22UF+-20% 25VDC AL	28480	0180-3363
A10C103	0180-3363	6		CAPACITOR-FXD 22UF+-20% 25VDC AL	28480	0180-3363
A10C104	0180-3469	3	1	CAPACITOR-FXD 100UF+-20% 25VDC AL	28480	0180-3469
A10C105	0160-3879	7		CAPACITOR-FXD .01UF +-20% 100VDC CER	28480	0160-3879
A10C106	0180-3363	6		CAPACITOR-FXD 22UF+-20% 25VDC AL	28480	0180-3363
A10C107	0180-3363	6		CAPACITOR-FXD 22UF+-20% 25VDC AL	28480	0180-3363
A10C108	0160-4834	6		CAPACITOR-FXD .047UF +-10% 100VDC CER	28480	0160-4834
A10C109	0160-4802	8		CAPACITOR-FXD 82PF +-5% 100VDC CER 0+-30	28480	0160-4802
A10C110	0160-4792	5		CAPACITOR-FXD 8.2PF +- .5PF 100VDC CER	28480	0160-4792
A10C111	0160-4832	4		CAPACITOR-FXD .01UF +-10% 100VDC CER	28480	0160-4832
A10C112	0121-0453	5		CAPACITOR-V TRMR-CER 1.3-5.4PF 200V PC-MTG	52763	304324 N650
A10C113	0160-4822	2		CAPACITOR-FXD 1000PF +-5% 100VDC CER	28480	0160-4822
A10C114	0160-3879	7		CAPACITOR-FXD .01UF +-20% 100VDC CER	28480	0160-3879
A10C115	0180-3363	6		CAPACITOR-FXD 22UF+-20% 25VDC AL	28480	0180-3363
A10C116	0180-3363	6		CAPACITOR-FXD 22UF+-20% 25VDC AL	28480	0180-3363
A10C117	0160-3879	7		CAPACITOR-FXD .01UF +-20% 100VDC CER	28480	0160-3879
A10C118	0160-4805	1		CAPACITOR-FXD 47PF +-5% 100VDC CER 0+-30	28480	0160-4805
A10C119	0160-3879	7		CAPACITOR-FXD .01UF +-20% 100VDC CER	28480	0160-3879
A10C120	0160-4832	4		CAPACITOR-FXD .01UF +-10% 100VDC CER	28480	0160-4832
A10C121	0160-3879	7		CAPACITOR-FXD .01UF +-20% 100VDC CER	28480	0160-3879
A10C122	0160-3879	7		CAPACITOR-FXD .01UF +-20% 100VDC CER	28480	0160-3879
A10C123	0121-0060	0		CAPACITOR-V TRMR-CER 2-8PF 350V PC-MTG	52763	304322 2/8PF NPO
A10C124	0160-4805	1		CAPACITOR-FXD 47PF +-5% 100VDC CER 0+-30	28480	0160-4805
A10C125	0121-0060	0		CAPACITOR-V TRMR-CER 2-8PF 350V PC-MTG	52763	304322 2/8PF NPO
A10C126	0160-4832	4		CAPACITOR-FXD .01UF +-10% 100VDC CER	28480	0160-4832
A10C127	0160-3879	7		CAPACITOR-FXD .01UF +-20% 100VDC CER	28480	0160-3879
A10C128	0160-3879	7		CAPACITOR-FXD .01UF +-20% 100VDC CER	28480	0160-3879
A10C129	0160-4832	4		CAPACITOR-FXD .01UF +-10% 100VDC CER	28480	0160-4832
A10C130	0160-4793	6		CAPACITOR-FXD 6.8PF +- .5PF 100VDC CER	28480	0160-4793
A10C131	0160-4791	4		CAPACITOR-FXD 10PF +-5% 100VDC CER 0+-30	28480	0160-4791
A10C132	0160-3879	7		CAPACITOR-FXD .01UF +-20% 100VDC CER	28480	0160-3879
A10C133	0160-4832	4		CAPACITOR-FXD .01UF +-10% 100VDC CER	28480	0160-4832
A10C134	0160-4791	4		CAPACITOR-FXD 10PF +-5% 100VDC CER 0+-30	28480	0160-4791
A10C135	0160-3879	7		CAPACITOR-FXD .01UF +-20% 100VDC CER	28480	0160-3879
A10C136	0121-0060	0		CAPACITOR-V TRMR-CER 2-8PF 350V PC-MTG	52763	304322 2/8PF NPO
A10C137	0160-4805	1		CAPACITOR-FXD 47PF +-5% 100VDC CER 0+-30	28480	0160-4805
A10C138	0121-0060	0		CAPACITOR-V TRMR-CER 2-8PF 350V PC-MTG	52763	304322 2/8PF NPO
A10C139	0160-4832	4		CAPACITOR-FXD .01UF +-10% 100VDC CER	28480	0160-4832
A10C140	0160-4832	4		CAPACITOR-FXD .01UF +-10% 100VDC CER	28480	0160-4832
A10C141	0160-3879	7		CAPACITOR-FXD .01UF +-20% 100VDC CER	28480	0160-3879
A10C142	0160-3879	7		CAPACITOR-FXD .01UF +-20% 100VDC CER	28480	0160-3879
A10C143	0160-4832	4		CAPACITOR-FXD .01UF +-10% 100VDC CER	28480	0160-4832

See introduction to this section for ordering information.
* Indicates factory selected value.

Table 6-3. Replaceable Parts (continued)

Reference Designator	HP Part Number	C D	Qty.	Description	Mfr Code	Mfr Part Number
A10C144	0160-3879	7		CAPACITOR-FXD .01UF +-20% 100VDC CER	28480	0160-3879
A10C145	0180-3363	6		CAPACITOR-FXD 22UF +-20% 25VDC AL	28480	0180-3363
A10C146	0160-4835	7		CAPACITOR-FXD .1UF +-10% 50VDC CER	28480	0160-4835
A10C147	0160-4835	7		CAPACITOR-FXD .1UF +-10% 50VDC CER	28480	0160-4835
A10C148	0160-4791	4		CAPACITOR-FXD 10PF	28480	0160-4791
A10C149	0160-4790	3	1	CAPACITOR-FXD 12PF	28480	0160-4790
A10CR1	1901-0948	8	4	DIODE-SWITCHING 30V 100MA	28480	1901-0948
A10CR2	1901-0948	8		DIODE-SWITCHING 30V 100MA	28480	1901-0948
A10CR3	1901-0948	8		DIODE-SWITCHING 30V 100MA	28480	1901-0948
A10CR4	1901-0948	8		DIODE-SWITCHING 30V 100MA	28480	1901-0948
A10CR5	0122-0169	2	4	DIODE-VARACTOR	28480	0122-0169
A10CR6	0122-0169	2		DIODE-VARACTOR	28480	0122-0169
A10CR7	1902-0951	5	3	DIODE-ZNR 5.1V 5% DO-35 PD=.4W TC=+.035%	28480	1902-0951
A10CR8	1902-0956	0	2	DIODE-ZNR 8.2V 5% DO-35 PD=.4W TC=+.065%	28480	1902-0956
A10CR9	1902-0956	0		DIODE-ZNR 8.2V 5% DO-35 PD=.4W TC=+.065%	28480	1902-0956
A10CR10	1901-0518	8	3	DIODE-SM SIG SCHOTTKY	28480	1901-0518
A10CR11	1901-0518	8		DIODE-SM SIG SCHOTTKY	28480	1901-0518
A10CR12	1901-0040	1	10	DIODE-SWITCHING 30V 50MA 2NS DO-35	28480	1901-0040
A10CR13	1901-0040	1		DIODE-SWITCHING 30V 50MA 2NS DO-35	28480	1901-0040
A10CR14	1901-0040	1		DIODE-SWITCHING 30V 50MA 2NS DO-35	28480	1901-0040
A10CR15	1902-0950	4	2	DIODE-SM SIG SCHOTTKY	28480	1902-0950
A10CR16	1901-0950	4		DIODE-SM SIG SCHOTTKY	28480	1902-0950
A10CR17	1901-0040	1		DIODE-SWITCHING 30V 50MA 2NS DO-35	28480	1901-0040
A10CR18	1901-0040	1		DIODE-SWITCHING 30V 50MA 2NS DO-35	28480	1901-0040
A10CR19	1902-0951	5		DIODE-ZNR 5.1V 5% DO-35 PD=.4W TC=+.035%	28480	1902-0951
A10CR20	1901-0518	8		DIODE-SM SIG SCHOTTKY	28480	1901-0518
A10CR21	1901-0040	1		DIODE-SWITCHING 30V 50MA 2NS DO-35	28480	1901-0040
A10CR22	1902-0951	5		DIODE-ZNR 5.1V 5% DO-35 PD=.4W TC=+.035%	28480	1902-0951
A10CR23	1901-0040	1		DIODE-SWITCHING 30V 50MA 2NS DO-35	28480	1901-0040
A10CR24	1901-0040	1		DIODE-SWITCHING 30V 50MA 2NS DO-35	28480	1901-0040
A10CR25	1901-0040	1		DIODE-SWITCHING 30V 50MA 2NS DO-35	28480	1901-0040
A10CR26	1901-0040	1		DIODE-SWITCHING 30V 50MA 2NS DO-35	28480	1901-0040
A10CR27	0122-0169	2		DIODE-VARACTOR	28480	0122-0169
A10CR28	0122-0169	2		DIODE-VARACTOR	28480	0122-0169
A10DS1	1990-0665	3	1	LED-LAMP LUM-INT=1MCD IF=20MA-MAX BVR=5V	28480	1990-0665
A10E1	1906-0235	6	1	DIODE	28480	1906-0235
A10J1	1250-1810	4	1	CONNECTOR-RF SMB M PC-OHM	28480	1250-1810
A10L1	9100-2257	6	3	INDUCTOR RF-CH-MLD 820NH 10% .105DX.26LG	28480	9100-2257
A10L2	9100-2257	6		INDUCTOR RF-CH-MLD 820NH 10% .105DX.26LG	28480	9100-2257
A10L3	9140-0641	2	2	RF XFMR	28480	9140-0641
A10L4	9140-0141	7	1	INDUCTOR RF-CH-MLD 680NH 10% .105DX.26LG	28480	9140-0141
A10L5	9100-0368	6	1	INDUCTOR RF-CH-MLD 330NH 10% .105DX.26LG	28480	9100-0368
A10L6	9100-2251	0	2	INDUCTOR RF-CH-MLD 220NH 10% .105DX.26LG	28480	9100-2251
A10L7	9100-2259	8	13	INDUCTOR RF-CH-MLD 1.5UH 10% .105DX.26LG	28480	9100-2259
A10L8	9100-2247	4	5	INDUCTOR RF-CH-MLD 100NH 10% .105DX.26LG	28480	9100-2247
A10L9	9100-2247	4		INDUCTOR RF-CH-MLD 100NH 10% .105DX.26LG	28480	9100-2247
A10L10	9100-2259	8		INDUCTOR RF-CH-MLD 1.5UH 10% .105DX.26LG	28480	9100-2259
A10L11	9100-2259	8		INDUCTOR RF-CH-MLD 1.5UH 10% .105DX.26LG	28480	9100-2259
A10L12	9100-2255	4	6	INDUCTOR RF-CH-MLD 470NH 10% .105DX.26LG	28480	9100-2255

See introduction to this section for ordering information.

* Indicates factory selected value.

Table 6-3. Replaceable Parts (continued)

Reference Designator	HP Part Number	C D	Qty.	Description	Mfr Code	Mfr Part Number
A10L13	9100-2255	4		INDUCTOR RF-CH-MLD 470NH 10% .105DX.26LG	28480	9100-2255
A10L14	9100-2255	4		INDUCTOR RF-CH-MLD 470NH 10% .105DX.26LG	28480	9100-2255
A10L15	9100-2255	4		INDUCTOR RF-CH-MLD 470NH 10% .105DX.26LG	28480	9100-2255
A10L16	9100-2255	4		INDUCTOR RF-CH-MLD 470NH 10% .105DX.26LG	28480	9100-2255
A10L17	9100-2255	4		INDUCTOR RF-CH-MLD 470NH 10% .105DX.26LG	28480	9100-2255
A10L18	9100-2255	4		INDUCTOR RF-CH-MLD 470NH 10% .105DX.26LG	28480	9100-2255
A10L19	9100-2255	4		INDUCTOR RF-CH-MLD 470NH 10% .105DX.26LG	28480	9100-2255
A10L20	9140-0114	4	10	INDUCTOR RF-CH-MLD 10UH 10% .166DX.385LG	28480	9140-0114
A10L21	9100-1661	4	2	INDUCTOR RF-CH-MLD 2.2MH 5% .23DX.57LG	28480	9100-1661
A10L22	9100-1661	4		INDUCTOR RF-CH-MLD 2.2MH 5% .23DX.57LG	28480	9100-1661
A10L23	9140-0179	1	1	INDUCTOR RF-CH-MLD 22UH 10% .166DX.385LG	28480	9140-0179
A10L24	9140-0114	4		INDUCTOR RF-CH-MLD 10UH 10% .166DX.385LG	28480	9140-0114
A10L25	9100-2259	8		INDUCTOR RF-CH-MLD 1.5UH 10% .105DX.26LG	28480	9100-2259
A10L26	9100-2259	8		INDUCTOR RF-CH-MLD 1.5UH 10% .105DX.26LG	28480	9100-2259
A10L27	9140-0114	4		INDUCTOR RF-CH-MLD 10UH 10% .166DX.385LG	28480	9140-0114
A10L28	9140-0114	4		INDUCTOR RF-CH-MLD 10UH 10% .166DX.385LG	28480	9140-0114
A10L29	9140-0114	4		INDUCTOR RF-CH-MLD 10UH 10% .166DX.385LG	28480	9140-0114
A10L30	9100-2259	8		INDUCTOR RF-CH-MLD 1.5UH 10% .105DX.26LG	28480	9100-2259
A10L31	9140-0114	4		INDUCTOR RF-CH-MLD 10UH 10% .166DX.385LG	28480	9140-0114
A10L32	9100-2259	8		INDUCTOR RF-CH-MLD 1.5UH 10% .105DX.26LG	28480	9100-2259
A10L33	9140-0114	4		INDUCTOR RF-CH-MLD 10UH 10% .166DX.385LG	28480	9140-0114
A10L34	9140-0158	6	3	INDUCTOR RF-CH-MLD 1UH 10% .105DX.26LG	28480	9140-0158
A10L35	9140-0114	4		INDUCTOR RF-CH-MLD 10UH 10% .166DX.385LG	28480	9140-0114
A10L36	9140-0114	4		INDUCTOR RF-CH-MLD 10UH 10% .166DX.385LG	28480	9140-0114
A10L37	9100-2257	6	1	INDUCTOR RF-CH-MLD 8.2UH 10% .105DX.26LG	28480	9100-2257
A10L38	9100-2258	7	1	INDUCTOR RF-CH-MLD 1.2UH	28480	9100-2258
A10L39	9100-2247	4		INDUCTOR RF-CH-MLD 100NH 10% .105DX.26LG	28480	9100-2247
A10L40	9100-2251	0		INDUCTOR RF-CH-MLD 220NH 10% .105DX.26LG	28480	9100-2251
A10L41	9140-0641	2		RF XFMR	28480	9140-0641
A10L42	9100-2259	8		INDUCTOR RF-CH-MLD 1.5UH 10% .105DX.26LG	28480	9100-2259
A10L43	9140-0158	6		INDUCTOR RF-CH-MLD 1UH 10% .105DX.26LG	28480	9140-0158
A10L44	9100-2259	8		INDUCTOR RF-CH-MLD 1.5UH 10% .105DX.26LG	28480	9100-2259
A10L45	9100-2255	4		INDUCTOR RF-CH-MLD 470NH 10% .105DX.26LG	28480	9100-2255
A10L46	9100-2255	4		INDUCTOR RF-CH-MLD 470NH 10% .105DX.26LG	28480	9100-2255
A10L47	9100-2255	4		INDUCTOR RF-CH-MLD 470NH 10% .105DX.26LG	28480	9100-2255
A10L48	9100-2255	4		INDUCTOR RF-CH-MLD 470NH 10% .105DX.26LG	28480	9100-2255
A10L49	9100-2259	8		INDUCTOR RF-CH-MLD 1.5UH 10% .105DX.26LG	28480	9100-2259
A10L50	9100-2247	4		INDUCTOR RF-CH-MLD 100NH 10% .105DX.26LG	28480	9100-2247
A10L51	9100-2247	4		INDUCTOR RF-CH-MLD 100NH 10% .105DX.26LG	28480	9100-2247
A10L52	9100-2259	8		INDUCTOR RF-CH-MLD 1.5UH 10% .105DX.26LG	28480	9100-2259
A10L53	9100-2255	4		INDUCTOR RF-CH-MLD 470NH 10% .105DX.26LG	28480	9100-2255
A10L54	9100-2255	4		INDUCTOR RF-CH-MLD 470NH 10% .105DX.26LG	28480	9100-2255
A10L55	9100-2255	4		INDUCTOR RF-CH-MLD 470NH 10% .105DX.26LG	28480	9100-2255
A10L56	9100-2255	4		INDUCTOR RF-CH-MLD 470NH 10% .105DX.26LG	28480	9100-2255
A10L57	9100-2259	8		INDUCTOR RF-CH-MLD 1.5UH 10% .105DX.26LG	28480	9100-2259
A10L58	9140-0114	4		INDUCTOR RF-CH-MLD 10UH 10% .166DX.385LG	28480	9140-0114
A10L59	9100-2259	8		INDUCTOR RF-CH-MLD 1.5UH 10% .105DX.26LG	28480	9100-2259
A10Q1	1854-0130	9	4	XSTR NPN 2SC1988	28480	1854-0130
A10Q2	1854-0345	8	3	TRANSISTOR NPN 2N5179 S1 TO-72 PD=200MW	04713	2N5179

See introduction to this section for ordering information.
 * Indicates factory selected value.

Table 6-3. Replaceable Parts (continued)

Reference Designator	HP Part Number	C D	Qty.	Description	Mfr Code	Mfr Part Number
A10Q3	1854-0130	9		XSTR NPN 2SC1988	28480	1854-0130
A10Q4	1854-0810	2	1	TRANSISTOR NPN SI PD=625MW FT=200MHZ	28480	1854-0810
A10Q5	1855-0570	3	1	TRANSISTOR J-FET D-MODE TO-92 SI	28480	1855-0570
A10Q6	1853-0010	2	1	TRANSISTOR PNP SI TO-18 PD=360MW	28480	1853-0010
A10Q7	1854-0215	1	1	TRANSISTOR NPN SI PD=350MW FT=300MHZ	04713	2N3904
A10Q8	1853-0015	7	3	TRANSISTOR PNP SI PD=200MW FT=500MHZ	28480	1853-0015
A10Q9	1854-0345	8		TRANSISTOR NPN 2N5179 SI TO-72 PD=200MW	04713	2N5179
A10Q10	1854-0130	9		XSTR NPN 2SC1988	28480	1854-0130
A10Q11	1853-0015	7		TRANSISTOR PNP SI PD=200MW FT=500MHZ	28480	1853-0015
A10Q12	1854-0345	8		TRANSISTOR NPN 2N5179 SI TO-72 PD=200MW	04713	2N5179
A10Q13	1853-0015	7		TRANSISTOR PNP SI PD=200MW FT=500MHZ	28480	1853-0015
A10Q14	1854-0130	9		XSTR NPN 2SC1988	28480	1854-0130
A10R1	0757-1094	9	5	RESISTOR 1.47K 1% .125W F TC=0+-100	24546	C4-1/8-T0-1471-F
A10R2	0757-0438	3	2	RESISTOR 5.11K 1% .125W F TC=0+-100	24546	C4-1/8-T0-5111-F
A10R3	0757-1094	9		RESISTOR 1.47K 1% .125W F TC=0+-100	24546	C4-1/8-T0-1471-F
A10R4	0757-0439	4	6	RESISTOR 6.81K 1% .125W F TC=0+-100	24546	C4-1/8-T0-6811-F
A10R5	0698-3447	4	3	RESISTOR 422 1% .125W F TC=0+-100	24546	C4-1/8-T0-422R-F
A10R6	0757-0439	4		RESISTOR 6.81K 1% .125W F TC=0+-100	24546	C4-1/8-T0-6811-F
A10R7	0698-0084	9	7	RESISTOR 2.15K 1% .125W F TC=0+-100	24546	C4-1/8-T0-2151-F
A10R8	0698-3153	9	4	RESISTOR 3.83K 1% .125W F TC=0+-100	24546	C4-1/8-T0-3831-F
A10R9	0757-0442	9	10	RESISTOR 10K 1% .125W F TC=0+-100	24546	C4-1/8-T0-1002-F
A10R10	0757-0442	9		RESISTOR 10K 1% .125W F TC=0+-100	24546	C4-1/8-T0-1002-F
A10R11	0757-0294	9	6	RESISTOR 17.8 1% .125W F TC=0+-100	19701	MF4C1/8-T0-17R8-F
A10R12	0698-3132	4	9	RESISTOR 261 1% .125W F TC=0+-100	24546	C4-1/8-T0-2610-F
A10R13	0757-0441	8	2	RESISTOR 8.25K 1% .125W F TC=0+-100	24546	C4-1/8-T0-8251-F
A10R14	0757-0401	0	9	RESISTOR 100 1% .125W F TC=0+-100	24546	C4-1/8-T0-101-F
A10R15	0757-0397	3	5	RESISTOR 68.1 1% .125W F TC=0+-100	24546	C4-1/8-T0-68R1-F
A10R16	0757-0401	0		RESISTOR 100 1% .125W F TC=0+-100	24546	C4-1/8-T0-101-F
A10R17	0698-3132	4		RESISTOR 261 1% .125W F TC=0+-100	24546	C4-1/8-T0-2610-F
A10R18	0757-0439	4		RESISTOR 6.81K 1% .125W F TC=0+-100	24546	C4-1/8-T0-6811-F
A10R19	0757-0424	7	2	RESISTOR 1.1K 1% .125W F TC=0+-100	24546	C4-1/8-T0-1101-F
A10R20	0757-0395	1	4	RESISTOR 56.2 1% .125W F TC=0+-100	24546	C4-1/8-T0-56R2-F
A10R21	0698-3447	4		RESISTOR 422 1% .125W F TC=0+-100	24546	C4-1/8-T0-422R-F
A10R22	0698-3438	3	2	RESISTOR 147 1% .125W F TC=0+-100	24546	C4-1/8-T0-147R-F
A10R23	0757-0401	0		RESISTOR 100 1% .125W F TC=0+-100	24546	C4-1/8-T0-101-F
A10R24	0757-0399	5	7	RESISTOR 82.5 1% .125W F TC=0+-100	24546	C4-1/8-T0-82R5-F
A10R25	2100-0554	5	1	RESISTOR-TRMR 500 10% C TOP-ADJ 1-TRN	28480	2100-0554
A10R26	0757-0399	5		RESISTOR 82.5 1% .125W F TC=0+-100	24546	C4-1/8-T0-82R5-F
A10R27	0698-4037	0	10	RESISTOR 46.4 1% .125W F TC=0+-100	24546	C4-1/8-T0-46R4-F
A10R28	0698-3438	3		RESISTOR 147 1% .125W F TC=0+-100	24546	C4-1/8-T0-147R-F
A10R29	0698-3447	4		RESISTOR 422 1% .125W F TC=0+-100	24546	C4-1/8-T0-422R-F
A10R30	0757-0395	1		RESISTOR 56.2 1% .125W F TC=0+-100	24546	C4-1/8-T0-56R2-F
A10R31	0757-0401	0		RESISTOR 100 1% .125W F TC=0+-100	24546	C4-1/8-T0-101-F
A10R32	0698-3132	4		RESISTOR 261 1% .125W F TC=0+-100	24546	C4-1/8-T0-2610-F
A10R33	0757-0294	9		RESISTOR 17.8 1% .125W F TC=0+-100	19701	MF4C1/8-T0-17R8-F
A10R34	0698-3132	4		RESISTOR 261 1% .125W F TC=0+-100	24546	C4-1/8-T0-2610-F
A10R35	0757-1094	9		RESISTOR 1.47K 1% .125W F TC=0+-100	24546	C4-1/8-T0-1471-F
A10R36	0757-0280	3	15	RESISTOR 1K 1% .125W F TC=0+-100	24546	C4-1/8-T0-1001-F
A10R37	0757-0280	3		RESISTOR 1K 1% .125W F TC=0+-100	24546	C4-1/8-T0-1001-F

See introduction to this section for ordering information.
* Indicates factory selected value.

Table 6-3. Replaceable Parts (continued)

Reference Designator	HP Part Number	C D	Qty.	Description	Mfr Code	Mfr Part Number
A10R38	0757-0280	3		RESISTOR 1K 1% .125W F TC=0+-100	24546	C4-1/8-T0-1001-F
A10R39	0757-0417	8	1	RESISTOR 562 1% .125W F TC=0+-100	24546	C4-1/8-T0-562R-F
A10R40	0757-0442	9		RESISTOR 10K 1% .125W F TC=0+-100	24546	C4-1/8-T0-1002-F
A10R41	0757-0279	0	4	RESISTOR 3.16K 1% .125W F TC=0+-100	24546	C4-1/8-T0-3161-F
A10R42	0757-0279	0		RESISTOR 3.16K 1% .125W F TC=0+-100	24546	C4-1/8-T0-3161-F
A10R43	0698-3266	5	2	RESISTOR 237K 1% .125W F TC=0+-100	24546	C4-1/8-T0-2373-F
A10R44	0698-3266	5		RESISTOR 237K 1% .125W F TC=0+-100	24546	C4-1/8-T0-2373-F
A10R45	0757-0428	1	2	RESISTOR 1.62K 1% .125W F TC=0+-100	24546	C4-1/8-T0-1621-F
A10R46	0757-0440	7	1	RESISTOR 7.5K 1% .125W F TC=0+-100	24546	C4-1/8-T0-7501-F
A10R47	0757-0278	9	2	RESISTOR 1.78K 1% .125W F TC=+-100	28586	C4-1/8-T0-1781-F
A10R48	0757-0200	7	3	RESISTOR 5.62K 1% .125W F TC=0+-100	24546	C4-1/8-T0-5621-F
A10R49	0757-0439	4		RESISTOR 6.81K 1% .125W F TC=0+-100	24546	C4-1/8-T0-6811-F
A10R50	0757-0200	7		RESISTOR 5.62K 1% .125W F TC=0+-100	24546	C4-1/8-T0-5621-F
A10R51	0757-0280	3		RESISTOR 1K 1% .125W F TC=0+-100	24546	C4-1/8-T0-1001-F
A10R52				NOT ASSIGNED		
A10R53	0698-3156	2	3	RESISTOR 14.7K 1% .125W F TC=0+-100		
A10R54				NOT ASSIGNED		
A10R55	0698-3156	2		RESISTOR 14.7K 1% .125W F TC=0+-100		
A10R56	0757-0439	4		RESISTOR 6.81K 1% .125W F TC=0+-100	24546	C4-1/8-T0-6811-F
A10R57	0757-0280	3		RESISTOR 1K 1% .125W F TC=0+-100	24546	C4-1/8-T0-1001-F
A10R58	0698-3154	0	1	RESISTOR 4.22K 1% .125W F TC=0+-100	24546	C4-1/8-T0-4221-F
A10R59	0698-3444	1	2	RESISTOR 316 1% .125W F TC=0+-100	24546	C4-1/8-T0-316R-F
A10R60	0757-0399	5		RESISTOR 82.5 1% .125W F TC=0+-100	24546	C4-1/8-T0-82R5-F
A10R61	0757-0401	0		RESISTOR 100 1% .125W F TC=0+-100	24546	C4-1/8-T0-101-F
A10R62	0757-0399	5		RESISTOR 82.5 1% .125W F TC=0+-100	24546	C4-1/8-T0-82R5-F
A10R63	0757-1094	9		RESISTOR 1.47K 1% .125W F TC=0+-100	24546	C4-1/8-T0-1471-F
A10R64	0698-4037	0		RESISTOR 46.4 1% .125W F TC=0+-100	24546	C4-1/8-T0-46R4-F
A10R65	0757-0280	3		RESISTOR 1K 1% .125W F TC=0+-100	24546	C4-1/8-T0-1001-F
A10R66	0757-0280	3		RESISTOR 1K 1% .125W F TC=0+-100	24546	C4-1/8-T0-1001-F
A10R67	0757-0280	3		RESISTOR 1K 1% .125W F TC=0+-100	24546	C4-1/8-T0-1001-F
A10R68	0757-0280	3		RESISTOR 1K 1% .125W F TC=0+-100	24546	C4-1/8-T0-1001-F
A10R69	0698-4037	0		RESISTOR 46.4 1% .125W F TC=0+-100	24546	C4-1/8-T0-46R4-F
A10R70	0757-0395	1		RESISTOR 56.2 1% .125W F TC=0+-100	24546	C4-1/8-T0-56R2-F
A10R71	0698-4037	0		RESISTOR 46.4 1% .125W F TC=0+-100	24546	C4-1/8-T0-46R4-F
A10R72	2100-3353	8	1	RESISTOR-TRMR 20K 10% C SIDE-ADJ 1-TRN	28480	2100-3353
A10R73	0698-4037	0		RESISTOR 46.4 1% .125W F TC=0+-100	24546	C4-1/8-T0-46R4-F
A10R74	0757-0428	1		RESISTOR 1.62K 1% .125W F TC=0+-100	24546	C4-1/8-T0-1621-F
A10R75	0757-0279	0		RESISTOR 3.16K 1% .125W F TC=0+-100	24546	C4-1/8-T0-3161-F
A10R76	0698-0084	9		RESISTOR 2.15K 1% .125W F TC=0+-100	24546	C4-1/8-T0-2151-F
A10R77	0757-0279	0		RESISTOR 3.16K 1% .125W F TC=0+-100	24546	C4-1/8-T0-3161-F
A10R78	0757-0199	3	1	RESISTOR 21.5K 1% .125W F TC=0+-100	24546	C4-1/8-T0-2152-F
A10R79	0698-0082	7	1	RESISTOR 464 1% .125W F TC=0+-100	24546	C4-1/8-T0-4640-F
A10R80	0757-0461	2	1	RESISTOR 68.1K 1% .125W F TC=0+-100	24546	C4-1/8-T0-6812-F
A10R81	0757-0442	9		RESISTOR 10K 1% .125W F TC=0+-100	24546	C4-1/8-T0-1002-F
A10R82	0757-0280	3		RESISTOR 1K 1% .125W F TC=0+-100	24546	C4-1/8-T0-1001-F
A10R83	0757-0442	9		RESISTOR 10K 1% .125W F TC=0+-100	24546	C4-1/8-T0-1002-F
A10R84	0698-3155	1	2	RESISTOR 4.64K 1% .125W F TC=0+-100	24546	C4-1/8-T0-4641-F
A10R85	0757-0442	9		RESISTOR 10K 1% .125W F TC=0+-100	24546	C4-1/8-T0-1002-F
A10R86	0698-0084	9		RESISTOR 2.15K 1% .125W F TC=0+-100	24546	C4-1/8-T0-2151-F

See introduction to this section for ordering information.
 * Indicates factory selected value.

Table 6-3. Replaceable Parts (continued)

Reference Designator	HP Part Number	C D	Qty.	Description	Mfr Code	Mfr Part Number
A10R87	0698-0084	9		RESISTOR 2.15K 1% .125W F TC=0+-100	24546	C4-1/8-T0-2151-F
A10R88	0757-0401	0		RESISTOR 100 1% .125W F TC=0+-100	24546	C4-1/8-T0-101-F
A10R89	0757-0397	3		RESISTOR 68.1 1% .125W F TC=0+-100	24546	C4-1/8-T0-68R1-F
A10R90	0757-0280	3		RESISTOR 1K 1% .125W F TC=0+-100	24546	C4-1/8-T0-1001-F
A10R91	0757-0280	3		RESISTOR 1K 1% .125W F TC=0+-100	24546	C4-1/8-T0-1001-F
A10R92	0757-0442	9		RESISTOR 10K 1% .125W F TC=0+-100	24546	C4-1/8-T0-1002-F
A10R93	0757-0442	9		RESISTOR 10K 1% .125W F TC=0+-100	24546	C4-1/8-T0-1002-F
A10R94	0757-1094	9		RESISTOR 1.47K 1% .125W F TC=0+-100	24546	C4-1/8-T0-1471-F
A10R95	0757-0280	3		RESISTOR 1K 1% .125W F TC=0+-100	24546	C4-1/8-T0-1001-F
A10R96	0757-0399	5		RESISTOR 82.5 1% .125W F TC=0+-100	24546	C4-1/8-T0-82R5-F
A10R97	0698-4037	0		RESISTOR 46.4 1% .125W F TC=0+-100	24546	C4-1/8-T0-46R4-F
A10R98	0757-0401	0		RESISTOR 100 1% .125W F TC=0+-100	24546	C4-1/8-T0-101-F
A10R99	0757-0280	3		RESISTOR 1K 1% .125W F TC=0+-100	24546	C4-1/8-T0-1001-F
A10R100	0757-0442	9		RESISTOR 10K 1% .125W F TC=0+-100	24546	C4-1/8-T0-1002-F
A10R101	0757-0442	9		RESISTOR 10K 1% .125W F TC=0+-100	24546	C4-1/8-T0-1002-F
A10R102	0698-3156	2		RESISTOR 14.7K 1% .125W F TC=0+-100	24546	C4-1/8-T0-1472-F
A10R103	0757-0280	3		RESISTOR 1K 1% .125W F TC=0+-100	24546	C4-1/8-T0-1001-F
A10R104	0757-0278	9		RESISTOR 1.78K 1% .125W F TC=0+-100	24546	C4-1/8-T0-1781-F
A10R105	0757-0274	5	1	RESISTOR 1.21K 1% .125W F TC=0+-100	24546	C4-1/8-T0-1211-F
A10R106	0698-3444	1		RESISTOR 316 1% .125W F TC=0+-100	24546	C4-1/8-T0-316R-F
A10R107	0757-0200	7		RESISTOR 5.62K 1% .125W F TC=0+-100	24546	C4-1/8-T0-5621-F
A10R108	0698-3153	9		RESISTOR 3.83K 1% .125W F TC=0+-100	24546	C4-1/8-T0-3831-F
A10R109	0698-4037	0		RESISTOR 46.4 1% .125W F TC=0+-100	24546	C4-1/8-T0-46R4-F
A10R110	0698-4037	0		RESISTOR 46.4 1% .125W F TC=0+-100	24546	C4-1/8-T0-46R4-F
A10R111	0757-0399	5		RESISTOR 82.5 1% .125W F TC=0+-100	24546	C4-1/8-T0-82R5-F
A10R112	0698-0084	9		RESISTOR 2.15K 1% .125W F TC=0+-100	24546	C4-1/8-T0-2151-F
A10R113	0698-3155	1		RESISTOR 4.64K 1% .125W F TC=0+-100	24546	C4-1/8-T0-4641-F
A10R114	0757-0438	3		RESISTOR 5.11K 1% .125W F TC=0+-100	24546	C4-1/8-T0-5111-F
A10R115	0698-3132	4		RESISTOR 261 1% .125W F TC=0+-100	24546	C4-1/8-T0-2610-F
A10R116	0757-0294	9		RESISTOR 17.8 1% .125W F TC=0+-100	19701	MF4C1/8-T0-17R8-F
A10R117	0698-3132	4		RESISTOR 261 1% .125W F TC=0+-100	24546	C4-1/8-T0-2610-F
A10R118	0698-3441	8	2	RESISTOR 215 1% .125W F TC=0+-100	24546	C4-1/8-T0-215R-F
A10R119	0698-4037	0		RESISTOR 46.4 1% .125W F TC=0+-100	24546	C4-1/8-T0-46R4-F
A10R120	0757-0401	0		RESISTOR 100 1% .125W F TC=0+-100	24546	C4-1/8-T0-101-F
A10R121	0757-0397	3		RESISTOR 68.1 1% .125W F TC=0+-100	24546	C4-1/8-T0-68R1-F
A10R122	0757-0401	0		RESISTOR 100 1% .125W F TC=0+-100	24546	C4-1/8-T0-101-F
A10R123	0757-0441	8		RESISTOR 8.25K 1% .125W F TC=0+-100	24546	C4-1/8-T0-8251-F
A10R124	0757-0439	4		RESISTOR 6.81K 1% .125W F TC=0+-100	24546	C4-1/8-T0-6811-F
A10R125	0757-0424	7		RESISTOR 1.1K 1% .125W F TC=0+-100	24546	C4-1/8-T0-1101-F
A10R126	0757-0294	9		RESISTOR 17.8 1% .125W F TC=0+-100	19701	MF4C1/8-T0-17R8-F
A10R127	0757-0294	9		RESISTOR 17.8 1% .125W F TC=0+-100	19701	MF4C1/8-T0-17R8-F
A10R128	0757-0294	9		RESISTOR 17.8 1% .125W F TC=0+-100	19701	MF4C1/8-T0-17R8-F
A10R129	0698-3132	4		RESISTOR 261 1% .125W F TC=0+-100	24546	C4-1/8-T0-2610-F
A10R130	0698-3132	4		RESISTOR 261 1% .125W F TC=0+-100	24546	C4-1/8-T0-2610-F
A10R131	0698-3132	4		RESISTOR 261 1% .125W F TC=0+-100	24546	C4-1/8-T0-2610-F
A10R132	0757-0399	5		RESISTOR 82.5 1% .125W F TC=0+-100	24546	C4-1/8-T0-82R5-F
A10R133	0757-0395	1		RESISTOR 56.2 1% .125W F TC=0+-100	24546	C4-1/8-T0-56R2-F
A10R134	0698-4037	0		RESISTOR 46.4 1% .125W F TC=0+-100	24546	C4-1/8-T0-46R4-F
A10R135	0757-0397	3		RESISTOR 68.1 1% .125W F TC=0+-100	24546	C4-1/8-T0-68R1-F

See introduction to this section for ordering information.
 * Indicates factory selected value.

Table 6-3. Replaceable Parts (continued)

Reference Designator	HP Part Number	C D	Qty.	Description	Mfr Code	Mfr Part Number
A10R136	0698-3441	8		RESISTOR 215 1% .125W F TC=0+-100	24546	C4-1/8-T0-215R-F
A10R137	0757-0397	3		RESISTOR 68.1 1% .125W F TC=0+-100	24546	C4-1/8-T0-68R1-F
A10TP1	0360-1653	5	9	CONNECTOR-SGL CONT PIN .045-IN-BSC-SZ SQ	28480	0360-1653
A10TP2	0360-1653	5		CONNECTOR-SGL CONT PIN .045-IN-BSC-SZ SQ	28480	0360-1653
A10TP3	0360-0535	0	5	TERMINAL TEST POINT PCB	00000	ORDER BY DESCRIPT.
A10TP4	0360-1653	5		CONNECTOR-SGL CONT PIN .045-IN-BSC-SZ SQ	28480	0360-1653
A10TP5	0360-1653	5		CONNECTOR-SGL CONT PIN .045-IN-BSC-SZ SQ	28480	0360-1653
A10TP6	0360-0535	0		TERMINAL TEST POINT PCB	00000	ORDER BY DESCRIPT.
A10TP7	0360-0535	0		TERMINAL TEST POINT PCB	00000	ORDER BY DESCRIPT.
A10TP8	0360-0535	0		TERMINAL TEST POINT PCB	00000	ORDER BY DESCRIPT.
A10TP9	0360-1653	5		CONNECTOR-SGL CONT PIN .045-IN-BSC-SZ SQ	28480	0360-1653
A10TP10	0360-1653	5		CONNECTOR-SGL CONT PIN .045-IN-BSC-SZ SQ	28480	0360-1653
A10TP11	0360-1653	5		CONNECTOR-SGL CONT PIN .045-IN-BSC-SZ SQ	28480	0360-1653
A10TP12	0360-1653	5		CONNECTOR-SGL CONT PIN .045-IN-BSC-SZ SQ	28480	0360-1653
A10TP13	0360-1653	5		CONNECTOR-SGL CONT PIN .045-IN-BSC-SZ SQ	28480	0360-1653
A10TP14	0360-0535	0		TERMINAL TEST POINT PCB	00000	ORDER BY DESCRIPT.
A10U1	1826-1310	0	3	IC RF/IF AMPL WB 4-DIP-P PKG	28480	1826-1310
A10U2	1826-1311	1	4	IC RF/IF AMPL WB 4-DIP-P PKG	28480	1826-1311
A10U3	1826-1310	0		IC RF/IF AMPL WB 4-DIP-P PKG	28480	1826-1310
A10U4	1820-1246	9	1	IC GATE TTL LS AND QUAD 2-INP	01295	SN74LS09N
A10U5	1826-0139	9	2	IC OP AMP GP DUAL 8-DIP-P PKG	3L585	CA1458G
A10U6	1826-1328	0	2	IC OP AMP LOW-NOISE DUAL 8-DIP-P PKG	28480	1826-1328
A10U7	1820-2691	0	4	IC FF TTL F D-TYPE POS-EDGE-TRIG	07263	74F74PC
A10U8	1820-1416	5	1	IC SCHMITT-TRIG TTL LS INV HEX 1-INP	01295	SN74LS14N
A10U9	1826-1311	1		IC RF/IF AMPL WB 4-DIP-P PKG	28480	1826-1311
A10U10	1826-1310	0		IC RF/IF AMPL WB 4-DIP-P PKG	28480	1826-1310
A10U11	1826-1328	0		IC OP AMP LOW-NOISE DUAL 8-DIP-P PKG	28480	1826-1328
A10U12	1820-1199	1	2	IC INV TTL LS HEX 1-INP	01295	SN74LS04N
A10U13	1826-0139	9		IC OP AMP GP DUAL 8-DIP-P PKG	3L585	CA1458G
A10U14	1820-1429	0	3	IC CNTR TTL LS DECD SYNCHRO	01295	SN74LS160AN
A10U15	1820-1430	3	1	IC CNTR TTL LS BIN SYNCHRO POS-EDGE-TRIG	01295	SN74LS161AN
A10U16	1820-1199	1		IC INV TTL LS HEX 1-INP	01295	SN74LS04N
A10U17	1820-1112	8	1	IC FF TTL LS D-TYPE POS-EDGE-TRIG	01295	SN74LS74AN
A10U18	1820-1433	6	1	IC SHF-RGTR TTL LS R-S SERIAL-IN PRL-OUT	01295	SN74LS164N
A10U19	1820-2691	0		IC FF TTL F D-TYPE POS-EDGE-TRIG	07263	74F74PC
A10U20	1820-2691	0		IC FF TTL F D-TYPE POS-EDGE-TRIG	07263	74F74PC
A10U21	1820-1074	1	1	IC DRVR TTL NOR QUAD 2-INP	01295	SN74128N
A10U22	1820-1429	0		IC CNTR TTL LS DECD SYNCHRO	01295	SN74LS160AN
A10U23	1820-1429	0		IC CNTR TTL LS DECD SYNCHRO	01295	SN74LS160AN
A10U24	1820-2691	0		IC FF TTL F D-TYPE POS-EDGE-TRIG	07263	74F74PC
A10U25	1826-1311	1		IC RF/IF AMPL WB 4-DIP-P PKG	28480	1826-1311
A10U26	1826-1311	1		IC RF/IF AMPL WB 4-DIP-P PKG	28480	1826-1311
A10XL	1252-0720	7	2	CONN DIN 96PF	28480	1252-0720
A10XR	1252-0720	7		CONN DIN 96PF	28480	1252-0720
A10Y1	0410-1575	7	1	XTAL 79.9219MHZ	28480	0410-1575
A10Y2	0410-1576	8	1	XTAL 79.9306MHZ	28480	0410-1576
A10Y3	0410-1574	6	1	XTAL 80.0000MHZ	28480	0410-1574
	4040-0749	3	1	EXTR-PC BD BLK POLYC.062-BD-THKNS	28480	4040-0748
	4040-0749	4	1	EXTR-PC BD BLK POLYC .062-BD-THKNS	28480	4040-0749

See introduction to this section for ordering information.
* Indicates factory selected value.

Table 6-3. Replaceable Parts

Reference Designator	HP Part Number	C D	Qty.	Description	Mfr Code	Mfr Part Number
A11	04194-66511	3	1	FRACTIONAL N LOOP BOARD ASSEMBLY	28480	04194-66511
A11C1	0180-3598	9	4	CAPACITOR-FXD 33UF+-20% 100VDC AL	28480	0180-3598
A11C2	0180-3598	9		CAPACITOR-FXD 33UF+-20% 100VDC AL	28480	0180-3598
A11C3	0160-4832	4		CAPACITOR-FXD .01UF +-10% 100VDC CER	28480	0160-4832
A11C4	0160-2251	7	1	CAPACITOR-FXD 5.6PF +- .25PF 500VDC CER	28480	0160-2251
A11C5	0180-3469	3	7	CAPACITOR-FXD 100UF+-20% 25VDC AL	28480	0180-3469
A11C6	0180-1085	5	1	CAPACITOR-FXD 4.7UF 16VDC TA	28480	0180-1085
A11C7	0160-4832	4		CAPACITOR-FXD .01UF +-10% 100VDC CER	28480	0160-4832
A11C8	0160-4801	7	2	CAPACITOR-FXD 100PF +-5% 100VDC CER	28480	0160-4801
A11C9	0160-4832	4		CAPACITOR-FXD .01UF +-10% 100VDC CER	28480	0160-4832
A11C10	0160-4791	4	1	CAPACITOR-FXD 10PF +-5% 100VDC CER 0+-30	28480	0160-4791
A11C11	0160-4832	4	24	CAPACITOR-FXD .01UF +-10% 100VDC CER	28480	0160-4832
A11C12	0160-6338	9	1	CAP 0.027UF	28480	0160-6338
A11C13	0160-2940	1	1	CAPACITOR-FXD 470PF +-5% 300VDC MICA	28480	0160-2940
A11C14	0160-2208	4	1	CAPACITOR-FXD 330PF +-5% 300VDC MICA	28480	0160-2208
A11C15	0180-3469	3		CAPACITOR-FXD 100UF+-20% 25VDC AL	28480	0180-3469
A11C16	0180-3469	3		CAPACITOR-FXD 100UF+-20% 25VDC AL	28480	0180-3469
A11C17				NOT ASSIGNED		
A11C18	0160-2204	0	2	CAPACITOR-FXD 100PF +-5% 300VDC MICA	28480	0160-2204
A11C19	0160-2204	0		CAPACITOR-FXD 100PF +-5% 300VDC MICA	28480	0160-2204
A11C20	0160-4832	4		CAPACITOR-FXD .01UF +-10% 100VDC CER	28480	0160-4832
A11C21	0180-3470	6	2	CAPACITOR-FXD 220UF+-20% 25VDC AL	28480	0180-3470
A11C22	0180-3470	6		CAPACITOR-FXD 220UF+-20% 25VDC AL	28480	0180-3470
A11C23	0160-4832	4		CAPACITOR-FXD .01UF +-10% 100VDC CER	28480	0160-4832
A11C24	0160-4825	5	1	CAPACITOR-FXD 560PF +-5% 100VDC CER	28480	0160-4825
A11C25	0160-2257	3	1	CAPACITOR-FXD 10PF +-5% 500VDC CER 0+-60	28480	0160-2257
A11C26	0180-0228	6	2	CAPACITOR-FXD 22UF+-10% 15VDC TA	56289	150D226X9015B2
A11C27	0160-4822	2	3	CAPACITOR-FXD 1000PF +-5% 100VDC CER	28480	0160-4822
A11C28	0160-4814	2	6	CAPACITOR-FXD 150PF +-5% 100VDC CER	28480	0160-4814
A11C29	0160-6336	7	2	CAP 2200PF	28480	0160-6336
A11C30	0160-4814	2		CAPACITOR-FXD 150PF +-5% 100VDC CER	28480	0160-4814
A11C31	0160-6336	7		CAP 2200PF	28480	0160-6336
A11C32	0160-6337	8	1	CAP 5600PF	28480	0160-6337
A11C33	0160-4824	4	1	CAPACITOR-FXD 680PF +-5% 100VDC CER	28480	0160-4824
A11C34	0160-2250	6	1	CAPACITOR-FXD 5.1PF +- .25PF 500VDC CER	28480	0160-2250
A11C35	0160-4832	4		CAPACITOR-FXD .01UF +-10% 100VDC CER	28480	0160-4832
A11C36	0160-4832	4		CAPACITOR-FXD .01UF +-10% 100VDC CER	28480	0160-4832
A11C37	0160-0210	8	1	CAPACITOR-FXD 270PF +-5%	28480	0160-0210
A11C38	0160-4832	4		CAPACITOR-FXD .01UF +-10% 100VDC CER	28480	0160-4832
A11C39	0180-3363	6	2	CAPACITOR-FXD 22UF+-20% 25VDC AL	28480	0180-3363
A11C40	0160-6339	0	1	CAP 0.12UF	28480	0160-6339
A11C41	0160-4822	2	21	CAPACITOR-FXD 1000PF +-5% 100VDC CER	28480	0160-4822
A11C42	0160-4832	4		CAPACITOR-FXD .01UF +-10% 100VDC CER	28480	0160-4832
A11C43	0160-4832	4		CAPACITOR-FXD .01UF +-10% 100VDC CER	28480	0160-4832
A11C44	0160-4832	4		CAPACITOR-FXD .01UF +-10% 100VDC CER	28480	0160-4832
A11C45	0180-3363	6		CAPACITOR-FXD 22UF +-20% 25VDC AL	28480	0180-3363
A11C46	0160-4832	4		CAPACITOR-FXD .01UF +-10% 100VDC CER	28480	0160-4832
A11C47	0160-2222	2	1	CAPACITOR-FXD 1500PF +-5% 300VDC MICA	28480	0160-2222

See introduction to this section for ordering information.
 * Indicates factory selected value.

Table 6-3. Replaceable Parts (continued)

Reference Designator	HP Part Number	C D	Qty.	Description	Mfr Code	Mfr Part Number
A11C48	0160-4835	7	5	CAPACITOR-FXD .1UF +-10% 50VDC CER	28480	0160-4835
A11C49	0160-4832	4		CAPACITOR-FXD .01UF +-10% 100VDC CER	28480	0160-4832
A11C50	0180-0229	7	2	CAPACITOR-FXD 33UF +-10% 10VDC TA	56289	150D336X9010B2
A11C51	0160-4832	4		CAPACITOR-FXD .01UF +-10% 100VDC CER	28480	0160-4832
A11C52	0160-4832	4		CAPACITOR-FXD .01UF +-10% 100VDC CER	28480	0160-4832
A11C53				NOT ASSIGNED		
A11C54	0160-3877	5	1	CAPACITOR-FXD 100PF	28480	0160-3877
A11C55	0160-3879	7	4	CAPACITOR-FXD .01UF +-20% 100VDC CER	28480	0160-3879
A11C56	0160-3879	7		CAPACITOR-FXD .01UF +-20% 100VDC CER	28480	0160-3879
A11C57	0160-4814	2		CAPACITOR-FXD 150PF +-5% 100VDC CER	28480	0160-4814
A11C58	0160-4804	0	2	CAPACITOR-FXD 56PF +-5% 100VDC CER 0+-30	28480	0160-4804
A11C59	0160-0127	2	1	CAPACITOR-FXD 1UF +-20% 25VDC CER	28480	0160-0127
A11C60	0160-4835	7		CAPACITOR-FXD .1UF +-10% 50VDC CER	28480	0160-4835
A11C61	0160-4381	8	1	CAPACITOR-FXD 1.5PF +- .25PF 200VDC CER	28480	0160-4381
A11C62	0160-3874	2	1	CAPACITOR-FXD 10PF +- .5PF 200VDC CER	28480	0160-3874
A11C63	0180-3469	3		CAPACITOR-FXD 100UF+-20% 25VDC AL	28480	0180-3469
A11C64	0160-4804	0		CAPACITOR-FXD 56PF +-5% 100VDC CER 0+-30	28480	0160-4804
A11C65	0160-4832	4		CAPACITOR-FXD .01UF +-10% 100VDC CER	28480	0160-4832
A11C66	0180-0229	7		CAPACITOR-FXD 33UF +-10% 10VDC TA	56289	150D336X9010B2
A11C67	0180-0228	6		CAPACITOR-FXD 22UF +-10% 15VDC TA	56289	150D226X9015B2
A11C68	0140-0191	8	1	CAPACITOR-FXD 56PF +-5% 300VDC MICA	72136	DM15E560J0300WV1CR
A11C69	0160-4832	4		CAPACITOR-FXD .01UF +-10% 100VDC CER	28480	0160-4832
A11C70	0160-4832	4		CAPACITOR-FXD .01UF +-10% 100VDC CER	28480	0160-4832
A11C71	0160-4832	4		CAPACITOR-FXD .01UF +-10% 100VDC CER	28480	0160-4832
A11C72	0160-4835	7		CAPACITOR-FXD .1UF +-10% 50VDC CER	28480	0160-4835
A11C73	0160-4832	4		CAPACITOR-FXD .01UF +-10% 100VDC CER	28480	0160-4832
A11C74	0160-4832	4		CAPACITOR-FXD .01UF +-10% 100VDC CER	28480	0160-4832
A11C75	0160-4822	2		CAPACITOR-FXD 1000PF +-5% 100VDC CER	28480	0160-4822
A11C76	0160-4796	9	1	CAPACITOR-FXD 3.9PF +- .25PF 100VDC CER	28480	0160-4796
A11C77	0160-4805	1	1	CAPACITOR-FXD 47PF +-5% 100VDC CER 0+-30	28480	0160-4805
A11C78	0160-4832	4		CAPACITOR-FXD .01UF +-10% 100VDC CER	28480	0160-4832
A11C79	0160-4822	2		CAPACITOR-FXD 1000PF +-5% 100VDC CER	28480	0160-4822
A11C80	0160-4822	2		CAPACITOR-FXD 1000PF +-5% 100VDC CER	28480	0160-4822
A11C81	0160-4822	2		CAPACITOR-FXD 1000PF +-5% 100VDC CER	28480	0160-4822
A11C82	0160-4822	2		CAPACITOR-FXD 1000PF +-5% 100VDC CER	28480	0160-4822
A11C83	0160-4822	2		CAPACITOR-FXD 1000PF +-5% 100VDC CER	28480	0160-4822
A11C84	0160-4822	2		CAPACITOR-FXD 1000PF +-5% 100VDC CER	28480	0160-4822
A11C85	0160-4822	2		CAPACITOR-FXD 1000PF +-5% 100VDC CER	28480	0160-4822
A11C86	0160-4835	7		CAPACITOR-FXD .1UF +-10% 50VDC CER	28480	0160-4835
A11C87	0180-3469	3		CAPACITOR-FXD 100UF +-20% 25VDC AL	28480	0180-3469
A11C88	0180-3469	3		CAPACITOR-FXD 100UF +-20% 25VDC AL	28480	0180-3469
A11C89	0180-3469	3		CAPACITOR-FXD 100UF +-20% 25VDC AL	28480	0180-3469
A11C90	0160-4800	6	3	CAPACITOR-FXD 120PF +-5% 100VDC CER	28480	0160-4800
A11C91	0160-4822	2		CAPACITOR-FXD 1000PF +-5% 100VDC CER	28480	0160-4822
A11C92	0160-3879	2		CAPACITOR-FXD 0.01U 20%	28480	0160-3879
A11C93	0160-4814	2		CAPACITOR-FXD 150PF +-5% 100VDC CER	28480	0160-4814
A11C94	0160-4800	6		CAPACITOR-FXD 120PF +-5% 100VDC CER	28480	0160-4800
A11C95	0160-4801	7		CAPACITOR-FXD 100PF +-5% 100VDC CER	28480	0160-4801

See introduction to this section for ordering information.
 * Indicates factory selected value.

Table 6-3. Replaceable Parts (continued)

Reference Designator	HP Part Number	C D	Qty.	Description	Mfr Code	Mfr Part Number
A11C96	0160-4814	2		CAPACITOR-FXD 150PF +-5% 100VDC CER	28480	0160-4814
A11C97	0160-4822	2		CAPACITOR-FXD 1000PF +-5% 100VDC CER	28480	0160-4822
A11C98	0160-4800	6		CAPACITOR-FXD 120PF +-5% 100VDC CER	28480	0160-4800
A11C99	0160-4814	2		CAPACITOR-FXD 150PF +-5% 100VDC CER	28480	0160-4814
A11C100	0160-4822	2		CAPACITOR-FXD 1000PF +-5% 100VDC CER	28480	0160-4822
A11C101	0160-4822	2		CAPACITOR-FXD 1000PF +-5% 100VDC CER	28480	0160-4822
A11C102	0160-4822	2		CAPACITOR-FXD 1000PF +-5% 100VDC CER	28480	0160-4822
A11C103	0160-4822	2		CAPACITOR-FXD 1000PF +-5% 100VDC CER	28480	0160-4822
A11C104	0160-4822	2		CAPACITOR-FXD 1000PF +-5% 100VDC CER	28480	0160-4822
A11C105	0180-3598	9		CAPACITOR-FXD 33UF +-20% 100VDC AL	28480	0180-3598
A11C106	0180-3598	9		CAPACITOR-FXD 33UF +-20% 100VDC AL	28480	0180-3598
A11C107	0160-3879	7		CAPACITOR-FXD .01UF +-20% 100VDC CER	28480	0160-3879
A11C108	0160-4822	2		CAPACITOR-FXD 1000PF +-5% 100VDC CER	28480	0160-4822
A11C109	0160-4822	2		CAPACITOR-FXD 1000PF +-5% 100VDC CER	28480	0160-4822
A11C110	0160-4822	2		CAPACITOR-FXD 1000PF +-5% 100VDC CER	28480	0160-4822
A11C111	0160-4822	2		CAPACITOR-FXD 1000PF +-5% 100VDC CER	28480	0160-4822
A11C112	0160-4822	2		CAPACITOR-FXD 1000PF +-5% 100VDC CER	28480	0160-4822
A11C113	0160-4491		1	CAPACITOR-FXD 8.2PF	28480	0160-4491
A11C114				NOT ASSIGNED		
A11C115	0160-3874			CAPACITOR-FXD 10PF 20V	28480	0160-3874
A11CR1	1902-3036	3	1	DIODE-ZNR 3.16V 5% DO-7 PD=.4W TC=-.064%	28480	1902-3036
A11CR2	1901-0040	1	8	DIODE-SWITCHING 30V 50MA 2NS DO-35	28480	1901-0040
A11CR3	1901-0040	1		DIODE-SWITCHING 30V 50MA 2NS DO-35	28480	1901-0040
A11CR4	1902-0951	5	2	DIODE-ZNR 5.1V 5% DO-35 PD=.4W TC=+.035%	28480	1902-0951
A11CR5	1902-0955	9	1	DIODE-ZNR 7.5V 5% DO-35 PD=.4W TC=+.062%	28480	1902-0955
A11CR6	1902-0959	3	2	DIODE-ZNR 11V 5% DO-35 PD=.4W TC=+.076%	28480	1902-0959
A11CR7	1902-0959	3		DIODE-ZNR 11V 5% DO-35 PD=.4W TC=+.076%	28480	1902-0959
A11CR8	1901-0050	3	1	DIODE-SWITCHING	28480	1901-0050
A11CR9	1901-0535	9	4	DIODE-SM SIG SCHOTTKY	28480	1901-0535
A11CR10	1901-0535	9		DIODE-SM SIG SCHOTTKY	28480	1901-0535
A11CR11	1901-0535	9		DIODE-SM SIG SCHOTTKY	28480	1901-0535
A11CR12	1901-0535	9		DIODE-SM SIG SCHOTTKY	28480	1901-0535
A11CR13	1901-0040	1		DIODE-SWITCHING 30V 50MA 2NS DO-35	28480	1901-0040
A11CR14	1901-0040	1		DIODE-SWITCHING 30V 50MA 2NS DO-35	28480	1901-0040
A11CR15	1901-0040	1		DIODE-SWITCHING 30V 50MA 2NS DO-35	28480	1901-0040
A11CR16	1901-0040	1		DIODE-SWITCHING 30V 50MA 2NS DO-35	28480	1901-0040
A11CR17	1902-0951	5		DIODE-ZNR 5.1V 5% DO-35 PD=.4W TC=+.035%	28480	1902-0951
A11CR18	0122-0109	0	2	DIODE-VVC	28480	0122-0109
A11CR19	0122-0109	0		DIODE-VVC	28480	0122-0109
A11CR20	1901-0040	1		DIODE-SWITCHING 30V 50MA 2NS DO-35	28480	1901-0040
A11CR21	1901-0040	1		DIODE-SWITCHING 30V 50MA 2NS DO-35	28480	1901-0040
A11CR22	1901-0518	8	2	DIODE-SM SIG SCHOTTKY	28480	1901-0518
A11CR23	1901-0518	8		DIODE-SM SIG SCHOTTKY	28480	1901-0518
A11J1	1200-0607	0	2	SOCKET-IC 16-CONT DIP DIP-SLDR	28480	1200-0607
A11J5	1200-0607	0		SOCKET-IC 16-CONT DIP DIP-SLDR	28480	1200-0607
A11L1	9100-2573	9	2	INDUCTOR RF-CH-MLD 1MH 10% .161DX.385LG	28480	9100-2573
A11L2	9100-2573	9		INDUCTOR RF-CH-MLD 1MH 10% .161DX.385LG	28480	9100-2573
A11L3	9140-0210	1	1	INDUCTOR RF-CH-MLD 100UH 5% .166DX.385LG	28480	9140-0210
A11L4	9140-0158	6	3	INDUCTOR RF-CH-MLD 1UH 10% .105DX.26LG	28480	9140-0158

See introduction to this section for ordering information.
 * Indicates factory selected value.

Table 6-3. Replaceable Parts (continued)

Reference Designator	HP Part Number	C D	Qty.	Description	Mfr Code	Mfr Part Number
A11L5	9140-1059	8	1	COIL 30M/40MH	28480	9140-1059
A11L6	9140-0158	6		INDUCTOR RF-CH-MLD 1UH 10% .105DX.26LG	28480	9140-0158
A11L7	9140-0158	6		INDUCTOR RF-CH-MLD 1UH 10% .105DX.26LG	28480	9140-0158
A11L8	9100-3559	3	1	INDUCTOR RF-CH-MLD 5.1UH 5% .166DX.385LG	28480	9100-3559
A11L9	9100-2249	6	2	INDUCTOR RF-CH-MLD 150NH 10% .105DX.26LG	28480	9100-2249
A11L10	9100-2249	6		INDUCTOR RF-CH-MLD 150NH 10% .105DX.26LG	28480	9100-2249
A11L11	9100-0368	6	2	INDUCTOR RF-CH-MLD 330NH 10% .105DX.26LG	28480	9100-0368
A11L12	9100-2251	0	1	INDUCTOR RF-CH-MLD 220NH 10% .105DX.26LG	28480	9100-2251
A11L13	9100-0368	6		INDUCTOR RF-CH-MLD 330NH 10% .105DX.26LG	28480	9100-0368
A11L14	9100-2259	8	1	INDUCTOR RF-CH-MLD 1.5UH 10% .105DX.26LG	28480	9100-2259
A11L15	9100-3139			INDUCTOR 75UH 15% .5DX .875LG	28480	9100-3139
A11L16	9100-3139	5		INDUCTOR 75UH 15% .5DX.875LG	28480	9100-3139
A11L17	9100-3139	5		INDUCTOR 75UH 15% .5DX.875LG	28480	9100-3139
A11Q1	1853-0591	4	2	TRANSISTOR PNP SI PD=1W FT=.05HZ	28480	1853-0591
A11Q2	1853-0591	4		TRANSISTOR PNP SI PD=1W FT=.05HZ	28480	1853-0591
A11Q3	1854-1076	4	3	TRANSISTOR NPN SI PD=1W FT=.05HZ	28480	1854-1076
A11Q4	1855-0570	3	4	TRANSISTOR J-FET D-MODE TO-92 SI	28480	1855-0570
A11Q5	1854-0296	8	6	TRANSISTOR NPN SI TO-92 PD=310MW	28480	1854-0296
A11Q6	1854-0296	8		TRANSISTOR NPN SI TO-92 PD=310MW	28480	1854-0296
A11Q7	1853-0089	5	5	TRANSISTOR PNP 2N4917 SI PD=200MW	07263	2N4917
A11Q8	1853-0089	5		TRANSISTOR PNP 2N4917 SI PD=200MW	07263	2N4917
A11Q9	1854-1076	4		TRANSISTOR NPN SI PD=1W FT=.05HZ	28480	1854-1076
A11Q10	1854-1076	4		TRANSISTOR NPN SI PD=1W FT=.05HZ	28480	1854-1076
A11Q11	1855-0570	3		TRANSISTOR J-FET D-MODE TO-92 SI	28480	1855-0570
A11Q12	1854-0296	8		TRANSISTOR NPN SI TO-92 PD=310MW	28480	1854-0296
A11Q13	1854-0296	8		TRANSISTOR NPN SI TO-92 PD=310MW	28480	1854-0296
A11Q14	1853-0036	2	6	TRANSISTOR PNP SI PD=310MW FT=250MHZ	28480	1853-0036
A11Q15	1854-0830	6	1	TRANSISTOR DUAL NPN PD=500MW	27014	LM394
A11Q16	1853-0036	2		TRANSISTOR PNP SI PD=310MW FT=250MHZ	28480	1853-0036
A11Q17	1854-0810	2	6	TRANSISTOR NPN SI PD=625MW FT=200MHZ	28480	1854-0810
A11Q18	1854-0810	2		TRANSISTOR NPN SI PD=625MW FT=200MHZ	28480	1854-0810
A11Q19	1854-0810	2		TRANSISTOR NPN SI PD=625MW FT=200MHZ	28480	1854-0810
A11Q20	1855-0308	5	1	TRANSISTOR JFET DUAL N-CHAN D-MODE SI	28480	1855-0308
A11Q21	1855-0082	2	2	TRANSISTOR J-FET P-CHAN D-MODE SI	28480	1855-0082
A11Q22	1855-0082	2		TRANSISTOR J-FET P-CHAN D-MODE SI	28480	1855-0082
A11Q23	1854-0810	2		TRANSISTOR NPN SI PD=625MW FT=200MHZ	28480	1854-0810
A11Q24	1853-0036	2		TRANSISTOR PNP SI PD=310MW FT=250MHZ	28480	1853-0036
A11Q25	1853-0036	2		TRANSISTOR PNP SI PD=310MW FT=250MHZ	28480	1853-0036
A11Q26	1854-0810	2		TRANSISTOR NPN SI PD=625MW FT=200MHZ	28480	1854-0810
A11Q27	1854-0215	1	3	TRANSISTOR NPN SI PD=350MW FT=300MHZ	04713	2N3904
A11Q28	1854-0215	1		TRANSISTOR NPN SI PD=350MW FT=300MHZ	04713	2N3904
A11Q29	1854-0810	2		TRANSISTOR NPN SI PD=625MW FT=200MHZ	28480	1854-0810
A11Q30	1853-0036	2		TRANSISTOR PNP SI PD=310MW FT=250MHZ	28480	1853-0036
A11Q31	1853-0036	2		TRANSISTOR PNP SI PD=310MW FT=250MHZ	28480	1853-0036
A11Q32	1855-0570	3		TRANSISTOR J-FET D-MODE TO-92 SI	28480	1855-0570
A11Q33	1855-0570	3		TRANSISTOR J-FET D-MODE TO-92 SI	28480	1855-0570
A11Q34	1854-0215	1		TRANSISTOR NPN SI PD=350MW FT=300MHZ	04713	2N3904
A11Q35	1853-0448	0	4	TRANSISTOR PNP SI TO-92 PD=625MW	04713	MPSH81
A11Q36	1853-0448	0		TRANSISTOR PNP SI TO-92 PD=625MW	04713	MPSH81

See introduction to this section for ordering information.
 * Indicates factory selected value.

Table 6-3. Replaceable Parts (continued)

Reference Designator	HP Part Number	C D	Qty.	Description	Mfr Code	Mfr Part Number
A11Q37	1854-0130	9	1	XSTR NPN 2SC1988	28480	1854-0130
A11Q38	1853-0448	0		TRANSISTOR PNP SI TO-92 PD=625MW	04713	MPSH81
A11Q39	1854-0345	8	4	TRANSISTOR NPN 2N5179 SI TO-72 PD=200MW	04713	2N5179
A11Q40	1853-0089	5		TRANSISTOR PNP 2N4917 SI PD=200MW	07263	2N4917
A11Q41	1853-0089	5		TRANSISTOR PNP 2N4917 SI PD=200MW	07263	2N4917
A11Q42	1853-0089	5		TRANSISTOR PNP 2N4917 SI PD=200MW	07263	2N4917
A11Q43	1853-0448	0		TRANSISTOR PNP SI TO-92 PD=625MW	04713	MPSH81
A11Q44	1854-0296	8		TRANSISTOR NPN SI TO-92 PD=310MW	28480	1854-0296
A11Q45	1854-0296	8		TRANSISTOR NPN SI TO-92 PD=310MW	28480	1854-0296
A11Q46	1854-0345	8		TRANSISTOR NPN 2N5179 SI TO-72 PD=200MW	04713	2N5179
A11Q47	1854-0345	8		TRANSISTOR NPN 2N5179 SI TO-72 PD=200MW	04713	2N5179
A11Q48	1854-0345	8		TRANSISTOR NPN 2N5179 SI TO-72 PD=200MW	04713	2N5179
A11R1	2100-3353	8	1	RESISTOR TRMR 20K 10% C SIDE-ADJ 1-TRN	28480	2100-3353
A11R2	0698-3444	1	5	RESISTOR 316 1% .125W F TC=0+-100	24546	C4-1/8-T0-316R-F
A11R3	0757-0278	9	7	RESISTOR 1.78K 1% .125W F TC=0+-100	24546	C4-1/8-T0-1781-F
A11R4	0757-0278	9		RESISTOR 1.78K 1% .125W F TC=0+-100	24546	C4-1/8-T0-1781-F
A11R5	0757-0278	9		RESISTOR 1.78K 1% .125W F TC=0+-100	24546	C4-1/8-T0-1781-F
A11R6	0698-0082	7	8	RESISTOR 464 1% .125W F TC=0+-100	24546	C4-1/8-T0-4640-F
A11R7	0757-0442	9	16	RESISTOR 10K 1% .125W F TC=0+-100	24546	C4-1/8-T0-1002-F
A11R8	2100-3273	1	1	RESISTOR TRMR 2K 10% C SIDE-ADJ 1-TRN	28480	2100-3273
A11R9	0757-0280	3	9	RESISTOR 1K 1% .125W F TC=0+-100	24546	C4-1/8-T0-1001-F
A11R10	0698-3441	8	13	RESISTOR 215 1% .125W F TC=0+-100	24546	C4-1/8-T0-215R-F
A11R11	0698-3441	8		RESISTOR 215 1% .125W F TC=0+-100	24546	C4-1/8-T0-215R-F
A11R12	0757-0421	4	5	RESISTOR 825 1% .125W F TC=0+-100	24546	C4-1/8-T0-825R-F
A11R13	0757-0416	7	3	RESISTOR 511 1% .125W F TC=0+-100	24546	C4-1/8-T0-511R-F
A11R14	0757-0416	7		RESISTOR 511 1% .125W F TC=0+-100	24546	C4-1/8-T0-511R-F
A11R15	0698-3441	8		RESISTOR 215 1% .125W F TC=0+-100	24546	C4-1/8-T0-215R-F
A11R16	0757-0200	7	3	RESISTOR 5.62K 1% .125W F TC=0+-100	24546	C4-1/8-T0-5621-F
A11R17	0757-0279	0	3	RESISTOR 3.16K 1% .125W F TC=0+-100	24546	C4-1/8-T0-3161-F
A11R18	0757-0288	1	2	RESISTOR 9.09K 1% .125W F TC=0+-100	19701	MF4C1/8-T0-9091-F
A11R19	0757-0274	5	5	RESISTOR 1.21K 1% .125W F TC=0+-100	24546	C4-1/8-T0-1211-F
A11R20	0698-3161	9	2	RESISTOR 38.3K 1% .125W F TC=0+-100	24546	C4-1/8-T0-3832-F
A11R21	0698-3161	9		RESISTOR 38.3K 1% .125W F TC=0+-100	24546	C4-1/8-T0-3832-F
A11R22	0698-3444	1		RESISTOR 316 1% .125W F TC=0+-100	24546	C4-1/8-T0-316R-F
A11R23	0757-0278	9		RESISTOR 1.78K 1% .125W F TC=0+-100	24546	C4-1/8-T0-1781-F
A11R24	0757-0465	6	1	RESISTOR 100K 1% .125W F TC=0+-100	24546	C4-1/8-T0-1003-F
A11R25	0757-0442	9		RESISTOR 10K 1% .125W F TC=0+-100	24546	C4-1/8-T0-1002-F
A11R26	0698-3499	6	1	RESISTOR 40.2K 1% .125W F TC=0+-100	24546	C4-1/8-T0-4022-F
A11R27	0757-0442	9		RESISTOR 10K 1% .125W F TC=0+-100	24546	C4-1/8-T0-1002-F
A11R28	0698-4037	0	25	RESISTOR 46.4 1% .125W F TC=0+-100	24546	C4-1/8-T0-46R4-F
A11R29	0757-0280	3		RESISTOR 1K 1% .125W F TC=0+-100	24546	C4-1/8-T0-1001-F
A11R30	0757-0280	3		RESISTOR 1K 1% .125W F TC=0+-100	24546	C4-1/8-T0-1001-F
A11R31	0698-3441	8		RESISTOR 215 1% .125W F TC=0+-100	24546	C4-1/8-T0-215R-F
A11R32	0698-3441	8		RESISTOR 215 1% .125W F TC=0+-100	24546	C4-1/8-T0-215R-F
A11R33	0757-0421	4		RESISTOR 825 1% .125W F TC=0+-100	24546	C4-1/8-T0-825R-F
A11R34	0698-3155	1	4	RESISTOR 4.64K 1% .125W F TC=0+-100	24546	C4-1/8-T0-4641-F
A11R35	0698-0084	9	10	RESISTOR 2.15K 1% .125W F TC=0+-100	24546	C4-1/8-T0-2151-F
A11R36	0698-0084	9		RESISTOR 2.15K 1% .125W F TC=0+-100	24546	C4-1/8-T0-2151-F
A11R37	0698-3156	2	1	RESISTOR 14.7K 1% .125W F TC=0+-100	24546	C4-1/8-T0-1472-F

See introduction to this section for ordering information.
 * Indicates factory selected value.

Table 6-3. Replaceable Parts (continued)

Reference Designator	HP Part Number	C D	Qty.	Description	Mfr Code	Mfr Part Number
A11R38	0757-0274	5		RESISTOR 1.21K 1% .125W F TC=0+-100	24546	C4-1/8-T0-1211-F
A11R39	0757-0279	0		RESISTOR 3.16K 1% .125W F TC=0+-100	24546	C4-1/8-T0-3161-F
A11R40	0698-0084	9		RESISTOR 2.15K 1% .125W F TC=0+-100	24546	C4-1/8-T0-2151-F
A11R41	0757-0442	9		RESISTOR 10K 1% .125W F TC=0+-100	24546	C4-1/8-T0-1002-F
A11R42	0757-0418	9	3	RESISTOR 619 1% .125W F TC=0+-100	24546	C4-1/8-T0-619R-F
A11R43	0698-4037	0		RESISTOR 46.4 1% .125W F TC=0+-100	24546	C4-1/8-T0-46R4-F
A11R44	0757-0441	8	1	RESISTOR 8.25K 1% .125W F TC=0+-100	24546	C4-1/8-T0-8251-F
A11R45	0698-4037	0		RESISTOR 46.4 1% .125W F TC=0+-100	24546	C4-1/8-T0-46R4-F
A11R46	0757-0280	3		RESISTOR 1K 1% .125W F TC=0+-100	24546	C4-1/8-T0-1002-F
A11R47	0698-0084	9		RESISTOR 2.15K 1% .125W F TC=0+-100	24546	C4-1/8-T0-2151-F
A11R48	0757-0444	1	4	RESISTOR 12.1K		
A11R49	0757-0442	9		RESISTOR 10K 1% .125W F TC=0+-100	24546	C4-1/8-T0-1002-F
A11R50	0698-0083	8	4	RESISTOR 1.96K 1% .125W F TC=0+-100	24546	C4-1/8-T0-1961-F
A11R51	0757-0444	1		RESISTOR 12.1K		
A11R52	0757-0444	1		RESISTOR 12.1K 1% .125W F TC=0+-100	24546	C4-1/8-T0-1212-F
A11R53	0698-4207	6	1	RESISTOR 44.2K 1% .125W F TC=0+-100	24546	C4-1/8-T0-4422-F
A11R54	0757-0280	3		RESISTOR 1K 1% .125W F TC=0+-100	24546	C4-1/8-T0-1001-F
A11R55	0698-4037	0		RESISTOR 46.4 1% .125W F TC=0+-100	24546	C4-1/8-T0-46R4-F
A11R56	0757-0442	9		RESISTOR 10K 1% .125W F TC=0+-100	24546	C4-1/8-T0-1002-F
A11R57	0698-4037	0		RESISTOR 46.4 1% .125W F TC=0+-100	24546	C4-1/8-T0-46R4-F
A11R58	2100-0552	3	1	RESISTOR-TRMR 50 10% C SIDE-ADJ 1-TRN	28480	2100-0552
A11R59	0698-0084	9		RESISTOR 2.15K 1% .125W F TC=0+-100	24546	C4-1/8-T0-2151-F
A11R60	0757-0442	9		RESISTOR 10K 1% .125W F TC=0+-100	24546	C4-1/8-T0-1002-F
A11R61	0757-0442	9		RESISTOR 10K 1% .125W F TC=0+-100	24546	C4-1/8-T0-1002-F
A11R62	0757-0420	3	1	RESISTOR 750 1% .125W F TC=0+-100	24546	C4-1/8-T0-751-F
A11R63	0757-0442	9		RESISTOR 10K 1% .125W F TC=0+-100	24546	C4-1/8-T0-1002-F
A11R64	0757-0442	9		RESISTOR 10K 1% .125W F TC=0+-100	24546	C4-1/8-T0-1002-F
A11R65	0698-3446	3	1	RESISTOR 383 1% .125W F TC=0+-100	24546	C4-1/8-T0-383R-F
A11R66	0698-3488	3		RESISTOR 442 1% .125W F TC=0+-100		
A11R67	0698-0082	7		RESISTOR 464 1% .125W F TC=0+-100	24546	C4-1/8-T0-4640-F
A11R68	0698-3155	1		RESISTOR 4.64K 1% .125W F TC=0+-100	24546	C4-1/8-T0-4641-F
A11R69	0698-4037	0		RESISTOR 46.4 1% .125W F TC=0+-100	24546	C4-1/8-T0-46R4-F
A11R70	0698-3430	5	3	RESISTOR 21.5 1% .125W F TC=0+-100	03888	PME55-1/8-T0-21R5-F
A11R71	0698-0082	7		RESISTOR 464 1% .125W F TC=0+-100	24546	C4-1/8-T0-4640-F
A11R72	0698-4037	0		RESISTOR 46.4 1% .125W F TC=0+-100	24546	C4-1/8-T0-46R4-F
A11R73	0757-0401	0	7	RESISTOR 100 1% .125W F TC=0+-100	24546	C4-1/8-T0-101-F
A11R74	0757-0401	0		RESISTOR 100 1% .125W F TC=0+-100	24546	C4-1/8-T0-101-F
A11R75	1810-0294	4	1	NETWORK-RESISTOR 16 PIN DIP; RES	28480	1810-0294
A11R76	2100-3154	7	1	RESISTOR-TRMR 1K 10% C SIDE-ADJ 17-TRN	02111	43P102
A11R77	2100-3054	6	1	RESISTOR-TRMR 50K 10% C SIDE-ADJ 17-TRN	02111	43P503
A11R78	0698-8961	7	1	RESISTOR 909K 1% .125W F TC=0+-100	28480	0698-8961
A11R79	0683-1065	7	1	RESISTOR 10M 5% .25W CC TC=-900/+1100	01121	CB1065
A11R80	0757-0401	0		RESISTOR 100 1% .125W F TC=0+-100	24546	C4-1/8-T0-101-F
A11R81	0757-0442	9		RESISTOR 10K 1% .125W F TC=0+-100	24546	C4-1/8-T0-1002-F
A11R82	0757-0200	7		RESISTOR 5.62K 1% .125W F TC=0+-100	24546	C4-1/8-T0-5621-F
A11R83	0698-0084	9		RESISTOR 2.15K 1% .125W F TC=0+-100	24546	C4-1/8-T0-2151-F
A11R84	0757-0401	0		RESISTOR 100 1% .125W F TC=0+-100	24546	C4-1/8-T0-101-F
A11R85	0757-0401	0		RESISTOR 100 1% .125W F TC=0+-100	24546	C4-1/8-T0-101-F
A11R86	0757-0346	2	3	RESISTOR 10 1% .125W F TC=0+-100	24546	C4-1/8-T0-10R0-F

See introduction to this section for ordering information.
* Indicates factory selected value.

Table 6-3. Replaceable Parts (continued)

Reference Designator	HP Part Number	C D	Qty.	Description	Mfr Code	Mfr Part Number
A11R87	0698-4037	0		RESISTOR 46.4 1% .125W F TC=0+-100	24546	C4-1/8-T0-46R4-F
A11R88	0698-0084	9		RESISTOR 2.15K 1% .125W F TC=0+-100	24546	C4-1/8-T0-2151-F
A11R89	0698-4037	0		RESISTOR 46.4 1% .125W F TC=0+-100	24546	C4-1/8-T0-46R4-F
A11R90	0698-3443	0	5	RESISTOR 287 1% .125W F TC=0+-100	24546	C4-1/8-T0-287R-F
A11R91	0757-0418	9		RESISTOR 619 1% .125W F TC=0+-100	24546	C4-1/8-T0-619R-F
A11R92	0757-0421	4		RESISTOR 825 1% .125W F TC=0+-100	24546	C4-1/8-T0-825R-F
A11R93	0757-0421	4		RESISTOR 825 1% .125W F TC=0+-100	24546	C4-1/8-T0-825R-F
A11R94	0698-0083	8		RESISTOR 1.96K 1% .125W F TC=0+-100	24546	C4-1/8-T0-1961-F
A11R95	0698-3152	8	1	RESISTOR 3.48K 1% .125W F TC=0+-100	24546	C4-1/8-T0-3481-F
A11R96	0757-0317	7	1	RESISTOR 1.33K 1% .125W F TC=0+-100	24546	C4-1/8-T0-1331-F
A11R97	0757-0442	9		RESISTOR 10K 1% .125W F TC=0+-100	24546	C4-1/8-T0-1002-F
A11R98	0757-0442	9		RESISTOR 10K 1% .125W F TC=0+-100	24546	C4-1/8-T0-1002-F
A11R99	0698-4037	0		RESISTOR 46.4 1% .125W F TC=0+-100	24546	C4-1/8-T0-46R4-F
A11R100	0757-0280	3		RESISTOR 1K 1% .125W F TC=0+-100	24546	C4-1/8-T0-1001-F
A11R101	0757-0395	1	5	RESISTOR 56.2 1% .125W F TC=0+-100	24546	C4-1/8-T0-56R2-F
A11R102	0757-0274	5		RESISTOR 1.21K 1% .125W F TC=0+-100	24546	C4-1/8-T0-1211-F
A11R103	0757-0274	5		RESISTOR 1.21K 1% .125W F TC=0+-100	24546	C4-1/8-T0-1211-F
A11R104	0698-4037	0		RESISTOR 46.4 1% .125W F TC=0+-100	24546	C4-1/8-T0-46R4-F
A11R105	0698-0082	7		RESISTOR 464 1% .125W F TC=0+-100	24546	C4-1/8-T0-4640-F
A11R106	0698-0082	7		RESISTOR 464 1% .125W F TC=0+-100	24546	C4-1/8-T0-4640-F
A11R107	0698-4037	0		RESISTOR 46.4 1% .125W F TC=0+-100	24546	C4-1/8-T0-46R4-F
A11R108	0698-4037	0		RESISTOR 46.4 1% .125W F TC=0+-100	24546	C4-1/8-T0-46R4-F
A11R109	0698-4037	0		RESISTOR 46.4 1% .125W F TC=0+-100	24546	C4-1/8-T0-46R4-F
A11R110	0698-3443	0		RESISTOR 287 1% .125W F TC=0+-100	24546	C4-1/8-T0-287R-F
A11R111	0757-0444	1		RESISTOR 12.1K 1% .125W F TC=0+-100	24546	C4-1/8-T0-1212-F
A11R112	0698-3155	1		RESISTOR 4.64K 1% .125W F TC=0+-100	24546	C4-1/8-T0-4641-F
A11R113	0757-0401	0		RESISTOR 100 1% .125W F TC=0+-100	24546	C4-1/8-T0-101-F
A11R114	0698-3441	8		RESISTOR 215 1% .125W F TC=0+-100	24546	C4-1/8-T0-215R-F
A11R115	0757-0279	0		RESISTOR 3.16K 1% .125W F TC=0+-100	24546	C4-1/8-T0-3161-F
A11R116	0698-3150	6	3	RESISTOR 2.37K 1% .125W F TC=0+-100	24546	C4-1/8-T0-2371-F
A11R117	0698-3150	6		RESISTOR 2.37K 1% .125W F TC=0+-100	24546	C4-1/8-T0-2371-F
A11R118	0698-0083	8		RESISTOR 1.96K 1% .125W F TC=0+-100	24546	C4-1/8-T0-1961-F
A11R119	0757-0442	9		RESISTOR 10K 1% .125W F TC=0+-100	24546	C4-1/8-T0-1002-F
A11R120	0698-3441	8		RESISTOR 215 1% .125W F TC=0+-100	24546	C4-1/8-T0-215R-F
A11R121	0698-3442	9	1	RESISTOR 237 1% .125W F TC=0+-100	24546	C4-1/8-T0-237R-F
A11R122	0698-0084	9		RESISTOR 2.15K 1% .125W F TC=0+-100	24546	C4-1/8-T0-2151-F
A11R123	0757-0280	3		RESISTOR 1K 1% .125W F TC=0+-100	24546	C4-1/8-T0-1001-F
A11R124	0757-0395	1		RESISTOR 56.2 1% .125W F TC=0+-100	24546	C4-1/8-T0-56R2-F
A11R125	0757-0419	0	4	RESISTOR 681 1% .125W F TC=0+-100	24546	C4-1/8-T0-681R-F
A11R126	0757-0419	0		RESISTOR 681 1% .125W F TC=0+-100	24546	C4-1/8-T0-681R-F
A11R127	0698-4037	0		RESISTOR 46.4 1% .125W F TC=0+-100	24546	C4-1/8-T0-46R4-F
A11R128	0698-0082	7		RESISTOR 464 1% .125W F TC=0+-100	24546	C4-1/8-T0-4640-F
A11R129	0757-0419	0		RESISTOR 681 1% .125W F TC=0+-100	24546	C4-1/8-T0-681R-F
A11R130	0698-0082	7		RESISTOR 464 1% .125W F TC=0+-100	24546	C4-1/8-T0-4640-F
A11R131	0698-4037	0		RESISTOR 46.4 1% .125W F TC=0+-100	24546	C4-1/8-T0-46R4-F
A11R132	0698-3441	8		RESISTOR 215 1% .125W F TC=0+-100	24546	C4-1/8-T0-215R-F
A11R133	0698-3430	5		RESISTOR 21.5 1% .125W F TC=0+-100	03888	PME55-1/8-T0-21R5-F
A11R134	0757-0278	9		RESISTOR 1.78K 1% .125W F TC=0+-100	24546	C4-1/8-T0-1781-F
A11R135	0757-0278	9		RESISTOR 1.78K 1% .125W F TC=0+-100	24546	C4-1/8-T0-1781-F

See introduction to this section for ordering information.
* Indicates factory selected value.

Table 6-3. Replaceable Parts (continued)

Reference Designator	HP Part Number	C D	Qty.	Description	Mfr Code	Mfr Part Number
A11R136	0757-0418	9		RESISTOR 619 1% .125W F TC=0+-100	24546	C4-1/8-T0-619R-F
A11R137	0757-0290	5	1	RESISTOR 6.19K 1% .125W F TC=0+-100	19701	MF4C1/8-T0-6191-F
A11R138	0757-0280	3		RESISTOR 1K 1% .125W F TC=0+-100	24546	C4-1/8-T0-1001-F
A11R139	0698-4037	0		RESISTOR 46.4 1% .125W F TC=0+-100	24546	C4-1/8-T0-46R4-F
A11R140	0757-0419	0		RESISTOR 681 1% .125W F TC=0+-100	24546	C4-1/8-T0-681R-F
A11R141	0698-3150	6		RESISTOR 2.37K 1% .125W F TC=0+-100	24546	C4-1/8-T0-2371-F
A11R142	0698-0083	8		RESISTOR 1.96K 1% .125W F TC=0+-100	24546	C4-1/8-T0-1961-F
A11R143	0757-0288	1		RESISTOR 9.09K 1% .125W F TC=0+-100	19701	MF4C1/8-T0-9091-F
A11R144	0757-1094	9	1	RESISTOR 1.47K 1% .125W F TC=0+-100	24546	C4-1/8-T0-1471-F
A11R145	0698-4037	0		RESISTOR 46.4 1% .125W F TC=0+-100	24546	C4-1/8-T0-46R4-F
A11R146	0757-0421	4		RESISTOR 825 1% .125W F TC=0+-100	24546	C4-1/8-T0-825R-F
A11R147	0698-0082	7		RESISTOR 464 1% .125W F TC=0+-100	24546	C4-1/8-T0-4640-F
A11R148	0757-0424	7	1	RESISTOR 1.1K 1% .125W F TC=0+-100	24546	C4-1/8-T0-1101-F
A11R149	0757-0398	4	1	RESISTOR 75 1% .125W F TC=0+-100	24546	C4-1/8-T0-75R0-F
A11R150	0698-4037	0		RESISTOR 46.4 1% .125W F TC=0+-100	24546	C4-1/8-T0-46R4-F
A11R151	0757-0442	9		RESISTOR 10K 1% .125W F TC=0+-100	24546	C4-1/8-T0-1002-F
A11R152	0698-3444	1		RESISTOR 316 1% .125W F TC=0+-100	24546	C4-1/8-T0-316R-F
A11R153	0698-4037	0		RESISTOR 46.4 1% .125W F TC=0+-100	24546	C4-1/8-T0-46R4-F
A11R154	0757-0439	4	1	RESISTOR 6.81K 1% .125W F TC=0+-100	24546	C4-1/8-T0-6811-F
A11R155	0698-3155	1		RESISTOR 4.64K 1% .125W F TC=0+-100	24546	C4-1/8-T0-4641-F
A11R156	0757-0417	8		RESISTOR 562 1% .125W F TC=0+-100	24546	C4-1/8-T0-562R-F
A11R157	0698-4037	0		RESISTOR 46.4 1% .125W F TC=0+-100	24546	C4-1/8-T0-46R4-F
A11R158	0698-4037	0		RESISTOR 46.4 1% .125W F TC=0+-100	24546	C4-1/8-T0-46R4-F
A11R159	0757-0280	3		RESISTOR 1K 1% .125W F TC=0+-100	24546	C4-1/8-T0-1001-F
A11R160	0698-4037	0		RESISTOR 46.4 1% .125W F TC=0+-100	24546	C4-1/8-T0-46R4-F
A11R161	0698-3430	5		RESISTOR 21.5 1% .125W F TC=0+-100	03888	PME55-1/8-T0-21R5-F
A11R162	0757-0403	2	1	RESISTOR 121 1% .125W F TC=0+-100	24546	C4-1/8-T0-121R-F
A11R163	0698-3441	8		RESISTOR 215 1% .125W F TC=0+-100	24546	C4-1/8-T0-215R-F
A11R164	0698-3439	4	2	RESISTOR 178 1% .125W F TC=0+-100	24546	C4-1/8-T0-178R-F
A11R165	0757-0180	2	1	RESISTOR 31.6 1% .125W F TC=0+-100	28480	0757-0180
A11R166	0698-3439	4		RESISTOR 178 1% .125W F TC=0+-100	24546	C4-1/8-T0-178R-F
A11R167	0698-3443	0		RESISTOR 287 1% .125W F TC=0+-100	24546	C4-1/8-T0-287R-F
A11R168	0757-0294	9	1	RESISTOR 17.8 1% .125W F TC=0+-100	19701	MF4C1/8-T0-17R8-F
A11R169	0698-3443	0		RESISTOR 287 1% .125W F TC=0+-100	24546	C4-1/8-T0-287R-F
A11R170	0757-0416	7		RESISTOR 511 1% .125W F TC=0+-100	24546	C4-1/8-T0-511R-F
A11R171	0757-0417	8		RESISTOR 562 1% .125W F TC=0+-100	24546	C4-1/8-T0-562R-F
A11R172	0757-0417	8		RESISTOR 562 1% .125W F TC=0+-100	24546	C4-1/8-T0-562R-F
A11R173	0757-0417	8		RESISTOR 562 1% .125W F TC=0+-100	24546	C4-1/8-T0-562R-F
A11R174	0698-3441	8		RESISTOR 215 1% .125W F TC=0+-100	24546	C4-1/8-T0-215R-F
A11R175	0698-3441	8		RESISTOR 215 1% .125W F TC=0+-100	24546	C4-1/8-T0-215R-F
A11R176	0757-0428	1	2	RESISTOR 1.62K 1% .125W F TC=0+-100	24546	C4-1/8-T0-1621-F
A11R177	0757-0442	9		RESISTOR 10K 1% .125W F TC=0+-100	24546	C4-1/8-T0-1002-F
A11R178	0757-0428	1		RESISTOR 1.62K 1% .125W F TC=0+-100	24546	C4-1/8-T0-1621-F
A11R179	0698-3153	9	2	RESISTOR 3.83K 1% .125W F TC=0+-100	24546	C4-1/8-T0-3831-F
A11R180	1810-0205	7	1	NETWORK-RES 8-SIP4.7K OHM X 7	01121	208A472
A11R181	0757-0278	9		RESISTOR 1.78K 1% .125W F TC=0+-100	24546	C4-1/8-T0-1781-F
A11R182	0757-0281	4	1	RESISTOR 2.74K 1% .125W F TC=0+-100	24546	C4-1/8-T0-2741-F
A11R183	0698-4037	0		RESISTOR 46.4 1% .125W F TC=0+-100	24546	C4-1/8-T0-46R4-F
A11R184	0698-3443	0		RESISTOR 287 1% .125W F TC=0+-100	24546	C4-1/8-T0-287R-F

See introduction to this section for ordering information.
 * Indicates factory selected value.

Table 6-3. Replaceable Parts (continued)

Reference Designator	HP Part Number	C D	Qty.	Description	Mfr Code	Mfr Part Number
A11R185	0698-3444	1		RESISTOR 316 1% .125W F TC=0+-100	24546	C4-1/8-T0-316R-F
A11R186	0698-3444	1		RESISTOR 316 1% .125W F TC=0+-100	24546	C4-1/8-T0-316R-F
A11R187	0698-4037	0		RESISTOR 46.4 1% .125W F TC=0+-100	24546	C4-1/8-T0-46R4-F
A11R188	0757-0401	0		RESISTOR 100 1% .125W F TC=0+-100	24546	C4-1/8-T0-101-F
A11R189	0757-0274	5		RESISTOR 1.21K 1% .125W F TC=0+-100	24546	C4-1/8-T0-1211-F
A11R190	0757-0417	8		RESISTOR 562 1% .125W F TC=0+-100	24546	C4-1/8-T0-562R-F
A11R191	0757-0395	1		RESISTOR 56.2 1% .125W F TC=0+-100	24546	C4-1/8-T0-56R2-F
A11R192	0757-0395	1		RESISTOR 56.2 1% .125W F TC=0+-100	24546	C4-1/8-T0-56R2-F
A11R193	0698-3441	8		RESISTOR 215 1% .125W F TC=0+-100	24546	C4-1/8-T0-215R-F
A11R194	0698-3441	8		RESISTOR 215 1% .125W F TC=0+-100	24546	C4-1/8-T0-215R-F
A11R195	0698-3153	9		RESISTOR 3.83K 1% .125W F TC=0+-100	24546	C4-1/8-T0-3831-F
A11R196	0698-0084	9		RESISTOR 2.15K 1% .125W F TC=0+-100	24546	C4-1/8-T0-2151-F
A11R197	0698-0084	9		RESISTOR 2.15K 1% .125W F TC=0+-100	24546	C4-1/8-T0-2151-F
A11R198	0757-0395	1		RESISTOR 56.2 1% .125W F TC=0+-100	24546	C4-1/8-T0-56R2-F
A11R199	0757-0346	2		RESISTOR 10 1% .125W F TC=0+-100	24546	C4-1/8-T0-10R0-F
A11R200	0698-3438	3	1	RESISTOR 147 1% .125W F TC=0+-100	24546	C4-1/8-T0-147R-F
A11R201	0757-0346	2		RESISTOR 10 1% .125W F TC=0+-100	24546	C4-1/8-T0-10R0-F
A11R202	0698-7205			RESISTOR 51.1 0.05W		
A11U1	1826-0021	8	1	IC OP AMP GP TO-99 PKG	27014	LM310H
A11U2	1820-2691	0	2	IC FF TTL F D-TYPE POS-EDGE-TRIG	07263	74F74PC
A11U3	1820-2694	3	8	IC FF TTL F J-K NEG-EDGE-TRIG	07263	74F112PC
A11U4	1826-0783	9	1	IC OP AMP LOW-NOISE 8-DIP-C PKG	52063	XR5534ACN
A11U5	1820-2694	3		IC FF TTL F J-K NEG-EDGE-TRIG	07263	74F112PC
A11U6	1820-1144	6	1	IC GATE TTL LS NOR QUAD 2-INP	01295	SN74LS02N
A11U7	1820-2694	3		IC FF TTL F J-K NEG-EDGE-TRIG	07263	74F112PC
A11U8	1820-2694	3		IC FF TTL F J-K NEG-EDGE-TRIG	07263	74F112PC
A11U9	1820-2691	0		IC FF TTL F D-TYPE POS-EDGE-TRIG	07263	74F74PC
A11U10	1820-2694	3		IC FF TTL F J-K NEG-EDGE-TRIG	07263	74F112PC
A11U11	1820-1196	8	3	IC FF TTL LS D-TYPE POS-EDGE-TRIG COM	01295	SN74LS174N
A11U12	1820-2004	9	1	IC MISC NMOS	28480	1820-2004
A11U13	1820-2506	6	2	IC INV TTL F HEX	07263	74F04PC
A11U14	1820-2684	1	3	IC GATE TTL F NAND QUAD 2-INP	07263	74F00PC
A11U15	1820-2684	1		IC GATE TTL F NAND QUAD 2-INP	07263	74F00PC
A11U16	1820-1196	8		IC FF TTL LS D-TYPE POS-EDGE-TRIG COM	01295	SN74LS174N
A11U17	1820-1196	8		IC FF TTL LS D-TYPE POS-EDGE-TRIG COM	01295	SN74LS174N
A11U18	1820-2685	2	1	IC GATE TTL F NOR QUAD 2-INP	07263	74F02PC
A11U19	1820-2694	3		IC FF TTL F J-K NEG-EDGE-TRIG	07263	74F112PC
A11U20	1821-0001	4	1	TRANSISTOR ARRAY 14-PIN PLSTC DIP	3L585	CA3046
A11U21	1820-1112	8	1	IC FF TTL LS D-TYPE POS-EDGE-TRIG	01295	SN74LS74AN
A11U22	1820-1279	8	2	IC CNTR TTL LS DECD UP/DOWN SYNCHRO	01295	SN74LS190N
A11U23	1820-1279	8		IC CNTR TTL LS DECD UP/DOWN SYNCHRO	01295	SN74LS190N
A11U24	1820-2684	1		IC GATE TTL F NAND QUAD 2-INP	07263	74F00PC
A11U25	1820-2694	3		IC FF TTL F J-K NEG-EDGE-TRIG	07263	74F112PC
A11U26	1820-0817	8	1	IC FF ECL D-M/S DUAL	04713	MC10131P
A11U27	1820-2694	3		IC FF TTL F J-K NEG-EDGE-TRIG	07263	74F112PC
A11U28	1820-2506	6		IC INV TTL F HEX	07263	74F04PC
A11U29	1826-1310	0	2	IC RF/IF AMPL WB 4-DIP-P PKG	28480	1826-1310
A11U30	1826-1310	0		IC RF/IF AMPL WB 4-DIP-P PKG	28480	1826-1310
A11U31	1826-1311	1	1	IC RF/IF AMPL WB 4-DIP-P PKG	28480	1826-1311

See introduction to this section for ordering information.
 * Indicates factory selected value.

Table 6-3. Replaceable Parts (continued)

Reference Designator	HP Part Number	C D	Qty.	Description	Mfr Code	Mfr Part Number
A11U32	1820-0794	0	1	IC FF ECL D-M/S	04713	MC1670L
A11U33	1820-2849	0	1	IC FF ECL/10KH D-M/S DUAL	28480	1820-2849
A11U34	1826-0139	9	1	IC OP AMP GP DUAL 8-DIP-P PKG	3L585	CA1458G
A11U35	1820-1246	9	1	IC GATE TTL LS AND QUAD 2-INP	01295	SN74LS09N
A11XL	1252-0720	7	2	CONN DIN 96PF	28480	1252-0720
A11XR	1252-0720	7		CONN DIN 96PF	28480	1252-0720
	4040-0749	4	2	EXTR-PC BD BRN POLYC .062-BD-THKNS	28480	4040-0749

See introduction to this section for ordering information.
 * Indicates factory selected value.

Table 6-3. Replaceable Parts (continued)

Reference Designator	HP Part Number	C D	Qty.	Description	Mfr Code	Mfr Part Number
A12	04194-66512	4	1	KEYBOARD CONTROL BOARD ASSEMBLY	28480	04194-66512
A12C1	0180-0197	8	1	CAPACITOR-FXD 2.2UF+-10% 20VDC TA	56289	150D225X9020A2
A12C2	0180-3217	9	1	CAPACITOR-FXD 470UF	28480	0180-3217
A12C3	0160-4835	7	9	CAPACITOR-FXD .1UF +-10% 50VDC CER	28480	0160-4835
A12C4	0160-4835	7		CAPACITOR-FXD .1UF +-10% 50VDC CER	28480	0160-4835
A12C5	0160-4835	7		CAPACITOR-FXD .1UF +-10% 50VDC CER	28480	0160-4835
A12C6	0160-4835	7		CAPACITOR-FXD .1UF +-10% 50VDC CER	28480	0160-4835
A12C7	0160-4835	7		CAPACITOR-FXD .1UF +-10% 50VDC CER	28480	0160-4835
A12C8	0160-4835	7		CAPACITOR-FXD .1UF +-10% 50VDC CER	28480	0160-4835
A12C9	0160-4835	7		CAPACITOR-FXD .1UF +-10% 50VDC CER	28480	0160-4835
A12C10	0160-4835	7		CAPACITOR-FXD .1UF +-10% 50VDC CER	28480	0160-4835
A12C11	0160-4835	7		CAPACITOR-FXD .1UF +-10% 50VDC CER	28480	0160-4835
A12C12	0180-1085	5	3	CAPACITOR-FXD 4.7UF 16VDC TA	28480	0180-1085
A12C13	0180-1085	5		CAPACITOR-FXD 4.7UF 16VDC TA	28480	0180-1085
A12C14	0180-1085	5		CAPACITOR-FXD 4.7UF 16VDC TA	28480	0180-1085
A12J1	1251-3025	9	1	CONNECTOR 34-PIN M RECTANGULAR	28480	1251-3025
A12J2	0360-1705	8	1	CABLE TRANSITION 40-TERM INSUL DSPL TYPE	28480	0360-1705
A12L1	9170-0847	3	4	CORE SHIELDING BEAD PARYLENE COATED	02114	56-590-65/3B
A12Q1	1854-0810	2	2	TRANSISTOR NPN SI PD=625MW FT=200MHZ	28480	1854-0810
A12Q2	1854-0810	2		TRANSISTOR NPN SI PD=625MW FT=200MHZ	28480	1854-0810
A12Q3	1853-0459	3	2	TRANSISTOR PNP SI PD=625MW FT=200MHZ	28480	1853-0459
A12Q4	1853-0459	3		TRANSISTOR PNP SI PD=625MW FT=200MHZ	28480	1853-0459
A12R1	0698-3452	1	1	RESISTOR 147K 1% .125W F TC=0+-100	24546	C4-1/8-T0-1473-F
A12R2	0698-3446	3	1	RESISTOR 383 1% .125W F TC=0+-100	24546	C4-1/8-T0-383R-F
A12R3	0757-0465	6	1	RESISTOR 100K 1% .125W F TC=0+-100	24546	C4-1/8-T0-1003-F
A12R4	0757-0442	9	2	RESISTOR 10K 1% .125W F TC=0+-100	24546	C4-1/8-T0-1002-F
A12R5	0698-3153	9	1	RESISTOR 3.83K 1% .125W F TC=0+-100	24546	C4-1/8-T0-3831-F
A12R6	0698-0084	9	1	RESISTOR 2.15K 1% .125W F TC=0+-100	24546	C4-1/8-T0-2151-F
A12R7	0757-0442	9		RESISTOR 10K 1% .125W F TC=0+-100	24546	C4-1/8-T0-1002-F
A12R8	1810-0269	3	1	NETWORK-RES 9-SIP10.0K OHM X 8	28480	1810-0269
A12R9	1810-0279	5	1	NETWORK-RES 10-SIP4.7K OHM X 9	01121	210A472
A12R10	0757-0419	0	3	RESISTOR 681 1% .125W F TC=0+-100	24546	C4-1/8-T0-681R-F
A12R11	0757-0419	0		RESISTOR 681 1% .125W F TC=0+-100	24546	C4-1/8-T0-681R-F
A12R12	0757-0419	0		RESISTOR 681 1% .125W F TC=0+-100	24546	C4-1/8-T0-681R-F
A12R13	0757-1094	9	2	RESISTOR 1.47K 1% .125W F TC=0+-100	24546	C4-1/8-T0-1471-F
A12R14	0698-3438	3	1	RESISTOR 147 1% .125W F TC=0+-100	24546	C4-1/8-T0-147R-F
A12R15	0757-1094	9		RESISTOR 1.47K 1% .125W F TC=0+-100	24546	C4-1/8-T0-1471-F
A12R16	0698-3438	3		RESISTOR 147 1% .125W F TC=0+-100	24546	C4-1/8-T0-147R-F
A12R17	1810-0325	2	1	NETWORK-RES 16-DIP150.0 OHM X 8	01121	316B151
A12R18	0698-3430	5	2	RESISTOR 21.5 1% .125W F TC=0+-100	03888	PME55-1/8-T0-21R5-F
A12R19	0698-3160	8	2	RESISTOR 31.6K 1% .125W F TC=0+-100	24546	C4-1/8-T0-3162-F
A12R20	0698-3160	8		RESISTOR 31.6K 1% .125W F TC=0+-100	24546	C4-1/8-T0-3162-F
A12R21	0698-3430	5		RESISTOR 21.5 1% .125W F TC=0+-100	03888	PME55-1/8-T0-21R5-F
A12SP1	9164-0262	3	1	BUZZER	28480	9164-0262
A12U1	1820-1423	4	1	IC MV TTL LS MONOSTBL RETRIG DUAL	01295	SN74LS123N
A12U2	1820-2635	2	2	IC GATE TTL ALS AND QUAD 2-INP	01295	SN74ALS08N
A12U3	1820-1445	0	1	IC LCH TTL LS 4-BIT	01295	SN74LS375N
A12U4	1820-1478	9	1	IC CNTR TTL LS BIN ASYNCHRO	01295	SN74LS93N

See introduction to this section for ordering information.
 * Indicates factory selected value.

Table 6-3. Replaceable Parts (continued)

Reference Designator	HP Part Number	C D	Qty.	Description	Mfr Code	Mfr Part Number
A12U5	1820-2635	2		IC GATE TTL ALS AND QUAD 2-INP	01295	SN74ALS08N
A12U6	1820-2488	3	2	IC FF TTL ALS D-TYPE POS-EDGE-TRIG	01295	SN74ALS74N
A12U7	1820-2656	7	1	IC GATE TTL ALS NAND QUAD 2-INP	01295	SN74ALS00N
A12U8	1820-3100	8	2	IC DCDR TTL ALS BIN 3-TO-8-LINE 3-INP	28480	1820-3100
A12U9	04194-80008	3	1	PAL 10H8	28480	04194-80008
A12U10	1820-3121	3	1	IC TRANSCEIVER TTL ALS BUS OCTL	28480	1820-3121
A12U11	1820-2150	6	1	IC MICPROC-ACCESS NMOS	34649	08279-5
A12U12	1820-2488	3		IC FF TTL ALS D-TYPE POS-EDGE-TRIG	01295	SN74ALS74N
A12U13	04194-80006	1	1	PAL16R4L	28480	04194-80006
A12U14	04194-80007	2	1	PAL 16R6L	28480	04194-80007
A12U15	04194-80009	4	1	PAL 10H8	28480	04194-80009
A12U16	1820-4350	2	1	74ALS241AN		74ALS241AN
A12U17	1820-3100	8		IC DCDR TTL ALS BIN 3-TO-8-LINE 3-INP	28480	1820-3100
A12U18	1820-1416	5	1	IC SCHMITT-TRIG TTL LS INV HEX 1-INP	01295	SN74LS14N
	8150-3490	5	1	WIRE	28480	8150-3490
	04194-61633	0	1	FLAT CABLE ASSY	28480	04194-61633

See introduction to this section for ordering information.
 * Indicates factory selected value.

Table 6-3. Replaceable Parts (continued)

Reference Designator	HP Part Number	C D	Qty.	Description	Mfr Code	Mfr Part Number
A13	04194-66513	5	1	CONTROL UNIT KEYBOARD ASSEMBLY	28480	04194-66513
A13DS1	1990-0670	0	6	LED-LAMP LUM-INT=1MCD IF=20MA-MAX BVR=5V	28480	1990-0670
A13DS2	1990-0670	0		LED-LAMP LUM-INT=1MCD IF=20MA-MAX BVR=5V	28480	1990-0670
A13DS3	1990-0670	0		LED-LAMP LUM-INT=1MCD IF=20MA-MAX BVR=5V	28480	1990-0670
A13DS4	1990-0670	0		LED-LAMP LUM-INT=1MCD IF=20MA-MAX BVR=5V	28480	1990-0670
A13DS5	1990-0678	8	1	LED-LAMP LUM-INT=800UCD IF=60MA-MAX	28480	1990-0678
A13DS6	1990-0670	0		LED-LAMP LUM-INT=1MCD IF=20MA-MAX BVR=5V	28480	1990-0670
A13DS7	1990-0487	7	9	LED-LAMP LUM-INT=1MCD IF=20MA-MAX BVR=5V	28480	5082-4584
A13DS8	1990-0487	7		LED-LAMP LUM-INT=1MCD IF=20MA-MAX BVR=5V	28480	5082-4584
A13DS9	1990-0487	7		LED-LAMP LUM-INT=1MCD IF=20MA-MAX BVR=5V	28480	5082-4584
A13DS10	1990-0487	7		LED-LAMP LUM-INT=1MCD IF=20MA-MAX BVR=5V	28480	5082-4584
A13DS11	1990-0487	7		LED-LAMP LUM-INT=1MCD IF=20MA-MAX BVR=5V	28480	5082-4584
A13DS12	1990-0487	7		LED-LAMP LUM-INT=1MCD IF=20MA-MAX BVR=5V	28480	5082-4584
A13DS13	1990-0487	7		LED-LAMP LUM-INT=1MCD IF=20MA-MAX BVR=5V	28480	5082-4584
A13DS14	1990-0670	0		LED-LAMP LUM-INT=1MCD IF=20MA-MAX BVR=5V	28480	1990-0670
A13DS15	1990-0487	7		LED-LAMP LUM-INT=1MCD IF=20MA-MAX BVR=5V	28480	5082-4584
A13DS16	1990-0487	7		LED-LAMP LUM-INT=1MCD IF=20MA-MAX BVR=5V	28480	5082-4584
A13J1	1251-3004	4	1	CONNECTOR 40-PIN M RECTANGULAR	28480	1251-3004
A13RPG	0960-0683	1	1	ROTARY PULSE GENERATOR INPUT POWER: 5VDC	28480	0960-0683
A13S1-						
A13S69	5060-9436	7	69	PUSHBUTTON SWITCH P.C. MOUNT	28480	5060-9436
	5041-0276	5	4	KEY CAP PRL GRAY	28480	5041-0276
	5041-0277	6	8	HAF-PRL	28480	5041-0277
	5041-0285	6	5	QTR-L-PRL	28480	5041-0285
	5041-0342	6	20	KEY CAP	28480	5041-0342
	5041-0343	7	6	HALF KEY CAP	28480	5041-0343
	5041-0351	7	1	KEY CAP	28480	5041-0351
	5041-0375	5	6	QTR-SMK	28480	5041-0375
	5041-0450	7	1	KEY CAP	28480	5041-0450
	5041-0507	5	1	KEY CAP	28480	5041-0507
	5041-0726	0	1	KEY Q-LCL	28480	5041-0726
	5041-0855	6	2	HAF-EBY-PRL	28480	5041-0855
	5041-0922	8	3	QTR-EBY-PRL	28480	5041-0922
	5041-1755	7	1	KEY QUARTER (.)	28480	5041-1755
	5041-1756	8	1	KEY QUARTER (0)	28480	5041-1756
	5041-1757	9	1	KEY QUARTER (1)	28480	5041-1757
	5041-1758	0	1	KEY QUARTER (2)	28480	5041-1758
	5041-1759	1	1	KEY QUARTER (3)	28480	5041-1759
	5041-1760	4	1	KEY QUARTER (4)	28480	5041-1760
	5041-1761	5	1	KEY QUARTER (5)	28480	5041-1761
	5041-1762	6	2	KEY QUARTER (6)	28480	5041-1762
	5041-1763	7	1	KEY QUARTER (7)	28480	5041-1763
	5041-1764	8	1	KEY QUARTER (8)	28480	5041-1764
	04191-40002	0	1	INSULATOR	28480	04191-40002

See introduction to this section for ordering information.
 * Indicates factory selected value.

Table 6-3. Replaceable Parts (continued)

Reference Designator	HP Part Number	C D	Qty.	Description	Mfr Code	Mfr Part Number
A14	04194-66514	6	1	POWER SUPPLY MOTHERBOARD ASSEMBLY	28480	04194-66514
A14J1	1251-3837	1	1	CONNECTOR 4-PIN M UTILITY	28480	1251-3837
A14J2	1251-7981	4	1	CONN-POST TYPE .156-PIN-SPCG 2-CONT	28480	1251-7981
A14J3	1251-5339	2	1	CONNECTOR 9-PIN M UTILITY	28480	1251-5339
A14XA1	1252-0809	3	2	DIN CONN 96PIN F	28480	1252-0809
A14XA2	1252-0809	3		DIN CONN 96PIN F	28480	1252-0809
A14XA3	1252-0811	7	1	DIN CONN 96PIN F	28480	1252-0811

See introduction to this section for ordering information.
 * Indicates factory selected value.

Table 6-3. Replaceable Parts (continued)

Reference Designator	HP Part Number	C D	Qty.	Description	Mfr Code	Mfr Part Number
A15	04194-66515	7	1	MOTHERBOARD ASSEMBLY	28480	04194-66515
A15J1	1251-5066	2	1	CONNECTOR 2-PIN M METRIC POST TYPE	28480	1251-5066
A15J2	1251-3024	8	2	CONNECTOR 26-PIN M RECTANGULAR	28480	1251-3024
A15J3	1251-3024	8		CONNECTOR 26-PIN M RECTANGULAR	28480	1251-3024
A15J4	1251-3090	8	1	CONNECTOR 50-PIN M RECTANGULAR	28480	1251-3090
A15J5	1250-0257	1	6	CONNECTOR-RF SMB M PC 50-OHM	28480	1250-0257
A15J6	1250-0257	1		CONNECTOR-RF SMB M PC 50-OHM	28480	1250-0257
A15J7	1250-0257	1		CONNECTOR-RF SMB M PC 50-OHM	28480	1250-0257
A15J8	1250-0257	1		CONNECTOR-RF SMB M PC 50-OHM	28480	1250-0257
A15J9	1250-0257	1		CONNECTOR-RF SMB M PC 50-OHM	28480	1250-0257
A15J10	1250-0257	1		CONNECTOR-RF SMB M PC 50-OHM	28480	1250-0257
A15W1	0360-1901	6	1	CABLE TRANSITION 34-TERM GL-FLD-POLYE	28480	0360-1901
A15W2	0362-0390	9	1	CABLE TRANSITION 26-TERM INSUL DSPL TYPE	28480	0362-0390
A15XA6L	1252-0721	8	12	CONN DIN 96PIN F	28480	1252-0721
A15XA6R	1252-0721	8		CONN DIN 96PIN F	28480	1252-0721
A15XA7L	1252-0721	8		CONN DIN 96PIN F	28480	1252-0721
A15XA7R	1252-0721	8		CONN DIN 96PIN F	28480	1252-0721
A15XA8L	1252-0721	8		CONN DIN 96PIN F	28480	1252-0721
A15XA8R	1252-0721	8		CONN DIN 96PIN F	28480	1252-0721
A15XA9L	1252-0721	8		CONN DIN 96PIN F	28480	1252-0721
A15XA9R	1252-0721	8		CONN DIN 96PIN F	28480	1252-0721
A15XA10L	1252-0721	8		CONN DIN 96PIN F	28480	1252-0721
A15XA10R	1252-0721	8		CONN DIN 96PIN F	28480	1252-0721
A15XA11L	1252-0721	8		CONN DIN 96PIN F	28480	1252-0721
A15XA11R	1252-0721	8		CONN DIN 96PIN F	28480	1252-0721

See introduction to this section for ordering information.
 * Indicates factory selected value.

Table 6-3. Replaceable Parts (continued)

Reference Designator	HP Part Number	C D	Qty.	Description	Mfr Code	Mfr Part Number
A17	04194-66517	9	1	CRT SOCKET BOARD ASSEMBLY	28480	04194-66517
A17C1	0160-3202	0	2	CAPACITOR-FXD 1800PF +-20% 3KVDC CER	28480	0160-3202
A17C2	0160-3202	0		CAPACITOR-FXD 1800PF +-20% 3KVDC CER	28480	0160-3202
A17C3	0160-2902	5	1	CAPACITOR-FXD .01UF +-20% 1KVDC CER	28480	0160-2902
A17C4	0160-3455	5	1	CAPACITOR-FXD 470PF +-10% 1KVDC CER	28480	0160-3455
A17DS1	2140-0546	9	3	LAMP-GLOW 240V	28480	2140-0546
A17DS2	2140-0546	9		LAMP-GLOW 240V	28480	2140-0546
A17DS3	2140-0546	9		LAMP-GLOW 240V	28480	2140-0546
A17DS4	2140-0013	5	1	LAMP-GLOW 5AB-A 70/57VDC 300UA T-2-BULB	08806	5AB-A(NE-23A)
A17E1	0837-0338	1	1	SPARK GAP 2KV	28480	0837-0338
A17J1	04194-81201	0	1	SOCKET CRT	28480	04194-81201
A17J2	1251-5066	2	1	CONNECTOR 2-PIN M METRIC POST TYPE	28480	1251-5066
A17L1	9140-0114	4	3	INDUCTOR RF-CH-MLD 10UH 10% .166DX.385LG	28480	9140-0114
A17L2	9140-0114	4		INDUCTOR RF-CH-MLD 10UH 10% .166DX.385LG	28480	9140-0114
A17L3	9140-0114	4		INDUCTOR RF-CH-MLD 10UH 10% .166DX.385LG	28480	9140-0114
A17L4	9140-1078	3	1	COIL 22UH	28480	9140-1078
A17R1	2100-4117	4	1	RES VR 7.5M OHM	28480	2100-4117
A17R2	0683-2255	9	2	RESISTOR 2.2M 5% .25W FC TC=-900/+1100	01121	CB2255
A17R3	0683-2255	9		RESISTOR 2.2M 5% .25W FC TC=-900/+1100	01121	CB2255
A17R4	0687-1041	7	1	RESISTOR 100K 10% .5W CC TC=0+882	01121	EB1041
A17R5	0686-3315	0	3	RESISTOR 330 5% .5W CC TC=0+529	01121	EB3315
A17R6	0686-3315	0		RESISTOR 330 5% .5W CC TC=0+529	01121	EB3315
A17R7	0686-3315	0		RESISTOR 330 5% .5W CC TC=0+529	01121	EB3315
A17R8	0686-1055	1	1	RESISTOR 1M 5% .5W CC TC=0+1000	01121	EB1055
A17R9	0686-2245	3	1	RESISTOR 220K 5% .5W CC TC=0+882	01121	EB2245

See introduction to this section for ordering information.
 * Indicates factory selected value.

Table 6-3. Replaceable Parts (continued)

Reference Designator	HP Part Number	C D	Qty.	Description	Mfr Code	Mfr Part Number
A20	04194-66520	4	1	RANGE RESISTOR BOARD ASSEMBLY	28480	04194-66520
A20C1	0160-4808	4	6	CAPACITOR-FXD 470PF +-5% 100VDC CER	28480	0160-4808
A20C2	0180-3469	3	38	CAPACITOR-FXD 100UF +-20% 25VDC AL	28480	0180-3469
A20C3	0180-3363	6	23	CAPACITOR-FXD 22UF +-20% 25VDC AL	28480	0180-3363
A20C4	0180-3469	3		CAPACITOR-FXD 100UF +-20% 25VDC AL	28480	0180-3469
A20C5	0160-5138	5	2	CAPACITOR-FXD 0.022UF	28480	0160-5138
A20C6	0160-4822	2	6	CAPACITOR-FXD 1000PF +-5% 100VDC CER	28480	0160-4822
A20C7	0160-0127	4	29	CAPACITOR-FXD 1UF +- 20% 25V	28480	0160-0127
A20C8	0160-4832	4		CAPACITOR-FXD .01UF +-10% 100VDC CER	28480	0160-4832
A20C9	0160-3879	4	4	CAPACITOR-FXD .01UF +-20% 100VDC CER	28480	0160-3879
A20C10	0160-3879	4		CAPACITOR-FXD .01UF +-20% 100VDC CER	28480	0160-3879
A20C11	0160-4822	2		CAPACITOR-FXD 1000PF +-5% 100VDC CER	28480	0160-4822
A20C12	0160-4835	7	6	CAPACITOR-FXD .1UF +-10% 50VDC CER	28480	0160-4835
A20C13	0160-4801	7	6	CAPACITOR-FXD 100PF +-5% 100VDC CER	28480	0160-4801
A20C14	0160-4822	2		CAPACITOR-FXD 1000PF +-5% 100VDC CER	28480	0160-4822
A20C15	0180-3469	3		CAPACITOR-FXD 100UF +-20% 25VDC AL	28480	0180-3469
A20C16	0180-3469	3		CAPACITOR-FXD 100UF +-20% 25VDC AL	28480	0180-3469
A20C17	0180-3469	3		CAPACITOR-FXD 100UF +-20% 25VDC AL	28480	0180-3469
A20C18	0180-3469	3		CAPACITOR-FXD 100UF +-20% 25VDC AL	28480	0180-3469
A20C19	0180-3469	3		CAPACITOR-FXD 100UF +-20% 25VDC AL	28480	0180-3469
A20C20	0180-3469	3		CAPACITOR-FXD 100UF +-20% 25VDC AL	28480	0180-3469
A20C21	0160-4832	4		CAPACITOR-FXD .01UF +-10% 100VDC CER	28480	0160-4832
A20C22	0180-3469	3		CAPACITOR-FXD 100UF +-20% 25VDC AL	28480	0180-3469
A20C23	0180-3469	3		CAPACITOR-FXD 100UF +-20% 25VDC AL	28480	0180-3469
A20C24	0160-4832	4		CAPACITOR-FXD .01UF +-10% 100VDC CER	28480	0160-4832
A20C25	0160-4832	4		CAPACITOR-FXD .01UF +-10% 100VDC CER	28480	0160-4832
A20C26	0160-4832	4		CAPACITOR-FXD .01UF +-10% 100VDC CER	28480	0160-4832
A20C27	0160-4832	4		CAPACITOR-FXD .01UF +-10% 100VDC CER	28480	0160-4832
A20C28	0160-4832	4		CAPACITOR-FXD .01UF +-10% 100VDC CER	28480	0160-4832
A20C29	0160-4832	4		CAPACITOR-FXD .01UF +-10% 100VDC CER	28480	0160-4832
A20C30	0160-4832	4		CAPACITOR-FXD .01UF +-10% 100VDC CER	28480	0160-4832
A20C31	0180-3469	3		CAPACITOR-FXD 100UF +-20% 25VDC AL	28480	0180-3469
A20C32	0180-3469	3		CAPACITOR-FXD 100UF +-20% 25VDC AL	28480	0180-3469
A20C33	0180-3469	3		CAPACITOR-FXD 100UF +-20% 25VDC AL	28480	0180-3469
A20C34	0180-3469	3		CAPACITOR-FXD 100UF +-20% 25VDC AL	28480	0180-3469
A20C35	0160-5498	0		CAPACITOR-FXD .01UF	28480	0160-5498
A20C36	0180-3469	3		CAPACITOR-FXD 100UF +-20% 25VDC AL	28480	0180-3469
A20C37	0160-4832	4		CAPACITOR-FXD .01UF +-10% 100VDC CER	28480	0160-4832
A20C38	0160-4832	4		CAPACITOR-FXD .01UF +-10% 100VDC CER	28480	0160-4832
A20C39	0160-4822	2		CAPACITOR-FXD 1000PF +-5% 100VDC CER	28480	0160-4822
A20C40	0180-3469	3		CAPACITOR-FXD 100UF +-20% 25VDC AL	28480	0180-3469
A20C41	0160-4791	4	1	CAPACITOR-FXD 10PF +-5% 100VDC CER 0+-30	28480	0160-4791
A20C42	0160-4834	6	1	CAPACITOR-FXD .047UF +-10% 100VDC CER	28480	0160-4834
A20C43	0180-3363	6		CAPACITOR-FXD 22UF +-20% 25VDC AL	28480	0180-3363
A20C44	0180-3363	6		CAPACITOR-FXD 22UF +-20% 25VDC AL	28480	0180-3363
A20C45	0180-3469	3		CAPACITOR-FXD 100UF +-20% 25VDC AL	28480	0180-3469
A20C46	0180-3363	6		CAPACITOR-FXD 22UF +-20% 25VDC AL	28480	0180-3363
A20C47	0180-3469	3		CAPACITOR-FXD 100UF +-20% 25VDC AL	28480	0180-3469

See introduction to this section for ordering information.
 * Indicates factory selected value.

Table 6-3. Replaceable Parts (continued)

Reference Designator	HP Part Number	C D	Qty.	Description	Mfr Code	Mfr Part Number
A20C48	0160-4808	4		CAPACITOR-FXD 470PF +-5% 100VDC CER	28480	0160-4808
A20C49	0160-3879	4		CAPACITOR-FXD .01UF +-20% 100VDC CER	28480	0160-3879
A20C50	0160-3879	4		CAPACITOR-FXD .01UF +-20% 100VDC CER	28480	0160-3879
A20C51	0160-0127	4		CAPACITOR-FXD 1UF +-20% 25V	28480	0160-0127
A20C52	0160-4832	4		CAPACITOR-FXD .01UF +-10% 100VDC CER	28480	0160-4832
A20C53	0160-5138	5		CAPACITOR-FXD 0.022UF	28480	0160-5138
A20C54	0160-4835	7		CAPACITOR-FXD .1UF +-10% 50VDC CER	28480	0160-4835
A20C55	0160-4801	7		CAPACITOR-FXD 100PF +-5% 100VDC CER	28480	0160-4801
A20C56	0160-4822	2		CAPACITOR-FXD 1000PF +-5% 100VDC CER	28480	0160-4822
A20C57	0180-3469	3		CAPACITOR-FXD 100UF +-20% 25VDC AL	28480	0180-3469
A20C58	0180-3469	3		CAPACITOR-FXD 100UF +-20% 25VDC AL	28480	0180-3469
A20C59	0180-3469	3		CAPACITOR-FXD 100UF +-20% 25VDC AL	28480	0180-3469
A20C60	0180-3469	3		CAPACITOR-FXD 100UF +-20% 25VDC AL	28480	0180-3469
A20C61	0160-4832	4		CAPACITOR-FXD .01UF +-10% 100VDC CER	28480	0160-4832
A20C62	0180-3469	3		CAPACITOR-FXD 100UF +-20% 25VDC AL	28480	0180-3469
A20C63	0180-3469	3		CAPACITOR-FXD 100UF +-20% 25VDC AL	28480	0180-3469
A20C64	0160-4832	4		CAPACITOR-FXD .01UF +-10% 100VDC CER	28480	0160-4832
A20C65	0160-4801	7		CAPACITOR-FXD 100PF +-5% 100VDC CER	28480	0160-4801
A20C66	0160-4835	7		CAPACITOR-FXD .1UF +-10% 50VDC CER	28480	0160-4835
A20C67	0160-4801	7		CAPACITOR-FXD 100PF +-5% 100VDC CER	28480	0160-4801
A20C68	0160-4832	4		CAPACITOR-FXD .01UF +-10% 100VDC CER	28480	0160-4832
A20C69	0160-4832	4		CAPACITOR-FXD .01UF +-10% 100VDC CER	28480	0160-4832
A20C70	0160-4832	4		CAPACITOR-FXD .01UF +-10% 100VDC CER	28480	0160-4832
A20C71	0160-4832	4		CAPACITOR-FXD .01UF +-10% 100VDC CER	28480	0160-4832
A20C72	0160-4832	4		CAPACITOR-FXD .01UF +-10% 100VDC CER	28480	0160-4832
A20C73	0160-4832	4		CAPACITOR-FXD .01UF +-10% 100VDC CER	28480	0160-4832
A20C74	0160-4808	4		CAPACITOR-FXD 470PF +-5% 100VDC CER	28480	0160-4808
A20C75	0160-4832	4		CAPACITOR-FXD .01UF +-10% 100VDC CER	28480	0160-4832
A20C76	0160-4832	4		CAPACITOR-FXD .01UF +-10% 100VDC CER	28480	0160-4832
A20C77	0160-4832	4		CAPACITOR-FXD .01UF +-10% 100VDC CER	28480	0160-4832
A20C78	0160-4832	4		CAPACITOR-FXD .01UF +-10% 100VDC CER	28480	0160-4832
A20C79	0160-4808	4		CAPACITOR-FXD 470PF +-5% 100VDC CER	28480	0160-4808
A20C80	0160-4808	4		CAPACITOR-FXD 470PF +-5% 100VDC CER	28480	0160-4808
A20C81	0160-4808	4		CAPACITOR-FXD 470PF +-5% 100VDC CER	28480	0160-4808
A20C82	0160-4835	7		CAPACITOR-FXD .1UF +-10% 50VDC CER	28480	0160-4835
A20C83	0180-3363	6		CAPACITOR-FXD 22UF +-20% 25VDC AL	28480	0180-3363
A20C84	0180-3363	6		CAPACITOR-FXD 22UF +-20% 25VDC AL	28480	0180-3363
A20C85	0180-3363	6		CAPACITOR-FXD 22UF +-20% 25VDC AL	28480	0180-3363
A20C86	0180-3363	6		CAPACITOR-FXD 22UF +-20% 25VDC AL	28480	0180-3363
A20C87	0180-3363	6		CAPACITOR-FXD 22UF +-20% 25VDC AL	28480	0180-3363
A20C88	0180-3472	8	2	CAPACITOR-FXD 1000UF +-20% 25VDC AL	28480	0180-3472
A20C89	0180-3472	8		CAPACITOR-FXD 1000UF +-20% 25VDC AL	28480	0180-3472
A20C90	0160-4822	2		CAPACITOR-FXD 1000PF +-5% 100VDC CER	28480	0160-4822
A20C91	0160-4835	7		CAPACITOR-FXD .1UF +-10% 50VDC CER	28480	0160-4835
A20C92	0160-4835	7		CAPACITOR-FXD .1UF +-10% 50VDC CER	28480	0160-4835
A20C93	0180-3469	3		CAPACITOR-FXD 100UF +-20% 25VDC AL	28480	0180-3469
A20C94	0180-3469	3		CAPACITOR-FXD 100UF +-20% 25VDC AL	28480	0180-3469
A20C95	0160-4805	3	1	CAPACITOR-FXD 47PF +-5% 100V	28480	0160-4805
A20C96	0180-3363	6		CAPACITOR-FXD 22UF +-20% 25VDC AL	28480	0180-3363

See introduction to this section for ordering information.
 * Indicates factory selected value.

Table 6-3. Replaceable Parts (continued)

Reference Designator	HP Part Number	C D	Qty.	Description	Mfr Code	Mfr Part Number
A20C97	0160-4801	7		CAPACITOR-FXD 100PF +-5% 100VDC CER	28480	0160-4801
A20C98	0180-3363	6		CAPACITOR-FXD 22UF +-20% 25VDC AL	28480	0180-3363
A20C99	0180-3469	3		CAPACITOR-FXD 100UF +-20% 25VDC AL	28480	0180-3469
A20C100	0180-3469	3		CAPACITOR-FXD 100UF +-20% 25VDC AL	28480	0180-3469
A20C101	0180-3363	6		CAPACITOR-FXD 22UF +-20% 25VDC AL	28480	0180-3363
A20C102	0180-3469	3		CAPACITOR-FXD 100UF +-20% 25VDC AL	28480	0180-3469
A20C103	0180-3469	3		CAPACITOR-FXD 100UF +-20% 25VDC AL	28480	0180-3469
A20C104	0180-3469	3		CAPACITOR-FXD 100UF +-20% 25VDC AL	28480	0180-3469
A20C105	0180-3469	3		CAPACITOR-FXD 100UF +-20% 25VDC AL	28480	0180-3469
A20C106	0180-3363	6		CAPACITOR-FXD 22UF +-20% 25VDC AL	28480	0180-3363
A20C107	0180-3363	6		CAPACITOR-FXD 22UF +-20% 25VDC AL	28480	0180-3363
A20C108	0180-3363	6		CAPACITOR-FXD 22UF +-20% 25VDC AL	28480	0180-3363
A20C109	0180-3363	6		CAPACITOR-FXD 22UF +-20% 25VDC AL	28480	0180-3363
A20C110	0180-3363	6		CAPACITOR-FXD 22UF +-20% 25VDC AL	28480	0180-3363
A20C111	0180-3363	6		CAPACITOR-FXD 22UF +-20% 25VDC AL	28480	0180-3363
A20C112	0180-3469	3		CAPACITOR-FXD 100UF +-20% 25VDC AL	28480	0180-3469
A20C113	0180-3469	3		CAPACITOR-FXD 100UF +-20% 25VDC AL	28480	0180-3469
A20C114	0180-3469	3		CAPACITOR-FXD 100UF +-20% 25VDC AL	28480	0180-3469
A20C115	0180-3469	3		CAPACITOR-FXD 100UF +-20% 25VDC AL	28480	0180-3469
A20C116	0180-3363	6		CAPACITOR-FXD 22UF +-20% 25VDC AL	28480	0180-3363
A20C117	0180-3363	6		CAPACITOR-FXD 22UF +-20% 25VDC AL	28480	0180-3363
A20C118	0180-3363	6		CAPACITOR-FXD 22UF +-20% 25VDC AL	28480	0180-3363
A20C119	0180-3363	6		CAPACITOR-FXD 22UF +-20% 25VDC AL	28480	0180-3363
A20C120	0180-3363	6		CAPACITOR-FXD 22UF +-20% 25VDC AL	28480	0180-3363
A20C121	0180-3469	3		CAPACITOR-FXD 100UF +-20% 25VDC AL	28480	0180-3469
A20C122	0160-4832	4		CAPACITOR-FXD .01UF +-10% 100VDC CER	28480	0160-4832
A20C123	0180-3469	3		CAPACITOR-FXD 100UF +-20% 25VDC AL	28480	0180-3469
A20C124	0160-4832	4		CAPACITOR-FXD .01UF +-10% 100VDC CER	28480	0160-4832
A20C125	0160-4832			CAPACITOR-FXD .01UF +-10% .25VDC CER	28480	0160-4832
A20C126	0160-4832			CAPACITOR-FXD .01UF +-10% 100VDC CER	28480	0160-4832
A20C127	0160-4803		1	CAPACITOR-FXD 68PF		
A20C128	0160-4801			CAPACITOR-FXD 100PF +-5% 100VDC	28480	0160-4801
A20CR1	1901-1065	2	4	DIODE-PWR RECT 1N4936 400V 1A 200NS	14936	1N4936
A20CR2	1901-1065	2		DIODE-PWR RECT 1N4936 400V 1A 200NS	14936	1N4936
A20CR3	1901-0050	3	12	DIODE-SWITCHING 80V 200MA 2NS DO-35	28480	1901-0050
A20CR4	1901-0050	3		DIODE-SWITCHING 80V 200MA 2NS DO-35	28480	1901-0050
A20CR5	1902-0946	8	4	DIODE-ZNR 3.3V 5% DO-35 PD=.4W TC=-.039%	28480	1902-0946
A20CR6	1902-0946	8		DIODE-ZNR 3.3V 5% DO-35 PD=.4W TC=-.039%	28480	1902-0946
A20CR7	1901-0050	3		DIODE-SWITCHING 80V 200MA 2NS DO-35	28480	1901-0050
A20CR8	1901-0050	3		DIODE-SWITCHING 80V 200MA 2NS DO-35	28480	1901-0050
A20CR9	1901-0050	3		DIODE-SWITCHING 80V 200MA 2NS DO-35	28480	1901-0050
A20CR10	1901-0050	3		DIODE-SWITCHING 80V 200MA 2NS DO-35	28480	1901-0050
A20CR11	1901-0050	3		DIODE-SWITCHING 80V 200MA 2NS DO-35	28480	1901-0050
A20CR12	1902-0953	7	10	DIODE-ZNR 6.2V 5% DO-35 PD=.4W TC=+.053%	28480	1902-0953
A20CR13	1902-0953	7		DIODE-ZNR 6.2V 5% DO-35 PD=.4W TC=+.053%	28480	1902-0953
A20CR14	1901-1065	2		DIODE-PWR RECT 1N4936 400V 1A 200NS	14936	1N4936
A20CR15	1901-1065	2		DIODE-PWR RECT 1N4936 400V 1A 200NS	14936	1N4936
A20CR16	1901-0050	3		DIODE-SWITCHING 80V 200MA 2NS DO-35	28480	1901-0050
A20CR17	1901-0050	3		DIODE-SWITCHING 80V 200MA 2NS DO-35	28480	1901-0050

See introduction to this section for ordering information.
 * Indicates factory selected value.

Table 6-3. Replaceable Parts (continued)

Reference Designator	HP Part Number	C D	Qty.	Description	Mfr Code	Mfr Part Number
A20CR18	1901-0050	3		DIODE-SWITCHING 80V 200MA 2NS DO-35	28480	1901-0050
A20CR19	1902-0946	8		DIODE-ZNR 3.3V 5% DO-35 PD=.4W TC=-.039%	28480	1902-0946
A20CR20	1902-0946	8		DIODE-ZNR 3.3V 5% DO-35 PD=.4W TC=-.039%	28480	1902-0946
A20CR21	1901-0050	3		DIODE-SWITCHING 80V 200MA 2NS DO-35	28480	1901-0050
A20CR22	1901-0050	3		DIODE-SWITCHING 80V 200MA 2NS DO-35	28480	1901-0050
A20CR23	1902-0953	7		DIODE-ZNR 6.2V 5% DO-35 PD=.4W TC=+.053%	28480	1902-0953
A20CR24	1902-0953	7		DIODE-ZNR 6.2V 5% DO-35 PD=.4W TC=+.053%	28480	1902-0953
A20CR25	1902-0953	7		DIODE-ZNR 6.2V 5% DO-35 PD=.4W TC=+.053%	28480	1902-0953
A20CR26	1902-0953	7		DIODE-ZNR 6.2V 5% DO-35 PD=.4W TC=+.053%	28480	1902-0953
A20CR27	1902-0953	7		DIODE-ZNR 6.2V 5% DO-35 PD=.4W TC=+.053%	28480	1902-0953
A20CR28	1902-0953	7		DIODE-ZNR 6.2V 5% DO-35 PD=.4W TC=+.053%	28480	1902-0953
A20CR29	1902-0953	7		DIODE-ZNR 6.2V 5% DO-35 PD=.4W TC=+.053%	28480	1902-0953
A20CR30	1902-0953	7		DIODE-ZNR 6.2V 5% DO-35 PD=.4W TC=+.053%	28480	1902-0953
A20J1	1250-0257	6	5	CONNECTOR-RF SMB M PC 50 OHM	28480	1250-0257
A20J2	1200-0541	1	1	SOCKET-IC 24-CONT DIP DIP-SLDR	28480	1200-0541
A20J3	1250-0257	6		CONNECTOR-RF SMB M PC 50 OHM	28480	1205-0257
A20J4	1251-3004	4	1	CONNECTOR 40-PIN M RECTANGULAR	28480	1251-3004
A20J5	1250-0257	6		CONNECTOR-RF SMB M PC 50 OHM	28480	1250-0257
A20J6	1250-0257	6		CONNECTOR-RF SMB M PC 50 OHM	28480	1250-0257
A20J7	1250-0257	6		CONNECTOR-RF SMB M PC 50 OHM	28480	1250-0257
A20J8	1251-4938	5	1	CONNECTOR 3-PIN M METRIC POST TYPE	28480	1251-4938
A20J9	1251-4484	6	2	CONNECTOR 4-PIN M POST TYPE	28480	1251-4484
A20J10	1251-4484	6		CONNECTOR 4-PIN M POST TYPE	28480	1251-4484
A20K1	0490-1485	6	3	RELAY SW	28480	0490-1485
A20K2	0490-1485	6		RELAY SW	28480	0490-1485
A20K3	0490-1485	6		RELAY SW	28480	0490-1485
A20L1	9140-0114	4	11	INDUCTOR RF-CH-MLD 10UH 10% .166DX.385LG	28480	9140-0114
A20L2	9100-2259	6	1	INDUCTOR RF-CH-MLD 1.5UH 10%	28480	9100-2259
A20L3	9140-0114	4		INDUCTOR RF-CH-MLD 10UH 10% .166DX.385LG	28480	9140-0114
A20L4	9140-0114	4		INDUCTOR RF-CH-MLD 10UH 10% .166DX.385LG	28480	9140-0114
A20L5	9140-0114	4		INDUCTOR RF-CH-MLD 10UH 10% .166DX.385LG	28480	9140-0114
A20L6	9140-0114	4		INDUCTOR RF-CH-MLD 10UH 10% .166DX.385LG	28480	9140-0114
A20L7	9140-0114	4		INDUCTOR RF-CH-MLD 10UH 10% .166DX.385LG	28480	9140-0114
A20L8	9140-0114	4		INDUCTOR RF-CH-MLD 10UH 10% .166DX.385LG	28480	9140-0114
A20L9	9140-0114	4		INDUCTOR RF-CH-MLD 10UH 10% .166DX.385LG	28480	9140-0114
A20L10	9140-0114	4		INDUCTOR RF-CH-MLD 10UH 10% .166DX.385LG	28480	9140-0114
A20L11		4		NOT ASSIGNED		
A20L12	9140-0114	4		INDUCTOR RF-CH-MLD 10UH 10% .166DX.385LG	28480	9140-0114
A20L13	9140-0114	4		INDUCTOR RF-CH-MLD 10UH 10% .166DX.385LG	28480	9140-0114
A20L14				NOT ASSIGNED		
A20L15	9140-0671	8	2	INDUCTOR 470UH 20%	28480	9140-0671
A20L16	9140-0671	8		INDUCTOR 470UH 20%	28480	9140-0671
A20Q1	1855-0386	9	6	TRANSISTOR J-FET 2N4392 N-CHAN D-MODE	04713	2N4392
A20Q2	1855-0386	9		TRANSISTOR J-FET 2N4392 N-CHAN D-MODE	04713	2N4392
A20Q3	1853-0036	2	4	TRANSISTOR PNP SI PD=310MW FT=250MHZ	28480	1853-0036
A20Q4	1855-0386	9		TRANSISTOR J-FET 2N4392 N-CHAN D-MODE	04713	2N4392
A20Q5	1854-1074	2	2	TRANSISTOR NPN SI PD=200MW FT=.03HZ	28480	1854-1074
A20Q6	1854-1074	2		TRANSISTOR NPN SI PD=200MW FT=.03HZ	28480	1854-1074
A20Q7	1854-0637	1	3	TRANSISTOR NPN 2N2219A SI TO-5 PD=800MW	01295	2N2219A

See introduction to this section for ordering information.
 * Indicates factory selected value.

Table 6-3. Replaceable Parts (continued)

Reference Designator	HP Part Number	C D	Qty.	Description	Mfr Code	Mfr Part Number
A20Q8	1853-0314	9	3	TRANSISTOR PNP 2N2905A SI TO-39 PD=600MW	04713	2N2905A
A20Q9	1854-0637	1		TRANSISTOR NPN 2N2219A SI TO-5 PD=800MW	01295	2N2219A
A20Q10	1853-0314	9		TRANSISTOR PNP 2N2905A SI TO-39 PD=600MW	04713	2N2905A
A20Q11	1853-0036	2		TRANSISTOR PNP SI PD=310MW FT=250MHZ	28480	1853-0036
A20Q12	1855-0386	9		TRANSISTOR J-FET 2N4392 N-CHAN D-MODE	04713	2N4392
A20Q13	1854-0247	9	2	TRANSISTOR NPN SI TO-39 PD=1W FT=800MHZ	28480	1854-0247
A20Q14	1853-0036	2		TRANSISTOR PNP SI PD=310MW FT=250MHZ	28480	1853-0036
A20Q15	1855-0386	9		TRANSISTOR J-FET 2N4392 N-CHAN D-MODE	04713	2N4392
A20Q16	1855-0386	9		TRANSISTOR J-FET 2N4392 N-CHAN D-MODE	04713	2N4392
A20Q17	1854-0637	1		TRANSISTOR NPN 2N2219A SI TO-5 PD=800MW	01295	2N2219A
A20Q18	1853-0314	9		TRANSISTOR PNP 2N2905A SI TO-39 PD=600MW	04713	2N2905A
A20Q19	1854-0247	9		TRANSISTOR NPN SI TO-39 PD=1W FT=800MHZ	28480	1854-0247
A20Q20	1853-0293	3	1	TRANSISTOR PNP 2N5583 SI TO-39 PD=1W	04713	2N5583
A20Q21	1853-0018	0	2	TRANSISTOR PNP SI TO-72 PD=200MW FT=1GHZ	28480	1853-0018
A20Q22	1853-0018	0		TRANSISTOR PNP SI TO-72 PD=200MW FT=1GHZ	28480	1853-0018
A20Q23	1854-0345	8	2	TRANSISTOR NPN 2N5179 SI TO-72 PD=200MW	04713	2N5179
A20Q24	1854-0345	8		TRANSISTOR NPN 2N5179 SI TO-72 PD=200MW	04713	2N5179
A20Q25	1853-0036	2		TRANSISTOR PNP SI PD=310MW FT=250MHZ	28480	1853-0036
A20Q26	1853-0084	0	1	TRANSISTOR PNP 2N4918 SI PD=30W FT=3MHZ	04713	2N4918
A20Q27	1854-0215	1	1	TRANSISTOR NPN SI PD=350MW FT=300MHZ	04713	2N3904
A20Q28	1854-0389	0	1	TRANSISTOR NPN 2N4922 SI PD=30W FT=3MHZ	04713	2N4922
A20R1	0757-0442	9	27	RESISTOR 10K 1% .125W F TC=0+-100	24546	C4-1/8-T0-1002-F
A20R2	0757-0416	7	8	RESISTOR 511 1% .125W F TC=0+-100	24546	C4-1/8-T0-511R-F
A20R3	0698-8827	4	13	RESISTOR 1M 1% .125W F TC=0+-100	28480	0698-8827
A20R4	0757-0465	6	16	RESISTOR 100K 1% .125W F TC=0+-100	24546	C4-1/8-T0-1003-F
A20R5	0757-0442	9		RESISTOR 10K 1% .125W F TC=0+-100	24546	C4-1/8-T0-1002-F
A20R6	0757-0442	9		RESISTOR 10K 1% .125W F TC=0+-100	24546	C4-1/8-T0-1002-F
A20R7	0757-0465	6		RESISTOR 100K 1% .125W F TC=0+-100	24546	C4-1/8-T0-1003-F
A20R8	0757-0280	3	0	RESISTOR 1K 1% .125W F TC=0+-100	24546	C4-1/8-T0-1001-F
A20R9	0698-8827	4		RESISTOR 1M 1% .125W F TC=0+-100	28480	0698-8827
A20R10	0757-0465	4		RESISTOR 100K 1% .125W F TC=0+-100	28480	0757-0465
A20R11	0757-0465	4		RESISTOR 100K 1% .125W F TC=0+-100	28480	0757-0465
A20R12	0757-0465	4		RESISTOR 100K 1% .125W F TC=0+-100	28480	0757-0465
A20R13	0757-0346	2	2	RESISTOR 10 1% .125W F TC=0+-100	24546	C4-1/8-T0-10R0-F
A20R14	0757-0278	9	4	RESISTOR 1.78K 1% .125W F TC=0+-100	24546	C4-1/8-T0-1781-F
A20R15	0757-0416	7		RESISTOR 511 1% .125W F TC=0+-100	24546	C4-1/8-T0-511R-F
A20R16	0757-0422	3		RESISTOR 10K 1% .125W F TC=0+-100	24546	C4-1/8-T0-1002-F
A20R17	0757-0465	4		RESISTOR 100K 1% .125W F TC=0+-100	28480	0757-0465
A20R18	0757-0465	4		RESISTOR 100K 1% .125W F TC=0+-100	28480	0757-0465
A20R19	0757-0442	9		RESISTOR 10K 1% .125W F TC=0+-100	24546	C4-1/8-T0-1002-F
A20R20	0757-0442	9		RESISTOR 10K 1% .125W F TC=0+-100	24546	C4-1/8-T0-1002-F
A20R21	0757-0442	9		RESISTOR 10K 1% .125W F TC=0+-100	24546	C4-1/8-T0-1002-F
A20R22	0698-3452	1	1	RESISTOR 147K 1% .125W F TC=0+-100	24546	C4-1/8-T0-1473-F
A20R23	0757-0280	3		RESISTOR 1K 1% .125W F TC=0+-100	24546	C4-1/8-T0-1001-F
A20R24	0757-0461	2	2	RESISTOR 68.1K 1% .125W F TC=0+-100	24546	C4-1/8-T0-6812-F
A20R25	0698-3155	1	2	RESISTOR 4.64K 1% .125W F TC=0+-100	24546	C4-1/8-T0-4641-F
A20R26	0757-0442	9		RESISTOR 10K 1% .125W F TC=0+-100	24546	C4-1/8-T0-1002-F
A20R27	0757-0439	4		RESISTOR 6.81K	24546	

See introduction to this section for ordering information.
 * Indicates factory selected value.

Table 6-3. Replaceable Parts (continued)

Reference Designator	HP Part Number	C D	Qty.	Description	Mfr Code	Mfr Part Number
A20R28	0757-0439	4		RESISTOR 6.81K	24546	
A20R29	0698-8958	2	1	RESISTOR 511K 1% .125W F TC=0+-100	28480	0698-8958
A20R30	0757-0442	9		RESISTOR 10K 1% .125W F TC=0+-100	24546	C4-1/8-T0-1002-F
A20R31	0757-0442	9		RESISTOR 10K 1% .125W F TC=0+-100	24546	C4-1/8-T0-1002-F
A20R32	0757-0442	9		RESISTOR 10K 1% .125W F TC=0+-100	24546	C4-1/8-T0-1002-F
A20R33	0698-3430	5	29	RESISTOR 21.5 1% .125W F TC=0+-100	03888	PME55-1/8-T0-21R5-F
A20R34	0698-3430	5		RESISTOR 21.5 1% .125W F TC=0+-100	03888	PME55-1/8-T0-21R5-F
A20R35	0698-3430	5		RESISTOR 21.5 1% .125W F TC=0+-100	03888	PME55-1/8-T0-21R5-F
A20R36	0698-3430	5		RESISTOR 21.5 1% .125W F TC=0+-100	03888	PME55-1/8-T0-21R5-F
A20R37	0698-3430	5		RESISTOR 21.5 1% .125W F TC=0+-100	03888	PME55-1/8-T0-21R5-F
A20R38	0698-3430	5		RESISTOR 21.5 1% .125W F TC=0+-100	03888	PME55-1/8-T0-21R5-F
A20R39	0757-0401	0	14	RESISTOR 100 1% .125W F TC=0+-100	24546	C4-1/8-T0-101-F
A20R40	0757-0401	0		RESISTOR 100 1% .125W F TC=0+-100	24546	C4-1/8-T0-101-F
A20R41	0757-0394	0	16	RESISTOR 51.1 1% .125W F TC=0+-100	24546	C4-1/8-T0-51R1-F
A20R42	0757-0442	9		RESISTOR 10K 1% .125W F TC=0+-100	24546	C4-1/8-T0-1002-F
A20R43	0757-0442	9		RESISTOR 10K 1% .125W F TC=0+-100	24546	C4-1/8-T0-1002-F
A20R44	0757-0394	0		RESISTOR 51.1 1% .125W F TC=0+-100	24546	C4-1/8-T0-51R1-F
A20R45	2100-3091	1	1	RESISTOR-TRMR 2K 10% C TOP-ADJ 17-TRN	32997	3292W-1-202
A20R46	0757-0442	9		RESISTOR 10K 1% .125W F TC=0+-100	24546	C4-1/8-T0-1002-F
A20R47	0757-0442	9		RESISTOR 10K 1% .125W F TC=0+-100	24546	C4-1/8-T0-1002-F
A20R48	0757-0438	3		RESISTOR 5.11K 1% .125W F TC=0+-100	24546	C4-1/8-T0-5111-F
A20R49	0698-3430	5		RESISTOR 21.5 1% .125W F TC=0+-100	03888	PME55-1/8-T0-21R5-F
A20R50	0757-0394	0		RESISTOR 51.1 1% .125W F TC=0+-100	24546	C4-1/8-T0-51R1-F
A20R51				NOT ASSIGNED		
A20R52				NOT ASSIGNED		
A20R53	0757-0401	0		RESISTOR 100 1% .125W F TC=0+-100	24546	C4-1/8-T0-101-F
A20R54	0757-0401	0		RESISTOR 100 1% .125W F TC=0+-100	24546	C4-1/8-T0-101-F
A20R55	0757-0394	0		RESISTOR 51.1 1% .125W F TC=0+-100	24546	C4-1/8-T0-51R1-F
A20R56	0757-0401	0		RESISTOR 100 1% .125W F TC=0+-100	24546	C4-1/8-T0-101-F
A20R57	0757-0401	0		RESISTOR 100 1% .125W F TC=0+-100	24546	C4-1/8-T0-101-F
A20R58	0757-0394	0		RESISTOR 51.1 1% .125W F TC=0+-100	24546	C4-1/8-T0-51R1-F
A20R59	0757-0280	3		RESISTOR 1K 1% .125W F TC=0+-100	24546	C4-1/8-T0-1001-F
A20R60	0757-0280	3		RESISTOR 1K 1% .125W F TC=0+-100	24546	C4-1/8-T0-1001-F
A20R61	0757-0394	0		RESISTOR 51.1 1% .125W F TC=0+-100	24546	C4-1/8-T0-51R1-F
A20R62	0698-3430	5		RESISTOR 21.5 1% .125W F TC=0+-100	03888	PME55-1/8-T0-21R5-F
A20R63	0757-0394	0		RESISTOR 51.1 1% .125W F TC=0+-100	24546	C4-1/8-T0-51R1-F
A20R64	0757-0442	9		RESISTOR 10K 1% .125W F TC=0+-100	24546	C4-1/8-T0-1002-F
A20R65	0757-0438	3		RESISTOR 5.11K 1% .125W F TC=0+-100	24546	C4-1/8-T0-5111-F
A20R66	0757-0416	7		RESISTOR 511 1% .125W F TC=0+-100	24546	C4-1/8-T0-511R-F
A20R67	0757-0465	6		RESISTOR 100K 1% .125W F TC=0+-100	28480	0757-0465
A20R68	0757-0465	6		RESISTOR 100K 1% .125W F TC=0+-100	28480	0757-0465
A20R69	0698-0090	7	2	RESISTOR 464 1% .5W F TC=0+-100	28480	0698-0090
A20R70	0698-0090	7		RESISTOR 464 1% .5W F TC=0+-100	28480	0698-0090
A20R71	0757-0465	6		RESISTOR 100K 1% .125W F TC=0+-100	24546	C4-1/8-T0-1003-F
A20R72	0757-0442	9		RESISTOR 10K 1% .125W F TC=0+-100	24546	C4-1/8-T0-1002-F
A20R73	0698-3132	4	2	RESISTOR 261 1% .125W F TC=0+-100	24546	C4-1/8-T0-2610-F
A20R74	0698-3429	2	1	RESISTOR 19.6 1% .125W F TC=0+-100	03888	PME55-1/8-T0-19R6-F
A20R75	0698-3132	4		RESISTOR 261 1% .125W F TC=0+-100	24546	C4-1/8-T0-2610-F
A20R76	0698-3437	2	2	RESISTOR 133 1% .125W F TC=0+-100	24546	C4-1/8-T0-133R-F

See introduction to this section for ordering information.
 * Indicates factory selected value.

Table 6-3. Replaceable Parts (continued)

Reference Designator	HP Part Number	C D	Qty.	Description	Mfr Code	Mfr Part Number
A20R77	0757-0316	6	1	RESISTOR 42.2 1% .125W F TC=0+-100	24546	C4-1/8-T0-42R2-F
A20R78	0698-3437	2		RESISTOR 133 1% .125W F TC=0+-100	24546	C4-1/8-T0-133R-F
A20R79	0757-0398	4	2	RESISTOR 75 1% .125W F TC=0+-100	24546	C4-1/8-T0-75R0-F
A20R80	0757-0402	1	1	RESISTOR 110 1% .125W F TC=0+-100	24546	C4-1/8-T0-111-F
A20R81	0757-0398	4		RESISTOR 75 1% .125W F TC=0+-100	24546	C4-1/8-T0-75R0-F
A20R82	0757-0442	9		RESISTOR 10K 1% .125W F TC=0+-100	24546	C4-1/8-T0-1002-F
A20R83	0757-0346	2		RESISTOR 10 1% .125W F TC=0+-100	24546	C4-1/8-T0-10R0-F
A20R84	0757-0416	7		RESISTOR 511 1% .125W F TC=0+-100	24546	C4-1/8-T0-511R-F
A20R85	0757-0442	3		RESISTOR 10K 1% .125W F TC=0+-10000	24546	C4-1/8-T0-1002-F
A20R86	0757-0278	9		RESISTOR 1.78K 1% .125W F TC=0+-100	24546	C4-1/8-T0-1781-F
A20R87	0757-0280	3		RESISTOR 1K 1% .125W F TC=0+-100	24546	C4-1/8-T0-1001-F
A20R88	0757-0465	6		RESISTOR 100K 1% .125W F TC=0+-100	24546	C4-1/8-T0-1003-F
A20R89	0757-0465	6		RESISTOR 100K 1% .125W F TC=0+-100	28480	0757-0465
A20R90	0757-0465	6		RESISTOR 100K 1% .125W F TC=0+-100	28480	0757-0465
A20R91	0757-0280	3		RESISTOR 1K 1% .125W F TC=0+-100	24546	C4-1/8-T0-1001-F
A20R92	0757-0461	2		RESISTOR 68.1K 1% .125W F TC=0+-100	24546	C4-1/8-T0-6812-F
A20R93	0757-0465	6		RESISTOR 100K 1% .125W F TC=0+-100	28480	0757-0465
A20R94	0757-0465	6		RESISTOR 100K 1% .125W F TC=0+-100	28480	0757-0465
A20R95	0757-0442	9		RESISTOR 10K 1% .125W F TC=0+-100	24546	C4-1/8-T0-1002-F
A20R96	0698-3155	1		RESISTOR 4.64K 1% .125W F TC=0+-100	24546	C4-1/8-T0-4641-F
A20R97	0757-0442	9		RESISTOR 10K 1% .125W F TC=0+-100	24546	C4-1/8-T0-1002-F
A20R98	0698-3430	5		RESISTOR 21.5 1% .125W F TC=0+-100	03888	PME55-1/8-T0-21R5-F
A20R99	0698-3430	5		RESISTOR 21.5 1% .125W F TC=0+-100	03888	PME55-1/8-T0-21R5-F
A20R100	0698-3430	5		RESISTOR 21.5 1% .125W F TC=0+-100	03888	PME55-1/8-T0-21R5-F
A20R101	0698-3430	5		RESISTOR 21.5 1% .125W F TC=0+-100	03888	PME55-1/8-T0-21R5-F
A20R102	0698-3430	5		RESISTOR 21.5 1% .125W F TC=0+-100	03888	PME55-1/8-T0-21R5-F
A20R103	0698-3430	5		RESISTOR 21.5 1% .125W F TC=0+-100	03888	PME55-1/8-T0-21R5-F
A20R104	0757-0394	0		RESISTOR 51.1 1% .125W F TC=0+-100	24546	C4-1/8-T0-51R1-F
A20R105	0757-0401	0		RESISTOR 100 1% .125W F TC=0+-100	24546	C4-1/8-T0-101-F
A20R106	0757-0394	0		RESISTOR 51.1 1% .125W F TC=0+-100	24546	C4-1/8-T0-51R1-F
A20R107	0757-0401	0		RESISTOR 100 1% .125W F TC=0+-100	24546	C4-1/8-T0-101-F
A20R108	0757-0465	6		RESISTOR 100K 1% .125W F TC=0+-100	24546	C4-1/8-T0-1003-F
A20R109	0757-0280	3		RESISTOR 1K 1% .125W F TC=0+-100	24546	C4-1/8-T0-1001-F
A20R110	1810-0037	3	3	NETWORK-RES 16-DIP1.0K OHM X 8	11236	761-3-R1K
A20R111	1810-0037	3		NETWORK-RES 16-DIP1.0K OHM X 8	11236	761-3-R1K
A20R112	1810-0206	8	2	NETWORK-RES 8-SIP10.0K OHM X 7	01121	208A103
A20R113	0757-0442	9		RESISTOR 10K 1% .125W F TC=0+-100	24546	C4-1/8-T0-1002-F
A20R114	0698-3430	5		RESISTOR 21.5 1% .125W F TC=0+-100	03888	PME55-1/8-T0-21R5-F
A20R115	0757-0442	9		RESISTOR 10K 1% .125W F TC=0+-100	24546	C4-1/8-T0-1002-F
A20R116	0757-0442	9		RESISTOR 10K 1% .125W F TC=0+-100	24546	C4-1/8-T0-1002-F
A20R117	0699-2007	2	1	RESISTOR 50 .1% .1W F TC=0+-10	28480	0699-2007
A20R118	0699-2008	3	2	RESISTOR 400 .1% .1W F TC=0+-5	28480	0699-2008
A20R119				NOT ASSIGNED		
A20R120	0699-1758	1	1	RES 3.2K 0.1%	28480	0699-1758
A20R121	0699-2009	4	1	RESISTOR 25K .1% .1W F TC=0+4	28480	0699-2009
A20R122	1810-0037	3		NETWORK-RES 16-DIP1.0K OHM X 8	11236	761-3-R1K
A20R123	0698-3430	5		RESISTOR 21.5 1% .125W F TC=0+-100	03888	PME55-1/8-T0-21R5-F
A20R124	0698-3430	5		RESISTOR 21.5 1% .125W F TC=0+-100	03888	PME55-1/8-T0-21R5-F
A20R125	1810-0206	8		NETWORK-RES 8-SIP10.0K OHM X 7	01121	208A103

See introduction to this section for ordering information.
 * Indicates factory selected value.

Table 6-3. Replaceable Parts (continued)

Reference Designator	HP Part Number	C D	Qty.	Description	Mfr Code	Mfr Part Number
A20R126	0698-3430	5		RESISTOR 21.5 1% .125W F TC=0+-100	03888	PME55-1/8-T0-21R5-F
A20R127	0698-3430	5		RESISTOR 21.5 1% .125W F TC=0+-100	03888	PME55-1/8-T0-21R5-F
A20R128	0757-0280	3		RESISTOR 1K 1% .125W F TC=0+-100	24546	C4-1/8-T0-1001-F
A20R129	0757-0420	3	1	RESISTOR 750 1% .125W F TC=0+-100	24546	C4-1/8-T0-751-F
A20R130	0757-0397	3	2	RESISTOR 68.1 1% .125W F TC=0+-100	24546	C4-1/8-T0-68R1-F
A20R131	0683-0335	2	2	RESISTOR 3.3 5% .25W FC TC=-400/+500	01121	CB33G5
A20R132	0683-0335	2		RESISTOR 3.3 5% .25W FC TC=-400/+500	01121	CB33G5
A20R133	0757-0397	3		RESISTOR 68.1 1% .125W F TC=0+-100	24546	C4-1/8-T0-68R1-F
A20R134	0757-0394	0		RESISTOR 51.1 1% .125W F TC=0+-100	24546	C4-1/8-T0-51R1-F
A20R135	0757-0394	0		RESISTOR 51.1 1% .125W F TC=0+-100	24546	C4-1/8-T0-51R1-F
A20R136	0757-0278	9		RESISTOR 1.78K 1% .125W F TC=0+-100	24546	C4-1/8-T0-1781-F
A20R137	0757-0418	9	2	RESISTOR 619 1% .125W F TC=0+-100	24546	C4-1/8-T0-619R-F
A20R138	0757-0278	9		RESISTOR 1.78K 1% .125W F TC=0+-100	24546	C4-1/8-T0-1781-F
A20R139	0757-0418	9		RESISTOR 619 1% .125W F TC=0+-100	24546	C4-1/8-T0-619R-F
A20R140	0757-0816	1	2	RESISTOR 681 1% .5W F TC=0+-100	28480	0757-0816
A20R141	0698-3430	5		RESISTOR 21.5 1% .125W F TC=0+-100	03888	PME55-1/8-T0-21R5-F
A20R142	0698-4037	0	1	RESISTOR 46.4 +-1% 1/8W		
A20R143	0698-3430	5		RESISTOR 21.5 1% .125W F TC=0+-100	03888	PME55-1/8-T0-21R5-F
A20R144	0757-0280	3		RESISTOR 1K 1% .125W F TC=0+-100	24546	C4-1/8-T0-1001-F
A20R145	0757-0394	0		RESISTOR 51.1 1% .125W F TC=0+-100	24546	C4-1/8-T0-51R1-F
A20R146	0698-3441	8	3	RESISTOR 215 1% .125W F TC=0+-100	24546	C4-1/8-T0-215R-F
A20R147	0757-0421	4	1	RESISTOR 825 1% .125W F TC=0+-100	24546	C4-1/8-T0-825R-F
A20R148	0698-3441	8		RESISTOR 215 1% .125W F TC=0+-100	24546	C4-1/8-T0-215R-F
A20R149	0757-0394	0		RESISTOR 51.1 1% .125W F TC=0+-100	24546	C4-1/8-T0-51R1-F
A20R150	0757-0394	0		RESISTOR 51.1 1% .125W F TC=0+-100	24546	C4-1/8-T0-51R1-F
A20R151	0757-0394	0		RESISTOR 51.1 1% .125W F TC=0+-100	24546	C4-1/8-T0-51R1-F
A20R152	0757-0382	6	2	RESISTOR 16.2 1%		
A20R153	0757-0394	0		RESISTOR 51.1 1% .125W F TC=0+-100	24546	C4-1/8-T0-51R1-F
A20R154	0757-0280	3		RESISTOR 1K 1% .125W F TC=0+-100	24546	C4-1/8-T0-1001-F
A20R155	0757-0382	6		RESISTOR 16.2 1%		
A20R156	0698-3441	8		RESISTOR 215 1% .125W F TC=0+-100	24546	C4-1/8-T0-215R-F
A20R157	0698-0084	9	1	RESISTOR 2.15K 1% .125W F TC=0+-100	24546	C4-1/8-T0-2151-F
A20R158	0698-3334	8	1	RESISTOR 178 1% .5W F TC=0+-100	28480	0698-3334
A20R159	0698-3430	5		RESISTOR 21.5 1% .125W F TC=0+-100	03888	PME55-1/8-T0-21R5-F
A20R160	0757-0816	1		RESISTOR 681 1% .5W F TC=0+-100	28480	0757-0816
A20R161	0698-3430	5		RESISTOR 21.5 1% .125W F TC=0+-100	03888	PME55-1/8-T0-21R5-F
A20R162	0757-0401	0		RESISTOR 100 1% .125W F TC=0+-100	24546	C4-1/8-T0-101-F
A20R163	0757-0401	0		RESISTOR 100 1% .125W F TC=0+-100	24546	C4-1/8-T0-101-F
A20R164	0757-0401	0		RESISTOR 100 1% .125W F TC=0+-100	24546	C4-1/8-T0-101-F
A20R165	0757-0401	0		RESISTOR 100 1% .125W F TC=0+-100	24546	C4-1/8-T0-101-F
A20R166	0698-3430	5		RESISTOR 21.5 1% .125W F TC=0+-100	03888	PME55-1/8-T0-21R5-F
A20R167	0698-3430	5		RESISTOR 21.5 1% .125W F TC=0+-100	03888	PME55-1/8-T0-21R5-F
A20R168	0698-3430	5		RESISTOR 21.5 1% .125W F TC=0+-100	03888	PME55-1/8-T0-21R5-F
A20R169	0757-0416	7		RESISTOR 511 1% .125W F TC=0+-100	24546	C4-1/8-T0-511R-F
A20R170	0698-3430	5		RESISTOR 21.5 1% .125W F TC=0+-100	03888	PME55-1/8-T0-21R5-F
A20R171	0698-3430	5		RESISTOR 21.5 1% .125W F TC=0+-100	03888	PME55-1/8-T0-21R5-F
A20R172	0757-0416	7		RESISTOR 511 1% .125W F TC=0+-100	24546	C4-1/8-T0-511R-F
A20R173	0698-3430	5		RESISTOR 21.5 1% .125W F TC=0+-100	03888	PME55-1/8-T0-21R5-F
A20R174	0757-0401	0		RESISTOR 100 1% .125W F TC=0+-100	24546	C4-1/8-T0-101-F

See introduction to this section for ordering information.
 * Indicates factory selected value.

Table 6-3. Replaceable Parts (continued)

Reference Designator	HP Part Number	C D	Qty.	Description	Mfr Code	Mfr Part Number
A20R175	0757-0401	0		RESISTOR 100 1% .125W F TC=0+-100	24546	C4-1/8-T0-101-F
A20R176	0698-3430	5		RESISTOR 21.5		
A20R177	0757-0416	7		RESISTOR 511 1% .125W F TC=0+-100	24546	C4-1/8-T0-511R-F
A20R178	0757-0416	7		RESISTOR 511 1% .125W F TC=0+-100	24546	C4-1/8-T0-511R-F
A20R179	0698-3430	5		RESISTOR 21.5		
A20R180	0757-0442	9		RESISTOR 10K 1% .125W F TC=0+-100	24546	C4-1/8-T0-1002-F
A20R181	0698-3153	9	1	RESISTOR 3.83K 1% .125W F TC=0+-100	24546	C4-1/8-T0-3831-F
A20R182	0757-0442		2	RESISTOR 10K		
A20R183	0757-0442			RESISTOR 10K		
A20R184				NOT ASSIGNED		
A20R185				NOT ASSIGNED		
A20ST1	3103-0126	4	1	SWITCH THERMAL	28480	3103-0126
A20T1	9100-0879	4	1	XFMR-PLS 113B21	28480	9100-0879
A20U1	04194-81808	3	1	HIC SENSE AMP L	28480	04194-81808
A20U2	04194-81802	7	6	HIC MPX Z-T	28480	04194-81802
A20U3	1826-0035	4	3	IC OP AMP LOW-DRIFT TO-99 PKG	27014	LM308AH
A20U4	1826-0412	1	1	IC COMPARATOR PRCN DUAL 8-DIP-P PKG	27014	LM393N
A20U5	04194-81805	0	1	HIC SENSE AMP R	28480	04194-81805
A20U6	04194-81802	7		HIC MPX Z-T	28480	04194-81802
A20U7	1826-1316	6	1	IC OP AMP LOW-NOISE 8-DIP-C PKG	28480	1826-1316
A20U8	1826-0035	4		IC OP AMP LOW-DRIFT TO-99 PKG	27014	LM308AH
A20U9	1858-0047	5	1	TRANSISTOR ARRAY 16-PIN PLSTC DIP	13606	ULN-2003A
A20U10	1820-1433	6	3	IC SHF-RGTR TTL LS R-S SERIAL-IN PRL-OUT	01295	SN74LS164N
A20U11	1820-1433	6		IC SHF-RGTR TTL LS R-S SERIAL-IN PRL-OUT	01295	SN74LS164N
A20U12	1826-0138	8	2	IC COMPARATOR GP QUAD 14-DIP-P PKG	01295	LM339N
A20U13	1820-1433	6		IC SHF-RGTR TTL LS R-S SERIAL-IN PRL-OUT	01295	SN74LS164N
A20U14	1820-1202	7	2	IC GATE TTL LS NAND TPL 3-INP	01295	SN74LS10N
A20U15	1820-1202	7		IC GATE TTL LS NAND TPL 3-INP	01295	SN74LS10N
A20U16	04194-81802	7		HIC MPX Z-T	28480	04194-81802
A20U17	04194-81802	7		HIC MPX Z-T	28480	04194-81802
A20U18	04194-81802	7		HIC MPX Z-T	28480	04194-81802
A20U19	04194-81802	7		HIC MPX Z-T	28480	04194-81802
A20U20	04194-81806	1	4	HIC RANGE SW	28480	04194-81806
A20U21	04194-81806	1		HIC RANGE SW	28480	04194-81806
A20U22	04194-81806	1		HIC RANGE SW	28480	04194-81806
A20U23	04194-81806	1		HIC RANGE SW	28480	04194-81806
A20U24	1826-0138	8		IC COMPARATOR GP QUAD 14-DIP-P PKG	01295	LM339N
A20U25	1826-0035	4		IC OP AMP LOW-DRIFT TO-99 PKG	27014	LM308AH
A20U26	1826-0122	0	1	IC 7805 V RGLTR TO-220	07263	7805UC

See introduction to this section for ordering information.
 * Indicates factory selected value.

Table 6-3. Replaceable Parts (continued)

Reference Designator	HP Part Number	C D	Qty.	Description	Mfr Code	Mfr Part Number
A21	04194-66521	5	1	PROCESS AMPLIFIER BOARD ASSEMBLY	28480	04194-66521
A21A1	04194-66551	1	1	TEST AMP BD ASY	28480	04194-66551
A21A2	04194-66552	2	1	REF AMP BD ASY	28480	04194-66552
A21C1	0160-4833	5	2	CAPACITOR-FXD .022UF +-10% 100VDC CER	28480	0160-4833
A21C2	0160-4805	1	4	CAPACITOR-FXD 47PF +-5% 100VDC CER 0+-30	28480	0160-4805
A21C3	0160-4810	8	1	CAPACITOR-FXD 330PF +-5% 100VDC CER	28480	0160-4810
A21C4	0160-4801	7	1	CAPACITOR-FXD 100PF +-5% 100VDC CER	28480	0160-4801
A21C5	0180-1085	5	31	CAPACITOR-FXD 4.7UF 16VDC TA	28480	0180-1085
A21C6	0180-1085	5		CAPACITOR-FXD 4.7UF 16VDC TA	28480	0180-1085
A21C7	0121-0060	0	1	CAPACITOR-V TRMR-CER 2-8PF 350V PC-MTG	52763	304322 2/8PF NPO
A21C8				NOT ASSIGNED		
A21C8				NOT ASSIGNED		
A21C8				NOT ASSIGNED		
A21C9	0160-4799	2	1	CAPACITOR-FXD 2.2PF +- .25PF 100VDC CER	28480	0160-4799
A21C10	0160-4832	4	9	CAPACITOR-FXD .01UF +-10% 100VDC CER	28480	0160-4832
A21C11	0180-1085	5		CAPACITOR-FXD 4.7UF 16VDC TA	28480	0180-1085
A21C12	0160-4805	1		CAPACITOR-FXD 47PF +-5% 100VDC CER 0+-30	28480	0160-4805
A21C13	0160-4791	4	1	CAPACITOR-FXD 10PF +-5% 100VDC CER 0+-30	28480	0160-4791
A21C14	0180-1085	5		CAPACITOR-FXD 4.7UF 16VDC TA	28480	0180-1085
A21C15				NOT ASSIGNED		
A21C16				NOT ASSIGNED		
A21C17	0160-4832	4		CAPACITOR-FXD .01UF +-10% 100VDC CER	28480	0160-4832
A21C18	0180-1085	5		CAPACITOR-FXD 4.7UF 16VDC TA	28480	0180-1085
A21C19	0180-1085	5		CAPACITOR-FXD 4.7UF 16VDC TA	28480	0180-1085
A21C20	0180-1085	5		CAPACITOR-FXD 4.7UF 16VDC TA	28480	0180-1085
A21C21	0160-4835	7	6	CAPACITOR-FXD .1UF +-10% 50VDC CER	28480	0160-4835
A21C22	0180-1085	5		CAPACITOR-FXD 4.7UF 16VDC TA	28480	0180-1085
A21C23	0160-4835	7		CAPACITOR-FXD .1UF +-10% 50VDC CER	28480	0160-4835
A21C24				NOT ASSIGNED		
A21C25	0160-6344	7	2	CAP 5600PF	28480	0160-6344
A21C26	0160-0127	2	3	CAPACITOR-FXD 1UF +-20% 25VDC CER	28480	0160-0127
A21C27	0160-4805	1		CAPACITOR-FXD 47PF +-5% 100VDC CER 0+-30	28480	0160-4805
A21C28	0160-4832	4		CAPACITOR-FXD .01UF +-10% 100VDC CER	28480	0160-4832
A21C29	0180-1085	5		CAPACITOR-FXD 4.7UF 16VDC TA	28480	0180-1085
A21C30	0160-6344	7		CAP 5600PF	28480	0160-6344
A21C31	0160-6336	7		CAP 2200PF	28480	0160-6336
A21C32	0180-1085	5		CAPACITOR-FXD 4.7UF 16VDC TA	28480	0180-1085
A21C33	0180-0197	8	6	CAPACITOR-FXD 2.2UF +-10% 20VDC TA	56289	150D225X9020A2
A21C34				NOT ASSIGNED		
A21C35	0160-6336	7		CAP 2200PF	28480	0160-6336
A21C36	0160-4813	1	1	CAPACITOR-FXD 180PF +-5% 100VDC CER	28480	0160-4813
A21C37	0180-1085	5		CAPACITOR-FXD 4.7UF 16VDC TA	28480	0180-1085
A21C38	0180-1085	5		CAPACITOR-FXD 4.7UF 16VDC TA	28480	0180-1085
A21C39	0180-0197	8		CAPACITOR-FXD 2.2UF +-10% 20VDC TA	56289	150D225X9020A2
A21C40	0180-0197	8		CAPACITOR-FXD 2.2UF +-10% 20VDC TA	56289	150D225X9020A2
A21C41	0180-0197	8		CAPACITOR-FXD 2.2UF +-10% 20VDC TA	56289	150D225X9020A2
A21C42	0180-0197	8		CAPACITOR-FXD 2.2UF +-10% 20VDC TA	56289	150D225X9020A2
A21C43	0180-0197	8		CAPACITOR-FXD 2.2UF +-10% 20VDC TA	56289	150D225X9020A2

See introduction to this section for ordering information.
* Indicates factory selected value.

Table 6-3. Replaceable Parts (continued)

Reference Designator	HP Part Number	C D	Qty.	Description	Mfr Code	Mfr Part Number	
A21C44	0160-4832		4	CAPACITOR-FXD .01UF +-10% 100VDC CER	28480	0160-4832	
A21C45	0180-3469		3	5	CAPACITOR-FXD 100UF +-20% 25VDC AL	28480	0180-3469
A21C46	0180-1085		5	CAPACITOR-FXD 4.7UF 16VDC TA	28480	0180-1085	
A21C47	0160-4804		0	2	CAPACITOR-FXD 56PF +-5% 100VDC CER 0+-30	28480	0160-4804
A21C48	0160-4807		3	3	CAPACITOR-FXD 33PF +-5% 100VDC CER 0+-30	28480	0160-4807
A21C49	0160-4835		7	CAPACITOR-FXD .1UF +-10% 50VDC CER	28480	0160-4835	
A21C50	0160-4804		0	CAPACITOR-FXD 56PF +-5% 100VDC CER 0+-30	28480	0160-4804	
A21C51	0160-0127		2	CAPACITOR-FXD 1UF +-20% 25VDC CER	28480	0160-0127	
A21C52	0160-0127		2	CAPACITOR-FXD 1UF +-20% 25VDC CER	28480	0160-0127	
A21C53	0160-4807		3	CAPACITOR-FXD 33PF +-5% 100VDC CER 0+-30	28480	0160-4807	
A21C54				NOT ASSIGNED			
A21C55	0180-1085		5	CAPACITOR-FXD 4.7UF 16VDC TA	28480	0180-1085	
A21C56	0160-4832		4	CAPACITOR-FXD .01UF +-10% 100VDC CER	28480	0160-4832	
A21C57	0180-1085		5	CAPACITOR-FXD 4.7UF 16VDC TA	28480	0180-1085	
A21C58	0180-1085		5	CAPACITOR-FXD 4.7UF 16VDC TA	28480	0180-1085	
A21C59	0180-1085		5	CAPACITOR-FXD 4.7UF 16VDC TA	28480	0180-1085	
A21C60	0180-1085		5	CAPACITOR-FXD 4.7UF 16VDC TA	28480	0180-1085	
A21C61	0180-3469		3	CAPACITOR-FXD 100UF +-20% 25VDC AL	28480	0180-3469	
A21C62	0180-1085		5	CAPACITOR-FXD 4.7UF 16VDC TA	28480	0180-1085	
A21C63	0180-1085		5	CAPACITOR-FXD 4.7UF 16VDC TA	28480	0180-1085	
A21C64	0160-4830		2	3	CAPACITOR-FXD 2200PF +-10% 100VDC CER	28480	0160-4830
A21C65	0180-3469		3	CAPACITOR-FXD 100UF +-20% 25VDC AL	28480	0180-3469	
A21C66	0160-4795		8	2	CAPACITOR-FXD 4.7PF +- .5PF 100VDC CER	28480	0160-4795
A21C67	0160-4795		8	CAPACITOR-FXD 4.7PF +- .5PF 100VDC CER	28480	0160-4795	
A21C68	0160-4832		4	CAPACITOR-FXD .01UF +-10% 100VDC CER	28480	0160-4832	
A21C69	0160-4807		3	CAPACITOR-FXD 33PF +-5% 100VDC CER 0+-30	28480	0160-4807	
A21C70				NOT ASSIGNED			
A21C71	0160-4789		0	CAPACITOR-FXD 15PF +-5% 100VDC CER 0+-30	28480	0160-4789	
A21C72	0160-6422		2	1	CAPACITOR 0.1UF 5%	28480	0160-6422
A21C73	0160-4832		4	CAPACITOR-FXD .01UF +-10% 100VDC CER	28480	0160-4832	
A21C74	0160-4835		7	CAPACITOR-FXD .1UF +-10% 50VDC CER	28480	0160-4835	
A21C75	0160-4830		2	CAPACITOR-FXD 2200PF +-10% 100VDC CER	28480	0160-4830	
A21C76	0180-1085		5	CAPACITOR-FXD 4.7UF 16VDC TA	28480	0180-1085	
A21C77	0180-1085		5	CAPACITOR-FXD 4.7UF 16VDC TA	28480	0180-1085	
A21C78	0180-1085		5	CAPACITOR-FXD 4.7UF 16VDC TA	28480	0180-1085	
A21C79	0180-1085		5	CAPACITOR-FXD 4.7UF 16VDC TA	28480	0180-1085	
A21C80				NOT ASSIGNED			
A21C81	0160-4805		1	CAPACITOR-FXD 47PF +-5% 100VDC CER 0+-30	28480	0160-4805	
A21C82	0180-1085		5	CAPACITOR-FXD 4.7UF 16VDC TA	28480	0180-1085	
A21C83	0180-1085		5	CAPACITOR-FXD 4.7UF 16VDC TA	28480	0180-1085	
A21C84	0160-4833		5	CAPACITOR-FXD .022UF +-10% 100VDC CER	28480	0160-4833	
A21C85				NOT ASSIGNED			
A21C86	0160-4822		2	2	CAPACITOR-FXD 1000PF +-5% 100VDC CER	28480	0160-4822
A21C87	0160-4835		7	CAPACITOR-FXD .1UF +-10% 50VDC CER	28480	0160-4835	
A21C88	0160-4835		7	CAPACITOR-FXD .1UF +-10% 50VDC CER	28480	0160-4835	
A21C89	0160-4822		2	CAPACITOR-FXD 1000PF +-5% 100VDC CER	28480	0160-4822	
A21C90	0180-3469		3	CAPACITOR-FXD 100UF +-20% 25VDC AL	28480	0180-3469	
A21C91	0180-3469		3	CAPACITOR-FXD 100UF +-20% 25VDC AL	28480	0180-3469	
A21C92	0180-1085		5	CAPACITOR-FXD 4.7UF 16VDC TA	28480	0180-1085	

See introduction to this section for ordering information.
 * Indicates factory selected value.

Table 6-3. Replaceable Parts (continued)

Reference Designator	HP Part Number	C D	Qty.	Description	Mfr Code	Mfr Part Number
A21C93	0180-1085	5		CAPACITOR-FXD 4.7UF 16VDC TA	28480	0180-1085
A21C94	0160-4830	2		CAPACITOR-FXD 2200PF +-10% 100VDC CER	28480	0160-4830
A21C95	0180-1085	5		CAPACITOR-FXD 4.7UF 16VDC TA	28480	0180-1085
A21C96	0180-1085	5		CAPACITOR-FXD 4.7UF 16VDC TA	28480	0180-1085
A21C97	0180-1085	5		CAPACITOR-FXD 4.7UF 16VDC TA	28480	0180-1085
A21CR1	1901-0050	3	16	DIODE-SWITCHING 80V 200MA 2NS DO-35	28480	1901-0050
A21CR2	1901-0050	3		DIODE-SWITCHING 80V 200MA 2NS DO-35	28480	1901-0050
A21CR3	1901-0050	3		DIODE-SWITCHING 80V 200MA 2NS DO-35	28480	1901-0050
A21CR4	1901-0050	3		DIODE-SWITCHING 80V 200MA 2NS DO-35	28480	1901-0050
A21CR5	1901-0050	3		DIODE-SWITCHING 80V 200MA 2NS DO-35	28480	1901-0050
A21CR6	1901-0050	3		DIODE-SWITCHING 80V 200MA 2NS DO-35	28480	1901-0050
A21CR7	1902-0956	0	1	DIODE-ZNR 8.2V 5% DO-35 PD=.4W TC=+.065%	28480	1902-0956
A21CR8	1901-0050	3		DIODE-SWITCHING 80V 200MA 2NS DO-35	28480	1901-0050
A21CR9	1901-0050	3		DIODE-SWITCHING 80V 200MA 2NS DO-35	28480	1901-0050
A21CR10	1901-0050	3		DIODE-SWITCHING 80V 200MA 2NS DO-35	28480	1901-0050
A21CR11	1901-0050	3		DIODE-SWITCHING 80V 200MA 2NS DO-35	28480	1901-0050
A21CR12	1901-0050	3		DIODE-SWITCHING 80V 200MA 2NS DO-35	28480	1901-0050
A21CR13	1901-0050	3		DIODE-SWITCHING 80V 200MA 2NS DO-35	28480	1901-0050
A21CR14	1901-0050	3		DIODE-SWITCHING 80V 200MA 2NS DO-35	28480	1901-0050
A21CR15	1901-0050	3		DIODE-SWITCHING 80V 200MA 2NS DO-35	28480	1901-0050
A21CR16	1901-0050	3		DIODE-SWITCHING 80V 200MA 2NS DO-35	28480	1901-0050
A21CR17	1901-0050	3		DIODE-SWITCHING 80V 200MA 2NS DO-35	28480	1901-0050
A21E1	0955-0252	9	1	U-WAVE MIXER 250MHZ MAX	28480	0955-0252
A21F1	9135-0277	9	3	FILTER-LOWPASS OPER VOLTAGE:50 VDC MAX	28480	9135-0277
A21F2	9135-0276	8	3	FILTER 002-02	28480	9135-0276
A21F3	9135-0277	9		FILTER-LOWPASS OPER VOLTAGE:50 VDC MAX	28480	9135-0277
A21F4	9135-0276	8		FILTER 002-02	28480	9135-0276
A21F5	9135-0276	8		FILTER 002-02	28480	9135-0276
A21F6	9135-0277	9		FILTER-LOWPASS OPER VOLTAGE:50 VDC MAX	28480	9135-0277
A21J1	1250-0257	1	5	CONNECTOR-RF SMB M PC 50-OHM	28480	1250-0257
A21J2	1200-0541	1	1	SOCKET-IC 24-CONT DIP DIP-SLDR	28480	1200-0541
A21J3	1250-0257	1		CONNECTOR-RF SMB M PC 50-OHM	28480	1250-0257
A21J4	1250-0257	1		CONNECTOR-RF SMB M PC 50-OHM	28480	1250-0257
A21J5	1250-0257	1		CONNECTOR-RF SMB M PC 50-OHM	28480	1250-0257
A21J6	1250-0257	1		CONNECTOR-RF SMB M PC 50-OHM	28480	1250-0257
A21J7	0360-0124	3	16	CONNECTOR-SGL CONT PIN .04-1N-BSC-SZ RND	28480	0360-0124
A21J8	0360-0124	3		CONNECTOR-SGL CONT PIN .04-1N-BSC-SZ RND	28480	0360-0124
A21J9	0360-0124	3		CONNECTOR-SGL CONT PIN .04-1N-BSC-SZ RND	28480	0360-0124
A21J10	0360-0124	3		CONNECTOR-SGL CONT PIN .04-1N-BSC-SZ RND	28480	0360-0124
A21J11	0360-0124	3		CONNECTOR-SGL CONT PIN .04-1N-BSC-SZ RND	28480	0360-0124
A21J12	0360-0124	3		CONNECTOR-SGL CONT PIN .04-1N-BSC-SZ RND	28480	0360-0124
A21J13	0360-0124	3		CONNECTOR-SGL CONT PIN .04-1N-BSC-SZ RND	28480	0360-0124
A21J14	0360-0124	3		CONNECTOR-SGL CONT PIN .04-1N-BSC-SZ RND	28480	0360-0124
A21J15	0360-0124	3		CONNECTOR-SGL CONT PIN .04-1N-BSC-SZ RND	28480	0360-0124
A21J16	0360-0124	3		CONNECTOR-SGL CONT PIN .04-1N-BSC-SZ RND	28480	0360-0124
A21J17	0360-0124	3		CONNECTOR-SGL CONT PIN .04-1N-BSC-SZ RND	28480	0360-0124
A21J18	0360-0124	3		CONNECTOR-SGL CONT PIN .04-1N-BSC-SZ RND	28480	0360-0124
A21J19	0360-0124	3		CONNECTOR-SGL CONT PIN .04-1N-BSC-SZ RND	28480	0360-0124
A21J20	0360-0124	3		CONNECTOR-SGL CONT PIN .04-1N-BSC-SZ RND	28480	0360-0124

See introduction to this section for ordering information.
 * Indicates factory selected value.

Table 6-3. Replaceable Parts (continued)

Reference Designator	HP Part Number	C D	Qty.	Description	Mfr Code	Mfr Part Number
A21J21	0360-0124	3		CONNECTOR-SGL CONT PIN .04-IN-BSC-SZ RND	28480	0360-0124
A21J22	0360-0124	3		CONNECTOR-SGL CONT PIN .04-IN-BSC-SZ RND	28480	0360-0124
A21J23	1200-0796	8	1	SOCKET-IC 8-CONT DIP DIP-SLDR	28480	1200-0796
A21J24	1251-4822			3-PIN CONNECTOR		
A21J25	1251-4822			3-PIN CONNECTOR		
A21J26	1251-4822			3-PIN CONNECTOR		
A21K1	0490-1477	6	1	RELAY	28480	0490-1477
A21L1	9140-1137	3	2	COIL 280UH	28480	9140-1137
A21L2	9140-1138	4	1	COIL 670UH	28480	9140-1138
A21L3	9140-1137	3		COIL 280UH	28480	9140-1137
A21L4	9170-0029	3	14	CORE-SHIELDING BEAD	28480	9170-0029
A21L5	9170-0029	3		CORE-SHIELDING BEAD	28480	9170-0029
A21L6	9140-1093	5	8	COIL 10UH 10%	28480	9140-1093
A21L7	9140-1093	5		COIL 10UH 10%	28480	9140-1093
A21L8	9170-0029	3		CORE-SHIELDING BEAD	28480	9170-0029
A21L9	9170-0029	3		CORE-SHIELDING BEAD	28480	9170-0029
A21L10	9170-0029	3		CORE-SHIELDING BEAD	28480	9170-0029
A21L11	9170-0029	3		CORE-SHIELDING BEAD	28480	9170-0029
A21L12	9170-0029	3		CORE-SHIELDING BEAD	28480	9170-0029
A21L13	9170-0029	3		CORE-SHIELDING BEAD	28480	9170-0029
A21L14	9170-0029	3		CORE-SHIELDING BEAD	28480	9170-0029
A21L15	9100-2247	4	5	INDUCTOR RF-CH-MLD 100NH 10% .105DX.26LG	28480	9100-2247
A21L16	9100-2247	4		INDUCTOR RF-CH-MLD 100NH 10% .105DX.26LG	28480	9100-2247
A21L17	9100-2247	4		INDUCTOR RF-CH-MLD 100NH 10% .105DX.26LG	28480	9100-2247
A21L18	9140-1093	0		COIL 10UH 10%	28480	9140-1093
A21L19	9100-2259	8	13	INDUCTOR RF-CH-MLD 1.5UH 10% .105DX.26LG	28480	9100-2259
A21L20	9140-1093	5		COIL 10UH 10%	28480	9140-1093
A21L21	9100-2259	8		INDUCTOR RF-CH-MLD 1.5UH 10% .105DX.26LG	28480	9100-2259
A21L22	9100-2259	8		INDUCTOR RF-CH-MLD 1.5UH 10% .105DX.26LG	28480	9100-2259
A21L23	9100-2259	8		INDUCTOR RF-CH-MLD 1.5UH 10% .105DX.26LG	28480	9100-2259
A21L31	9100-2259	8		INDUCTOR RF-CH-MLD 1.5UH 10% .105DX.26LG	28480	9100-2259
A21L32	9170-0029	3		CORE-SHIELDING BEAD	28480	9170-0029
A21L33	9170-0029	3		CORE-SHIELDING BEAD	28480	9170-0029
A21L34	9170-0029	3		CORE-SHIELDING BEAD	28480	9170-0029
A21L35	9170-0029	3		CORE-SHIELDING BEAD	28480	9170-0029
A21L36	9140-1093	5		COIL 10UH 10%	28480	9140-1093
A21L37	9100-2259	8		INDUCTOR RF-CH-MLD 1.5UH 10% .105DX.26LG	28480	9100-2259
A21L38	9100-2259	8		INDUCTOR RF-CH-MLD 1.5UH 10% .105DX.26LG	28480	9100-2259
A21L39	9140-1093	5		COIL 10UH 10%	28480	9140-1093
A21L40	9140-1093	5		COIL 10UH 10%	28480	9140-1093
A21L41	9100-2259	8		INDUCTOR RF-CH-MLD 1.5UH 10% .105DX.26LG	28480	9100-2259
A21L42	9100-2259	8		INDUCTOR RF-CH-MLD 1.5UH 10% .105DX.26LG	28480	9100-2259
A21L43	9100-2259	8		INDUCTOR RF-CH-MLD 1.5UH 10% .105DX.26LG	28480	9100-2259
A21Q1	1853-0459	3	1	TRANSISTOR PNP SI PD=625MW FT=200MHZ	28480	1853-0459
A21Q2	1854-0810	2	1	TRANSISTOR NPN SI PD=625MW FT=200MHZ	28480	1854-0810
A21Q3	1855-0386	9	8	TRANSISTOR J-FET 2N4392 N-CHAN D-MODE	04713	2N4392
A21Q4	1855-0386	9		TRANSISTOR J-FET 2N4392 N-CHAN D-MODE	04713	2N4392
A21Q5	1855-0091	3	1	TRANSISTOR J-FET N-CHAN D-MODE SI	28480	1855-0091
A21Q6	1855-0386	9		TRANSISTOR J-FET 2N4392 N-CHAN D-MODE	04713	2N4392

See introduction to this section for ordering information.
 * Indicates factory selected value.

Table 6-3. Replaceable Parts (continued)

Reference Designator	HP Part Number	C D	Qty.	Description	Mfr Code	Mfr Part Number
A21Q7	1855-0386	9		TRANSISTOR J-FET 2N4392 N-CHAN D-MODE	04713	2N4392
A21Q8	1854-1073	1	7	TRANSISTOR NPN SI PD=600MW FT=6.5GHZ	28480	1854-1073
A21Q9	1854-1073	1		TRANSISTOR NPN SI PD=600MW FT=6.5GHZ	28480	1854-1073
A21Q10	1854-1073	1		TRANSISTOR NPN SI PD=600MW FT=6.5GHZ	28480	1854-1073
A21Q11	1854-1073	1		TRANSISTOR NPN SI PD=600MW FT=6.5GHZ	28480	1854-1073
A21Q12	1854-1073	1		TRANSISTOR NPN SI PD=600MW FT=6.5GHZ	28480	1854-1073
A21Q13	1854-0215	1	1	TRANSISTOR NPN SI PD=350MW FT=300MHZ	04713	2N3904
A21Q14	1854-1073	1		TRANSISTOR NPN SI PD=600MW FT=6.5GHZ	28480	1854-1073
A21Q15	1854-0247	9	1	TRANSISTOR NPN SI TO-39 PD=1W FT=800MHZ	28480	1854-0247
A21Q16	1854-1073	1		TRANSISTOR NPN SI PD=600MW FT=6.5GHZ	28480	1854-1073
A21Q17	1855-0386	9		TRANSISTOR J-FET 2N4392 N-CHAN D-MODE	04713	2N4392
A21Q18	1853-0020	4	4	TRANSISTOR PNP SI PD=300MW FT=150MHZ	28480	1853-0020
A21Q19	1855-0386	9		TRANSISTOR J-FET 2N4392 N-CHAN D-MODE	04713	2N4392
A21Q20	1853-0020	4		TRANSISTOR PNP SI PD=300MW FT=150MHZ	28480	1853-0020
A21Q21	1855-0386	9		TRANSISTOR J-FET 2N4392 N-CHAN D-MODE	04713	2N4392
A21Q22	1853-0020	4		TRANSISTOR PNP SI PD=300MW FT=150MHZ	28480	1853-0020
A21Q23	1855-0386	9		TRANSISTOR J-FET 2N4392 N-CHAN D-MODE	04713	2N4392
A21Q24	1853-0020	4		TRANSISTOR PNP SI PD=300MW FT=150MHZ	28480	1853-0020
A21R1	0757-0346	2	12	RESISTOR 10 1% .125W F TC=0+-100	24546	C4-1/8-T0-10R0-F
A21R2	0757-0346	2		RESISTOR 10 1% .125W F TC=0+-100	24546	C4-1/8-T0-10R0-F
A21R3	0757-0199	3	6	RESISTOR 21.5K 1% .125W F TC=0+-100	24546	C4-1/8-T0-2152-F
A21R4	0698-3444	1	5	RESISTOR 316 1% .125W F TC=0+-100	24546	C4-1/8-T0-316R-F
A21R5	0757-0346	2		RESISTOR 10 1% .125W F TC=0+-100	24546	C4-1/8-T0-10R0-F
A21R6	0757-0199	3		RESISTOR 21.5K 1% .125W F TC=0+-100	24546	C4-1/8-T0-2152-F
A21R7	0698-3444	1		RESISTOR 316 1% .125W F TC=0+-100	24546	C4-1/8-T0-316R-F
A21R8	0757-0419	0	2	RESISTOR 681 1% .125W F TC=0+-100	24546	C4-1/8-T0-681R-F
A21R9	0698-0083	8	3	RESISTOR 1.96K 1% .125W F TC=0+-100	24546	C4-1/8-T0-1961-F
A21R10	0757-0416	7	1	RESISTOR 511 1% .125W F TC=0+-100	24546	C4-1/8-T0-511R-F
A21R11	0757-0465	6	3	RESISTOR 100K 1% .125W F TC=0+-100	24546	C4-1/8-T0-1003-F
A21R12	0698-3459	8	4	RESISTOR 383K 1% .125W F TC=0+-100	28480	0698-3459
A21R13	0698-3459	8		RESISTOR 383K 1% .125W F TC=0+-100	28480	0698-3459
A21R14	0757-0280	3	8	RESISTOR 1K 1% .125W F TC=0+-100	24546	C4-1/8-T0-1001-F
A21R15	0698-8827	4	10	RESISTOR 1M 1% .125W F TC=0+-100	28480	0698-8827
A21R16	0757-0459	8	3	RESISTOR 56.2K 1% .125W F TC=0+-100	24546	C4-1/8-T0-5622-F
A21R17	0698-8827	4		RESISTOR 1M 1% .125W F TC=0+-100	28480	0698-8827
A21R18	0698-3459	8		RESISTOR 383K 1% .125W F TC=0+-100	28480	0698-3459
A21R19	0698-3459	8		RESISTOR 383K 1% .125W F TC=0+-100	28480	0698-3459
A21R20	0757-0442	9	18	RESISTOR 10K 1% .125W F TC=0+-100	24546	C4-1/8-T0-1002-F
A21R21	0757-0280	3		RESISTOR 1K 1% .125W F TC=0+-100	24546	C4-1/8-T0-1001-F
A21R22	0757-0465	6		RESISTOR 100K 1% .125W F TC=0+-100	24546	C4-1/8-T0-1003-F
A21R23	0757-0288	1	1	RESISTOR 9.09K 1% .125W F TC=0+-100	19701	MF4C1/8-T0-9091-F
A21R23	0757-0442	9		RESISTOR 10K 1% .125W F TC=0+-100	24546	C4-1/8-T0-1002-F
A21R23	0757-0443	0	1	RESISTOR 11K 1% .125W F TC=0+-100	24546	C4-1/8-T0-1102-F
A21R24	2100-3091	1	2	RESISTOR-TRMR 2K 10% C TOP-ADJ 17-TRN	32997	3292W-1-202
A21R25	0699-1706	6	1	RESISTOR 261 .1% .05W F TC=0+-5	28480	0699-1706
A21R26	0699-1702	2	1	RESISTOR 1.78K .1% .05W F TC=0+-5	28480	0699-1702
A21R27	0698-0084	9	3	RESISTOR 2.15K 1% .125W F TC=0+-100	24546	C4-1/8-T0-2151-F
A21R28	0757-0439	3	1	RESISTOR 6.81K 1% .125W F TC=0+-100	24546	C4-1/8-T0-6811-F

See introduction to this section for ordering information.
* Indicates factory selected value.

Table 6-3. Replaceable Parts (continued)

Reference Designator	HP Part Number	C D	Qty.	Description	Mfr Code	Mfr Part Number
A21R29	0698-0084	9		RESISTOR 2.15K 1% .125W F TC=0+-100	24546	C4-1/8-T0-2151-F
A21R30	0698-3150	6	1	RESISTOR 2.37K 1%		
A21R31	0757-0465	6		RESISTOR 100K 1% .125W F TC=0+-100	24546	C4-1/8-T0-1003-F
A21R32	0757-0441	8	2	RESISTOR 8.25K 1% .125W F TC=0+-100	24546	C4-1/8-T0-8251-F
A21R33	0757-0280	3		RESISTOR 1K 1% .125W F TC=0+-100	24546	C4-1/8-T0-1001-F
A21R34	0757-0280	3		RESISTOR 1K 1% .125W F TC=0+-100	24546	C4-1/8-T0-1001-F
A21R35	0757-0280	3		RESISTOR 1K 1% .125W F TC=0+-100	24546	C4-1/8-T0-1001-F
A21R36	0757-0199	3		RESISTOR 21.5K 1% .125W F TC=0+-100	24546	C4-1/8-T0-2152-F
A21R37	0698-3160	8	3	RESISTOR 31.6K 1% .125W F TC=0+-100	24546	C4-1/8-T0-3162-F
A21R38	0698-0082	7	3	RESISTOR 464 1% .125W F TC=0+-100	24546	C4-1/8-T0-4640-F
A21R39	0757-0274	5	3	RESISTOR 1.21K 1% .125W F TC=0+-100	24546	C4-1/8-T0-1211-F
A21R40	0698-3160	8		RESISTOR 31.6K 1% .125W F TC=0+-100	24546	C4-1/8-T0-3162-F
A21R41	0757-0290	5	1	RESISTOR 6.19K 1% .125W F TC=0+-100	19701	MF4C1/8-T0-6191-F
A21R42	0698-3454	3	1	RESISTOR 215K 1% .125W F TC=0+-100	24546	C4-1/8-T0-2153-F
A21R43	0698-3136	8	1	RESISTOR 17.8K 1% .125W F TC=0+-100	24546	C4-1/8-T0-1782-F
A21R44	0757-0459	8		RESISTOR 56.2K 1% .125W F TC=0+-100	24546	C4-1/8-T0-5622-F
A21R45	0757-0428	1	1	RESISTOR 1.62K 1% .125W F TC=0+-100	24546	C4-1/8-T0-1621-F
A21R46	0698-3160	8		RESISTOR 31.6K 1% .125W F TC=0+-100	24546	C4-1/8-T0-3162-F
A21R47	0698-3430	5	6	RESISTOR 21.5 1% .125W F TC=0+-100	03888	PME55-1/8-T0-21R5-F
A21R48	0698-3430	5		RESISTOR 21.5 1% .125W F TC=0+-100	03888	PME55-1/8-T0-21R5-F
A21R49	0757-0280	3		RESISTOR 1K 1% .125W F TC=0+-100	24546	C4-1/8-T0-1001-F
A21R50	0757-0418	9	1	RESISTOR 619 1% .125W F TC=0+-100	24546	C4-1/8-T0-619R-F
A21R51	0757-0401	0	10	RESISTOR 100 1% .125W F TC=0+-100	24546	C4-1/8-T0-101-F
A21R52	0757-0424	0	2	RESISTOR 1.10K 1% .125W F TC=0+-100	24546	C4-1/8-T0-1101-F
A21R53	0757-0346	2		RESISTOR 10 1% .125W F TC=0+-100	24546	C4-1/8-T0-10R0-F
A21R54	0757-0419	0		RESISTOR 681 1% .125W F TC=0+-100	24546	C4-1/8-T0-681R-F
A21R55	0698-0083	8		RESISTOR 1.96K 1% .125W F TC=0+-100	24546	C4-1/8-T0-1961-F
A21R56	0698-3444	1		RESISTOR 316 1% .125W F TC=0+-100	24546	C4-1/8-T0-316R-F
A21R57	0757-0277	8	4	RESISTOR 49.9 1% .125W F TC=0+-100	24546	C4-1/8-T0-4992-F
A21R58	0698-4037	0	3	RESISTOR 46.4 1% .125W F TC=0+-100	24546	C4-1/8-T0-46R4-F
A21R59	0698-3444	1		RESISTOR 316 1% .125W F TC=0+-100	24546	C4-1/8-T0-316R-F
A21R60	0757-0401	0		RESISTOR 100 1% .125W F TC=0+-100	24546	C4-1/8-T0-101-F
A21R61	0757-0401	0		RESISTOR 100 1% .125W F TC=0+-100	24546	C4-1/8-T0-101-F
A21R62	0757-0279	0		RESISTOR 3.16K 1% .125W F TC=0+-100	24546	C4-1/8-T0-3161-F
A21R63	0757-0420	3	1	RESISTOR 750 1% .125W F TC=0+-100	24546	C4-1/8-T0-751-F
A21R64	0757-0346	2		RESISTOR 10 1% .125W F TC=0+-100	24546	C4-1/8-T0-10R0-F
A21R65	0757-0277	8		RESISTOR 49.9 1% .125W F TC=0+-100	24546	C4-1/8-T0-4992-F
A21R66	0757-0346	2		RESISTOR 10 1% .125W F TC=0+-100	24546	C4-1/8-T0-10R0-F
A21R67	0698-3444	1		RESISTOR 316 1% .125W F TC=0+-100	24546	C4-1/8-T0-316R-F
A21R68	0757-0277	8		RESISTOR 49.9 1% .125W F TC=0+-100	24546	C4-1/8-T0-4992-F
A21R69	0757-0346	2		RESISTOR 10 1% .125W F TC=0+-100	24546	C4-1/8-T0-10R0-F
A21R70	0757-0401	0		RESISTOR 100 1% .125W F TC=0+-100	24546	C4-1/8-T0-101-F
A21R71	0757-0346	2		RESISTOR 10 1% .125W F TC=0+-100	24546	C4-1/8-T0-10R0-F
A21R72	0757-0401	0		RESISTOR 100 1% .125W F TC=0+-100	24546	C4-1/8-T0-101-F
A21R73	0757-0346	2		RESISTOR 10 1% .125W F TC=0+-100	24546	C4-1/8-T0-10R0-F
A21R74				NOT ASSIGNED		
A21R75	0698-3132	4	8	RESISTOR 261 1% .125W F TC=0+-100	24546	C4-1/8-T0-2610-F
A21R76	0698-3429	2	4	RESISTOR 19.6 1% .125W F TC=0+-100	03888	PME55-1/8-T0-19R6-F
A21R77	0698-3132	4		RESISTOR 261 1% .125W F TC=0+-100	24546	C4-1/8-T0-2610-F

See introduction to this section for ordering information.
 * Indicates factory selected value.

Table 6-3. Replaceable Parts (continued)

Reference Designator	HP Part Number	C D	Qty.	Description	Mfr Code	Mfr Part Number
A21R78	0757-0401	0		RESISTOR 100 1% .125W F TC=0+-100	24546	C4-1/8-T0-101-F
A21R79	0757-0401	0		RESISTOR 100 1% .125W F TC=0+-100	24546	C4-1/8-T0-101-F
A21R80	0757-0346	2		RESISTOR 10 1% .125W F TC=0+-100	24546	C4-1/8-T0-10R0-F
A21R81	0757-0401	0		RESISTOR 100 1% .125W F TC=0+-100	24546	C4-1/8-T0-101-F
A21R82	0757-0401	0		RESISTOR 100 1% .125W F TC=0+-100	24546	C4-1/8-T0-101-F
A21R83	0757-0401	0		RESISTOR 100 1% .125W F TC=0+-100	24546	C4-1/8-T0-101-F
A21R84	0698-3438	3	2	RESISTOR 147 1% .125W F TC=0+-100	24546	C4-1/8-T0-147R-F
A21R85	0698-3132	4		RESISTOR 261 1% .125W F TC=0+-100	24546	C4-1/8-T0-2610-F
A21R86	0698-3429	2		RESISTOR 19.6 1% .125W F TC=0+-100	03888	PME55-1/8-T0-19R6-F
A21R87	0698-3132	4		RESISTOR 261 1% .125W F TC=0+-100	24546	C4-1/8-T0-2610-F
A21R88	0698-3132	4		RESISTOR 261 1% .125W F TC=0+-100	24546	C4-1/8-T0-2610-F
A21R89	0698-3429	2		RESISTOR 19.6 1% .125W F TC=0+-100	03888	PME55-1/8-T0-19R6-F
A21R90	0698-3132	4		RESISTOR 261 1% .125W F TC=0+-100	24546	C4-1/8-T0-2610-F
A21R91	0698-3132	4		RESISTOR 261 1% .125W F TC=0+-100	24546	C4-1/8-T0-2610-F
A21R92	0698-3429	2		RESISTOR 19.6 1% .125W F TC=0+-100	03888	PME55-1/8-T0-19R6-F
A21R93	0698-3132	4		RESISTOR 261 1% .125W F TC=0+-100	24546	C4-1/8-T0-2610-F
A21R94	0757-0277	8		RESISTOR 49.9 1% .125W F TC=0+-100	24546	C4-1/8-T0-4992-F
A21R95	0698-0082	7		RESISTOR 464 1% .125W F TC=0+-100	24546	C4-1/8-T0-4640-F
A21R96	0698-4037	0		RESISTOR 46.4 1% .125W F TC=0+-100	24546	C4-1/8-T0-46R4-F
A21R97	0757-0442	9		RESISTOR 10K 1% .125W F TC=0+-100	24546	C4-1/8-T0-1002-F
A21R98	0757-0199	3		RESISTOR 21.5K 1% .125W F TC=0+-100	24546	C4-1/8-T0-2152-F
A21R99	0698-3430	5		RESISTOR 21.5 1% .125W F TC=0+-100	03888	PME55-1/8-T0-21R5-F
A21R100	0757-0346	2		RESISTOR 10 1% .125W F TC=0+-100	24546	C4-1/8-T0-10R0-F
A21R101	0698-4037	0		RESISTOR 46.4 1% .125W F TC=0+-100	24546	C4-1/8-T0-46R4-F
A21R102	0698-3430	5		RESISTOR 21.5 1% .125W F TC=0+-100	03888	PME55-1/8-T0-21R5-F
A21R103	0757-0400	9	1	RESISTOR 90.9 1% .125W F TC=0+-100	24546	C4-1/8-T0-90R9-F
A21R104	0698-0083	8		RESISTOR 1.96K 1% .125W F TC=0+-100	24546	C4-1/8-T0-1961-F
A21R105	0698-3430	5		RESISTOR 21.5 1% .125W F TC=0+-100	03888	PME55-1/8-T0-21R5-F
A21R106	0757-0440	7	2	RESISTOR 7.5K 1% .125W F TC=0+-100	24546	C4-1/8-T0-7501-F
A21R107	0698-3155	1	1	RESISTOR 4.64K 1% .125W F TC=0+-100	24546	C4-1/8-T0-4641-F
A21R108	0757-0424	7	1	RESISTOR 1.1K 1% .125W F TC=0+-100	24546	C4-1/8-T0-1101-F
A21R109	0757-0440	7		RESISTOR 7.5K 1% .125W F TC=0+-100	24546	C4-1/8-T0-7501-F
A21R110	0698-3430	5		RESISTOR 21.5 1% .125W F TC=0+-100	03888	PME55-1/8-T0-21R5-F
A21R111	0757-0274	5		RESISTOR 1.21K 1% .125W F TC=0+-100	24546	C4-1/8-T0-1211-F
A21R112	0757-0274	5		RESISTOR 1.21K 1% .125W F TC=0+-100	24546	C4-1/8-T0-1211-F
A21R113	0698-0082	7		RESISTOR 464 1% .125W F TC=0+-100	24546	C4-1/8-T0-4640-F
A21R114	0757-0442	9		RESISTOR 10K 1% .125W F TC=0+-100	24546	C4-1/8-T0-1002-F
A21R115	0698-0084	9		RESISTOR 2.15K 1% .125W F TC=0+-100	24546	C4-1/8-T0-2151-F
A21R116	2100-3091	1		RESISTOR-TRMR 2K 10% C TOP-ADJ 17-TRN	32997	3292W-1-202
A21R117	0698-3154	0		RESISTOR 4.22K 1% .125W F TC=0+-100	24546	C4-1/8-T0-
A21R118	0698-3154	0		RESISTOR 4.22K 1% .125W F TC=0+-100	24546	C4-1/8-T0-
A21R119	0698-8827	4	1	RESISTOR 1M 1% .125W F TC=0+-100	24546	C4-1/8-T0-
A21R120	0757-0421	4		RESISTOR 825 1% .125W F TC=0+-100	24546	C4-1/8-T0-
A21R121	0757-0442	9		RESISTOR 10K 1% .125W F TC=0+-100	24546	C4-1/8-T0-1002-F
A21R122	0757-0442	9		RESISTOR 10K 1% .125W F TC=0+-100	24546	C4-1/8-T0-1002-F
A21R123	0698-8827	4		RESISTOR 1M 1% .125W F TC=0+-100	28480	0698-8827
A21R124	0698-8827	4		RESISTOR 1M 1% .125W F TC=0+-100	28480	0698-8827
A21R125	0757-0442	9		RESISTOR 10K 1% .125W F TC=0+-100	24546	C4-1/8-T0-1002-F

See introduction to this section for ordering information.
 * Indicates factory selected value.

Table 6-3. Replaceable Parts (continued)

Reference Designator	HP Part Number	C D	Qty.	Description	Mfr Code	Mfr Part Number
A21R126	0757-0442	9		RESISTOR 10K 1% .125W F TC=0+-100	24546	C4-1/8-T0-1002-F
A21R127	0757-0442	9		RESISTOR 10K 1% .125W F TC=0+-100	24546	C4-1/8-T0-1002-F
A21R128	0757-0442	9		RESISTOR 10K 1% .125W F TC=0+-100	24546	C4-1/8-T0-1002-F
A21R129	0698-8827	4		RESISTOR 1M 1% .125W F TC=0+-100	28480	0698-8827
A21R130	0698-8827	4		RESISTOR 1M 1% .125W F TC=0+-100	28480	0698-8827
A21R131	0757-0459	8		RESISTOR 56.2K 1% .125W F TC=0+-100	24546	C4-1/8-T0-5622-F
A21R132	0757-0441	8		RESISTOR 8.25K 1% .125W F TC=0+-100	24546	C4-1/8-T0-8251-F
A21R133	0698-8827	4		RESISTOR 1M 1% .125W F TC=0+-100	28480	0698-8827
A21R134	0698-8827	4		RESISTOR 1M 1% .125W F TC=0+-100	28480	0698-8827
A21R135	0698-8827	4		RESISTOR 1M 1% .125W F TC=0+-100	28480	0698-8827
A21R136	0698-8827	4		RESISTOR 1M 1% .125W F TC=0+-100	28480	0698-8827
A21R137	0757-0442	9		RESISTOR 10K 1% .125W F TC=0+-100	24546	C4-1/8-T0-1002-F
A21R138	0757-0442	9		RESISTOR 10K 1% .125W F TC=0+-100	24546	C4-1/8-T0-1002-F
A21R139	0757-0442	9		RESISTOR 10K 1% .125W F TC=0+-100	24546	C4-1/8-T0-1002-F
A21R140	0757-0442	9		RESISTOR 10K 1% .125W F TC=0+-100	24546	C4-1/8-T0-1002-F
A21R141	0757-0442	9		RESISTOR 10K 1% .125W F TC=0+-100	24546	C4-1/8-T0-1002-F
A21R142	0757-0442	9		RESISTOR 10K 1% .125W F TC=0+-100	24546	C4-1/8-T0-1002-F
A21R143	0757-0199	3		RESISTOR 21.5K 1% .125W F TC=0+-100	24546	C4-1/8-T0-2152-F
A21R144	0757-0199	3		RESISTOR 21.5K 1% .125W F TC=0+-100	24546	C4-1/8-T0-2152-F
A21R145	0698-3438	3		RESISTOR 147 1% .125W F TC=0+-100	24546	C4-1/8-T0-147R-F
A21R146	0757-0421	3		RESISTOR 825 1% .125W F TC=+-100	28546	C4-1/8-T0-825R-F
A21T1	9100-0823	8	1	TRANSFORMER(TDK113B1) 1:1:1	28480	9100-0823
A21T2	9100-4452	7	1	PULSE TRANSFORMER 112C1	28480	9100-4452
A21TP1	0360-0535	0	10	TERMINAL TEST POINT PCB	00000	ORDER BY DESCRIPT.
A21TP2	0360-0535	0		TERMINAL TEST POINT PCB	00000	ORDER BY DESCRIPT.
A21TP3	0360-0535	0		TERMINAL TEST POINT PCB	00000	ORDER BY DESCRIPT.
A21TP4	0360-0535	0		TERMINAL TEST POINT PCB	00000	ORDER BY DESCRIPT.
A21TP5	0360-0535	0		TERMINAL TEST POINT PCB	00000	ORDER BY DESCRIPT.
A21TP6	0360-0535	0		TERMINAL TEST POINT PCB	00000	ORDER BY DESCRIPT.
A21TP7	0360-0535	0		TERMINAL TEST POINT PCB	00000	ORDER BY DESCRIPT.
A21TP8	0360-0535	0		TERMINAL TEST POINT PCB	00000	ORDER BY DESCRIPT.
A21TP9	0360-0535	0		TERMINAL TEST POINT PCB	00000	ORDER BY DESCRIPT.
A21TP10	0360-0535	0		TERMINAL TEST POINT PCB	00000	ORDER BY DESCRIPT.
A21U1	1820-1730	6	1	IC FF TTL LS D-TYPE POS-EDGE-TRIG COM	01295	SN74LS273N
A21U2	1820-1433	6	1	IC SHF-RGTR TTL LS R-S SERIAL-IN PRL-OUT	01295	SN74LS164N
A21U3	1820-1199	1	1	IC INV TTL LS HEX 1-INP	01295	SN74LS04N
A21U4	1820-1112	8	2	IC FF TTL LS D-TYPE POS-EDGE-TRIG	01295	SN74LS74AN
A21U5	1820-1112	8		IC FF TTL LS D-TYPE POS-EDGE-TRIG	01295	SN74LS74AN
A21U6	1820-1144	6	1	IC GATE TTL LS NOR QUAD 2-INP	01295	SN74LS02N
A21U7	1820-1202	7	2	IC GATE TTL LS NAND TPL 3-INP	01295	SN74LS10N
A21U8	1820-1202	7		IC GATE TTL LS NAND TPL 3-INP	01295	SN74LS10N
A21U9	1826-0065	0	1	IC COMPARATOR PRCN 8-DIP-P PKG	S0545	UPC311C
A21U10	1826-0783	9	2	IC OP AMP LOW-NOISE 8-DIP-C PKG	52063	XR5534ACN
A21U11	1826-0138	8	1	IC COMPARATOR GP QUAD 14-DIP-P PKG	01295	LM339N
A21U12	1826-0412	1	2	IC COMPARATOR PRCN DUAL 8-DIP-P PKG	27014	LM393N
A21U13	1826-0081	0	1	IC OP AMP WB TO-99 PKG	27014	LM318H
A21U14	1826-0783	9		IC OP AMP LOW-NOISE 8-DIP-C PKG	52063	XR5534ACN
A21U15	1820-0430	1	1	IC 309 V RGLTR TO-3	07263	LM309K
A21U16	1826-0147	9	3	IC 7812 V RGLTR TO-220	04713	MC7812CP

See introduction to this section for ordering information.
 * Indicates factory selected value.

Table 6-3. Replaceable Parts (continued)

Reference Designator	HP Part Number	C D	Qty.	Description	Mfr Code	Mfr Part Number
A21U17	1826-0221	0	4	IC V RGLTR TO-220	04713	MC7912CT
A21U18	1826-1316	6	1	IC OP AMP LOW-NOISE 8-DIP-C PKG	28480	1826-1316
A21U19	1826-0412	1		IC COMPARATOR PRCN DUAL 8-DIP-P PKG	27014	LM393N
A21U20	1826-0147	9		IC 7812 V RGLTR TO-220	04713	MC7812CP
A21U21	1826-0221	0		IC V RGLTR TO-220	04713	MC7912CT
A21U22	1826-0221	0		IC V RGLTR TO-220	04713	MC7912CT
A21U23	1826-0147	9		IC 7812 V RGLTR TO-220	04713	MC7812CP
A21U24	1826-0221	0		IC V RGLTR TO-220	04713	MC7912CT
A21U25	04194-81801	6	2	HIC MPX G-P	28480	04194-81801
A21U26	04194-81801	6		HIC MPX G-P	28480	04194-81801
A21W1	1258-0141			JUMPER-REM	28480	1258-0141
A21W2	1258-0141			JUMPER-REM	28480	1258-0141
A21W3	1258-0141			JUMPER-REM	28480	1258-0141
A21W4	04194-61691	0	1	CABLE ASSY	28480	04194-61691
A21W5	04194-61692	1	1	CABLE ASSY	28480	04194-61692

See introduction to this section for ordering information.
 * Indicates factory selected value.

Table 6-3. Replaceable Parts (continued)

Reference Designator	HP Part Number	C D	Qty.	Description	Mfr Code	Mfr Part Number
A21A1	04194-66551	1	1	TEST CHANNEL AMPLIFIER BOARD ASSEMBLY FOR OPTION 350 UNITS	28480	04194-66551
A21A1C1	0121-0060	0	2	CAPACITOR-V TRMR-CER 2-8PF 350V PC-MTG	52763	304322 2/8PF NPO
A21A1C2	0121-0060	0		CAPACITOR-V TRMR-CER 2-8PF 350V PC-MTG	52763	304322 2/8PF NPO
A21A1C3	0180-1085	5	5	CAPACITOR-FXD 4.7UF 16VDC TA	28480	0180-1085
A21A1C4	0180-1085	5		CAPACITOR-FXD 4.7UF 16VDC TA	28480	0180-1085
A21A1C5	0160-4832	4	3	CAPACITOR-FXD .01UF +-10% 100VDC CER	28480	0160-4832
A21A1C6	0180-3363	6	4	CAPACITOR-FXD 22UF +-20% 25VDC AL	28480	0180-3363
A21A1C7	0180-3363	6		CAPACITOR-FXD 22UF +-20% 25VDC AL	28480	0180-3363
A21A1C8	0160-4833	5	1	CAPACITOR-FXD .022UF +-10% 100VDC CER	28480	0160-4833
A21A1C9	0180-1085	5		CAPACITOR-FXD 4.7UF 16VDC TA	28480	0180-1085
A21A1C10	0160-6423	3	2	CAPACITOR 0.047UF 5%	28480	0160-6423
A21A1C11	0180-1746	5	1	CAPACITOR-FXD 15UF +-10% 20VDC TA	56289	150D156X9020B2
A21A1C12	0160-4832	4		CAPACITOR-FXD .01UF +-10% 100VDC CER	28480	0160-4832
A21A1C13	0160-4810	8	2	CAPACITOR-FXD 330PF +-5% 100VDC CER	28480	0160-4810
A21A1C14	0180-3469	3	4	CAPACITOR-FXD 100UF +-20% 25VDC AL	28480	0180-3469
A21A1C15	0160-4795	8	2	CAPACITOR-FXD 4.7PF +- .5PF 100VDC CER	28480	0160-4795
A21A1C16	0180-1085	5		CAPACITOR-FXD 4.7UF 16VDC TA	28480	0180-1085
A21A1C17	0160-4810	8		CAPACITOR-FXD 330PF +-5% 100VDC CER	28480	0160-4810
A21A1C18	0180-3469	3		CAPACITOR-FXD 100UF +-20% 25VDC AL	28480	0180-3469
A21A1C19	0180-3469	3		CAPACITOR FXD 100UF +-20% 25VDC AL	28480	0180-3469
A21A1C20	0160-4795	8		CAPACITOR-FXD 4.7PF +- .5PF 100VDC CER	28480	0160-4795
A21A1C21	0160-4832	4		CAPACITOR-FXD .01UF +-10% 100VDC CER	28480	0160-4832
A21A1C22	0160-4832	4		CAPACITOR-FXD .01UF +-10% 100VDC CER	28480	0160-4832
A21A1C23	0180-3469	3		CAPACITOR-FXD 100UF +-20% 25VDC AL	28480	0180-3469
A21A1C24	0180-0229	7		CAPACITOR-FXD 33UF TA	28480	0180-0229
A21A1C25	0180-3363	6		CAPACITOR-FXD 22UF +-20% 25VDC AL	28480	0180-3363
A21A1C26	0160-3363	6		CAPACITOR-FXD 22UF +-20% 25VDC AL	28480	0160-3363
A21A1C27	0160-4832	4		CAPACITOR-FXD .01UF +-10% 100VDC	28480	0160-4832
A21A1C28	0160-4799	2	4	CAPACITOR-FXD 2.2PF +- .25PF 100VDC CER	28480	0160-4799
A21A1C29	0180-3469	3		CAPACITOR-FXD 100UF +-20% 25VDC AL	28480	0180-3469
A21A1C30				NOT ASSIGNED		
A21A1C31	0160-4832	4		CAPACITOR-FXD .01UF +-10% 100VDC CER	28480	0160-4832
A21A1C32	0160-4832	4		CAPACITOR-FXD .01UF +-10% 100VDC CER	28480	0160-4832
A21A1C33	0160-4789	0	1	CAPACITOR-FXD 15PF +-5% 100VDC CER 0+-30	28480	0160-4789
A21A1C34	0160-4799	2		CAPACITOR-FXD 2.2PF +- .25PF 100VDC CER	28480	0160-4799
A21A1C35	0160-4832	4		CAPACITOR-FXD .01UF +-10% 100VDC CER	28480	0160-4832
A21A1C36	0160-4799	2		CAPACITOR-FXD 2.2PF +- .25PF 100VDC CER	28480	0160-4799
A21A1C37	0160-4799	2		CAPACITOR-FXD 2.2PF +- .25PF 100VDC CER	28480	0160-4799
A21A1C38	0160-4801	7	2	CAPACITOR-FXD 100PF +-5% 100VDC CER	28480	0160-4801
A21A1C39	0160-4801	7		CAPACITOR-FXD 100PF +-5% 100VDC CER	28480	0160-4801
A21A1C40	0160-4832	4		CAPACITOR-FXD .01UF +-10% 100VDC CER	28480	0160-4832
A21A1C41	0160-4832	4		CAPACITOR-FXD .01UF +-10% 100VDC CER	28480	0160-4832
A21A1C42	0180-1085	5		CAPACITOR-FXD 4.7UF 16VDC TA	28480	0180-1085
A21A1C43	0160-6423	3		CAPACITOR 0.047UF 5%	28480	0160-6423
A21A1C44	0160-4832	4		CAPACITOR-FXD .01UF +-10% 100VDC CER	28480	0160-4832
A21A1C45	0160-4832	4		CAPACITOR-FXD .01UF +-10% 100VDC CER	28480	0160-4832
A21A1C46	0160-4832	4		CAPACITOR-FXD .01UF +-10% 100VDC CER	28480	0160-4832

See introduction to this section for ordering information.
* Indicates factory selected value.

Table 6-3. Replaceable Parts (continued)

Reference Designator	HP Part Number	C D	Qty.	Description	Mfr Code	Mfr Part Number
A21A1CR1	1901-0050	3	8	DIODE-SWITCHING 80V 200MA 2NS DO-35	28480	1901-0050
A21A1CR2	1901-0050	3		DIODE-SWITCHING 80V 200MA 2NS DO-35	28480	1901-0050
A21A1CR3	1901-0050	3		DIODE-SWITCHING 80V 200MA 2NS DO-35	28480	1901-0050
A21A1CR4	1901-0050	3		DIODE-SWITCHING 80V 200MA 2NS DO-35	28480	1901-0050
A21A1CR5	1901-0050	3		DIODE-SWITCHING 80V 200MA 2NS DO-35	28480	1901-0050
A21A1CR6	1901-0050	3		DIODE-SWITCHING 80V 200MA 2NS DO-35	28480	1901-0050
A21A1CR7	1901-0050	3		DIODE-SWITCHING 80V 200MA 2NS DO-35	28480	1901-0050
A21A1CR8	1901-0050	3		DIODE-SWITCHING 80V 200MA 2NS DO-35	28480	1901-0050
A21A1J1	1250-1810	4	2	CONNECTOR-RF SMB M PC-OHM	28480	1250-1810
A21A1J2	1250-1810	4		CONNECTOR-RF SMB M PC-OHM	28480	1250-1810
A21A1J3	1251-4683	7	8	CONNECTOR-SGL CONT SKT .04-IN-BSC-SZ RND	28480	1251-4683
A21A1J4	1251-4683	7		CONNECTOR-SGL CONT SKT .04-IN-BSC-SZ RND	28480	1251-4683
A21A1J5	1251-4683	7		CONNECTOR-SGL CONT SKT .04-IN-BSC-SZ RND	28480	1251-4683
A21A1J6	1251-4683	7		CONNECTOR-SGL CONT SKT .04-IN-BSC-SZ RND	28480	1251-4683
A21A1J7	1251-4683	7		CONNECTOR-SGL CONT SKT .04-IN-BSC-SZ RND	28480	1251-4683
A21A1J8	1251-4683	7		CONNECTOR-SGL CONT SKT .04-IN-BSC-SZ RND	28480	1251-4683
A21A1J9	1251-4683	7		CONNECTOR-SGL CONT SKT .04-IN-BSC-SZ RND	28480	1251-4683
A21A1J10	1251-4683	7		CONNECTOR-SGL CONT SKT .04-IN-BSC-SZ RND	28480	1251-4683
A21A1J11	1200-0796	8	1	SOCKET-IC 8-CONT DIP DIP-SLDR	28480	1200-0796
A21A1K1	0490-1485	6	3	RELAY SW	28480	0490-1485
A21A1K2	0490-1485	6		RELAY SW	28480	0490-1485
A21A1K3	0490-1485	6		RELAY SW	28480	0490-1485
A21A1K4	0490-1486	7	2	RELAY-REED	28480	0490-1486
A21A1K5	0490-1486	7		RELAY-REED	28480	0490-1486
A21A1L1	9170-0029	3	6	CORE-SHIELDING BEAD	28480	9170-0029
A21A1L2	9170-0029	3		CORE-SHIELDING BEAD	28480	9170-0029
A21A1L3	9100-2259	8	3	INDUCTOR RF-CH-MLD 1.5UH 10% .105DX.26LG	28480	9100-2259
A21A1L4	9100-2259	8		INDUCTOR RF-CH-MLD 1.5UH 10% .105DX.26LG	28480	9100-2259
A21A1L5	9100-2259	8		INDUCTOR RF-CH-MLD 1.5UH 10% .105DX.26LG	28480	9100-2259
A21A1L6	9170-0029	3		CORE-SHIELDING BEAD	28480	9170-0029
A21A1L7	9170-0029	3		CORE-SHIELDING BEAD	28480	9170-0029
A21A1L8	9170-0029	3		CORE-SHIELDING BEAD	28480	9170-0029
A21A1L9	9170-0029	3		CORE-SHIELDING BEAD	28480	9170-0029
A21A1Q1	1854-1073	1	3	TRANSISTOR NPN SI PD=600MW FT=6.5GHZ	28480	1854-1073
A21A1Q2	1854-1073	1		TRANSISTOR NPN SI PD=600MW FT=6.5GHZ	28480	1854-1073
A21A1Q3	1854-1073	1		TRANSISTOR NPN SI PD=600MW FT=6.5GHZ	28480	1854-1073
A21A1Q4	1855-0081	1	1	TRANSISTOR J-FET N-CHAN D-MODE SI	28480	1855-0081
A21A1R1	0757-0442	9	3	RESISTOR 10K 1% .125W F TC=0+-100	24546	C4-1/8-T0-1002-F
A21A1R2	0757-0442	9		RESISTOR 10K 1% .125W F TC=0+-100	24546	C4-1/8-T0-1002-F
A21A1R3	0757-0442	9		RESISTOR 10K 1% .125W F TC=0+-100	24546	C4-1/8-T0-1002-F
A21A1R4	0698-3430	5	4	RESISTOR 21.5 1% .125W F TC=0+-100	03888	PME55-1/8-T0-21R5-F
A21A1R5	0698-4037	0	1	RESISTOR 46.4 1% .125W F TC=0+-100	24546	C4-1/8-T0-46R4-F
A21A1R6	0698-0084	9	2	RESISTOR 2.15K 1% .125W F TC=0+-100	24546	C4-1/8-T0-2151-F
A21A1R7	0757-0280	3	2	RESISTOR 1K 1% .125W F TC=0+-100	24546	C4-1/8-T0-1001-F
A21A1R8	0757-0277	8	6	RESISTOR 49.9 1% .125W F TC=0+-100	24546	C4-1/8-T0-4992-F
A21A1R9	0757-0279	0	3	RESISTOR 3.16K 1% .125W F TC=0+-100	24546	C4-1/8-T0-3161-F
A21A1R10	0698-3155	1	2	RESISTOR 4.64K 1% .125W F TC=0+-100	24546	C4-1/8-T0-4641-F
A21A1R11	0757-0440	7	3	RESISTOR 7.5K 1% .125W F TC=0+-100	24546	C4-1/8-T0-7501-F
A21A1R12	0757-0421	4	2	RESISTOR 825 1% .125W F TC=0+-100	24546	C4-1/8-T0-825R-F

See introduction to this section for ordering information.
 * Indicates factory selected value.

Table 6-3. Replaceable Parts (continued)

Reference Designator	HP Part Number	C D	Qty.	Description	Mfr Code	Mfr Part Number
A21A1R13	0757-0279	0		RESISTOR 3.16K 1% .125W F TC=0+-100	24546	C4-1/8-T0-3161-F
A21A1R14	0757-0440	7		RESISTOR 7.5K 1% .125W F TC=0+-100	24546	C4-1/8-T0-7501-F
A21A1R15	0757-0402	1	1	RESISTOR 110 1% .125W F TC=0+-100	24546	C4-1/8-T0-111-F
A21A1R16	0757-0280	3		RESISTOR 1K 1% .125W F TC=0+-100	24546	C4-1/8-T0-1001-F
A21A1R17	0698-3444	1	1	RESISTOR 316 1% .125W F TC=0+-100	24546	C4-1/8-T0-316R-F
A21A1R18	0757-0180	2	1	RESISTOR 31.6 1% .125W F TC=0+-100	28480	0757-0180
A21A1R19	0698-3438	3	2	RESISTOR 147 1% .125W F TC=0+-100	24546	C4-1/8-T0-147R-F
A21A1R20	0757-0277	8		RESISTOR 49.9 1% .125W F TC=0+-100	24546	C4-1/8-T0-4992-F
A21A1R21	0757-0277	8		RESISTOR 49.9 1% .125W F TC=0+-100	24546	C4-1/8-T0-4992-F
A21A1R22	0698-3155	1		RESISTOR 4.64K 1% .125W F TC=0+-100	24546	C4-1/8-T0-4641-F
A21A1R23	0757-0440	7		RESISTOR 7.5K 1% .125W F TC=0+-100	24546	C4-1/8-T0-7501-G
A21A1R24	0757-0277	8		RESISTOR 49.9 1% .125W F TC=0+-100	24546	C4-1/8-T0-4992-F
A21A1R25	0757-0277	8		RESISTOR 49.9 1% .125W F TC=0+-100	24546	C4-1/8-T0-4992-F
A21A1R26	0757-0438	3	3	RESISTOR 5.11K 1% .125W F TC=0+-100	24546	C4-1/8-T0-5111-F
A21A1R27	0698-3430	5		RESISTOR 21.5 1% .125W F TC=0+-100	03888	PME55-1/8-T0-21R5-F
A21A1R28	0698-3155	1		RESISTOR 4.64K 1% .125W F TC=0+-100	24546	C4-1/8-T0-4641-F
A21A1R29	0757-0440	7		RESISTOR 7.5K 1% .125W F TC=0+-100	24546	C4-1/8-T0-7501-F
A21A1R30	2100-3091	1	1	RESISTOR-TRMR 2K 10% C TOP-ADJ 17-TRN	32997	3292W-1-202
A21A1R31	0698-3154	0	2	RESISTOR 4.22K 1% .125W F TC=0+-100	24546	C4-1/8-T0-4221-F
A21A1R32	0698-3154	0		RESISTOR 4.22K 1% .125W F TC=0+-100	24546	C4-1/8-T0-4221-F
A21A1R33	0757-0397	3	1	RESISTOR 68.1 1% .125W F TC=0+-100	24546	C4-1/8-T0-68R1-F
A21A1R34	0698-3438	3		RESISTOR 147 1% .125W F TC=0+-100	24546	C4-1/8-T0-147R-F
A21A1R35	0698-3430	5		RESISTOR 21.5 1% .125W F TC=0+-100	03888	PME55-1/8-T0-21R5-F
A21A1R36	0757-0417	8	1	RESISTOR 562		
A21A1R37	0698-0084	9		RESISTOR 2.15K 1% .125W F TC=0+-100	24546	C4-1/8-T0-2151-F
A21A1R38	0698-3430	5		RESISTOR 21.5 1% .125W F TC=0+-100	03888	PME55-1/8-T0-21R5-F
A21A1R39	0757-0280	3		RESISTOR 1.0K		
A21A1R40	0699-1811	4		RESISTOR 50.5 0.1% .125W TC=+-50		RN14C2B50.5B
A21A1R41	0757-0421	4		RESISTOR 825 1% .125W F TC=0+-100	24546	C4-1/8-T0-825R-F
A21A1R42	0699-1703	3	2	RESISTOR 61.11 .1% .125W F TC=0+-50	28480	0699-1703
A21A1R43	0698-3159	5	1	RESISTOR 26.1K 1% .125W F TC=0+-100	24546	C4-1/8-T0-2612-F
A21A1R44	0698-3160	8	1	RESISTOR 31.6K 1% .125W F TC=0+-100	24546	C4-1/8-T0-3162-F
A21A1R45	0757-0441	8	1	RESISTOR 8.25K 1% .125W F TC=0+-100	24546	C4-1/8-T0-8251-F
A21A1R46	0757-0466	7	1	RESISTOR 110K 1% .125W F TC=0+-100	24546	C4-1/8-T0-1103-F
A21A1R47	0757-0379	1	2	RESISTOR 12.1 1% .125W F TC=0+-100	19701	MF4C1/8-T0-12R1-F
A21A1R48	0698-8827	4	1	RESISTOR 1M 1% .125W F TC=0+-100	28480	0698-8827
A21A1R49	0699-1813	6	2	RESISTOR 292.4 0.1%		RN14C2B292.4B
A21A1R50	0699-1812	5	1	RESISTOR 17.61 0.1% .125W TC=+-50		RN14C217.61B
A21A1R51	0699-1813	6		RESISTOR 292.4 0.1%		RN14C2B292.4B
A21A1R52	0699-1703	3		RESISTOR 61.11 .1% .125W F TC=0+-50	28480	0699-1703
A21A1R53	0699-1671	4	1	RESISTOR 247.5 .1% .125W F TC=0+-50	28480	0699-1671
A21A1R54	0757-0467	8	2	RESISTOR 121K 1% .125W F TC=0+-100	24546	C4-1/8-T0-1213-F
A21A1R55	0698-8961	7	1	RESISTOR 909K 1% .125W F TC=0+-100	28480	0698-8961
A21A1R56	0757-0199	3	1	RESISTOR 21.5K 1% .125W F TC=0+-100	24546	C4-1/8-T0-2152-F
A21A1R57	0698-3152	3		RESISTOR 3.48K 1% .125W F TC=0+-100	24546	C4-1/8-T0-3481-F
A21A1R58	0698-3152	3		RESISTOR 3.48K 1% .125W F TC=0+-100	24546	C4-1/8-T0-3481-F
A21A1R59	0757-0467	8		RESISTOR 121K 1% .125W F TC=0+-100	24546	C4-1/8-T0-1213-F
A21A1R60	0757-0379	1		RESISTOR 12.1 1% .125W F TC=0+-100	19701	MF4C1/8-T0-12R1-F
A21A1R61	0683-2255	9	2	RESISTOR 2.2M 5% .25W FC TC=-900/+1100	01121	CB2255

See introduction to this section for ordering information.
 * Indicates factory selected value.

Table 6-3. Replaceable Parts (continued)

Reference Designator	HP Part Number	C D	Qty.	Description	Mfr Code	Mfr Part Number
A21A1R62	0698-3459	8	2	RESISTOR 383K 1% .125W F TC=0+-100	28480	0698-3459
A21A1R63	0683-2255	9		RESISTOR 2.2M 5% .25W FC TC=-900/+1100	01121	CB2255
A21A1R64	0698-3459	8		RESISTOR 383K 1% .125W F TC=0+-100	28480	0698-3459
A21A1R65	0698-0085	0		RESISTOR 2.61K		
A21A1TP1	0360-0535	0	1	TERMINAL TEST POINT PCB	00000	ORDER BY DESCRIPT.
A21A1U1	1858-0047	5	1	TRANSISTOR ARRAY 16-PIN PLSTC DIP	13606	ULN-2003A
A21A1U2	1826-1317	7	1	IC OP AMP LOW-NOISE 8-DIP-P PKG	28480	1826-1317
A21A1U3	1826-0521	3	1	IC OP AMP LOW-BIAS-H-IMPD DUAL 8-DIP-P	01295	TL072CP

See introduction to this section for ordering information.
 * Indicates factory selected value.

Table 6-3. Replaceable Parts (continued)

Reference Designator	HP Part Number	C D	Qty.	Description	Mfr Code	Mfr Part Number
A21A2	04194-66552	2	1	REFERENCE CHANNEL AMPLIFIER BOARD ASSEMBLY FOR OPTION 350 UNITS	28480	04194-66552
A21A2C1	0121-0060	0	2	CAPACITOR-V TRMR-CER 2-8PF 350V PC-MTG	52763	304322 2/8PF NPO
A21A2C2	0121-0060	0		CAPACITOR-V TRMR-CER 2-8PF 350V PC-MTG	52763	304322 2/8PF NPO
A21A2C3	0160-4832	4	3	CAPACITOR-FXD .01UF +-10% 100VDC CER	28480	0160-4832
A21A2C4	0160-4810	8	2	CAPACITOR-FXD 330PF +-5% 100VDC CER	28480	0160-4810
A21A2C5	0180-1746	5	1	CAPACITOR-FXD 15UF +-10% 20VDC TA	56289	150D156X9020B2
A21A2C6	0160-6423	3	2	CAPACITOR 0.047UF 5%	28480	0160-6423
A21A2C7	0180-1085	5	5	CAPACITOR-FXD 4.7UF 16VDC TA	28480	0180-1085
A21A2C8	0180-1085	5		CAPACITOR-FXD 4.7UF 16VDC TA	28480	0180-1085
A21A2C9	0160-4833	5	1	CAPACITOR-FXD .022UF +-10% 100VDC CER	28480	0160-4833
A21A2C10	0180-3363	6	4	CAPACITOR-FXD 22UF +-20% 25VDC AL	28480	0180-3363
A21A2C11	0180-3363	6		CAPACITOR-FXD 22UF +-20% 25VDC AL	28480	0180-3363
A21A2C12	0160-4832	4		CAPACITOR-FXD .01UF +-10% 100VDC CER	28480	0160-4832
A21A2C13	0180-1085	5		CAPACITOR-FXD 4.7UF 16VDC TA	28480	0180-1085
A21A2C14	0160-4832	4		CAPACITOR-FXD .01UF +-10% 100VDC CER	28480	0160-4832
A21A2C15	0160-4810	8		CAPACITOR-FXD 330PF +-5% 100VDC CER	28480	0160-4810
A21A2C16	0180-1085	5		CAPACITOR-FXD 4.7UF 16VDC TA	28480	0180-1085
A21A2C17	0160-4795	8	2	CAPACITOR-FXD 4.7PF +- .5PF 100VDC CER	28480	0160-4795
A21A2C18	0160-4832	4		CAPACITOR-FXD .01UF +-10% 100VDC CER	28480	0160-4832
A21A2C19	0160-4795	8		CAPACITOR-FXD 4.7PF +- .5PF 100VDC CER	28480	0160-4795
A21A2C20	0180-3469	3	4	CAPACITOR-FXD 100UF +-20% 25VDC AL	28480	0180-3469
A21A2C21				NOT ASSIGNED		
A21A2C22	0180-3469	3		CAPACITOR-FXD 100UF +-20% 25VDC AL	28480	0180-3469
A21A2C23	0160-4832	4		CAPACITOR-FXD .01UF +-10% 100VDC CER	28480	0160-4832
A21A2C24	0180-3469	3		CAPACITOR-FXD 100UF +-20% 25VDC AL	28480	0180-3469
A21A2C25	0160-4799	2	4	CAPACITOR-FXD 2.2PF +- .25PF 100VDC CER	28480	0160-4799
A21A2C26	0160-4832	4		CAPACITOR-FXD .01UF +-10% 100VDC CER	28480	0160-4832
A21A2C27	0180-3363	6		CAPACITOR-FXD 22UF +-20% 25VDC AL	28480	0180-3363
A21A2C28	0180-3363	6		CAPACITOR-FXD 22UF +-20% 25VDC AL	28480	0180-3363
A21A2C29	0180-0229	7		CAPACITOR-FXD 33UF +-20% 25VDC AL	28480	0180-0229
A21A2C30	0180-3469	3		CAPACITOR-FXD 100UF +-20% 25VDC AL	28480	0180-3469
A21A2C31	0180-3469	3		CAPACITOR-FXD 100UF +-20% 25VDC AL	28480	0180-3469
A21A2C32	0160-4801	7	2	CAPACITOR-FXD 100PF +-5% 100VDC CER	28480	0160-4801
A21A2C33	0160-4801	7		CAPACITOR-FXD 100PF +-5% 100VDC CER	28480	0160-4801
A21A2C34	0160-4832	4		CAPACITOR-FXD .01UF +-10% 100VDC CER	28480	0160-4832
A21A2C35	0160-4799	2		CAPACITOR-FXD 2.2PF +- .25PF 100VDC CER	28480	0160-4799
A21A2C36	0160-4799	2		CAPACITOR-FXD 2.2PF +- .25PF 100VDC CER	28480	0160-4799
A21A2C37	0160-4832	4		CAPACITOR-FXD .01UF +-10% 100VDC CER	28480	0160-4832
A21A2C38	0160-4789	0	1	CAPACITOR-FXD 15PF +-5% 100VDC CER 0+-30	28480	0160-4789
A21A2C39	0160-4832	4		CAPACITOR-FXD .01UF +-10% 100VDC CER	28480	0160-4832
A21A2C40	0160-4832	4		CAPACITOR-FXD .01UF +-10% 100VDC CER	28480	0160-4832
A21A2C41	0160-4832	4		CAPACITOR-FXD .01UF +-10% 100VDC CER	28480	0160-4832
A21A2C42	0160-4832	4		CAPACITOR-FXD .01UF +-10% 100VDC CER	28480	0160-4832
A21A2C43	0180-1085	5		CAPACITOR-FXD 4.7UF 16VDC TA	28480	0180-1085
A21A2C44	0160-6423	3		CAPACITOR 0.047UF 5%	28480	0160-6423
A21A2C45	0160-4832	4		CAPACITOR-FXD .01UF +-10% 100VDC CER	28480	0160-4832
A21A2C46	0160-4799	2		CAPACITOR-FXD 2.2PF +- .25PF 100VDC CER	28480	0160-4799

See introduction to this section for ordering information.
 * Indicates factory selected value.

Table 6-3. Replaceable Parts (continued)

Reference Designator	HP Part Number	C D	Qty.	Description	Mfr Code	Mfr Part Number
A21A2CR1	1901-0050	3	8	DIODE-SWITCHING 80V 200MA 2NS DO-35	28480	1901-0050
A21A2CR2	1901-0050	3		DIODE-SWITCHING 80V 200MA 2NS DO-35	28480	1901-0050
A21A2CR3	1901-0050	3		DIODE-SWITCHING 80V 200MA 2NS DO-35	28480	1901-0050
A21A2CR4	1901-0050	3		DIODE-SWITCHING 80V 200MA 2NS DO-35	28480	1901-0050
A21A2CR5	1901-0050	3		DIODE-SWITCHING 80V 200MA 2NS DO-35	28480	1901-0050
A21A2CR6	1901-0050	3		DIODE-SWITCHING 80V 200MA 2NS DO-35	28480	1901-0050
A21A2CR7	1901-0050	3		DIODE-SWITCHING 80V 200MA 2NS DO-35	28480	1901-0050
A21A2CR8	1901-0050	3		DIODE-SWITCHING 80V 200MA 2NS DO-35	28480	1901-0050
A21A2J1	1250-1810	4	2	CONNECTOR-RF SMB M PC-OHM	28480	1250-1810
A21A2J2	1250-1810	4		CONNECTOR-RF SMB M PC-OHM	28480	1250-1810
A21A2J3	1251-4683	7	8	CONNECTOR-SGL CONT SKT .04-IN-BSC-SZ RND	28480	1251-4683
A21A2J4	1251-4683	7		CONNECTOR-SGL CONT SKT .04-IN-BSC-SZ RND	28480	1251-4683
A21A2J5	1251-4683	7		CONNECTOR-SGL CONT SKT .04-IN-BSC-SZ RND	28480	1251-4683
A21A2J6	1251-4683	7		CONNECTOR-SGL CONT SKT .04-IN-BSC-SZ RND	28480	1251-4683
A21A2J7	1251-4683	7		CONNECTOR-SGL CONT SKT .04-IN-BSC-SZ RND	28480	1251-4683
A21A2J8	1251-4683	7		CONNECTOR-SGL CONT SKT .04-IN-BSC-SZ RND	28480	1251-4683
A21A2J9	1251-4683	7		CONNECTOR-SGL CONT SKT .04-IN-BSC-SZ RND	28480	1251-4683
A21A2J10	1251-4683	7		CONNECTOR-SGL CONT SKT .04-IN-BSC-SZ RND	28480	1251-4683
A21A2J11	1200-0796	8	1	SOCKET-IC 8-CONT DIP DIP-SLDR	28480	1200-0796
A21A2K1	0490-1485	6	3	RELAY SW	28480	0490-1485
A21A2K2	0490-1485	6		RELAY SW	28480	0490-1485
A21A2K3	0490-1485	6		RELAY SW	28480	0490-1485
A21A2K4	0490-1486	7	2	RELAY-REES	28480	0490-1486
A21A2K5	0490-1486	7		RELAY-REES	28480	0490-1486
A21A2L1	9170-0029	3	6	CORE-SHIELDING BEAD	28480	9170-0029
A21A2L2	9100-2259	8	3	INDUCTOR RF-CH-MLD 1.5UH 10% .105DX.26LG	28480	9100-2259
A21A2L3	9100-2259	8		INDUCTOR RF-CH-MLD 1.5UH 10% .105DX.26LG	28480	9100-2259
A21A2L4	9100-2259	8		INDUCTOR RF-CH-MLD 1.5UH 10% .105DX.26LG	28480	9100-2259
A21A2L5	9170-0029	3		CORE-SHIELDING BEAD	28480	9170-0029
A21A2L6	9170-0029	3		CORE-SHIELDING BEAD	28480	9170-0029
A21A2L7	9170-0029	3		CORE-SHIELDING BEAD	28480	9170-0029
A21A2L8	9170-0029	3		CORE-SHIELDING BEAD	28480	9170-0029
A21A2L9	9170-0029	3		CORE-SHIELDING BEAD	28480	9170-0029
A21A2Q1	1854-1073	1	3	TRANSISTOR NPN SI PD=600MW FT=6.5GHZ	28480	1854-1073
A21A2Q2	1854-1073	1		TRANSISTOR NPN SI PD=600MW FT=6.5GHZ	28480	1854-1073
A21A2Q3	1854-1073	1		TRANSISTOR NPN SI PD=600MW FT=6.5GHZ	28480	1854-1073
A21A2Q4	1855-0081	1	1	TRANSISTOR J-FET N-CHAN D-MODE SI	28480	1855-0081
A21A2R1	0757-0277	8	6	RESISTOR 49.9 1% .125W F TC=0+-100	24546	C4-1/8-T0-4992-F
A21A2R2	0757-0280	3	2	RESISTOR 1K 1% .125W F TC=0+-100	24546	C4-1/8-T0-1001-F
A21A2R3	0698-0084	9	2	RESISTOR 2.15K 1% .125W F TC=0+-100	24546	C4-1/8-T0-2151-F
A21A2R4	0698-4037	0	1	RESISTOR 46.4 1% .125W F TC=0+-100	24546	C4-1/8-T0-46R4-F
A21A2R5	0698-3430	5	4	RESISTOR 21.5 1% .125W F TC=0+-100	03888	PME55-1/8-T0-21R5-F
A21A2R6	0757-0442	9	3	RESISTOR 10K 1% .125W F TC=0+-100	24546	C4-1/8-T0-1002-F
A21A2R7	0757-0442	9		RESISTOR 10K 1% .125W F TC=0+-100	24546	C4-1/8-T0-1002-F
A21A2R8	0757-0442	9		RESISTOR 10K 1% .125W F TC=0+-100	24546	C4-1/8-T0-1002-F
A21A2R9	0757-0280	3		RESISTOR 1K 1% .125W F TC=0+-100	24546	C4-1/8-T0-1001-F
A21A2R10	0698-3444	1	1	RESISTOR 316 1% .125W F TC=0+-100	24546	C4-1/8-T0-316R-F
A21A2R11	0757-0402	1	1	RESISTOR 110 1% .125W F TC=0+-100	24546	C4-1/8-T0-111-F

See introduction to this section for ordering information.
 * Indicates factory selected value.

Table 6-3. Replaceable Parts (continued)

Reference Designator	HP Part Number	C D	Qty.	Description	Mfr Code	Mfr Part Number
A21A2R12	0757-0440	7	3	RESISTOR 7.5K 1% .125W F TC=0+-100	24546	C4-1/8-T0-7501-F
A21A2R13	0757-0279	0	3	RESISTOR 3.16K 1% .125W F TC=0+-100	24546	C4-1/8-T0-3161-F
A21A2R14	0757-0421	4	2	RESISTOR 825 1% .125W F TC=0+-100	24546	C4-1/8-T0-825R-F
A21A2R15	0757-0440	7		RESISTOR 7.5K 1% .125W F TC=0+-100	24546	C4-1/8-T0-7501-F
A21A2R16	0698-3155	1	2	RESISTOR 4.64K 1% .125W F TC=0+-100	24546	C4-1/8-T0-4641-F
A21A2R17	0757-0279	0		RESISTOR 3.16K 1% .125W F TC=0+-100	24546	C4-1/8-T0-3161-F
A21A2R18	0698-3159	5	1	RESISTOR 26.1K 1% .125W F TC=0+-100	24546	C4-1/8-T0-2612-F
A21A2R19	0698-3154	0	2	RESISTOR 4.22K 1% .125W F TC=0+-100	24546	C4-1/8-T0-4221-F
A21A2R20	0698-3154	0		RESISTOR 4.22K 1% .125W F TC=0+-100	24546	C4-1/8-T0-4221-F
A21A2R21	2100-3091	1	1	RESISTOR-TRMR 2K 10% C TOP-ADJ 17-TRN	32997	3292W-1-202
A21A2R22	0757-0440	7		RESISTOR 7.5K 1% .125W F TC=0+-100	24546	C4-1/8-T0-7501-F
A21A2R23	0698-3155	1		RESISTOR 4.64K 1% .125W F TC=0+-100	24546	C4-1/8-T0-4641-F
A21A2R24	0757-0277	8		RESISTOR 49.9 1% .125W F TC=0+-100	24546	C4-1/8-T0-4992-F
A21A2R25	0757-0277	8		RESISTOR 49.9 1% .125W F TC=0+-100	24546	C4-1/8-T0-4992-F
A21A2R26	0698-3430	5		RESISTOR 21.5 1% .125W F TC=0+-100	03888	PME55-1/8-T0-21R5-F
A21A2R27	0757-0438	3	3	RESISTOR 5.11K 1% .125W F TC=0+-100	24546	C4-1/8-T0-5111-F
A21A2R28	0757-0277	8		RESISTOR 49.9 1% .125W F TC=0+-100	24546	C4-1/8-T0-4992-F
A21A2R29	0757-0277	8		RESISTOR 49.9 1% .125W F TC=0+-100	24546	C4-1/8-T0-4992-F
A21A2R30	0698-0085	0		RESISTOR 2.61K		
A21A2R31	0757-0440	7		RESISTOR 7.50K		
A21A2R32	0698-3155	1		RESISTOR 4.64K 1% .125W F TC=0+-100	24546	C4-1/8-T0-4641-F
A21A2R33	0698-3438	3	2	RESISTOR 147 1% .125W F TC=0+-100	24546	C4-1/8-T0-147R-F
A21A2R34	0757-0180	2	1	RESISTOR 31.6 1% .125W F TC=0+-100	28480	0757-0180
A21A2R35	0757-0467	8	2	RESISTOR 121K 1% .125W F TC=0+-100	24546	C4-1/8-T0-1213-F
A21A2R36	0698-3152	3		RESISTOR 3.48K 1% .125W F TC=0+-100	24546	C4-1/8-T0-3481-F
A21A2R37	0698-3160	8	1	RESISTOR 31.6K 1% .125W F TC=0+-100	24546	C4-1/8-T0-3162-F
A21A2R38	0757-0441	8	1	RESISTOR 8.25K 1% .125W F TC=0+-100	24546	C4-1/8-T0-8251-F
A21A2R39	0699-1671	4	1	RESISTOR 247.5 .1% .125W F TC=0+-50	28480	0699-1671
A21A2R40	0699-1703	3	2	RESISTOR 61.11 .1% .125W F TC=0+-50	28480	0699-1703
A21A2R41	0757-0421	4		RESISTOR 825 1% .125W F TC=0+-100	24546	C4-1/8-T0-825R-F
A21A2R42	0699-1811	4		RESISTOR 50.50 0.1% .125W F TC=0+-50	24546	RN14C2B50.5B
A21A2R43	0698-3430	5		RESISTOR 21.5 1% .125W F TC=0+-100	03888	PME55-1/8-T0-21R5-F
A21A2R44	0698-0084	9		RESISTOR 2.15K 1% .125W F TC=0+-100	24546	C4-1/8-T0-2151-F
A21A2R45	0698-3430	5		RESISTOR 21.5 1% .125W F TC=0+-100	03888	PME55-1/8-T0-21R5-F
A21A2R46	0757-0417	8		RESISTOR 562		
A21A2R47	0698-3438	3		RESISTOR 147 1% .125W F TC=0+-100	24546	C4-1/8-T0-147R-F
A21A2R48	0757-0397	3	1	RESISTOR 68.1 1% .125W F TC=0+-100	24546	C4-1/8-T0-68R1-F
A21A2R49	0698-3152	3		RESISTOR 3.48K 1% .125W F TC=0+-100	24546	C4-1/8-T0-3481-F
A21A2R50	0757-0467	8		RESISTOR 121K 1% .125W F TC=0+-100	24546	C4-1/8-T0-1213-F
A21A2R51	0757-0199	3	1	RESISTOR 21.5K 1% .125W F TC=0+-100	24546	C4-1/8-T0-2152-F
A21A2R52	0699-1703	3		RESISTOR 61.11 .1% .125W F TC=0+-50	28480	0699-1703
A21A2R53	0699-1813	6	2	RESISTOR 292.4 0.1%	24546	RN14C2B292.4B
A21A2R54	0699-1812	5	1	RESISTOR 17.61 0.1% .125W F TC=0+-50	03888	RN14C2B17.61B
A21A2R55	0699-1813	6		RESISTOR 292.4 0.1%	24546	RN14C2B292.4B
A21A2R56	0698-8827	4	1	RESISTOR 1M 1% .125W F TC=0+-100	28480	0698-8827
A21A2R57	0757-0379	1	2	RESISTOR 12.1 1% .125W F TC=0+-100	19701	MF4C1/8-T0-12R1-F
A21A2R58	0757-0466	7	1	RESISTOR 110K 1% .125W F TC=0+-100	24546	C4-1/8-T0-1103-F
A21A2R59	0698-8961	7	1	RESISTOR 909K 1% .125W F TC=0+-100	28480	0698-8961
A21A2R60	0698-3459	8	2	RESISTOR 383K 1% .125W F TC=0+-100	28480	0698-3459

See introduction to this section for ordering information.
* Indicates factory selected value.

Table 6-3. Replaceable Parts (continued)

Reference Designator	HP Part Number	C D	Qty.	Description	Mfr Code	Mfr Part Number
A21A2R61	0683-2255	9	2	RESISTOR 2.2M 5% .25W FC TC=-900/+1100	01121	CB2255
A21A2R62	0698-3459	8		RESISTOR 383K 1% .125W F TC=0+-100	28480	0698-3459
A21A2R63	0683-2255	9		RESISTOR 2.2M 5% .25W FC TC=-900/+1100	01121	CB2255
A21A2R64	0757-0379	1		RESISTOR 12.1 1% .125W F TC=0+-100	19701	MF4C1/8-T0-12R1-F
A21A2R65	0757-0280	3		RESISTOR 1.0K		
A21A2TP1	0360-0535	0	1	TERMINAL TEST POINT PCB	00000	ORDER BY DESCRIPTION
A21A2U1	1858-0047	5	1	TRANSISTOR ARRAY 16-PIN PLSTC DIP	13606	ULN-2003A
A21A2U2	1826-1317	7	1	IC OP AMP LOW-NOISE 8-DIP-P PKG	28480	1826-1317
A21A2U3	1826-0521	3	1	IC OP AMP LOW-BIAS-H-IMPED DUAL 8-DIP-P	01295	TL072CP

See introduction to this section for ordering information.
 * Indicates factory selected value.

Table 6-3. Replaceable Parts (continued)

Reference Designator	HP Part Number	C D	Qty.	Description	Mfr Code	Mfr Part Number
A22	04194-66522	6	1	MODULATOR/FREQUENCY CONVERTER BOARD ASSEMBLY	28480	04194-66522
A22C1	0160-4832	4	26	CAPACITOR-FXD .01UF +-10% 100VDC CER	28480	0160-4832
A22C2	0160-4822	2	32	CAPACITOR-FXD 1000PF +-5% 100VDC CER	28480	0160-4822
A22C3				NOT ASSIGNED		
A22C4	0160-4822	2		CAPACITOR-FXD 1000PF +-5% 100VDC CER	28480	0160-4822
A22C5	0160-4832	4		CAPACITOR-FXD .01UF +-10% 100VDC CER	28480	0160-4832
A22C6	0160-4832	4		CAPACITOR-FXD .01UF +-10% 100VDC CER	28480	0160-4832
A22C7	0160-4822	2		CAPACITOR-FXD 1000PF +-5% 100VDC CER	28480	0160-4822
A22C8	0160-4822	2		CAPACITOR-FXD 1000PF +-5% 100VDC CER	28480	0160-4822
A22C9	0160-4822	2		CAPACITOR-FXD 1000PF +-5% 100VDC CER	28480	0160-4822
A22C10	0160-4822	2		CAPACITOR-FXD 1000PF +-5% 100VDC CER	28480	0160-4822
A22C11	0160-4805	1	4	CAPACITOR-FXD 47PF +-5% 100VDC CER 0+-30	28480	0160-4805
A22C12	0160-4804	0	2	CAPACITOR-FXD 56PF +-5% 100VDC CER 0+-30	28480	0160-4804
A22C13	0160-4803	9	2	CAPACITOR-FXD 68PF +-5% 100VDC CER 0+-30	28480	0160-4803
A22C14	0160-4786	7	4	CAPACITOR-FXD 27PF +-5% 100VDC CER 0+-30	28480	0160-4786
A22C15	0160-4814	2	2	CAPACITOR-FXD 150PF +-5% 100VDC CER	28480	0160-4814
A22C16	0160-4832	4		CAPACITOR-FXD .01UF +-10% 100VDC CER	28480	0160-4832
A22C17	0160-4801	7	2	CAPACITOR-FXD 100PF +-5% 100VDC CER	28480	0160-4801
A22C18	0160-4814	2		CAPACITOR-FXD 150PF +-5% 100VDC CER	28480	0160-4814
A22C19	0160-4803	9		CAPACITOR-FXD 68PF +-5% 100VDC CER 0+-30	28480	0160-4803
A22C20	0160-4801	7		CAPACITOR-FXD 100PF +-5% 100VDC CER	28480	0160-4801
A22C21	0160-4835	7	6	CAPACITOR-FXD .1UF +-10% 50VDC CER	28480	0160-4835
A22C22	0180-3469	3	9	CAPACITOR-FXD 100UF +-20% 25VDC AL	28480	0180-3469
A22C23	0180-3469	3		CAPACITOR-FXD 100UF +-20% 25VDC AL	28480	0180-3469
A22C24	0160-4835	7		CAPACITOR-FXD .1UF +-10% 50VDC CER	28480	0160-4835
A22C25	0180-3469	3		CAPACITOR-FXD 100UF +-20% 25VDC AL	28480	0180-3469
A22C26	0180-3469	3		CAPACITOR-FXD 100UF +-20% 25VDC AL	28480	0180-3469
A22C27	0160-4835	7		CAPACITOR-FXD .1UF +-10% 50VDC CER	28480	0160-4835
A22C28	0160-4832	4		CAPACITOR-FXD .01UF +-10% 100VDC CER	28480	0160-4832
A22C29	0160-4832	4		CAPACITOR-FXD .01UF +-10% 100VDC CER	28480	0160-4832
A22C30	0160-4822	2		CAPACITOR-FXD 1000PF +-5% 100VDC CER	28480	0160-4822
A22C31	0160-4822	2		CAPACITOR-FXD 1000PF +-5% 100VDC CER	28480	0160-4822
A22C32	0160-4832	4		CAPACITOR-FXD .01UF +-10% 100VDC CER	28480	0160-4832
A22C33	0160-4832	4		CAPACITOR-FXD .01UF +-10% 100VDC CER	28480	0160-4832
A22C34	0160-4822	2		CAPACITOR-FXD 1000PF +-5% 100VDC CER	28480	0160-4822
A22C35	0160-4822	2		CAPACITOR-FXD 1000PF +-5% 100VDC CER	28480	0160-4822
A22C36	0160-4822	2		CAPACITOR-FXD 1000PF +-5% 100VDC CER	28480	0160-4822
A22C37	0160-4832	4		CAPACITOR-FXD .01UF +-10% 100VDC CER	28480	0160-4832
A22C38	0160-4832	4		CAPACITOR-FXD .01UF +-10% 100VDC CER	28480	0160-4832
A22C39	0160-4822	2		CAPACITOR-FXD 1000PF +-5% 100VDC CER	28480	0160-4822
A22C40	0160-4805	1		CAPACITOR-FXD 47PF +-5% 100VDC CER 0+-30	28480	0160-4805
A22C41	0160-4787	8	4	CAPACITOR-FXD 22PF +-5% 100VDC CER 0+-30	28480	0160-4787
A22C42	0160-4835	7		CAPACITOR-FXD .1UF +-10% 50VDC CER	28480	0160-4835
A22C43	0160-4833		1	CAPACITOR-FXD 0.022UF 10%	28480	0160-4833
A22C44	0160-4822	2		CAPACITOR-FXD 1000PF +-5% 100VDC CER	28480	0160-4822
A22C45	0180-3469	3		CAPACITOR-FXD 100UF +-20% 25VDC AL	28480	0180-3469
A22C46	0180-3593	4	1	CAPACITOR-FXD 330UF +-20% 25VDC AL	28480	0180-3593

See introduction to this section for ordering information.
 * Indicates factory selected value.

Table 6-3. Replaceable Parts (continued)

Reference Designator	HP Part Number	C D	Qty.	Description	Mfr Code	Mfr Part Number
A22C47	0121-0060	0	1	CAPACITOR-V TRMR-CER 2-8PF 350V PC-MTG	52763	304322 2/8PF NPO
A22C48	0180-3469	3		CAPACITOR-FXD 100UF +-20% 25VDC AL	28480	0180-3469
A22C49	0160-4822	2		CAPACITOR-FXD 1000PF +-5% 100VDC CER	28480	0160-4822
A22C50	0160-0127	2	2	CAPACITOR-FXD 1UF +-20% 25VDC CER	28480	0160-0127
A22C51	0160-4832	4		CAPACITOR-FXD .01UF +-10% 100VDC CER	28480	0160-4832
A22C52	0160-4832	4		CAPACITOR-FXD .01UF +-10% 100VDC CER	28480	0160-4832
A22C53	0180-1085	5	14	CAPACITOR-FXD 4.7UF 16VDC TA	28480	0180-1085
A22C54	0180-1085	5		CAPACITOR-FXD 4.7UF 16VDC TA	28480	0180-1085
A22C55	0180-1085	5		CAPACITOR-FXD 4.7UF 16VDC TA	28480	0180-1085
A22C56	0180-1085	5		CAPACITOR-FXD 4.7UF 16VDC TA	28480	0180-1085
A22C57	0160-4832	2		CAPACITOR-FXD 0.01UF 10%	28480	0160-4832
A22C58	0160-4832	2		CAPACITOR-FXD 0.01UF 10%	28480	0160-4832
A22C59	0180-3469	3		CAPACITOR-FXD 100UF +-20% 25VDC AL	28480	0180-3469
A22C60	0180-3469	3		CAPACITOR-FXD 100UF +-20% 25VDC AL	28480	0180-3469
A22C61	0160-4822	2		CAPACITOR-FXD 1000PF +-5% 100VDC CER	28480	0160-4822
A22C62	0160-4822			CAPACITOR-FXD 1000PF 5%	28480	0160-4822
A22C63				NOT ASSIGNED		
A22C64	0160-4822	2		CAPACITOR-FXD 1000PF +-5% 100VDC CER	28480	0160-4822
A22C65	0160-4822	2		CAPACITOR-FXD 1000PF +-5% 100VDC CER	28480	0160-4822
A22C66	0160-4822	2		CAPACITOR-FXD 1000PF +-5% 100VDC CER	28480	0160-4822
A22C67	0160-4832	4		CAPACITOR-FXD .01UF +-10% 100VDC CER	28480	0160-4832
A22C68	0160-4832	4		CAPACITOR-FXD .01UF +-10% 100VDC CER	28480	0160-4832
A22C69	0160-4822	2		CAPACITOR-FXD 1000PF +-5% 100VDC CER	28480	0160-4822
A22C70	0160-4822	2		CAPACITOR-FXD 1000PF +-5% 100VDC CER	28480	0160-4822
A22C71	0160-4788	9	2	CAPACITOR-FXD 18PF +-5% 100VDC CER 0+-30	28480	0160-4788
A22C72	0160-4807	3	2	CAPACITOR-FXD 33PF +-5% 100VDC CER 0+-30	28480	0160-4807
A22C73	0160-4788	9		CAPACITOR-FXD 18PF +-5% 100VDC CER 0+-30	28480	0160-4788
A22C74	0160-6345	8	2	CAPACITOR 3.3UF	28480	0160-6345
A22C75	0160-6343	6	2	CAPACITOR 0.33U	28480	0160-6343
A22C76	0160-6345	8		CAPACITOR 3.3UF	28480	0160-6345
A22C77	0160-6343	6		CAPACITOR 0.33U	28480	0160-6343
A22C78	0160-3901	6	2	CAPACITOR-FXD 2.2UF +-20% 25VDC CER	28480	0160-3901
A22C79	0160-3901	6		CAPACITOR-FXD 2.2UF +-20% 25VDC CER	28480	0160-3901
A22C80	0160-4787	8		CAPACITOR-FXD 22PF +-5% 100VDC CER 0+-30	28480	0160-4787
A22C81	0160-4805	1		CAPACITOR-FXD 47PF +-5% 100VDC CER 0+-30	28480	0160-4805
A22C82	0160-4804	0		CAPACITOR-FXD 56PF +-5% 100VDC CER 0+-30	28480	0160-4804
A22C83	0160-4805	1		CAPACITOR-FXD 47PF +-5% 100VDC CER 0+-30	28480	0160-4805
A22C84	0160-4786	7		CAPACITOR-FXD 27PF +-5% 100VDC CER 0+-30	28480	0160-4786
A22C85	0160-4835	7		CAPACITOR-FXD .1UF +-10% 50VDC CER	28480	0160-4835
A22C86	0180-3469	3		CAPACITOR-FXD 100UF +-20% 25VDC AL	28480	0180-3469
A22C87	0160-4835	7		CAPACITOR-FXD .1UF +-10% 50VDC CER	28480	0160-4835
A22C88	0160-4832	4		CAPACITOR-FXD .01UF +-10% 100VDC CER	28480	0160-4832
A22C89	0180-1085	5		CAPACITOR-FXD 4.7UF 16VDC TA	28480	0180-1085
A22C90	0160-4791	4	2	CAPACITOR-FXD 10PF +-5% 100VDC CER 0+-30	28480	0160-4791
A22C91	0180-1085	5		CAPACITOR-FXD 4.7UF 16VDC TA	28480	0180-1085
A22C92	0180-1085	5		CAPACITOR-FXD 4.7UF 16VDC TA	28480	0180-1085
A22C93	0160-4791	4		CAPACITOR-FXD 10PF +-5% 100VDC CER 0+-30	28480	0160-4791
A22C94	0180-1085	5		CAPACITOR-FXD 4.7UF 16VDC TA	28480	0180-1085

See introduction to this section for ordering information.
* Indicates factory selected value.

Table 6-3. Replaceable Parts (continued)

Reference Designator	HP Part Number	C D	Qty.	Description	Mfr Code	Mfr Part Number
A22C95	0160-4822	2		CAPACITOR-FXD 1000PF +-5% 100VDC CER	28480	0160-4822
A22C96	0160-4822	2		CAPACITOR-FXD 1000PF +-5% 100VDC CER	28480	0160-4822
A22C97	0160-4789	0	3	CAPACITOR-FXD 15PF +-5% 100VDC CER 0+-30	28480	0160-4789
A22C98	0160-4786	7		CAPACITOR-FXD 27PF +-5% 100VDC CER 0+-30	28480	0160-4786
A22C99	0160-4786	7		CAPACITOR-FXD 27PF +-5% 100VDC CER 0+-30	28480	0160-4786
A22C100	0160-4789	0		CAPACITOR-FXD 15PF +-5% 100VDC CER 0+-30	28480	0160-4789
A22C101	0160-3878	6	2	CAPACITOR-FXD 1000PF +-20% 100VDC CER	28480	0160-3878
A22C102	0160-2234	6	1	CAPACITOR-FXD .51PF +- .25PF 500VDC CER	28480	0160-2234
A22C103	0160-4822	2		CAPACITOR-FXD 1000PF +-5% 100VDC CER	28480	0160-4822
A22C104	0180-3363	6	3	CAPACITOR-FXD 22UF +-20% 25VDC AL	28480	0180-3363
A22C105	0180-3363	6		CAPACITOR-FXD 22UF +-20% 25VDC AL	28480	0180-3363
A22C106	0160-4822	2		CAPACITOR-FXD 1000PF +-5% 100VDC CER	28480	0160-4822
A22C107	0160-4822	2		CAPACITOR-FXD 1000PF +-5% 100VDC CER	28480	0160-4822
A22C108	0160-4832	4		CAPACITOR-FXD .01UF +-10% 100VDC CER	28480	0160-4832
A22C109	0160-4822	2		CAPACITOR-FXD 1000PF +-5% 100VDC CER	28480	0160-4822
A22C110	0160-4832	4		CAPACITOR-FXD .01UF +-10% 100VDC CER	28480	0160-4832
A22C111	0160-4832	4		CAPACITOR-FXD .01UF +-10% 100VDC CER	28480	0160-4832
A22C112	0160-4832	4		CAPACITOR-FXD .01UF +-10% 100VDC CER	28480	0160-4832
A22C113				NOT ASSIGNED		
A22C114				NOT ASSIGNED		
A22C115	0180-1085	5		CAPACITOR-FXD 4.7UF 16VDC TA	28480	0180-1085
A22C116	0160-4832	4		CAPACITOR-FXD .01UF +-10% 100VDC CER	28480	0160-4832
A22C117	0180-3363	6		CAPACITOR-FXD 22UF +-20% 25VDC AL	28480	0180-3363
A22C118	0180-3587	6	1	CAPACITOR-FXD 1000UF +-20% 50VDC AL	28480	0180-3587
A22C119	0160-4787	8		CAPACITOR-FXD 22PF +-5% 100VDC CER 0+-30	28480	0160-4787
A22C120	0160-4806	2	2	CAPACITOR-FXD 39PF +-5% 100VDC CER 0+-30	28480	0160-4806
A22C121	0160-4806	2		CAPACITOR-FXD 39PF +-5% 100VDC CER 0+-30	28480	0160-4806
A22C122	0160-4787	8		CAPACITOR-FXD 22PF +-5% 100VDC CER 0+-30	28480	0160-4787
A22C123	0160-4822	2		CAPACITOR-FXD 1000PF +-5% 100VDC CER	28480	0160-4822
A22C124	0160-4822	2		CAPACITOR-FXD 1000PF +-5% 100VDC CER	28480	0160-4822
A22C125	0160-4789	0		CAPACITOR-FXD 15PF +-5% 100VDC CER 0+-30	28480	0160-4789
A22C126	0180-1085	5		CAPACITOR-FXD 4.7UF 16VDC TA	28480	0180-1085
A22C127	0180-1085	5		CAPACITOR-FXD 4.7UF 16VDC TA	28480	0180-1085
A22C128	0160-4822	2		CAPACITOR-FXD 1000PF +-5% 100VDC CER	28480	0160-4822
A22C129	0160-4822	2		CAPACITOR-FXD 1000PF +-5% 100VDC CER	28480	0160-4822
A22C130	0180-1085	5		CAPACITOR-FXD 4.7UF 16VDC TA	28480	0180-1085
A22C131	0180-1085	5		CAPACITOR-FXD 4.7UF 16VDC TA	28480	0180-1085
A22C132	0160-4795	8	1	CAPACITOR-FXD 4.7PF +- .5PF 100VDC CER	28480	0160-4795
A22C133	0180-1085	5		CAPACITOR-FXD 4.7UF 16VDC TA	28480	0180-1085
A22C134	0160-3878	6		CAPACITOR-FXD 1000PF +-20% 100VDC CER	28480	0160-3878
A22C135	0160-4832	4		CAPACITOR-FXD .01UF +-10% 100VDC CER	28480	0160-4832
A22C136	0160-4832	4		CAPACITOR-FXD .01UF +-10% 100VDC CER	28480	0160-4832
A22C137	0160-4822	2		CAPACITOR-FXD 1000PF +-5% 100VDC CER	28480	0160-4822
A22C138	0160-4798	1	1	CAPACITOR-FXD 2.7PF +- .25PF 100VDC CER	28480	0160-4798
A22C139	0160-4832	4		CAPACITOR-FXD .01UF +-10% 100VDC CER	28480	0160-4832
A22C140	0160-4832	4		CAPACITOR-FXD .01UF +-10% 100VDC CER	28480	0160-4832
A22C141	0160-0127	2		CAPACITOR-FXD 1UF +-20% 25VDC CER	28480	0160-0127
A22C142	0160-4807	3		CAPACITOR-FXD 33PF +-5% 100VDC CER 0+-30	28480	0160-4807
A22CR1	1901-0050	3	8	DIODE-SWITCHING 80V 200MA 2NS DO-35	28480	1901-0050

See introduction to this section for ordering information.
 * Indicates factory selected value.

Table 6-3. Replaceable Parts (continued)

Reference Designator	HP Part Number	C D	Qty.	Description	Mfr Code	Mfr Part Number
A22CR2	1901-0050	3		DIODE-SWITCHING 80V 200MA 2NS DO-35	28480	1901-0050
A22CR3	1902-0950	4	1	DIODE-ZNR 4.7V 5% DO-35 PD=.4W TC=+.025%	28480	1902-0950
A22CR4	1902-0948	0	2	DIODE-ZNR 3.9V 5% DO-35 PD=.4W TC=-.012%	28480	1902-0948
A22CR5	1902-0948	0		DIODE-ZNR 3.9V 5% DO-35 PD=.4W TC=-.012%	28480	1902-0948
A22CR6	1902-0953	7	8	DIODE-ZNR 6.2V 5% DO-35 PD=.4W TC=+.057%	28480	1902-0953
A22CR7	1902-0953	7		DIODE-ZNR 6.2V 5% DO-35 PD=.4W TC=+.057%	28480	1902-0953
A22CR8	1902-0953	7		DIODE-ZNR 6.2V 5% DO-35 PD=.4W TC=+.057%	28480	1902-0953
A22CR9	1902-0953	7		DIODE-ZNR 6.2V 5% DO-35 PD=.4W TC=+.057%	28480	1902-0953
A22CR10	1902-0692	1	1	DIODE-ZNR 6.3V 1% DO-7 PD=.4W TC=+.001%	28480	1902-0692
A22CR11	1901-0050	3		DIODE-SWITCHING 80V 200MA 2NS DO-35	28480	1901-0050
A22CR12	1901-0050	3		DIODE-SWITCHING 80V 200MA 2NS DO-35	28480	1901-0050
A22CR13	1902-0954	8		DIODE-ZNR 6.8V 5% DO-35 PD=.4W TC=+.057%	28480	1902-0954
A22CR14	1902-0954	8		DIODE-ZNR 6.8V 5% DO-35 PD=.4W TC=+.057%	28480	1902-0954
A22CR15	1902-0954	8		DIODE-ZNR 6.8V 5% DO-35 PD=.4W TC=+.057%	28480	1902-0954
A22CR16	1902-0954	8		DIODE-ZNR 6.8V 5% DO-35 PD=.4W TC=+.057%	28480	1902-0954
A22CR17	1901-0050	3		DIODE-SWITCHING 80V 200MA 2NS DO-35	28480	1901-0050
A22CR18	1901-0050	3		DIODE-SWITCHING 80V 200MA 2NS DO-35	28480	1901-0050
A22CR19	1901-0050	3		DIODE-SWITCHING 80V 200MA 2NS DO-35	28480	1901-0050
A22CR20	1901-0050	3		DIODE-SWITCHING 80V 200MA 2NS DO-35	28480	1901-0050
A22DS1	1990-0665	3	2	LED-LAMP LUM-INT=1MCD IF=20MA-MAX BVR=5V	28480	1990-0665
A22DS2	1990-0665	3		LED-LAMP LUM-INT=1MCD IF=20MA-MAX BVR=5V	28480	1990-0665
A22DS3	1990-0665	3		LED-LAMP LUM-INT=1MCD IF=20MA-MAX BVR=5V	28480	1990-0665
A22DS4	1990-0665	3		LED-LAMP LUM-INT=1MCD IF=20MA-MAX BVR=5V	28480	1990-0665
A22DS5	1990-0665	3		LED-LAMP LUM-INT=1MCD IF=20MA-MAX BVR=5V	28480	1990-0665
A22DS6	1990-0665	3		LED-LAMP LUM-INT=1MCD IF=20MA-MAX BVR=5V	28480	1990-0665
A22DS7	1990-0665	3		LED-LAMP LUM-INT=1MCD IF=20MA-MAX BVR=5V	28480	1990-0665
A22DS8	1990-0665	3		LED-LAMP LUM-INT=1MCD IF=20MA-MAX BVR=5V	28480	1990-0665
A22DS9	1990-0665	3		LED-LAMP LUM-INT=1MCD IF=20MA-MAX BVR=5V	28480	1990-0665
A22DS10	1990-0665	3		LED-LAMP LUM-INT=1MCD IF=20MA-MAX BVR=5V	28480	1990-0665
A22DS11	1990-0665	3		LED-LAMP LUM-INT=1MCD IF=20MA-MAX BVR=5V	28480	1990-0665
A22DS12	1990-0665	3		LED-LAMP LUM-INT=1MCD IF=20MA-MAX BVR=5V	28480	1990-0665
A22E1	1906-0235	6	3	DIODE SBL-1	28480	SBL-1
A22E2	1906-0235	6		DIODE SBL-1	28480	SBL-1
A22E3	1906-0235	6		DIODE SBL-1	28480	SBL-1
A22F1	2110-0592	2	3	FUSE 4A 125V NTD .281X.093	28480	2110-0592
A22F2	2110-0592	2		FUSE 4A 125V NTD .281X.093	28480	2110-0592
A22F3	2110-0592	2		FUSE 4A 125V NTD .281X.093	28480	2110-0592
A22J1	1250-0257	1	10	CONNECTOR-RF SMB M PC 50-OHM	28480	1250-0257
A22J2	1250-0257	1		CONNECTOR-RF SMB M PC 50-OHM	28480	1250-0257
A22J3	1200-0541	1	3	SOCKET-IC 24-CONT DIP DIP-SLDR	28480	1200-0541
A22J4	1200-0541	1		SOCKET-IC 24-CONT DIP DIP-SLDR	28480	1200-0541
A22J5	1250-0257	1		CONNECTOR-RF SMB M PC 50-OHM	28480	1250-0257
A22J6	1250-0257	1		CONNECTOR-RF SMB M PC 50-OHM	28480	1250-0257
A22J7	1250-0257	1		CONNECTOR-RF SMB M PC 50-OHM	28480	1250-0257
A22J8	1250-0257	1		CONNECTOR-RF SMB M PC 50-OHM	28480	1250-0257
A22J9	1250-0257	1		CONNECTOR-RF SMB M PC 50-OHM	28480	1250-0257
A22J10	1200-0541	1		SOCKET-IC 24-CONT DIP DIP-SLDR	28480	1200-0541
A22J11	1250-0257	1		CONNECTOR-RF SMB M PC 50-OHM	28480	1250-0257
A22J12	1250-0257	1		CONNECTOR-RF SMB M PC 50-OHM	28480	1250-0257

See introduction to this section for ordering information.
* Indicates factory selected value.

Table 6-3. Replaceable Parts (continued)

Reference Designator	HP Part Number	C D	Qty.	Description	Mfr Code	Mfr Part Number
A22J13	1250-0257	1		CONNECTOR-RF SMB M PC 50-OHM	28480	1250-0257
A22J14	1251-3090	8	1	CONNECTOR 50-PIN M RECTANGULAR	28480	1251-3090
A22J15	1251-3004	4	1	CONNECTOR 40-PIN M RECTANGULAR	28480	1251-3004
A22J16	1251-5066	2	1	CONNECTOR 2-PIN M METRIC POST TYPE	28480	1251-5066
A22J17	1251-5339	2	1	CONNECTOR 9-PIN M UTILITY	28480	1251-5339
A22L1	9100-2247	4	20	INDUCTOR RF-CH-MLD 100NH 10% .105DX.26LG	28480	9100-2247
A22L2	9100-2259	8	6	INDUCTOR RF-CH-MLD 1.5UH 10% .105DX.26LG	28480	9100-2259
A22L3	9100-2247	4		INDUCTOR RF-CH-MLD 100NH 10% .105DX.26LG	28480	9100-2247
A22L4	9100-2247	4		INDUCTOR RF-CH-MLD 100NH 10% .105DX.26LG	28480	9100-2247
A22L5	9100-2252	1	3	INDUCTOR RF-CH-MLD 270NH 10% .105DX.26LG	28480	9100-2252
A22L6	9100-2252	1		INDUCTOR RF-CH-MLD 270NH 10% .105DX.26LG	28480	9100-2252
A22L7	9100-2252	1		INDUCTOR RF-CH-MLD 270NH 10% .105DX.26LG	28480	9100-2252
A22L8	9100-2891	4	3	INDUCTOR RF-CH-MLD 50NH 10% .105DX.26LG	28480	9100-2891
A22L9				NOT ASSIGNED		
A22L10	9100-2247	4		INDUCTOR RF-CH-MLD 100NH 10% .105DX.26LG	28480	9100-2247
A22L11	9100-3139	5	2	INDUCTOR 75UH 15% .5DX.675LG	28480	9100-3139
A22L12	9100-1629	4	1	INDUCTOR RF-CH-MLD 47UH	28480	9100-1629
A22L13	9100-3139	5		INDUCTOR 75UH 15% .5DX.875LG	28480	9100-3139
A22L14	9100-2247	4		INDUCTOR RF-CH-MLD 100NH 10% .105DX.26LG	28480	9100-2247
A22L15	9100-2259	8		INDUCTOR RF-CH-MLD 1.5UH 10% .105DX.26LG	28480	9100-2259
A22L16	9100-2247	4		INDUCTOR RF-CH-MLD 100NH 10% .105DX.26LG	28480	9100-2247
A22L17	9100-2247	4		INDUCTOR RF-CH-MLD 100NH 10% .105DX.26LG	28480	9100-2247
A22L18	9100-2247	4		INDUCTOR RF-CH-MLD 100NH 10% .105DX.26LG	28480	9100-2247
A22L19	9100-2259	8		INDUCTOR RF-CH-MLD 1.5UH 10% .105DX.26LG	28480	9100-2259
A22L20	9100-2251	0	3	INDUCTOR RF-CH-MLD 220NH 10% .105DX.26LG	28480	9100-2251
A22L21	9100-2247	4		INDUCTOR RF-CH-MLD 100NH 10% .105DX.26LG	28480	9100-2247
A22L22	9100-2251	0		INDUCTOR RF-CH-MLD 220NH 10% .105DX.26LG	28480	9100-2251
A22L23	9100-2247	4		INDUCTOR RF-CH-MLD 100NH 10% .105DX.26LG	28480	9100-2247
A22L24	9100-2247	4		INDUCTOR RF-CH-MLD 100NH 10% .105DX.26LG	28480	9100-2247
A22L25	9100-2247	4		INDUCTOR RF-CH-MLD 100NH 10% .105DX.26LG	28480	9100-2247
A22L26	9100-2247	4		INDUCTOR RF-CH-MLD 100NH 10% .105DX.26LG	28480	9100-2247
A22L27	9100-2247	4		INDUCTOR RF-CH-MLD 100NH 10% .105DX.26LG	28480	9100-2247
A22L28	9100-2259	8		INDUCTOR RF-CH-MLD 1.5UH 10% .105DX.26LG	28480	9100-2259
A22L29	9100-2247	4		INDUCTOR RF-CH-MLD 100NH 10% .105DX.26LG	28480	9100-2247
A22L30	9100-2247	4		INDUCTOR RF-CH-MLD 100NH 10% .105DX.26LG	28480	9100-2247
A22L31	9100-2247	4		INDUCTOR RF-CH-MLD 100NH 10% .105DX.26LG	28480	9100-2247
A22L32	9100-0368	6	2	INDUCTOR RF-CH-MLD 330NH 10% .105DX.26LG	28480	9100-0368
A22L33	9100-0368	6		INDUCTOR RF-CH-MLD 330NH 10% .105DX.26LG	28480	9100-0368
A22L34	9100-2249	6	2	INDUCTOR RF-CH-MLD 150NH 10% .105DX.26LG	28480	9100-2249
A22L35	9100-2247	4		INDUCTOR RF-CH-MLD 100NH 10% .105DX.26LG	28480	9100-2247
A22L36	9100-2251	0		INDUCTOR RF-CH-MLD 220NH 10% .105DX.26LG	28480	9100-2251
A22L37	9100-2247	4		INDUCTOR RF-CH-MLD 100NH 10% .105DX.26LG	28480	9100-2247
A22L38	9100-2249	6		INDUCTOR RF-CH-MLD 150NH 10% .105DX.26LG	28480	9100-2249
A22L39	9100-2247	4		INDUCTOR RF-CH-MLD 100NH 10% .105DX.26LG	28480	9100-2247
A22L40	9100-2891	4		INDUCTOR RF-CH-MLD 50NH 10% .105DX.26LG	28480	9100-2891
A22L41	9140-0158	6	1	INDUCTOR RF-CH-MLD 1UH 10% .105DX.26LG	28480	9140-0158
A22L42	9100-2891	4		INDUCTOR RF-CH-MLD 50NH 10% .105DX.26LG	28480	9100-2891
A22L43	9100-2259	8		INDUCTOR RF-CH-MLD 1.5UH 10% .105DX.26LG	28480	9100-2259
A22L44	9100-2259	8		INDUCTOR RF-CH-MLD 1.5UH 10% .105DX.26LG	28480	9100-2259

See introduction to this section for ordering information.
 * Indicates factory selected value.

Table 6-3. Replaceable Parts (continued)

Reference Designator	HP Part Number	C D	Qty.	Description	Mfr Code	Mfr Part Number
A22L45	9140-0114	4	1	INDUCTOR RF-CH-MLD 10UH 10% .166DX.385LG	28480	9140-0114
A22Q1	1854-1073	1	12	TRANSISTOR NPN SI PD=600MW FT=6.5GHZ	28480	1854-1073
A22Q2	1854-1073	1		TRANSISTOR NPN SI PD=600MW FT=6.5GHZ	28480	1854-1073
A22Q3	1854-1073	1		TRANSISTOR NPN SI PD=600MW FT=6.5GHZ	28480	1854-1073
A22Q4	1854-1073	1		TRANSISTOR NPN SI PD=600MW FT=6.5GHZ	28480	1854-1073
A22Q5	1854-1073	1		TRANSISTOR NPN SI PD=600MW FT=6.5GHZ	28480	1854-1073
A22Q6	1854-1073	1		TRANSISTOR NPN SI PD=600MW FT=6.5GHZ	28480	1854-1073
A22Q7	1854-0637	1	1	TRANSISTOR NPN 2N2219A SI TO-5 PD=800MW	01295	2N2219A
A22Q8	1854-1073	1		TRANSISTOR NPN SI PD=600MW FT=6.5GHZ	28480	1854-1073
A22Q9	1854-1073	1		TRANSISTOR NPN SI PD=600MW FT=6.5GHZ	28480	1854-1073
A22Q10	1853-0459	3	3	TRANSISTOR PNP SI PD=625MW FT=200MHZ	28480	1853-0459
A22Q11	1853-0459	3		TRANSISTOR PNP SI PD=625MW FT=200MHZ	28480	1853-0459
A22Q12	1854-1073	1		TRANSISTOR NPN SI PD=600MW FT=6.5GHZ	28480	1854-1073
A22Q13	1854-1073	1		TRANSISTOR NPN SI PD=600MW FT=6.5GHZ	28480	1854-1073
A22Q14	1854-1074	2	2	TRANSISTOR NPN SI PD=200MW FT=30MHZ	28480	1854-1074
A22Q15	1854-1074	2		TRANSISTOR NPN SI PD=200MW FT=30MHZ	28480	1854-1074
A22Q16	1854-1073	1		TRANSISTOR NPN SI PD=600MW FT=6.5GHZ	28480	1854-1073
A22Q17	1854-1073	1		TRANSISTOR NPN SI PD=600MW FT=6.5GHZ	28480	1854-1073
A22Q18	1853-0459	3		TRANSISTOR PNP SI PD=625MW FT=200MHZ	28480	1853-0459
A22Q19	1854-0215	1	1	TRANSISTOR NPN SI PD=350MW FT=300MHZ	04713	2N3904
A22R1	0698-4037	0	8	RESISTOR 46.4 1% .125W F TC=0+-100	24546	C4-1/8-T0-46R4-F
A22R2	0757-0382	6	6	RESISTOR 16.2 1% .125W F TC=0+-100	19701	MF4C1/8-T0-16R2-F
A22R3	0757-0180	2	17	RESISTOR 31.6 1% .125W F TC=0+-100	28480	0757-0180
A22R4	0757-0180	2		RESISTOR 31.6 1% .125W F TC=0+-100	28480	0757-0180
A22R5	0698-4037	0		RESISTOR 46.4 1% .125W F TC=0+-100	24546	C4-1/8-T0-46R4-F
A22R6	0757-0397	3	5	RESISTOR 68.1 1% .125W F TC=0+-100	24546	C4-1/8-T0-68R1-F
A22R7	0698-0083	8	5	RESISTOR 1.96K 1% .125W F TC=0+-100	24546	C4-1/8-T0-1961-F
A22R8	0757-0401	0	14	RESISTOR 100 1% .125W F TC=0+-100	24546	C4-1/8-T0-101-F
A22R9				NOT ASSIGNED		
A22R10	0757-0418	9	4	RESISTOR 619 1% .125W F TC=0+-100	24546	C4-1/8-T0-619R-F
A22R11	0698-4425	0	3	RESISTOR 1.54K 1% .125W F TC=0+-100	24546	C4-1/8-T0-1541-F
A22R12	0698-4444	3	3	RESISTOR 4.87K 1% .125W F TC=0+-100	24546	C4-1/8-T0-4871-F
A22R13	0757-0417	8	3	RESISTOR 562 1% .125W F TC=0+-100	24546	C4-1/8-T0-562R-F
A22R14	0757-0401	0		RESISTOR 100 1% .125W F TC=0+-100	24546	C4-1/8-T0-101-F
A22R15	0757-0294	9	12	RESISTOR 17.8 1% .125W F TC=0+-100	19701	MF4C1/8-T0-17R8-F
A22R16	0757-0294	9		RESISTOR 17.8 1% .125W F TC=0+-100	19701	MF4C1/8-T0-17R8-F
A22R17	0698-3443	0	8	RESISTOR 287 1% .125W F TC=0+-100	24546	C4-1/8-T0-287R-F
A22R18	0757-0294	9		RESISTOR 17.8 1% .125W F TC=0+-100	19701	MF4C1/8-T0-17R8-F
A22R19	0698-3443	0		RESISTOR 287 1% .125W F TC=0+-100	24546	C4-1/8-T0-287R-F
A22R20	0698-0082	7	6	RESISTOR 464 1% .125W F TC=0+-100	24546	C4-1/8-T0-4640-F
A22R21	0757-0379	1	2	RESISTOR 12.1 1% .125W F TC=0+-100	19701	MF4C1/8-T0-12R1-F
A22R22	0698-0082	7		RESISTOR 464 1% .125W F TC=0+-100	24546	C4-1/8-T0-4640-F
A22R23	0757-0180	2		RESISTOR 31.6 1% .125W F TC=0+-100	28480	0757-0180
A22R24	0757-0395	1	3	RESISTOR 56.2 1% .125W F TC=0+-100	24546	C4-1/8-T0-56R2-F
A22R25	0757-0180	2		RESISTOR 31.6 1% .125W F TC=0+-100	28480	0757-0180
A22R26	0757-0346	2	4	RESISTOR 10 1% .125W F TC=0+-100	24546	C4-1/8-T0-10R0-F
A22R27	0757-0401	0		RESISTOR 100 1% .125W F TC=0+-100	24546	C4-1/8-T0-101-F
A22R28	2100-3212	5	3	RESISTOR-TRMR 200 10% C 1-TRN	28480	2100-3212
A22R29	0757-0401	0		RESISTOR 100 1% .125W F TC=0+-100	24546	C4-1/8-T0-101-F

See introduction to this section for ordering information.
 * Indicates factory selected value.

Table 6-3. Replaceable Parts (continued)

Reference Designator	HP Part Number	C D	Qty.	Description	Mfr Code	Mfr Part Number
A22R30	0698-4037	0		RESISTOR 46.4 1% .125W F TC=0+-100	24546	C4-1/8-T0-46R4-F
A22R31	0757-0280	3	6	RESISTOR 1K 1% .125W F TC=0+-100	24546	C4-1/8-T0-1001-F
A22R32	0757-0444	1	4	RESISTOR 12.1K 1% .125W F TC=0+-100	24546	C4-1/8-T0-1212-F
A22R33	0757-0444	1		RESISTOR 12.1K 1% .125W F TC=0+-100	24546	C4-1/8-T0-1212-F
A22R34	0757-0444	1		RESISTOR 12.1K 1% .125W F TC=0+-100	24546	C4-1/8-T0-1212-F
A22R35	0757-0444	1		RESISTOR 12.1K 1% .125W F TC=0+-100	24546	C4-1/8-T0-1212-F
A22R36	0698-3394	0	1	RESISTOR 31.6 1% .5W F TC=0+-100	28480	0698-3394
A22R37	2100-3212	5		RESISTOR-TRMR 200 10% C 1-TRN	28480	2100-3212
A22R38	0757-0294	9		RESISTOR 17.8 1% .125W F TC=0+-100	19701	MF4C1/8-T0-17R8-F
A22R39	0757-0180	2		RESISTOR 31.6 1% .125W F TC=0+-100	28480	0757-0180
A22R40	0757-0382	6		RESISTOR 16.2 1% .125W F TC=0+-100	19701	MF4C1/8-T0-16R2-F
A22R41	0757-0180	2		RESISTOR 31.6 1% .125W F TC=0+-100	28480	0757-0180
A22R42	0698-3443	0		RESISTOR 287 1% .125W F TC=0+-100	24546	C4-1/8-T0-287R-F
A22R43	0757-0294	9		RESISTOR 17.8 1% .125W F TC=0+-100	19701	MF4C1/8-T0-17R8-F
A22R44	0698-3443	0		RESISTOR 287 1% .125W F TC=0+-100	24546	C4-1/8-T0-287R-F
A22R45	0698-4037	0		RESISTOR 46.4 1% .125W F TC=0+-100	24546	C4-1/8-T0-46R4-F
A22R46	0757-0180	2		RESISTOR 31.6 1% .125W F TC=0+-100	28480	0757-0180
A22R47	0757-0397	3		RESISTOR 68.1 1% .125W F TC=0+-100	24546	C4-1/8-T0-68R1-F
A22R48	0757-0180	2		RESISTOR 31.6 1% .125W F TC=0+-100	28480	0757-0180
A22R49	0698-0083	8		RESISTOR 1.96K 1% .125W F TC=0+-100	24546	C4-1/8-T0-1961-F
A22R50	0757-0401	0		RESISTOR 100 1% .125W F TC=0+-100	24546	C4-1/8-T0-101-F
A22R51	0757-0418	9		RESISTOR 619 1% .125W F TC=0+-100	24546	C4-1/8-T0-619R-F
A22R52	0698-4425	0		RESISTOR 1.54K 1% .125W F TC=0+-100	24546	C4-1/8-T0-1541-F
A22R53	0757-0417	8		RESISTOR 562 1% .125W F TC=0+-100	24546	C4-1/8-T0-562R-F
A22R54	0698-4444	3		RESISTOR 4.87K 1% .125W F TC=0+-100	24546	C4-1/8-T0-4871-F
A22R55	0757-0294	9		RESISTOR 17.8 1% .125W F TC=0+-100	19701	MF4C1/8-T0-17R8-F
A22R56	0757-0401	0		RESISTOR 100 1% .125W F TC=0+-100	24546	C4-1/8-T0-101-F
A22R57	0757-0294	9		RESISTOR 17.8 1% .125W F TC=0+-100	19701	MF4C1/8-T0-17R8-F
A22R58	0757-0294	9		RESISTOR 17.8 1% .125W F TC=0+-100	19701	MF4C1/8-T0-17R8-F
A22R59	0698-3443	0		RESISTOR 287 1% .125W F TC=0+-100	24546	C4-1/8-T0-287R-F
A22R60	0698-3443	0		RESISTOR 287 1% .125W F TC=0+-100	24546	C4-1/8-T0-287R-F
A22R61	0698-3441	8	7	RESISTOR 215 1% .125W F TC=0+-100	24546	C4-1/8-T0-215R-F
A22R62	0698-3431	6	3	RESISTOR 23.7 1% .125W F TC=0+-100	03888	PME55-1/8-T0-23R7-F
A22R63	0698-3441	8		RESISTOR 215 1% .125W F TC=0+-100	24546	C4-1/8-T0-215R-F
A22R64	0683-0395	4	1	RESISTOR 3.9 5% .25W FC TC=-400/+500	01121	CB39G5
A22R65	0757-0180	2		RESISTOR 31.6 1% .125W F TC=0+-100	28480	0757-0180
A22R66	0757-0401	0		RESISTOR 100 1% .125W F TC=0+-100	24546	C4-1/8-T0-101-F
A22R67	0698-0084	9	4	RESISTOR 2.15K 1% .125W F TC=0+-100	24546	C4-1/8-T0-2151-F
A22R68	2100-0554	5	1	RESISTOR-TRMR 500 10% C TOP-ADJ 1-TRN	28480	2100-0554
A22R69	0698-0082	7		RESISTOR 464 1% .125W F TC=0+-100	24546	C4-1/8-T0-4640-F
A22R70	0757-0401	0		RESISTOR 100 1% .125W F TC=0+-100	24546	C4-1/8-T0-101-F
A22R71	0757-0419	0	2	RESISTOR 681 1% .125W F TC=0+-100	24546	C4-1/8-T0-681R-F
A22R72	0757-0419	0		RESISTOR 681 1% .125W F TC=0+-100	24546	C4-1/8-T0-681R-F
A22R73	0757-0279	0	2	RESISTOR 3.16K 1% .125W F TC=0+-100	24546	C4-1/8-T0-3161-F
A22R74	0757-0418	9		RESISTOR 619 1% .125W F TC=0+-100	24546	C4-1/8-T0-619R-F
A22R75	0757-0180	2		RESISTOR 31.6 1% .125W F TC=0+-100	28480	0757-0180
A22R76	0757-0421	4	2	RESISTOR 825 1% .125W F TC=0+-100	24546	C4-1/8-T0-825R-F
A22R77	0757-0401	0		RESISTOR 100 1% .125W F TC=0+-100	24546	C4-1/8-T0-101-F
A22R78	0757-0401	0		RESISTOR 100 1% .125W F TC=0+-100	24546	C4-1/8-T0-101-F

See introduction to this section for ordering information.
 * Indicates factory selected value.

Table 6-3. Replaceable Parts (continued)

Reference Designator	HP Part Number	C D	Qty.	Description	Mfr Code	Mfr Part Number
A22R79	0757-0421	4		RESISTOR 825 1% .125W F TC=0+-100	24546	C4-1/8-T0-825R-F
A22R80	0698-3438	3	2	RESISTOR 147 1% .125W F TC=0+-100	24546	C4-1/8-T0-147R-F
A22R81				NOT ASSIGNED		
A22R82	0757-0180	2		RESISTOR 31.6 1% .125W F TC=0+-100	28480	0757-0180
A22R83	0757-0442	9	21	RESISTOR 10K 1% .125W F TC=0+-100	24546	C4-1/8-T0-1002-F
A22R84	0757-0442	9		RESISTOR 10K 1% .125W F TC=0+-100	24546	C4-1/8-T0-1002-F
A22R85	0698-8827	4	5	RESISTOR 1M 1% .125W F TC=0+-100	28480	0698-8827
A22R86	0757-0280	3		RESISTOR 1K 1% .125W F TC=0+-100	24546	C4-1/8-T0-1001-F
A22R87	0757-0280	3		RESISTOR 1K 1% .125W F TC=0+-100	24546	C4-1/8-T0-1001-F
A22R88	0698-8827	4		RESISTOR 1M 1% .125W F TC=0+-100	28480	0698-8827
A22R89	0698-8827	4		RESISTOR 1M 1% .125W F TC=0+-100	28480	0698-8827
A22R90	2100-3212	5		RESISTOR-TRMR 200 10% C 1-TRN	28480	2100-3212
A22R91	0698-4037	0		RESISTOR 46.4 1% .125W F TC=0+-100	24546	C4-1/8-T0-46R4-F
A22R92	0757-0382	6		RESISTOR 16.2 1% .125W F TC=0+-100	19701	MF4C1/8-T0-16R2-F
A22R93	0757-0180	2		RESISTOR 31.6 1% .125W F TC=0+-100	28480	0757-0180
A22R94	0757-0397	3		RESISTOR 68.1 1% .125W F TC=0+-100	24546	C4-1/8-T0-68R1-F
A22R95	0698-4037	0		RESISTOR 46.4 1% .125W F TC=0+-100	24546	C4-1/8-T0-46R4-F
A22R96	0757-0397	3		RESISTOR 68.1 1% .125W F TC=0+-100	24546	C4-1/8-T0-68R1-F
A22R97	0757-0180	2		RESISTOR 31.6 1% .125W F TC=0+-100	28480	0757-0180
A22R98	0698-0083	8		RESISTOR 1.96K 1% .125W F TC=0+-100	24546	C4-1/8-T0-1961-F
A22R99	0757-0401	0		RESISTOR 100 1% .125W F TC=0+-100	24546	C4-1/8-T0-101-F
A22R100	0757-0418	9		RESISTOR 619 1% .125W F TC=0+-100	24546	C4-1/8-T0-619R-F
A22R101	0698-4425	0		RESISTOR 1.54K 1% .125W F TC=0+-100	24546	C4-1/8-T0-1541-F
A22R102	0698-4444	3		RESISTOR 4.87K 1% .125W F TC=0+-100	24546	C4-1/8-T0-4871-F
A22R103	0757-0417	8		RESISTOR 562 1% .125W F TC=0+-100	24546	C4-1/8-T0-562R-F
A22R104	0757-0401	3		RESISTOR 100 1% .125W F TC=0+-100	24546	C4-1/8-T0-101-F
A22R105	0757-0294	9		RESISTOR 17.8 1% .125W F TC=0+-100	19701	MF4C1/8-T0-17R8-F
A22R106	0757-0294	9		RESISTOR 17.8 1% .125W F TC=0+-100	19701	MF4C1/8-T0-17R8-F
A22R107	0698-3443	0		RESISTOR 287 1% .125W F TC=0+-100	24546	C4-1/8-T0-287R-F
A22R108	0757-0294	9		RESISTOR 17.8 1% .125W F TC=0+-100	19701	MF4C1/8-T0-17R8-F
A22R109	0698-3443	0		RESISTOR 287 1% .125W F TC=0+-100	24546	C4-1/8-T0-287R-F
A22R110	0698-3439	4		RESISTOR 178 1% .125W F TC=0+-100	24546	C4-1/8-T0-178R-F
A22R111	0757-0180	2		RESISTOR 31.6 1% .125W F TC=0+-100	28480	0757-0180
A22R112	0698-3439	4		RESISTOR 178 1% .125W F TC=0+-100	24546	C4-1/8-T0-178R-F
A22R113	0698-3441	8		RESISTOR 215 1% .125W F TC=0+-100	24546	C4-1/8-T0-215R-F
A22R114	0698-3431	6		RESISTOR 23.7 1% .125W F TC=0+-100	03888	PKE55-1/8-T0-23R7-F
A22R115	0698-3441	8		RESISTOR 215 1% .125W F TC=0+-100	24546	C4-1/8-T0-215R-F
A22R116	0757-0461	2		RESISTOR 68.1K 1% .125W F TC=0+-100	24546	C4-1/8-T0-6812-F
A22R117	0757-0442	9		RESISTOR 10K 1% .125W F TC=0+-100	24546	C4-1/8-T0-1002-F
A22R118	0757-0442	9		RESISTOR 10K 1% .125W F TC=0+-100	24546	C4-1/8-T0-1002-F
A22R119	0757-0442	9		RESISTOR 10K 1% .125W F TC=0+-100	24546	C4-1/8-T0-1002-F
A22R120	0698-0083	8		RESISTOR 1.96K 1% .125W F TC=0+-100	24546	C4-1/8-T0-1961-F
A22R121	0698-0083	8		RESISTOR 1.96K 1% .125W F TC=0+-100	24546	C4-1/8-T0-1961-F
A22R122	0757-0394	0	4	RESISTOR 51.1 1% .125W F TC=0+-100	24546	C4-1/8-T0-51R1-F
A22R123	0757-0394	0		RESISTOR 51.1 1% .125W F TC=0+-100	24546	C4-1/8-T0-51R1-F
A22R124	2100-3210	6	2	RESISTOR-TRMR 10K 10% C TOP-ADJ 1-TRN	28480	2100-3210
A22R125	0698-8827	4		RESISTOR 1M 1% .125W F TC=0+-100	28480	0698-8827
A22R126	0698-8827	4		RESISTOR 1M 1% .125W F TC=0+-100	28480	0698-8827
A22R127	2100-3210	6		RESISTOR-TRMR 10K 10% C TOP-ADJ 1-TRN	28480	2100-3210

See introduction to this section for ordering information.
 * Indicates factory selected value.

Table 6-3. Replaceable Parts (continued)

Reference Designator	HP Part Number	C D	Qty.	Description	Mfr Code	Mfr Part Number
A22R128	0757-0465	6	2	RESISTOR 100K 1% .125W F TC=0+-100	24546	C4-1/8-T0-1003-F
A22R129	0757-0465	6		RESISTOR 100K 1% .125W F TC=0+-100	24546	C4-1/8-T0-1003-F
A22R130	0698-0084	9		RESISTOR 2.15K 1% .125W F TC=0+-100	24546	C4-1/8-T0-2151-F
A22R131	0698-0084	9		RESISTOR 2.15K 1% .125W F TC=0+-100	24546	C4-1/8-T0-2151-F
A22R132	0698-3441	8		RESISTOR 215 1% .125W F TC=0+-100	24546	C4-1/8-T0-215R-F
A22R133	0698-3431	6		RESISTOR 23.7 1% .125W F TC=0+-100	03888	PME55-1/8-T0-23R7-F
A22R134	0698-3441	8		RESISTOR 215 1% .125W F TC=0+-100	24546	C4-1/8-T0-215R-F
A22R135	0698-4037	0		RESISTOR 46.4 1% .125W F TC=0+-100	24546	C4-1/8-T0-46R4-F
A22R136	0757-0382	6		RESISTOR 16.2 1% .125W F TC=0+-100	19701	MF4C1/8-T0-16R2-F
A22R137	0757-0382	6		RESISTOR 16.2 1% .125W F TC=0+-100	19701	MF4C1/8-T0-16R2-F
A22R138	0757-0382	6		RESISTOR 16.2 1% .125W F TC=0+-100	19701	MF4C1/8-T0-16R2-F
A22R139	2100-0558	6	2	RESISTOR-TRMR 20K 10%	28480	2100-0558
A22R140	2100-0558	6		RESISTOR-TRMR 20K 10%	28480	2100-0558
A22R141	0757-0442	8		RESISTOR 10K 1% .125W		
A22R142	0757-0442	8		RESISTOR 10K 1% .125W		
A22R143	0757-0442	9		RESISTOR 10K 1% .125W F TC=0+-100	24546	C4-1/8-T0-1002-F
A22R144	0757-0420	3	1	RESISTOR 750 1% .125W F TC=0+-100	24546	C4-1/8-T0-751-F
A22R145	0757-0442	9		RESISTOR 10K 1% .125W F TC=0+-100	24546	C4-1/8-T0-1002-F
A22R146	0698-3160	8	2	RESISTOR 31.6K 1% .125W F TC=0+-100	24546	C4-1/8-T0-3162-F
A22R147	0757-0442	9		RESISTOR 10K 1% .125W F TC=0+-100	24546	C4-1/8-T0-1002-F
A22R148	0698-3444	3	6	RESISTOR 316 1% .125W		
A22R149	0698-3444	3		RESISTOR 316 1% .125W		
A22R150	0757-0442	9		RESISTOR 10K 1% .125W F TC=0+-100	24546	C4-1/8-T0-1002-F
A22R151	0698-3160	8		RESISTOR 31.6K 1% .125W F TC=0+-100	24546	C4-1/8-T0-3162-F
A22R152	0757-0290	5	2	RESISTOR 6.19K 1% .125W F TC=0+-100	19701	MF4C1/8-T0-6191-F
A22R153	0757-0209	5		RESISTOR 6.19K 1% .125W F TC=0+-100	19701	MF4C1/8-T0-6191-F
A22R154	0757-0200	7	2	RESISTOR 5.62K		
A22R155	0757-0443	0	2	RESISTOR 11K		
A22R156	0698-3450	9	2	RESISTOR 42.2K 1% .125W F TC=0+-100	24546	C4-1/8-T0-4222-F
A22R157	0698-3450	9		RESISTOR 42.2K 1% .125W F TC=0+-100	24546	C4-1/8-T0-4222-F
A22R158	0757-0200	7		RESISTOR 5.62K		
A22R159	0757-0443	0		RESISTOR 11K		
A22R160	0757-0442	9		RESISTOR 10K 1% .125W F TC=0+-100	24546	C4-1/8-T0-1002-F
A22R161	0757-0442	9		RESISTOR 10K 1% .125W F TC=0+-100	24546	C4-1/8-T0-1002-F
A22R162	0757-0397	3		RESISTOR 68.1 1% .125W F TC=0+-100	24546	C4-1/8-T0-68R1-F
A22R163	0698-3439	4	1	RESISTOR 178 1% .125W F TC=0+-100	24546	C4-1/8-T0-178R-F
A22R164	0698-4406	7	1	RESISTOR 115 1% .125W F TC=0+-100	24546	C4-1/8-T0-115R-F
A22R165	0757-0395	1		RESISTOR 56.2 1% .125W F TC=0+-100	24546	C4-1/8-T0-56R2-F
A22R166	0757-0180	2		RESISTOR 31.6 1% .125W F TC=0+-100	28480	0757-0180
A22R167	0757-0180	2		RESISTOR 31.6 1% .125W F TC=0+-100	28480	0757-0180
A22R168	0698-3437	2	1	RESISTOR 133 1% .125W F TC=0+-100	24546	C4-1/8-T0-133R-F
A22R169	0757-0398	4	1	RESISTOR 75 1% .125W F TC=0+-100	24546	C4-1/8-T0-75R0-F
A22R170	0757-0401	0		RESISTOR 100 1% .125W F TC=0+-100	24546	C4-1/8-T0-101-F
A22R171	0757-0401	0		RESISTOR 100 1% .125W F TC=0+-100	24546	C4-1/8-T0-101-F
A22R172	0757-0280	3		RESISTOR 1K 1% .125W F TC=0+-100	24546	C4-1/8-T0-1001-F
A22R173	0698-0084	9		RESISTOR 2.15K 1% .125W F TC=0+-100	24546	C4-1/8-T0-2151-F
A22R174	0757-0405	4		RESISTOR 162 1% .125W F TC=0+-100	24546	C4-1/8-T0-162R-F
A22R175	0698-3435	0		RESISTOR 38.3 1% .125W F TC=0+-100	24546	C4-1/8-T0-38R3-F
A22R176	0757-0405	4		RESISTOR 162 1% .125W F TC=0+-100	24546	C4-1/8-T0-162R-F

See introduction to this section for ordering information.
 * Indicates factory selected value.

Table 6-3. Replaceable Parts (continued)

Reference Designator	HP Part Number	C D	Qty.	Description	Mfr Code	Mfr Part Number
A22R177	0698-4037	0		RESISTOR 46.4 1% .125W F TC=0+-100	24546	C4-1/8-T0-46R4-F
A22R178	0698-3438	3		RESISTOR 147 1% .125W F TC=0+-100	24546	C4-1/8-T0-147R-F
A22R179	2100-3252		2	RESISTOR 5K 10%		
A22R180	2100-3252			RESISTOR 5K 10%		
A22R181	0757-0442	9		RESISTOR 10K 1% .125W F TC=0+-100	24546	C4-1/8-T0-1002-F
A22R182	0757-0442	9		RESISTOR 10K 1% .125W F TC=0+-100	24546	C4-1/8-T0-1002-F
A22R183	0757-0346	2		RESISTOR 10 1% .125W F TC=0+-100	24546	C4-1/8-T0-10R0-F
A22R184	0757-0346	2		RESISTOR 10 1% .125W F TC=0+-100	24546	C4-1/8-T0-10R0-F
A22R185	0698-0082	7		RESISTOR 464 1% .125W F TC=0+-100	24546	C4-1/8-T0-4640-F
A22R186	0757-0379	1		RESISTOR 12.1 1% .125W F TC=0+-100	19701	MF4C1/8-T0-12R1-F
A22R187	0698-0082	7		RESISTOR 464 1% .125W F TC=0+-100	24546	C4-1/8-T0-4640-F
A22R188	0757-0346	2		RESISTOR 10 1% .125W F TC=0+-100	24546	C4-1/8-T0-10R0-F
A22R189	0698-3444			RESISTOR 316 1% .125W		
A22R190	0698-3444			RESISTOR 316 1% .125W		
A22R191	0757-0394	0		RESISTOR 51.1 1% .125W F TC=0+-100	24546	C4-1/8-T0-51R1-F
A22R192	0698-3444			RESISTOR 316 1% .125W		
A22R193	0698-3444			RESISTOR 316 1% .125W		
A22R194	0757-0294	9		RESISTOR 17.8 1% .125W F TC=0+-100	19701	MF4C1/8-T0-17R8-F
A22R195	0757-0180	2		RESISTOR 31.6 1% .125W F TC=0+-100	28480	0757-0180
A22R196				NOT ASSIGNED		
A22R197				NOT ASSIGNED		
A22R198	1810-0275	1	1	NETWORK-RES 10-SIP1.OK OHM X 9	01121	210A102
A22R199	0757-0442	9		RESISTOR 10K 1% .125W F TC=0+-100	24546	C4-1/8-T0-1002-F
A22R200	0757-0984	4	2	RESISTOR 10 1% .5W F TC=0+-100	28480	0757-0984
A22R201	0757-0984	4		RESISTOR 10 1% .5W F TC=0+-100	28480	0757-0984
A22R202				NOT ASSIGNED		
A22R203	0757-0442	9		RESISTOR 10K 1% .125W F TC=0+-100	24546	C4-1/8-T0-1002-F
A22R204	0757-0279	0		RESISTOR 3.16K 1% .125W F TC=0+-100	24546	C4-1/8-T0-3161-F
A22R205	0698-0082	7		RESISTOR 464 1% .125W F TC=0+-100	24546	C4-1/8-T0-4640-F
A22R206	0683-0335	2	2	RESISTOR 3.3 5% .25W FC TC=-400/+500	01121	CB33G5
A22R207	0683-0335	2		RESISTOR 3.3 5% .25W FC TC=-400/+500	01121	CB33G5
A22R208	0757-0442	9		RESISTOR 10K 1% .125W F TC=0+-100	24546	C4-1/8-T0-1002-F
A22R209	0757-0442	9		RESISTOR 10K 1% .125W F TC=0+-100	24546	C4-1/8-T0-1002-F
A22R210	0757-0442	9		RESISTOR 10K 1% .125W F TC=0+-100	24546	C4-1/8-T0-1002-F
A22R211	0757-0442	9		RESISTOR 10K 1% .125W F TC=0+-100	24546	C4-1/8-T0-1002-F
A22R212	0698-3441	8		RESISTOR 215 1% .125W F TC=0+-100	24546	C4-1/8-T0-215R-F
A22R213	0757-0395	1		RESISTOR 56.2 1% .125W F TC=0+-100	24546	C4-1/8-T0-56R2-F
A22R214	0757-0438	3	2	RESISTOR 5.11K 1% .125W F TC=0+-100	24546	C4-1/8-T0-5111-F
A22R215	0757-0438	3		RESISTOR 5.11K 1% .125W F TC=0+-100	24546	C4-1/8-T0-5111-F
A22R216	0757-0394	0		RESISTOR 51.1 1% .125W F TC=0+-100	24546	C4-1/8-T0-51R1-F
A22R217	0757-0280	3		RESISTOR 1K 1% .125W F TC=0+-100	24546	C4-1/8-T0-1001-F
A22R218	0757-0280	3		RESISTOR 1K 1% .125W F TC=0+-100	24546	C4-1/8-T0-1001-F
A22R219	0698-3428			RESISTOR 14.7 1%		
A22T1	9100-4461	8	1	PLS TRANS 1:3:3	28480	9100-4461
A22T2	9100-4359	3	1	TRANSFORMER RF XFMR;Z RATIO: 1:4;FOPR	28480	9100-4359
A22U1	1826-1311	1	4	IC RF/IF AMPL WB 4-DIP-P PKG	28480	1826-1311
A22U2	1826-0476	7	1	IC SWITCH ANLG 8-DIP-P PKG	01295	TL601CP
A22U3	04194-81804	9	2	HIC PHASE DET	28480	04194-81804
A22U4	04194-81804	9		HIC PHASE DET	28480	04194-81804

See introduction to this section for ordering information.
 * Indicates factory selected value.

Table 6-3. Replaceable Parts (continued)

Reference Designator	HP Part Number	C D	Qty.	Description	Mfr Code	Mfr Part Number
A22U5	1826-0147	9	1	IC 7812 V RGLTR TO-220	04713	MC7812CP
A22U6	1826-0221	0	1	IC V RGLTR TO-220	04713	MC7912CT
A22U7	1826-0962	6	1	IC LF412CN		LF412CN
A22U8	1826-0635	0	2	IC OP AMP LOW-OFS 8-DIP-P PKG	06665	OP-07CP
A22U9	1826-0635	0		IC OP AMP LOW-OFS 8-DIP-P PKG	06665	OP-07CP
A22U10	1826-0138	8	1	IC COMPARATOR GP QUAD 14-DIP-P PKG	01295	LM339N
A22U11	1820-1194	6	1	IC CNTR TTL LS BIN UP/DOWN SYNCHRO	01295	SN74LS193N
A22U12	1820-1112	8	1	IC FF TTL LS D-TYPE POS-EDGE-TRIG	01295	SN74LS74AN
A22U13	1820-1433	6	6	IC SHF-RGTR TTL LS R-S SERIAL-IN PRL-OUT	01295	SN74LS164N
A22U14	1820-1730	6	3	IC FF TTL LS D-TYPE POS-EDGE-TRIG COM	01295	SN74LS273N
A22U15	1826-0122	0	1	IC 7805 V RGLTR TO-220	07263	7805UC
A22U16	1826-1311	1		IC RF/IF AMPL WB 4-DIP-P PKG	28480	1826-1311
A22U17	1826-1311	1		IC RF/IF AMPL WB 4-DIP-P PKG	28480	1826-1311
A22U18	1826-1328	0	2	IC OP AMP LOW-NOISE DUAL 8-DIP-P PKG	28480	1826-1328
A22U19	1820-1314	2	1	IC MULTIPLXR 4-CHAN-ANLG DUAL 16-DIP-P	3L585	CD4052BE
A22U20	1820-1208	3	1	IC GATE TTL LS OR QUAD 2-INP	01295	SN74LS32N
A22U21	1820-1201	6	1	IC GATE TTL LS AND QUAD 2-INP	01295	SN74LS08N
A22U22	1820-1197	9	1	IC GATE TTL LS NAND QUAD 2-INP	01295	SN74LS00N
A22U23	1820-1433	6		IC SHF-RGTR TTL LS R-S SERIAL-IN PRL-OUT	01295	SN74LS164N
A22U24	1820-1433	6		IC SHF-RGTR TTL LS R-S SERIAL-IN PRL-OUT	01295	SN74LS164N
A22U25	1826-1311	1		IC RF/IF AMPL WB 4-DIP-P PKG	28480	1826-1311
A22U26	1826-0519	9	1	IC OP AMP LOW-BIAS-H-IMP 8-DIP-P PKG	01295	TL071CP
A22U27	1826-1328	0		IC OP AMP LOW-NOISE DUAL 8-DIP-P PKG	28480	1826-1328
A22U28	1826-1386	4	1	IC AD7541AKN	28480	1826-1386
A22U29	1820-2711	5	4	IC DRVR TTL LS LINE DRVR OCTL	01295	SN74LS541N
A22U30	1820-2711	5		IC DRVR TTL LS LINE DRVR OCTL	01295	SN74LS541N
A22U31	1820-1197	1	1	IC INV TTL LS HEX 1-INP	01295	SN74LS00N
A22U32	1820-1433	6		IC SHF-RGTR TTL LS R-S SERIAL-IN PRL-OUT	01295	SN74LS164N
A22U33	1820-2711	5		IC DRVR TTL LS LINE DRVR OCTL	01295	SN74LS541N
A22U34	04194-81807	2	1	HIC VECTOR GEN	28480	04194-81807
A22U35	1826-0521	3	1	IC OP AMP LOW-BIAS-H-IMP DUAL 8-DIP-P	01295	TL072CP
A22U36	1820-1730	6		IC FF TTL LS D-TYPE POS-EDGE-TRIG COM	01295	SN74LS273N
A22U37	1820-1433	6		IC SHF-RGTR TTL LS R-S SERIAL-IN PRL-OUT	01295	SN74LS164N
A22U38	1820-1730	6		IC FF TTL LS D-TYPE POS-EDGE-TRIG COM	01295	SN74LS273N
A22U39	1820-1433	6		IC SHF-RGTR TTL LS R-S SERIAL-IN PRL-OUT	01295	SN74LS164N
A22U40	1820-2711	5		IC DRVR TTL LS LINE DRVR OCTL	01295	SN74LS541N

See introduction to this section for ordering information.
 * Indicates factory selected value.

Table 6-3. Replaceable Parts

Reference Designator	HP Part Number	C D	Qty.	Description	Mfr Code	Mfr Part Number
A23	04194-66523	7	1	NULL DETECTOR BOARD ASSEMBLY	28480	04194-66523
A23C1	0160-4834	6	2	CAPACITOR-FXD .047UF +-10% 100VDC CER	28480	0160-4834
A23C2	0180-3469	3	15	CAPACITOR-FXD 100UF +-20% 25VDC AL	28480	0180-3469
A23C3	0160-4830	2	2	CAPACITOR-FXD 2200PF +-10% 100VDC CER	28480	0160-4830
A23C4	0160-4834	6		CAPACITOR-FXD .047UF +-10% 100VDC CER	28480	0160-4834
A23C5	0180-3582	1	5	CAPACITOR-FXD 4.7UF +-20% 50VDC AL	28480	0180-3582
A23C6	0160-0575	4	2	CAPACITOR-FXD 0.047UF +-10% 50VDC AL	28480	0160-0575
A23C7	0160-4831	3	2	CAPACITOR-FXD 4700PF +-10% 100VDC CER	28480	0160-4831
A23C8	0160-4831	3		CAPACITOR-FXD 4700PF +-10% 100VDC CER	28480	0160-4831
A23C9	0160-4830	2		CAPACITOR-FXD 2200PF +-10% 100VDC CER	28480	0160-4830
A23C10	0160-4832	4	13	CAPACITOR-FXD .01UF +-10% 100VDC CER	28480	0160-4832
A23C11	0160-4833	5	2	CAPACITOR-FXD .022UF +-10% 100VDC CER	28480	0160-4833
A23C12	0160-4833	5		CAPACITOR-FXD .022UF +-10% 100VDC CER	28480	0160-4833
A23C13	0160-4832	4		CAPACITOR-FXD .01UF +-10% 100VDC CER	28480	0160-4832
A23C14	0180-3582	1		CAPACITOR-FXD 4.7UF +-20% 50VDC AL	28480	0180-3582
A23C15	0160-4808	4	2	CAPACITOR-FXD 470PF +-5% 100VDC CER	28480	0160-4808
A23C16	0180-3469	3		CAPACITOR-FXD 100UF +-20% 25VDC AL	28480	0180-3469
A23C17	0160-4741	4	1	CAPACITOR-FXD .22UF +-10% 50VDC CER	28480	0160-4741
A23C18	0160-0575	4	1	CAPACITOR-FXD .047UF +-20% 50VDC CER	28480	0160-0575
A23C19	0160-4441	1	1	CAPACITOR-FXD .47UF +-10% 50VDC CER	28480	0160-4441
A23C20	0180-3469	3		CAPACITOR-FXD 100UF +-20% 25VDC AL	28480	0180-3469
A23C21	0180-3363	6	16	CAPACITOR-FXD 22UF +-20% 25VDC AL	28480	0180-3363
A23C22	0180-3363	6		CAPACITOR-FXD 22UF +-20% 25VDC AL	28480	0180-3363
A23C23	0180-3469	3		CAPACITOR-FXD 100UF +-20% 25VDC AL	28480	0180-3469
A23C24	0160-4808	4		CAPACITOR-FXD 470PF +-5% 100VDC CER	28480	0160-4808
A23C25	0180-3469	3		CAPACITOR-FXD 100UF +-20% 25VDC AL	28480	0180-3469
A23C26	0180-3469	3		CAPACITOR-FXD 100UF +-20% 25VDC AL	28480	0180-3469
A23C27	0180-3363	6		CAPACITOR-FXD 22UF +-20% 25VDC AL	28480	0180-3363
A23C28	0160-4832	4		CAPACITOR-FXD .01UF +-10% 100VDC CER	28480	0160-4832
A23C29	0180-3363	6		CAPACITOR-FXD 22UF +-20% 25VDC AL	28480	0180-3363
A23C30	0180-3469	3		CAPACITOR-FXD 100UF +-20% 25VDC AL	28480	0180-3469
A23C31	0180-3363	6		CAPACITOR-FXD 22UF +-20% 25VDC AL	28480	0180-3363
A23C32	0180-3582	1		CAPACITOR-FXD 4.7UF +-20% 50VDC AL	28480	0180-3582
A23C33	0160-4801	7	2	CAPACITOR-FXD 100PF +-5% 100VDC CER	28480	0160-4801
A23C34	0160-4802	8	4	CAPACITOR-FXD 82PF +-5% 100VDC CER 0+-30	28480	0160-4802
A23C35	0160-4802	8		CAPACITOR-FXD 82PF +-5% 100VDC CER 0+-30	28480	0160-4802
A23C36	0160-4802	8		CAPACITOR-FXD 82PF +-5% 100VDC CER 0+-30	28480	0160-4802
A23C37	0160-4802	8		CAPACITOR-FXD 82PF +-5% 100VDC CER 0+-30	28480	0160-4802
A23C38	0160-4801	7		CAPACITOR-FXD 100PF +-5% 100VDC CER	28480	0160-4801
A23C39	0160-4805	1	1	CAPACITOR-FXD 47PF +-5% 100VDC CER 0+-30	28480	0160-4805
A23C40	0160-4835	7	2	CAPACITOR-FXD .1UF +-10% 50VDC CER	28480	0160-4835
A23C41	0180-3469	3		CAPACITOR-FXD 100UF +-20% 25VDC AL	28480	0180-3469
A23C42	0180-3582	1		CAPACITOR-FXD 4.7UF +-20% 50VDC AL	28480	0180-3582
A23C43	0160-4832	4		CAPACITOR-FXD .01UF +-10% 100VDC CER	28480	0160-4832
A23C44	0160-4832	4		CAPACITOR-FXD .01UF +-10% 100VDC CER	28480	0160-4832
A23C45	0180-3363	6		CAPACITOR-FXD 22UF +-20% 25VDC AL	28480	0180-3363
A23C46	0160-4832	4		CAPACITOR-FXD .01UF +-10% 100VDC CER	28480	0160-4832
A23C47	0180-3363	6		CAPACITOR-FXD 22UF +-20% 25VDC AL	28480	0180-3363

See introduction to this section for ordering information.
 * Indicates factory selected value.

Table 6-3. Replaceable Parts (continued)

Reference Designator	HP Part Number	C D	Qty.	Description	Mfr Code	Mfr Part Number
A23C48	0180-3363	6		CAPACITOR-FXD 22UF +-20% 25VDC AL	28480	0180-3363
A23C49	0180-3431	9	2	CAPACITOR-FXD 220UF +-20% 10VDC AL	28480	0180-3431
A23C50	0180-3431	9		CAPACITOR-FXD 220UF +-20% 10VDC AL	28480	0180-3431
A23C51	0160-4832	4		CAPACITOR-FXD .01UF +-10% 100VDC CER	28480	0160-4832
A23C52	0180-3363	6		CAPACITOR-FXD 22UF +-20% 25VDC AL	28480	0180-3363
A23C53	0180-3363	6		CAPACITOR-FXD 22UF +-20% 25VDC AL	28480	0180-3363
A23C54	0160-4832	4		CAPACITOR-FXD .01UF +-10% 100VDC CER	28480	0160-4832
A23C55	0180-3469	3		CAPACITOR-FXD 100UF +-20% 25VDC AL	28480	0180-3469
A23C56	0180-3469	3		CAPACITOR-FXD 100UF +-20% 25VDC AL	28480	0180-3469
A23C57	0180-3469	3		CAPACITOR-FXD 100UF +-20% 25VDC AL	28480	0180-3469
A23C58	0180-3469	3		CAPACITOR-FXD 100UF +-20% 25VDC AL	28480	0180-3469
A23C59	0160-4822	2	5	CAPACITOR-FXD 1000PF +-5% 100VDC CER	28480	0160-4822
A23C60	0180-3363	6		CAPACITOR-FXD 22UF +-20% 25VDC AL	28480	0180-3363
A23C61	0180-3469	3		CAPACITOR-FXD 100UF +-20% 25VDC AL	28480	0180-3469
A23C62	0180-3469	3		CAPACITOR-FXD 100UF +-20% 25VDC AL	28480	0180-3469
A23C63	0180-3363	6		CAPACITOR-FXD 22UF +-20% 25VDC AL	28480	0180-3363
A23C64	0160-4832	4		CAPACITOR-FXD .01UF +-10% 100VDC CER	28480	0160-4832
A23C65	0160-4832	4		CAPACITOR-FXD .01UF +-10% 100VDC CER	28480	0160-4832
A23C66	0180-3469	3		CAPACITOR-FXD 100UF +-20% 25VDC AL	28480	0180-3469
A23C67	0180-3363	6		CAPACITOR-FXD 22UF +-20% 25VDC AL	28480	0180-3363
A23C68	0180-3363	6		CAPACITOR-FXD 22UF +-20% 25VDC AL	28480	0180-3363
A23C69	0160-4822	2		CAPACITOR-FXD 1000PF +-5% 100VDC CER	28480	0160-4822
A23C70	0160-4832	4		CAPACITOR-FXD .01UF +-10% 100VDC CER	28480	0160-4832
A23C71	0160-4822	2		CAPACITOR-FXD 1000PF +-5% 100VDC CER	28480	0160-4822
A23C72	0160-4832	4		CAPACITOR-FXD .01UF +-10% 100VDC CER	28480	0160-4832
A23C73	0160-4832	4		CAPACITOR-FXD .01UF +-10% 100VDC CER	28480	0160-4832
A23C74	0160-4835	7		CAPACITOR-FXD .1UF +-10% 50VDC CER	28480	0160-4835
A23C75	0160-4822	2		CAPACITOR-FXD 1000PF +-5% 100VDC CER	28480	0160-4822
A23C76	0160-4822	2		CAPACITOR-FXD 1000PF +-5% 100VDC CER	28480	0160-4822
A23C77	0180-3363			CAPACITOR-FXD 22UF 25V		0180-3363
A23C78	0180-3363			CAPACITOR-FXD 22UF 25V		0180-3363
A23CR1	1901-1065	2	2	DIODE-PWR RECT 1N4936 400V 1A 200NS	14936	1N4936
A23CR2	1901-1065	2		DIODE-PWR RECT 1N4936 400V 1A 200NS	14936	1N4936
A23CR3	1901-0050	3	11	DIODE-SWITCHING 80V 200MA 2NS DO-35	28480	1901-0050
A23CR4	1902-0954	8	2	DIODE-ZNR 6.8V 5% DO-35 PD=.4W TC=+.057%	28480	1902-0954
A23CR5	1901-0050	3		DIODE-SWITCHING 80V 200MA 2NS DO-35	28480	1901-0050
A23CR6	1901-0050	3		DIODE-SWITCHING 80V 200MA 2NS DO-35	28480	1901-0050
A23CR7	1902-0954	8		DIODE-ZNR 6.8V 5% DO-35 PD=.4W TC=+.057%	28480	1902-0954
A23CR8	1901-0050	3		DIODE-SWITCHING 80V 200MA 2NS DO-35	28480	1901-0050
A23CR9	1901-0050	3		DIODE-SWITCHING 80V 200MA 2NS DO-35	28480	1901-0050
A23CR10	1901-0050	3		DIODE-SWITCHING 80V 200MA 2NS DO-35	28480	1901-0050
A23CR11	1901-0050	3		DIODE-SWITCHING 80V 200MA 2NS DO-35	28480	1901-0050
A23CR12	1901-0050	3		DIODE-SWITCHING 80V 200MA 2NS DO-35	28480	1901-0050
A23CR13	1901-0050	3		DIODE-SWITCHING 80V 200MA 2NS DO-35	28480	1901-0050
A23CR14	1902-0948	0	1	DIODE-ZNR 3.9V 5% DO-35 PD=.4W TC=-.012%	28480	1902-0948
A23CR15	1901-0050	3		DIODE-SWITCHING 80V 200MA 2NS DO-35	28480	1901-0050
A23CR16	1901-0050	3		DIODE-SWITCHING 80V 200MA 2NS DO-35	28480	1901-0050
A23E1	0955-0252	9	1	U-WAVE MIXER 250MHZ MAX	28480	0955-0252

See introduction to this section for ordering information.
 * Indicates factory selected value.

Table 6-3. Replaceable Parts (continued)

Reference Designator	HP Part Number	C D	Qty.	Description	Mfr Code	Mfr Part Number
A23F1	2110-0513	7	1	FUSE .125A 125V NTD .348X.25	75915	273.125
A23J1	1250-0257	1	3	CONNECTOR-RF SMB M PC 50-OHM	28480	1250-0257
A23J2	1250-0257	1		CONNECTOR-RF SMB M PC 50-OHM	28480	1250-0257
A23J3	1250-0257	1		CONNECTOR-RF SMB M PC 50-OHM	28480	1250-0257
A23J4	1200-0541	1	1	SOCKET-IC 24-CONT DIP DIP-SLDR	28480	1200-0541
A23L1	9140-1094	3	3	COIL 47UH	28480	9140-1094
A23L2	9140-0137	1	2	INDUCTOR RF-CH-MLD 1MH 5% .2DX.45LG Q=60	28480	9140-0137
A23L3	9140-1094	3		COIL 47UH	28480	9140-1094
A23L4	9100-1644	3	1	INDUCTOR RF-CH-MLD 330UH 5% .2DX.45LG	28480	9100-1644
A23L5	9140-1094	3		COIL 47UH	28480	9140-1094
A23L6	9100-0368	6	2	INDUCTOR RF-CH-MLD 330NH 10% .105DX.26LG	28480	9100-0368
A23L7	9140-0179	1	6	INDUCTOR RF-CH-MLD 22UH 10% .166DX.385LG	28480	9140-0179
A23L8	9140-0179	1		INDUCTOR RF-CH-MLD 22UH 10% .166DX.385LG	28480	9140-0179
A23L9	9140-0179	1		INDUCTOR RF-CH-MLD 22UH 10% .166DX.385LG	28480	9140-0179
A23L10	9100-2252	1	2	INDUCTOR RF-CH-MLD 270NH 10% .105DX.26LG	28480	9100-2252
A23L11	9100-0368	6		INDUCTOR RF-CH-MLD 330NH 10% .105DX.26LG	28480	9100-0368
A23L12	9100-2252	1		INDUCTOR RF-CH-MLD 270NH 10% .105DX.26LG	28480	9100-2252
A23L13	9140-0179	1		INDUCTOR RF-CH-MLD 22UH 10% .166DX.385LG	28480	9140-0179
A23L14	9140-0179	1		INDUCTOR RF-CH-MLD 22UH 10% .166DX.385LG	28480	9140-0179
A23L15	9140-0114	4	2	INDUCTOR RF-CH-MLD 10UH 10% .166DX.385LG	28480	9140-0114
A23L16	9140-0114	4		INDUCTOR RF-CH-MLD 10UH 10% .166DX.385LG	28480	9140-0114
A23L17	9140-0179	1		INDUCTOR RF-CH-MLD 22UH 10% .166DX.385LG	28480	9140-0179
A23L18	9100-3139	5	2	INDUCTOR 75UH 15% .5DX.875LG	28480	9100-3139
A23L19	9100-3139	5		INDUCTOR 75UH 15% .5DX.875LG	28480	9100-3139
A23L20	9140-0137	1		INDUCTOR RF-CH-MLD 1MH 5% .2DX.45LG Q=60	28480	9140-0137
A23Q1	1854-1074	2	7	TRANSISTOR NPN SI PD=200MW FT=30MHZ	28480	1854-1074
A23Q2	1855-0406	4	2	TRANSISTOR J-FET P-CHAN D-MODE SI	32293	1T110
A23Q3	1853-0314	9	1	TRANSISTOR PNP 2N2905A SI TO-39 PD=600MW	04713	2N2905A
A23Q4	1854-0810	2	3	TRANSISTOR NPN SI PD=625MW FT=200MHZ	28480	1854-0810
A23Q5	1855-0406	4		TRANSISTOR J-FET P-CHAN D-MODE SI	32293	1T110
A23Q6	1854-0637	1	1	TRANSISTOR NPN 2N2219A SI TO-5 PD=800MW	01295	2N2219A
A23Q7	1854-1074	2		TRANSISTOR NPN SI PD=200MW FT=30MHZ	28480	1854-1074
A23Q8	1854-1074	2		TRANSISTOR NPN SI PD=200MW FT=30MHZ	28480	1854-1074
A23Q9	1854-1074	2		TRANSISTOR NPN SI PD=200MW FT=30MHZ	28480	1854-1074
A23Q10	1855-0410	0	2	TRANSISTOR J-FET N-CHAN D-MODE TO-18 SI	28480	1855-0410
A23Q11	1854-1074	2		TRANSISTOR NPN SI PD=200MW FT=30MHZ	28480	1854-1074
A23Q12	1855-0609	9	3	TRANSISTOR J-FET N-CHAN TO-92 SI	28480	1855-0609
A23Q13	1855-0609	9		TRANSISTOR J-FET N-CHAN TO-92 SI	28480	1855-0609
A23Q14	1854-1074	2		TRANSISTOR NPN SI PD=200MW FT=30MHZ	28480	1854-1074
A23Q15	1854-1074	2		TRANSISTOR NPN SI PD=200MW FT=30MHZ	28480	1854-1074
A23Q16	1854-0597	2	1	TRANSISTOR NPN 2N5943 SI TO-39 PD=1W	04713	2N5943
A23Q17	1853-0293	3	1	TRANSISTOR PNP 2N5583 SI TO-39 PD=1W	04713	2N5583
A23Q18	1854-1073	1	4	TRANSISTOR NPN SI PD=600MW FT=6.5GHZ	28480	1854-1073
A23Q19	1854-1073	1		TRANSISTOR NPN SI PD=600MW FT=6.5GHZ	28480	1854-1073
A23Q20	1854-1073	1		TRANSISTOR NPN SI PD=600MW FT=6.5GHZ	28480	1854-1073
A23Q21	1854-1073	1		TRANSISTOR NPN SI PD=600MW FT=6.5GHZ	28480	1854-1073
A23Q22	1854-0810	2		TRANSISTOR NPN SI PD=625MW FT=200MHZ	28480	1854-0810
A23Q23	1855-0609	9		TRANSISTOR J-FET N-CHAN TO-92 SI	28480	1855-0609
A23Q24	1853-0018	0	1	TRANSISTOR PNP SI TO-72 PD=200MW FT=1GHZ	28480	1853-0018

See introduction to this section for ordering information.
 * Indicates factory selected value.

Table 6-3. Replaceable Parts (continued)

Reference Designator	HP Part Number	C D	Qty.	Description	Mfr Code	Mfr Part Number
A23Q25	1853-0459	3	1	TRANSISTOR PNP SI PD=625MW FT=200MHZ	28480	1853-0459
A23Q26	1854-0810	2		TRANSISTOR NPN SI PD=625MW FT=200MHZ	28480	1854-0810
A23Q27	1855-0410	0		TRANSISTOR J-FET N-CHAN D-MODE TO-18 SI	28480	1855-0410
A23R1	0698-3150	6	2	RESISTOR 2.37K 1% .125W F TC=0+-100	24546	C4-1/8-T0-2371-F
A23R2	0698-3150	6		RESISTOR 2.37K 1% .125W F TC=0+-100	24546	C4-1/8-T0-2371-F
A23R3	0698-3156	2	3	RESISTOR 14.7K 1% .125W F TC=0+-100	24546	C4-1/8-T0-1472-F
A23R4	0698-3156	2		RESISTOR 14.7K 1% .125W F TC=0+-100	24546	C4-1/8-T0-1472-F
A23R5	0698-3459	8	1	RESISTOR 383K 1% .125W F TC=0+-100	28480	0698-3459
A23R6	0757-0465	6	8	RESISTOR 100K 1% .125W F TC=0+-100	24546	C4-1/8-T0-1003-F
A23R7	0698-3160	8	2	RESISTOR 31.6K 1% .125W F TC=0+-100	24546	C4-1/8-T0-3162-F
A23R8	0698-3443	0	4	RESISTOR 287 1% .125W F TC=0+-100	24546	C4-1/8-T0-287R-F
A23R9	0757-0465	6		RESISTOR 100K 1% .125W F TC=0+-100	24546	C4-1/8-T0-1003-F
A23R10	0757-0465	6		RESISTOR 100K 1% .125W F TC=0+-100	24546	C4-1/8-T0-1003-F
A23R11	0757-0417	8	1	RESISTOR 562 1% .125W F TC=0+-100	24546	C4-1/8-T0-562R-F
A23R12	0757-0280	3	12	RESISTOR 1K 1% .125W F TC=0+-100	24546	C4-1/8-T0-1001-F
A23R13	0698-3160	8		RESISTOR 31.6K 1% .125W F TC=0+-100	24546	C4-1/8-T0-3162-F
A23R14	0757-0278	9	1	RESISTOR 1.78K 1% .125W F TC=0+-100	24546	C4-1/8-T0-1781-F
A23R15	0698-3155	1	7	RESISTOR 4.64K 1% .125W F TC=0+-100	24546	C4-1/8-T0-4641-F
A23R16	0698-3155	1		RESISTOR 4.64K 1% .125W F TC=0+-100	24546	C4-1/8-T0-4641-F
A23R17	0698-3155	1		RESISTOR 4.64K 1% .125W F TC=0+-100	24546	C4-1/8-T0-4641-F
A23R18	0698-3155	1		RESISTOR 4.64K 1% .125W F TC=0+-100	24546	C4-1/8-T0-4641-F
A23R19	0757-0465	6		RESISTOR 100K 1% .125W F TC=0+-100	24546	C4-1/8-T0-1003-F
A23R20	0698-4037	0	1	RESISTOR 46.4 1% .125W F TC=0+-100	24546	C4-1/8-T0-46R4-F
A23R21	0698-0083	8	1	RESISTOR 1.96K 1% .125W F TC=0+-100	24546	C4-1/8-T0-1961-F
A23R22	0757-0440	1	1	RESISTOR 7.5K 10%		
A23R23	0698-4479	4	1	RESISTOR 14K 1% .125W F TC=0+-100	24546	C4-1/8-T0-1402-F
A23R24	0757-0346	2	3	RESISTOR 10 1% .125W F TC=0+-100	24546	C4-1/8-T0-10R0-F
A23R25				NOT ASSIGNED		
A23R26	1810-0305	8	1	NETWORK-RES 9-SIP4.7K OHM X 8	28480	1810-0305
A23R27	0757-0280	3		RESISTOR 1K 1% .125W F TC=0+-100	24546	C4-1/8-T0-1001-F
A23R28	0757-0438	3	1	RESISTOR 5.11K 1% .125W F TC=0+-100	24546	C4-1/8-T0-5111-F
A23R29	0757-0465	6		RESISTOR 100K 1% .125W F TC=0+-100	24546	C4-1/8-T0-1003-F
A23R30	0757-0277	8	3	RESISTOR 49.9 1% .125W F TC=0+-100	24546	C4-1/8-T0-4992-F
A23R31	0757-0317	7	1	RESISTOR 1.33K 1% .125W F TC=0+-100	24546	C4-1/8-T0-1331-F
A23R32	0698-3443	0		RESISTOR 287 1% .125W F TC=0+-100	24546	C4-1/8-T0-287R-F
A23R33	0757-0280	3		RESISTOR 1K 1% .125W F TC=0+-100	24546	C4-1/8-T0-1001-F
A23R34	0757-0280	3		RESISTOR 1K 1% .125W F TC=0+-100	24546	C4-1/8-T0-1001-F
A23R35	0698-3430	5	7	RESISTOR 21.5 1% .125W F TC=0+-100	03888	PME55-1/8-T0-21R5-F
A23R36	0698-3430	5		RESISTOR 21.5 1% .125W F TC=0+-100	03888	PME55-1/8-T0-21R5-F
A23R37	0757-0442	9	4	RESISTOR 10K 1% .125W F TC=0+-100	24546	C4-1/8-T0-1002-F
A23R38	0757-0200	7	1	RESISTOR 5.62K 1% .125W F TC=0+-100	24546	C4-1/8-T0-5621-F
A23R39	0757-0395	1	1	RESISTOR 56.2 1% .125W F TC=0+-100	24546	C4-1/8-T0-56R2-F
A23R40	0757-0403	2	1	RESISTOR 121 1% .125W F TC=0+-100	24546	C4-1/8-T0-121R-F
A23R41	0757-0280	3		RESISTOR 1K 1% .125W F TC=0+-100	24546	C4-1/8-T0-1001-F
A23R42	0757-0280	3		RESISTOR 1K 1% .125W F TC=0+-100	24546	C4-1/8-T0-1001-F
A23R43	0698-8827	4	1	RESISTOR 1M 1% .125W F TC=0+-100	28480	0698-8827
A23R44	0757-0280	3		RESISTOR 1K 1% .125W F TC=0+-100	24546	C4-1/8-T0-1001-F
A23R45	0757-0280	3		RESISTOR 1K 1% .125W F TC=0+-100	24546	C4-1/8-T0-1001-F

See introduction to this section for ordering information.
 * Indicates factory selected value.

Table 6-3. Replaceable Parts (continued)

Reference Designator	HP Part Number	C D	Qty.	Description	Mfr Code	Mfr Part Number
A23R46	0698-3226	7	1	RESISTOR 6.49K 1% .125W F TC=0+-100	24546	C4-1/8-T0-6491-F
A23R47	0757-0277	8		RESISTOR 49.9 1% .125W F TC=0+-100	24546	C4-1/8-T0-4992-F
A23R48	0757-0280	3		RESISTOR 1K 1% .125W F TC=0+-100	24546	C4-1/8-T0-1001-F
A23R49	0757-0280	3		RESISTOR 1K 1% .125W F TC=0+-100	24546	C4-1/8-T0-1001-F
A23R50	0757-0346	2		RESISTOR 10 1% .125W F TC=0+-100	24546	C4-1/8-T0-10R0-F
A23R51	0757-0346	2		RESISTOR 10 1% .125W F TC=0+-100	24546	C4-1/8-T0-10R0-F
A23R52	0757-0401	0	12	RESISTOR 100 1% .125W F TC=0+-100	24546	C4-1/8-T0-101-F
A23R53	0757-0401	0		RESISTOR 100 1% .125W F TC=0+-100	24546	C4-1/8-T0-101-F
A23R54	0757-0394	0	2	RESISTOR 51.1 1% .125W F TC=0+-100	24546	C4-1/8-T0-51R1-F
A23R55	0757-0394	0		RESISTOR 51.1 1% .125W F TC=0+-100	24546	C4-1/8-T0-51R1-F
A23R56				NOT ASSIGNED		
A23R57	0698-3445	2	1	RESISTOR 348 1% .125W F TC=0+-100	24546	C4-1/8-T0-348R-F
A23R58	0757-0401	0		RESISTOR 100 1% .125W F TC=0+-100	24546	C4-1/8-T0-101-F
A23R59	0757-0401	0		RESISTOR 100 1% .125W F TC=0+-100	24546	C4-1/8-T0-101-F
A23R60	0757-0401	0		RESISTOR 100 1% .125W F TC=0+-100	24546	C4-1/8-T0-101-F
A23R61	0757-0401	0		RESISTOR 100 1% .125W F TC=0+-100	24546	C4-1/8-T0-101-F
A23R62	0698-3155	1		RESISTOR 4.64K 1% .125W F TC=0+-100	24546	C4-1/8-T0-4641-F
A23R63	0757-0180	2	1	RESISTOR 31.6 1% .125W F TC=0+-100	28480	0757-0180
A23R64	0757-0277	8		RESISTOR 49.9 1% .125W F TC=0+-100	24546	C4-1/8-T0-4992-F
A23R65	0757-0401	0		RESISTOR 100 1% .125W F TC=0+-100	24546	C4-1/8-T0-101-F
A23R66	0757-0422	5	1	RESISTOR 909 1% .125W F TC=0+-100	24546	C4-1/8-T0-909R-F
A23R67	0698-3430	5		RESISTOR 21.5 1% .125W F TC=0+-100	03888	PME55-1/8-T0-21R5-F
A23R68	0757-0416	7	1	RESISTOR 511 1% .125W F TC=0+-100	24546	C4-1/8-T0-511R-F
A23R69	0698-3262	1	1	RESISTOR 40.2 1% .125W F TC=0+-100	24546	C4-1/8-T0-4022-F
A23R70	0698-3447	4	4	RESISTOR 422 1% .125W F TC=0+-100	24546	C4-1/8-T0-422R-F
A23R71	0698-3447	4		RESISTOR 422 1% .125W F TC=0+-100	24546	C4-1/8-T0-422R-F
A23R72	0757-0465	6		RESISTOR 100K 1% .125W F TC=0+-100	24546	C4-1/8-T0-1003-F
A23R73	0757-0465	6		RESISTOR 100K 1% .125W F TC=0+-100	24546	C4-1/8-T0-1003-F
A23R74	0757-0280	3		RESISTOR 1K 1% .125W F TC=0+-100	24546	C4-1/8-T0-1001-F
A23R75	0757-0280	3		RESISTOR 1K 1% .125W F TC=0+-100	24546	C4-1/8-T0-1001-F
A23R76	0757-0401	0		RESISTOR 100 1% .125W F TC=0+-100	24546	C4-1/8-T0-101-F
A23R77	0757-0401	0		RESISTOR 100 1% .125W F TC=0+-100	24546	C4-1/8-T0-101-F
A23R78	0757-0401	0		RESISTOR 100 1% .125W F TC=0+-100	24546	C4-1/8-T0-101-F
A23R79	0757-0401	0		RESISTOR 100 1% .125W F TC=0+-100	24546	C4-1/8-T0-101-F
A23R80	0757-0401	0		RESISTOR 100 1% .125W F TC=0+-100	24546	C4-1/8-T0-101-F
A23R81	0757-0279	0	2	RESISTOR 3.16K 1% .125W F TC=0+-100	24546	C4-1/8-T0-3161-F
A23R82	0757-0420	3	1	RESISTOR 750 1% .125W F TC=0+-100	24546	C4-1/8-T0-751-F
A23R83	0764-0016	8	1	RESISTOR 1K 5% 2W MO TC=0+-200	28480	0764-0016
A23R84	0757-0274	5	1	RESISTOR 1.21K 1% .125W F TC=0+-100	24546	C4-1/8-T0-1211-F
A23R85	0698-4421	6	1	RESISTOR 249 1% .125W F TC=0+-100	24546	C4-1/8-T0-249R-F
A23R86	0698-3155	1		RESISTOR 4.64K 1% .125W F TC=0+-100	24546	C4-1/8-T0-4641-F
A23R87	0698-3156	2		RESISTOR 14.7K 1% .125W F TC=0+-100	24546	C4-1/8-T0-1472-F
A23R88	0698-3155	1		RESISTOR 4.64K 1% .125W F TC=0+-100	24546	C4-1/8-T0-4641-F
A23R89	0757-0279	0		RESISTOR 3.16K 1% .125W F TC=0+-100	24546	C4-1/8-T0-3161-F
A23R90	0698-3447	4		RESISTOR 422 1% .125W F TC=0+-100	24546	C4-1/8-T0-422R-F
A23R91	0698-3447	4		RESISTOR 422 1% .125W F TC=0+-100	24546	C4-1/8-T0-422R-F
A23R92	0698-3154	0	1	RESISTOR 4.22K 1% .125W F TC=0+-100	24546	C4-1/8-T0-4221-F
A23R93	2100-3212	8	1	RESISTOR-TRMR 200 10% C TOP-ADJ 1-TRN	28480	2100-3212
A23R94	0698-3430	5		RESISTOR 21.5 1% .125W F TC=0+-100	03888	PME55-1/8-T0-21R5-F

See introduction to this section for ordering information.
* Indicates factory selected value.

Table 6-3. Replaceable Parts (continued)

Reference Designator	HP Part Number	C D	Qty.	Description	Mfr Code	Mfr Part Number
A23R95	0698-3430		5	RESISTOR 21.5 1% .125W F TC=0+-100	03888	PME55-1/8-T0-21R5-F
A23R96	0757-0465		6	RESISTOR 100K 1% .125W F TC=0+-100	24546	C4-1/8-T0-1003-F
A23R97	0698-8958		2	RESISTOR 511K 1% .125W F TC=0+-100	28480	0698-8958
A23R98				NOT ASSIGNED		
A23R99				NOT ASSIGNED		
A23R100	0698-3430		5	RESISTOR 21.5 1% .125W F TC=0+-100	03888	PME55-1/8-T0-21R5-F
A23R101	0698-3430		5	RESISTOR 21.5 1% .125W F TC=0+-100	03888	PME55-1/8-T0-21R5-F
A23R102	0757-0442		9	RESISTOR 10K 1% .125W F TC=0+-100	24546	C4-1/8-T0-1002-F
A23R103	0757-0442		9	RESISTOR 10K 1% .125W F TC=0+-100	24546	C4-1/8-T0-1002-F
A23R104	0757-0442		9	RESISTOR 10K 1% .125W F TC=0+-100	24546	C4-1/8-T0-1002-F
A23R105	0698-3443		0	RESISTOR 287 1% .125W F TC=0+-100	24546	C4-1/8-T0-287R-F
A23R106	0757-0294		9	RESISTOR 17.8 1% .125W F TC=0+-100	19701	MF4C1/8-T0-17R8-F
A23R107	0698-3443		0	RESISTOR 287 1% .125W F TC=0+-100	24546	C4-1/8-T0-287R-F
A23T1	9100-4452		7	PULSE TRANSE 11201	28480	9100-4452
A23T2	9100-0879		4	XFMR-PLS 113B21	28480	9100-0879
A23U1	1826-0138		8	IC COMPARATOR GP QUAD 14-DIP-P PKG	01295	LM339N
A23U2	1826-0138		8	IC COMPARATOR GP QUAD 14-DIP-P PKG	01295	LM339N
A23U3	1826-0081		0	IC OP AMP WB TO-99 PKG	27014	LM318H
A23U4	1820-2757		9	IC FF TTL ALS D-TYPE POS-EDGE-TRIG OCTL	01295	SN74ALS574N
A23U5	1826-0412		1	IC COMPARATOR PRCN DUAL 8-DIP-P PKG	27014	LM393N
A23U6	1820-1433		6	IC SHF-RGTR TTL LS R-S SERIAL-IN PRL-OUT	01295	SN74LS164N
A23U7	1820-1433		6	IC SHF-RGTR TTL LS R-S SERIAL-IN PRL-OUT	01295	SN74LS164N
A23U8	1826-0276		5	IC 78L05A V RGLTR TO-92	04713	MC78L05ACP
A23U9	1826-1148		2	IC OP AMP PRCN 8-TO-99 PKG	28480	1826-1148
A23U10	1826-0221		0	IC V RGLTR TO-220	04713	MC7912CT
A23U11	1826-0147		9	IC 7812 V RGLTR TO-220	04713	MC7812CP

See introduction to this section for ordering information.
 * Indicates factory selected value.

Table 6-3. Replaceable Parts (continued)

Reference Designator	HP Part Number	C D	Qty.	Description	Mfr Code	Mfr Part Number
A24	04194-66524	8	1	OUTPUT AMPLIFIER BOARD ASSEMBLY FOR OPTION 350 UNITS	28480	04194-66524
A24A1	04194-66553	3	1	PWR SPLTR BD ASSY	28480	04194-66553
A24C1	0160-4835	7	3	CAPACITOR-FXD .1UF +-10% 50VDC CER	28480	0160-4835
A24C2	0180-3469	3	8	CAPACITOR-FXD 100UF +-20% 25VDC AL	28480	0180-3469
A24C3	0180-3469	3		CAPACITOR-FXD 100UF +-20% 25VDC AL	28480	0180-3469
A24C4	0160-4835	7		CAPACITOR-FXD .1UF +-10% 50VDC CER	28480	0160-4835
A24C5	0160-4835	7		CAPACITOR-FXD .1UF +-10% 50VDC CER	28480	0160-4835
A24C6	0180-3469	3		CAPACITOR-FXD 100UF +-20% 25VDC AL	28480	0180-3469
A24C7	0180-3469	3		CAPACITOR-FXD 100UF +-20% 25VDC AL	28480	0180-3469
A24C8	0180-3469	3		CAPACITOR-FXD 100UF +-20% 25VDC AL	28480	0180-3469
A24C9	0180-3469	3		CAPACITOR-FXD 100UF +-20% 25VDC AL	28480	0180-3469
A24C10	0160-4832	4	30	CAPACITOR-FXD .01UF +-10% 100VDC CER	28480	0160-4832
A24C11	0180-3593	4	4	CAPACITOR-FXD 330UF +-20% 25VDC AL	28480	0180-3593
A24C12	0180-3363	6	25	CAPACITOR-FXD 22UF +-20% 25VDC AL	28480	0180-3363
A24C13	0180-3363	6		CAPACITOR-FXD 22UF +-20% 25VDC AL	28480	0180-3363
A24C14	0160-4832	4		CAPACITOR-FXD .01UF +-10% 100VDC CER	28480	0160-4832
A24C15	0160-2237	9	2	CAPACITOR-FXD 1.2PF +- .25PF 500VDC CER	28480	0160-2237
A24C16	0180-3363	6		CAPACITOR-FXD 22UF +-20% 25VDC AL	28480	0180-3363
A24C17	0160-4832	4		CAPACITOR-FXD .01UF +-10% 100VDC CER	28480	0160-4832
A24C18	0180-3363	6		CAPACITOR-FXD 22UF +-20% 25VDC AL	28480	0180-3363
A24C19	0160-4786	7	2	CAPACITOR-FXD 27PF +-5% 100VDC CER 0+-30	28480	0160-4786
A24C20	0160-4805	1	1	CAPACITOR-FXD 47PF +-5% 100VDC CER 0+-30	28480	0160-4805
A24C21	0160-4786	7		CAPACITOR-FXD 27PF +-5% 100VDC CER 0+-30	28480	0160-4786
A24C22	0160-4801	7	3	CAPACITOR-FXD 100PF +-5% 100VDC CER	28480	0160-4801
A24C23	0160-4803	9	2	CAPACITOR-FXD 68PF +-5% 100VDC CER 0+-30	28480	0160-4803
A24C24	0160-4800	6	1	CAPACITOR-FXD 120PF +-5% 100VDC CER	28480	0160-4800
A24C25	0160-4803	9		CAPACITOR-FXD 68PF +-5% 100VDC CER 0+-30	28480	0160-4803
A24C26	0180-3363	6		CAPACITOR-FXD 22UF +-20% 25VDC AL	28480	0180-3363
A24C27	0160-4832	4		CAPACITOR-FXD .01UF +-10% 100VDC CER	28480	0160-4832
A24C28	0180-3363	6		CAPACITOR-FXD 22UF +-20% 25VDC AL	28480	0180-3363
A24C29	0180-3363	6		CAPACITOR-FXD 22UF +-20% 25VDC AL	28480	0180-3363
A24C30	0160-2237	9		CAPACITOR-FXD 1.2PF +- .25PF 500VDC CER	28480	0160-2237
A24C31	0160-4832	4		CAPACITOR-FXD .01UF +-10% 100VDC CER	28480	0160-4832
A24C32	0180-3363	6		CAPACITOR-FXD 22UF +-20% 25VDC AL	28480	0180-3363
A24C33	0180-3363	6		CAPACITOR-FXD 22UF +-20% 25VDC AL	28480	0180-3363
A24C34	0160-4832	4		CAPACITOR-FXD .01UF +-10% 100VDC CER	28480	0160-4832
A24C35	0180-3363	6		CAPACITOR-FXD 22UF +-20% 25VDC AL	28480	0180-3363
A24C36	0180-3363	6		CAPACITOR-FXD 22UF +-20% 25VDC AL	28480	0180-3363
A24C37	0160-4832	4		CAPACITOR-FXD .01UF +-10% 100VDC CER	28480	0160-4832
A24C38	0180-3363	6		CAPACITOR-FXD 22UF +-20% 25VDC AL	28480	0180-3363
A24C39	0180-3363	6		CAPACITOR-FXD 22UF +-20% 25VDC AL	28480	0180-3363
A24C40	0180-3363	6		CAPACITOR-FXD 22UF +-20% 25VDC AL	28480	0180-3363
A24C41	0160-4832	4		CAPACITOR-FXD .01UF +-10% 100VDC CER	28480	0160-4832
A24C42	0160-4832	4		CAPACITOR-FXD 0.01UF +-10% 100VDC CER	28480	0160-4832
A24C43	0160-4832	4		CAPACITOR-FXD .01UF +-10% 100VDC CER	28480	0160-4832
A24C44	0180-3363	6		CAPACITOR-FXD 22UF +-20% 25VDC AL	28480	0180-3363
A24C45	0180-3363	6		CAPACITOR-FXD 22UF +-20% 25VDC AL	28480	0180-3363

See introduction to this section for ordering information.
* Indicates factory selected value.

Table 6-3. Replaceable Parts (continued)

Reference Designator	HP Part Number	C D	Qty.	Description	Mfr Code	Mfr Part Number
A24C46	0180-3363	6		CAPACITOR-FXD 22UF +-20% 25VDC AL	28480	0180-3363
A24C47	0180-3363	6		CAPACITOR-FXD 22UF +-20% 25VDC AL	28480	0180-3363
A24C48	0180-3363	6		CAPACITOR-FXD 22UF +-20% 25VDC AL	28480	0180-3363
A24C49	0160-4832	4		CAPACITOR-FXD .01UF +-10% 100VDC CER	28480	0160-4832
A24C50	0160-4832	4		CAPACITOR-FXD .01UF +-10% 100VDC CER	28480	0160-4832
A24C51	0180-3596	7	3	CAPACITOR-FXD 100UF +-20% 100VDC AL	28480	0180-3596
A24C52	0160-4832	4		CAPACITOR-FXD .01UF +-10% 100VDC CER	28480	0160-4832
A24C53	0160-4832	4		CAPACITOR-FXD .01UF +-10% 100VDC CER	28480	0160-4832
A24C54	0160-4832	4		CAPACITOR-FXD .01UF +-10% 100VDC CER	28480	0160-4832
A24C55	0160-4832	4		CAPACITOR-FXD .01UF +-10% 100VDC CER	28480	0160-4832
A24C56	0180-3469	3		CAPACITOR-FXD 100UF +-20% 25VDC AL	28480	0180-3469
A24C57	0180-3593	4		CAPACITOR-FXD 330UF +-20% 25VDC AL	28480	0180-3593
A24C58	0180-3469	3		CAPACITOR-FXD 100UF +-20% 25VDC AL	28480	0180-3469
A24C59	0160-4832	4		CAPACITOR-FXD .01UF +-10% 100VDC CER	28480	0160-4832
A24C60	0160-4801	7		CAPACITOR-FXD 100PF +-5% 100VDC CER	28480	0160-4801
A24C61	0160-4832	4		CAPACITOR-FXD .01UF +-10% 100VDC CER	28480	0160-4832
A24C62	0160-4832	4		CAPACITOR-FXD .01UF +-10% 100VDC CER	28480	0160-4832
A24C63	0160-4832	4		CAPACITOR-FXD .01UF +-10% 100VDC CER	28480	0160-4832
A24C64	0160-4808	4	2	CAPACITOR-FXD 470PF +-5% 100VDC CER	28480	0160-4808
A24C65	0180-3363	6		CAPACITOR-FXD 22UF +-20% 25VDC AL	28480	0180-3363
A24C66	0180-3596	7		CAPACITOR-FXD 100UF +-20% 100VDC AL	28480	0180-3596
A24C67	0180-3431	9	2	CAPACITOR-FXD 220UF +-20% 10VDC AL	28480	0180-3431
A24C68	0180-3431	9		CAPACITOR-FXD 220UF +-20% 10VDC AL	28480	0180-3431
A24C69	0160-4832	4		CAPACITOR-FXD .01UF +-10% 100VDC CER	28480	0160-4832
A24C70	0180-3593	4		CAPACITOR-FXD 330UF +-20% 25VDC AL	28480	0180-3593
A24C71	0180-3593	4		CAPACITOR-FXD 330UF +-20% 25VDC AL	28480	0180-3593
A24C72	0180-3363	6		CAPACITOR-FXD 22UF +-20% 25VDC AL	28480	0180-3363
A24C73	0180-3596	7		CAPACITOR-FXD 100UF +-20% 100VDC AL	28480	0180-3596
A24C74	0180-3363	6		CAPACITOR-FXD 22UF +-20% 25VDC AL	28480	0180-3363
A24C75	0180-3363	6		CAPACITOR-FXD 22UF +-20% 25VDC AL	28480	0180-3363
A24C76	0160-4808	4		CAPACITOR-FXD 470PF +-5% 100VDC CER	28480	0160-4808
A24C77	0160-4832	4		CAPACITOR-FXD .01UF +-10% 100VDC CER	28480	0160-4832
A24C78	0160-4832	4		CAPACITOR-FXD .01UF +-10% 100VDC CER	28480	0160-4832
A24C79	0160-4832	4		CAPACITOR-FXD .01UF +-10% 100VDC CER	28480	0160-4832
A24C80	0160-4832	4		CAPACITOR-FXD .01UF +-10% 100VDC CER	28480	0160-4832
A24C81	0180-1075	3	1	CAPACITOR-FXD 2200 UF 16VDC AL	28480	0180-1075
A24C82	0160-4832	4		CAPACITOR-FXD .01UF +-10% 100VDC CER	28480	0160-4832
A24C83	0160-4832	4		CAPACITOR-FXD .01UF +-10% 100VDC CER	28480	0160-4832
A24C84	0160-6342	5	1	CAPACITOR 1U 100V FILM	28480	0160-6342
A24C85	0180-1085	5	1	CAPACITOR-FXD 4.7UF 16VDC TA	28480	0180-1085
A24C86	0160-4832	4		CAPACITOR-FXD .01UF +-10% 100VDC CER	28480	0160-4832
A24C87	0180-3363	6		CAPACITOR-FXD 22UF +-20% 25VDC AL	28480	0180-3363
A24C88	0180-3363	6		CAPACITOR-FXD 22UF +-20% 25VDC AL	28480	0180-3363
A24C89	0160-4832	4		CAPACITOR-FXD .01UF +-10% 100VDC CER	28480	0160-4832
A24C90	0160-4832	4		CAPACITOR-FXD .01UF +-10% 100VDC CER	28480	0160-4832
A24C91	0160-4801	7		CAPACITOR-FXD 100PF +-5% 100VDC CER	28480	0160-4801
A24CR1	1901-0050	3	32	DIODE-SWITCHING 80V 200MA 2NS DO-35	28480	1901-0050
A24CR2	1902-0692	1	1	DIODE-ZNR 6.3V 1% DO-7 PD=-.4W TC=+.001%	28480	1902-0692

See introduction to this section for ordering information.
 * Indicates factory selected value.

Table 6-3. Replaceable Parts (continued)

Reference Designator	HP Part Number	C D	Qty.	Description	Mfr Code	Mfr Part Number
A24CR3	1902-0950	4	1	DIODE-ZNR 4.7V 5% DO-35 PD=.4W TC=+.025%	28480	1902-0950
A24CR4	1901-0050	3		DIODE-SWITCHING 80V 200MA 2NS DO-35	28480	1901-0050
A24CR5	1901-0050	3		DIODE-SWITCHING 80V 200MA 2NS DO-35	28480	1901-0050
A24CR6	1901-0050	3		DIODE-SWITCHING 80V 200MA 2NS DO-35	28480	1901-0050
A24CR7	1901-0050	3		DIODE-SWITCHING 80V 200MA 2NS DO-35	28480	1901-0050
A24CR8	1901-0050	3		DIODE-SWITCHING 80V 200MA 2NS DO-35	28480	1901-0050
A24CR9	1901-0050	3		DIODE-SWITCHING 80V 200MA 2NS DO-35	28480	1901-0050
A24CR10	1901-0050	3		DIODE-SWITCHING 80V 200MA 2NS DO-35	28480	1901-0050
A24CR11	1901-0050	3		DIODE-SWITCHING 80V 200MA 2NS DO-35	28480	1901-0050
A24CR12	1901-0050	3		DIODE-SWITCHING 80V 200MA 2NS DO-35	28480	1901-0050
A24CR13	1901-0050	3		DIODE-SWITCHING 80V 200MA 2NS DO-35	28480	1901-0050
A24CR14	1901-0050	3		DIODE-SWITCHING 80V 200MA 2NS DO-35	28480	1901-0050
A24CR15	1901-0050	3		DIODE-SWITCHING 80V 200MA 2NS DO-35	28480	1901-0050
A24CR16	1901-0050	3		DIODE-SWITCHING 80V 200MA 2NS DO-35	28480	1901-0050
A24CR17	1901-0050	3		DIODE-SWITCHING 80V 200MA 2NS DO-35	28480	1901-0050
A24CR18	1901-0050	3		DIODE-SWITCHING 80V 200MA 2NS DO-35	28480	1901-0050
A24CR19	1901-0050	3		DIODE-SWITCHING 80V 200MA 2NS DO-35	28480	1901-0050
A24CR20	1901-0050	3		DIODE-SWITCHING 80V 200MA 2NS DO-35	28480	1901-0050
A24CR21	1901-0050	3		DIODE-SWITCHING 80V 200MA 2NS DO-35	28480	1901-0050
A24CR22	1901-0050	3		DIODE-SWITCHING 80V 200MA 2NS DO-35	28480	1901-0050
A24CR23	1901-0050	3		DIODE-SWITCHING 80V 200MA 2NS DO-35	28480	1901-0050
A24CR24	1901-0050	3		DIODE-SWITCHING 80V 200MA 2NS DO-35	28480	1901-0050
A24CR25	1901-0050	3		DIODE-SWITCHING 80V 200MA 2NS DO-35	28480	1901-0050
A24CR26	1901-0050	3		DIODE-SWITCHING 80V 200MA 2NS DO-35	28480	1901-0050
A24CR27	1901-0050	3		DIODE-SWITCHING 80V 200MA 2NS DO-35	28480	1901-0050
A24CR28				DIODE-SWITCHING 80V 200MA 2NS DO-35		
A24CR29	1901-0050	3		NOT ASSIGNED	28480	1901-0050
A24CR30	1902-0961	7	2	DIODE-ZNR 13V 5% DO-35 PD=.4W TC=+.082%	28480	1902-0961
A24CR31	1902-0961	7		DIODE-ZNR 13V 5% DO-35 PD=.4W TC=+.082%	28480	1902-0961
A24CR32	1901-0050	3		DIODE-SWITCHING 80V 200MA 2NS DO-35	28480	1901-0050
A24CR33	1901-0050	3		DIODE-SWITCHING 80V 200MA 2NS DO-35	28480	1901-0050
A24CR34	1901-0050	3		DIODE-SWITCHING 80V 200MA 2NS DO-35	28480	1901-0050
A24CR35	1901-0050	3		DIODE-SWITCHING 80V 200MA 2NS DO-35	28480	1901-0050
A24CR36	1901-0050	3		DIODE-SWITCHING 80V 200MA 2NS DO-35	28480	1901-0050
A24CR37	1901-0050	3		DIODE-SWITCHING 80V 200MA 2NS DO-35	28480	1901-0050
A24J1	1200-0541	1	1	SOCKET-IC 24-CONT DIP DIP-SLDR	28480	1200-0541
A24J2	1250-0257	1	2	CONNECTOR-RF SMB M PC 50-OHM	28480	1250-0257
A24J3	0360-0124	3	6	CONNECTOR-SGL CONT PIN .04-IN-BSC-SZ RND	28480	0360-0124
A24J4	0360-0124	3		CONNECTOR-SGL CONT PIN .04-IN-BSC-SZ RND	28480	0360-0124
A24J5	0360-0124	3		CONNECTOR-SGL CONT PIN .04-IN-BSC-SZ RND	28480	0360-0124
A24J6	0360-0124	3		CONNECTOR-SGL CONT PIN .04-IN-BSC-SZ RND	28480	0360-0124
A24J7	0360-0124	3		CONNECTOR-SGL CONT PIN .04-IN-BSC-SZ RND	28480	0360-0124
A24J8	0360-0124	3		CONNECTOR-SGL CONT PIN .04-IN-BSC-SZ RND	28480	0360-0124
A24J9	1250-0257	1		CONNECTOR-RF SMB M PC 50-OHM	28480	1250-0257
A24K1	0490-1485	6	7	RELAY SW	28480	RY5W-OH-K
A24K2	0490-1485	6		RELAY SW	28480	RY5W-OH-K
A24K3	0490-1485	6		RELAY SW	28480	RY5W-OH-K
A24K4	0490-1485	6		RELAY SW	28480	RY5W-OH-K
A24K5	0490-1485	6		RELAY SW	28480	RY5W-OH-K

See introduction to this section for ordering information.
 * Indicates factory selected value.

Table 6-3. Replaceable Parts (continued)

Reference Designator	HP Part Number	C D	Qty.	Description	Mfr Code	Mfr Part Number
A24K6	0490-1485	6		RELAY SW	28480	RY5W-OH-K
A24K7	0490-1485	6		RELAY SW	28480	RY5W-OH-K
A24L1	9140-0114	4	3	INDUCTOR RF-CH-MLD 10UH 10% .166DX.385LG	28480	9140-0114
A24L2	9140-0114	4		INDUCTOR RF-CH-MLD 10UH 10% .166DX.385LG	28480	9140-0114
A24L3	9140-0114	4		INDUCTOR RF-CH-MLD 10UH 10% .166DX.385LG	28480	9140-0114
A24L4	9100-2259	8	16	INDUCTOR RF-CH-MLD 1.5UH 10% .105DX.26LG	28480	9100-2259
A24L5	9100-2259	8		INDUCTOR RF-CH-MLD 1.5UH 10% .105DX.26LG	28480	9100-2259
A24L6	9100-2247	4	4	INDUCTOR RF-CH-MLD 100NH 10% .105DX.26LG	28480	9100-2247
A24L7	9100-2247	4		INDUCTOR RF-CH-MLD 100NH 10% .105DX.26LG	28480	9100-2247
A24L8	9100-2251	0	2	INDUCTOR RF-CH-MLD 220NH 10% .105DX.26LG	28480	9100-2251
A24L9	9100-2251	0		INDUCTOR RF-CH-MLD 220NH 10% .105DX.26LG	28480	9100-2251
A24L10	9100-2259	8		INDUCTOR RF-CH-MLD 1.5UH 10% .105DX.26LG	28480	9100-2259
A24L11	9100-2259	8		INDUCTOR RF-CH-MLD 1.5UH 10% .105DX.26LG	28480	9100-2259
A24L12	9100-2259	8		INDUCTOR RF-CH-MLD 1.5UH 10% .105DX.26LG	28480	9100-2259
A24L13	9100-2259	8		INDUCTOR RF-CH-MLD 1.5UH 10% .105DX.26LG	28480	9100-2259
A24L14	9100-2259	8		INDUCTOR RF-CH-MLD 1.5UH 10% .105DX.26LG	28480	9100-2259
A24L15	9100-2259	8		INDUCTOR RF-CH-MLD 1.5UH 10% .105DX.26LG	28480	9100-2259
A24L16	9100-2259	8		INDUCTOR RF-CH-MLD 1.5UH 10% .105DX.26LG	28480	9100-2259
A24L17	9100-2259	8		INDUCTOR RF-CH-MLD 1.5UH 10% .105DX.26LG	28480	9100-2259
A24L18	9100-2259	8		INDUCTOR RF-CH-MLD 1.5UH 10% .105DX.26LG	28480	9100-2259
A24L19	9100-2259	8		INDUCTOR RF-CH-MLD 1.5UH 10% .105DX.26LG	28480	9100-2259
A24L20	9100-2259	8		INDUCTOR RF-CH-MLD 1.5UH 10% .105DX.26LG	28480	9100-2259
A24L21	9100-2259	8		INDUCTOR RF-CH-MLD 1.5UH 10% .105DX.26LG	28480	9100-2259
A24L22	9100-2247	4		INDUCTOR RF-CH-MLD 100NH 10% .105DX.26LG	28480	9100-2247
A24L23	9100-2247	4		INDUCTOR RF-CH-MLD 100NH 10% .105DX.26LG	28480	9100-2247
A24L24	9100-2259	8		INDUCTOR RF-CH-MLD 1.5UH 10% .105DX.26LG	28480	9100-2259
A24L25	9100-2259	8		INDUCTOR RF-CH-MLD 1.5UH 10% .105DX.26LG	28480	9100-2259
A24L26	9100-1654	5	2	INDUCTOR RF-CH-MLD 1.1MH 5% .23DX.57LG	28480	9100-1654
A24L27	9100-1654	5		INDUCTOR RF-CH-MLD 1.1MH 5% .23DX.57LG	28480	9100-1654
A24L28	9100-0368	6	1	INDUCTOR RF-CH-MLD 330NH 10% .105DX.26LG	28480	9100-0368
A24Q1	1853-0232	0	3	TRANSISTOR PNP SI TO-39 PD=1W FT=200MHZ	28480	1853-0232
A24Q2	1853-0232	0		TRANSISTOR PNP SI TO-39 PD=1W FT=200MHZ	28480	1853-0232
A24Q3	1853-0232	0		TRANSISTOR PNP SI TO-39 PD=1W FT=200MHZ	28480	1853-0232
A24Q4	1854-0474	4	4	TRANSISTOR NPN SI PD=310MW FT=100MHZ	04713	2N5551
A24Q5	1854-0474	4		TRANSISTOR NPN SI PD=310MW FT=100MHZ	04713	2N5551
A24Q6	1853-0080	6	3	TRANSISTOR PNP SI PD=300MW FT=30MHZ	28480	1853-0080
A24Q7	1854-0474	4		TRANSISTOR NPN SI PD=310MW FT=100MHZ	04713	2N5551
A24Q8	1854-0271	9	4	TRANSISTOR NPN SI TO-39 PD=1W FT=150MHZ	28480	1854-0271
A24Q9	1854-0637	1	1	TRANSISTOR NPN 2N2219A SI TO-5 PD=800MW	01295	2N2219A
A24Q10	1853-0459	3	1	TRANSISTOR PNP SI PD=625MW FT=200MHZ	28480	1853-0459
A24Q11	1854-0597	2	2	TRANSISTOR NPN 2N5943 SI TO-39 PD=1W	04713	2N5943
A24Q12	1854-0271	9		TRANSISTOR NPN SI TO-39 PD=1W FT=150MHZ	28480	1854-0271
A24Q13	1854-0271	9		TRANSISTOR NPN SI TO-39 PD=1W FT=150MHZ	28480	1854-0271
A24Q14	1854-0271	9		TRANSISTOR NPN SI TO-39 PD=1W FT=150MHZ	28480	1854-0271
A24Q15	1853-0080	6		TRANSISTOR PNP SI PD=300MW FT=30MHZ	28480	1853-0080
A24Q16	1853-0080	6		TRANSISTOR PNP SI PD=300MW FT=30MHZ	28480	1853-0080
A24Q17	1854-0474	4		TRANSISTOR NPN SI PD=310MW FT=100MHZ	04713	2N5551
A24Q18	1854-0597	2		TRANSISTOR NPN 2N5943 SI TO-39 PD=1W	04713	2N5943
A24R1	1810-0269	3	1	NETWORK-RES 9-SIP10.0K OHM X 8	28480	1810-0269

See introduction to this section for ordering information.
 * Indicates factory selected value.

Table 6-3. Replaceable Parts (continued)

Reference Designator	HP Part Number	C D	Qty.	Description	Mfr Code	Mfr Part Number
A24R2	2100-0554	5	1	RESISTOR-TRMR 500 10% C TOP-ADJ 1-TRN	28480	2100-0554
A24R3	0757-0273	4	1	RESISTOR 3.01K 1% .125W F TC=0+-100	24546	C4-1/8-T0-3011-F
A24R4	0698-6360	6	3	RESISTOR 10K .1% .125W F TC=0+-25	28480	0698-6360
A24R5	0757-0420	3	1	RESISTOR 750 1% .125W F TC=0+-100	24546	C4-1/8-T0-751-F
A24R6	0757-0401	0	9	RESISTOR 100 1% .125W F TC=0+-100	24546	C4-1/8-T0-101-F
A24R7	0698-6360	6		RESISTOR 10K .1% .125W F TC=0+-25	28480	0698-6360
A24R8	2100-0568	1	1	RESISTOR-TRMR 100 10% C TOP-ADJ 1-TRN	28480	2100-0568
A24R9	0698-6360	6		RESISTOR 10K .1% .125W F TC=0+-25	28480	0698-6360
A24R10	0757-0394	0	2	RESISTOR 51.1 1% .125W F TC=0+-100	24546	C4-1/8-T0-51R1-F
A24R11	0699-1701	1	4	RESISTOR 150.5 .1% .125W F TC=0+-50	28480	0699-1701
A24R12	0699-1670	3	2	RESISTOR 37.35 .1% .125W F TC=0+-50	28480	0699-1670
A24R13	0699-1701	1		RESISTOR 150.5 .1% .125W F TC=0+-50	28480	0699-1701
A24R14	0757-0379	1	1	RESISTOR 12.1 1% .125W F TC=0+-100	19701	MF4C1/8-T0-12R1-F
A24R15	0757-0280	3	6	RESISTOR 1K 1% .125W F TC=0+-100	24546	C4-1/8-T0-1001-F
A24R16	0699-1701	1		RESISTOR 150.5 .1% .125W F TC=0+-50	28480	0699-1701
A24R17	0699-1670	3		RESISTOR 37.35 .1% .125W F TC=0+-50	28480	0699-1670
A24R18	0699-1701	1		RESISTOR 150.5 .1% .125W F TC=0+-50	28480	0699-1701
A24R19	0699-1672	5	2	RESISTOR 96.25 .1% .125W F TC=0+-50	28480	0699-1672
A24R20	0699-1673	6	1	RESISTOR 71.15 .1% .125W F TC=0+-50	28480	0699-1673
A24R21	0699-1672	5		RESISTOR 96.25 .1% .125W F TC=0+-50	28480	0699-1672
A24R22	0699-1703	3	2	RESISTOR 61.11 .1% .125W F TC=0+-50	28480	0699-1703
A24R23	0699-1671	4	1	RESISTOR 247.5 .1% .125W F TC=0+-50	28480	0699-1671
A24R24	0699-1703	3		RESISTOR 61.11 .1% .125W F TC=0+-50	28480	0699-1703
A24R25	0757-0442	9	8	RESISTOR 10K 1% .125W F TC=0+-100	24546	C4-1/8-T0-1002-F
A24R26	0757-1094	9	3	RESISTOR 1.47K 1% .125W F TC=0+-100	24546	C4-1/8-T0-1471-F
A24R27	0757-0442	9		RESISTOR 10K 1% .125W F TC=0+-100	24546	C4-1/8-T0-1002-F
A24R28	0698-8827	4	2	RESISTOR 1M 1% .125W F TC=0+-100	28480	0698-8827
A24R29	2100-3211	7	2	RESISTOR-TRMR 1K 10% C TOP-ADJ 1-TRN	28480	2100-3211
A24R30	0698-3162	0	5	RESISTOR 46.4K 1% .125W F TC=0+-100	24546	C4-1/8-T0-4642-F
A24R31	0698-3447	4	1	RESISTOR 422 1% .125W F TC=0+-100	24546	C4-1/8-T0-422R-F
A24R32	0698-0084	9	8	RESISTOR 2.15K 1% .125W F TC=0+-100	24546	C4-1/8-T0-2151-F
A24R33	0698-3444	1	1	RESISTOR 316 1% .125W F TC=0+-100	24546	C4-1/8-T0-316R-F
A24R34	0757-0397	3	5	RESISTOR 68.1 1% .125W F TC=0+-100	24546	C4-1/8-T0-68R1-F
A24R35	0698-3441	8	1	RESISTOR 215 1% .125W F TC=0+-100	24546	C4-1/8-T0-215R-F
A24R36	0757-0280	3		RESISTOR 1K 1% .125W F TC=0+-100	24546	C4-1/8-T0-1001-F
A24R37	0698-0084	9		RESISTOR 2.15K 1% .125W F TC=0+-100	24546	C4-1/8-T0-2151-F
A24R38	2100-3211	7		RESISTOR-TRMR 1K 10% C TOP-ADJ 1-TRN	28480	2100-3211
A24R39	0757-0346	2	3	RESISTOR 10 1% 0.125W F TC=0+-100	24546	C4-1/8-T0-10R0-F
A24R40	0757-0442	9		RESISTOR 10K 1% .125W F TC=0+-100	24546	C4-1/8-T0-1002-F
A24R41	0757-0442	9		RESISTOR 10K 1% .125W F TC=0+-100	24546	C4-1/8-T0-1002-F
A24R42	0757-0397	3		RESISTOR 68.1 1% .125W F TC=0+-100	24546	C4-1/8-T0-68R1-F
A24R43	0757-0397	3		RESISTOR 68.1 1% .125W F TC=0+-100	24546	C4-1/8-T0-68R1-F
A24R44	0757-1094	9		RESISTOR 1.47K 1% .125W F TC=0+-100	24546	C4-1/8-T0-1471-F
A24R45	0698-0082	7	3	RESISTOR 464 1% .125W F TC=0+-100	24546	C4-1/8-T0-4640-F
A24R46	0757-0401	0		RESISTOR 100 1% .125W F TC=0+-100	24546	C4-1/8-T0-101-F
A24R47	0698-3162	0		RESISTOR 46.4K 1% .125W F TC=0+-100	24546	C4-1/8-T0-4642-F
A24R48	0757-0438	3	6	RESISTOR 5.11K 1% .125W F TC=0+-100	24546	C4-1/8-T0-5111-F
A24R49	0757-0438	3		RESISTOR 5.11K 1% .125W F TC=0+-100	24546	C4-1/8-T0-5111-F
A24R50	0698-3442	9	2	RESISTOR 237 1% .125W F TC=0+-100	24546	C4-1/8-T0-237R-F

See introduction to this section for ordering information.
* Indicates factory selected value.

Table 6-3. Replaceable Parts (continued)

Reference Designator	HP Part Number	C D	Qty.	Description	Mfr Code	Mfr Part Number
A24R51	0698-3162	0		RESISTOR 46.4K 1% .125W F TC=0+-100	24546	C4-1/8-T0-4642-F
A24R52	0698-0084	9		RESISTOR 2.15K 1% .125W F TC=0+-100	24546	C4-1/8-T0-2151-F
A24R53	0757-0438	3		RESISTOR 5.11K 1% .125W F TC=0+-100	24546	C4-1/8-T0-5111-F
A24R54	0757-0278	9	2	RESISTOR 1.78K 1% .125W F TC=0+-100	24546	C4-1/8-T0-1781-F
A24R55	0698-0084	9		RESISTOR 2.15K 1% .125W F TC=0+-100	24546	C4-1/8-T0-2151-F
A24R56	0757-0199	3	2	RESISTOR 21.5K 1% .125W F TC=0+-100	24546	C4-1/8-T0-2152-F
A24R57	0698-6630	3	1	RESISTOR 20K .1% .125W F TC=0+-25	28480	0698-6630
A24R58	0698-0084			RESISTOR 2.15K 1% .125W F TC=0+-100	24546	C4-1/8-T0-2151-F
A24R59	0698-6322	0	1	RESISTOR 4K .1% .125W F TC=0+-25	28480	0698-6322
A24R60	0698-8827	4		RESISTOR 1M 1% .125W F TC=0+-100	28480	0698-8827
A24R61	0698-3154	0	1	RESISTOR 4.22K 1% .125W F TC=0+-100	24546	C4-1/8-T0-4221-F
A24R62	0757-0401	0		RESISTOR 100 1% .125W F TC=0+-100	24546	C4-1/8-T0-101-F
A24R63	0757-0280	3		RESISTOR 1K 1% .125W F TC=0+-100	24546	C4-1/8-T0-1001-F
A24R64	0698-3446	3	1	RESISTOR 383 1% .125W F TC=0+-100	24546	C4-1/8-T0-383R-F
A24R65	0757-0394	0		RESISTOR 51.1 1% .125W F TC=0+-100	24546	C4-1/8-T0-511R-F
A24R66	0757-0418	9	1	RESISTOR 619 1% .125W F TC=0+-100	24546	C4-1/8-T0-619R-F
A24R67	0698-3433	8	2	RESISTOR 28.7 1% .125W F TC=0+-100	03888	PME55-1/8-T0-2BR7-F
A24R68	0698-3433	8		RESISTOR 28.7 1% .125W F TC=0+-100	03888	PME55-1/8-T0-2BR7-F
A24R69	0757-0397	3		RESISTOR 68.1 1% .125W F TC=0+-100	24546	C4-1/8-T0-68R1-F
A24R70	0757-0397	3		RESISTOR 68.1 1% .125W F TC=0+-100	24546	C4-1/8-T0-68R1-F
A24R71	0757-1094	9		RESISTOR 1.47K 1% .125W F TC=0+-100	24546	C4-1/8-T0-1471-F
A24R72	0698-0082	7		RESISTOR 464 1% .125W F TC=0+-100	24546	C4-1/8-T0-4640-F
A24R73	0757-0401	0		RESISTOR 100 1% .125W F TC=0+-100	24546	C4-1/8-T0-101-F
A24R74	0698-3162	0		RESISTOR 46.4K 1% .125W F TC=0+-100	24546	C4-1/8-T0-4642-F
A24R75	0757-0438	3		RESISTOR 5.11K 1% .125W F TC=0+-100	24546	C4-1/8-T0-5111-F
A24R76	0757-0438	3		RESISTOR 5.11K 1% .125W F TC=0+-100	24546	C4-1/8-T0-5111-F
A24R77	0757-0401	0		RESISTOR 100 1% .125W F TC=0+-100	24546	C4-1/8-T0-101-F
A24R78	0757-0399	5	1	RESISTOR 82.5 1% .125W F TC=0+-100	24546	C4-1/8-T0-82R5-F
A24R79	0698-3442	9		RESISTOR 237 1% .125W F TC=0+-100	24546	C4-1/8-T0-237R-F
A24R80	0698-3162	0		RESISTOR 46.4K 1% .125W F TC=0+-100	24546	C4-1/8-T0-4642-F
A24R81	0757-0278	9		RESISTOR 1.78K 1% .125W F TC=0+-100	24546	C4-1/8-T0-1781-F
A24R82	0698-0084	9		RESISTOR 2.15K 1% .125W F TC=0+-100	24546	C4-1/8-T0-2151-F
A24R83	0757-0438	3		RESISTOR 5.11K 1% .125W F TC=0+-100	24546	C4-1/8-T0-5111-F
A24R84	0757-0199	3		RESISTOR 21.5K 1% .125W F TC=0+-100	24546	C4-1/8-T0-2152-F
A24R85	0698-0084	9		RESISTOR 2.15K 1% .125W F TC=0+-100	24546	C4-1/8-T0-2151-F
A24R86	0757-0401	0		RESISTOR 100 1% .125W F TC=0+-100	24546	C4-1/8-T0-101-F
A24R87	0757-0280	3		RESISTOR 1K 1% .125W F TC=0+-100	24546	C4-1/8-T0-1001-F
A24R88	0757-0280	3		RESISTOR 1K 1% .125W F TC=0+-100	24546	C4-1/8-T0-1001-F
A24R89	0698-3156	2	2	RESISTOR 14.7K 1% .125W F TC=0+-100	24546	C4-1/8-T0-1472-F
A24R90	0698-3156	2		RESISTOR 14.7K 1% .125W F TC=0+-100	24546	C4-1/8-T0-1472-F
A24R91	0698-3628	3	2	RESISTOR 220 5% 2W MO TC=0+-200	28480	0698-3628
A24R92	0760-0024	0	1	RESISTOR 100 5% 1W MO TC=0+-200	28480	0760-0024
A24R93	0698-3628	3		RESISTOR 220 5% 2W MO TC=0+-200	28480	0698-3628
A24R94	0757-0442	9		RESISTOR 10K 1% .125W F TC=0+-100	24546	C4-1/8-T0-1002-F
A24R95	0698-3160	8	1	RESISTOR 31.6K 1% .125W F TC=0+-100	24546	C4-1/8-T0-3162-F
A24R96	0757-0277	8	2	RESISTOR 49.9 1% .125W F TC=0+-100	24546	C4-1/8-T0-4992-F
A24R97	0683-0685	5	1	RESISTOR 6.8 5% .25W FC TC=-400/+500	01121	CB68G5
A24R98	0757-0280	3		RESISTOR 1K 1% .125W F TC=0+-100	24546	C4-1/8-T0-1001-F
A24R99	0757-0346	2	2	RESISTOR 10 1% .125W F TC=0+-100	24546	C4-1/8-T0-10R0-F

See introduction to this section for ordering information.
* Indicates factory selected value.

Table 6-3. Replaceable Parts (continued)

Reference Designator	HP Part Number	C D	Qty.	Description	Mfr Code	Mfr Part Number
A24R100	0757-0346	2		RESISTOR 10 1% .125W F TC=0+-100	24546	C4-1/8-T0-10R0-F
A24R101	0757-0442	9		RESISTOR 10K 1% .125W F TC=0+-100	24546	C4-1/8-T0-1002-F
A24R102	0757-0442	9		RESISTOR 10K 1% .125W F TC=0+-100	24546	C4-1/8-T0-1002-F
A24R103	0757-0442	9		RESISTOR 10K 1% .125W F TC=0+-100	24546	C4-1/8-T0-1002-F
A24R104	2100-3252	6	1	RESISTOR-TRMR 5K 10% C TOP-ADJ 1-TRN	28480	2100-3252
A24R105	0698-4367	9	1	RESISTOR 20.5 1% .125W F TC=0+-100	03888	PME55-1/8-T0-20R5-F
A24R106	0757-0277	8		RESISTOR 49.9 1% .125W F TC=0+-100	24546	C4-1/8-T0-4992-F
A24R107	0757-0401	0		RESISTOR 100 1% .125W F TC=0+-100	24546	C4-1/8-T0-101-F
A24R108	0757-0401	0		RESISTOR 100 1% .125W F TC=0+-100	24546	C4-1/8-T0-101-F
A24R109	2100-3210	6	1	RESISTOR-TRMR 10K 10% C TOP-ADJ 1-TRN	28480	2100-3210
A24R110	0757-0180	2	1	RESISTOR 31.6 1% .125W F TC=0+-100	28480	0757-0180
A24R111	0757-0397	3		RESISTOR 68.1 1% .125W F TC=0+-100		
A24R112	0698-0084	9		RESISTOR 2.15K 1% .125W F TC=0+-100	24546	C4-1/8-T0-2151-F
A24R113	0698-0082	7		RESISTOR 464 1% .125W F TC=0+-100	24546	C4-1/8-T0-4640-F
A24U1	1826-0147	9	1	IC 7812 V RGLTR TO-220	04713	MC7812CP
A24U2	1826-0221	0	1	IC V RGLTR TO-220	04713	MC7912CT
A24U3	1826-0122	0	1	IC 7805 V RGLTR TO-220	07263	7805UC
A24U4	1820-1470	1	1	IC MUXR/DATA-SEL TTL LS 2-TO-1-LINE QUAD	01295	SN74LS157N
A24U5	1858-0047	5	2	TRANSISTOR ARRAY 16-PIN PLSTC DIP	13606	ULN-2003A
A24U6	1820-1433	6	3	IC SHF-RGTR TTL LS R-S SERIAL-IN PRL-OUT	01295	SN74LS164N
A24U7	1820-1416	5	1	IC SCHMITT-TRIG TTL LS INV HEX 1-INP	01295	SN74LS14N
A24U8	1826-0275	4	2	IC 78L12A V RGLTR TO-92	04713	MC78L12ACP
A24U9	1826-1328	0	2	IC OP AMP LOW-NOISE DUAL 8-DIP-P PKG	28480	1826-1328
A24U10	1826-0476	7	1	IC SWITCH ANLG 8-DIP-P PKG	01295	TL601CP
A24U11	1820-1197	9	1	IC GATE TTL LS NAND QUAD 2-INP	01295	SN74LS00N
A24U12	1820-1730	6	2	IC FF TTL LS D-TYPE POS-EDGE-TRIG COM	01295	SN74LS273N
A24U13	1820-1433	6		IC SHF-RGTR TTL LS R-S SERIAL-IN PRL-OUT	01295	SN74LS164N
A24U14	1820-1433	6		IC SHF-RGTR TTL LS R-S SERIAL-IN PRL-OUT	01295	SN74LS164N
A24U15	1820-1730	6		IC FF TTL LS D-TYPE POS-EDGE-TRIG COM	01295	SN74LS273N
A24U16	1826-1386	4	1	IC AD7541AKN	28480	AD7541AKN
A24U17	1826-0635	0	1	IC OP AMP LOW-OFS 8-DIP-P PKG	06665	OP-07CP
A24U18	1858-0047	5		TRANSISTOR ARRAY 16-PIN PLSTC DIP	13606	ULN-2003A
A24U19	1826-1374	6	1	IC LT1037CH	28480	1826-1374
A24U20	1826-1328	0		IC OP AMP LOW-NOISE DUAL 8-DIP-P PKG	28480	NE 5532P
A24U21	1826-0275	4		78L12A V RGLTR TO-92	04713	1826-1328

See introduction to this section for ordering information.
* Indicates factory selected value.

Table 6-3. Replaceable Parts (continued)

Reference Designator	HP Part Number	C D	Qty.	Description	Mfr Code	Mfr Part Number
A24A1	04194-66553	3	1	POWER SPLITTER BOARD ASSEMBLY	28480	04194-66553
A24A1C1	0180-3363	6	6	CAPACITOR-FXD 22UF+-20% 25VDC AL	28480	0180-3363
A24A1C2	0180-3363	6		CAPACITOR-FXD 22UF+-20% 25VDC AL	28480	0180-3363
A24A1C3	0160-2237	9	1	CAPACITOR-FXD 1.2PF +- .25PF 500VDC CER	28480	0160-2237
A24A1C4	0180-3363	6		CAPACITOR-FXD 22UF+-20% 25VDC AL	28480	0180-3363
A24A1C5	0180-3363	6		CAPACITOR-FXD 22UF+-20% 25VDC AL	28480	0180-3363
A24A1C6	0180-3363	6		CAPACITOR-FXD 22UF+-20% 25VDC AL	28480	0180-3363
A24A1C7	0180-3363	6		CAPACITOR-FXD 22UF+-20% 25VDC AL	28480	0180-3363
A24A1C8	0160-4796	9	2	CAPACITOR-FXD 3.9PF +- .25PF 100VDC CER	28480	0160-4796
A24A1C9	0160-4796	9		CAPACITOR-FXD 3.9PF +- .25PF 100VDC CER	28480	0160-4796
A24A1C10	0160-4832	4	5	CAPACITOR-FXD .01UF +-10% 100VDC CER	28480	0160-4832
A24A1C11	0160-4832	4		CAPACITOR-FXD .01UF +-10% 100VDC CER	28480	0160-4832
A24A1C12	0160-4832	4		CAPACITOR-FXD .01UF +-10% 100VDC CER	28480	0160-4832
A24A1C13	0160-4832	4		CAPACITOR-FXD .01UF +-10% 100VDC CER	28480	0160-4832
A24A1C14	0160-4832	4		CAPACITOR-FXD .01UF +-10% 100VDC CER	28480	0160-4832
A24A1CR1	1902-0945	7	2	DIODE-ZNR 3V 5% DO-35 PD=.4W TC=-.043%	28480	1902-0945
A24A1CR2	1901-0050	3	2	DIODE-SWITCHING 80V 200MA 2NS DO-35	28480	1901-0050
A24A1CR3	1901-0050	3		DIODE-SWITCHING 80V 200MA 2NS DO-35	28480	1901-0050
A24A1CR4	1902-0945	7		DIODE-ZNR 3V 5% DO-35 PD=.4W TC=-.043%	28480	1902-0945
A24A1J1	1251-4683	7	6	CONNECTOR-SGL CONT SKT .04-IN-BSC-SZ RND	28480	1251-4683
A24A1J2	1251-4683	7		CONNECTOR-SGL CONT SKT .04-IN-BSC-SZ RND	28480	1251-4683
A24A1J3	1251-4683	7		CONNECTOR-SGL CONT SKT .04-IN-BSC-SZ RND	28480	1251-4683
A24A1J4	1251-4683	7		CONNECTOR-SGL CONT SKT .04-IN-BSC-SZ RND	28480	1251-4683
A24A1J5	1251-4683	7		CONNECTOR-SGL CONT SKT .04-IN-BSC-SZ RND	28480	1251-4683
A24A1J6	1251-4683	7		CONNECTOR-SGL CONT SKT .04-IN-BSC-SZ RND	28480	1251-4683
A24A1J7	1250-1810	4	3	CONNECTOR-RF SMB M PC-OHM	28480	1250-1810
A24A1J8	1250-1810	4		CONNECTOR-RF SMB M PC-OHM	28480	1250-1810
A24A1J9	1250-1810	4		CONNECTOR-RF SMB M PC-OHM	28480	1250-1810
A24A1K1	0490-1485	6	3	RELAY SW	28480	0490-1485
A24A1K2	0490-1485	6		RELAY SW	28480	0490-1485
A24A1K3	0490-1485	6		RELAY SW	28480	0490-1485
A24A1L1	9100-2259	8	6	INDUCTOR RF-CH-MLD 1.5UH 10% .105DX.26LG	28480	9100-2259
A24A1L2	9100-2259	8		INDUCTOR RF-CH-MLD 1.5UH 10% .105DX.26LG	28480	9100-2259
A24A1L3	9100-2259	8		INDUCTOR RF-CH-MLD 1.5UH 10% .105DX.26LG	28480	9100-2259
A24A1L4	9100-2259	8		INDUCTOR RF-CH-MLD 1.5UH 10% .105DX.26LG	28480	9100-2259
A24A1L5	9100-2259	8		INDUCTOR RF-CH-MLD 1.5UH 10% .105DX.26LG	28480	9100-2259
A24A1L6	9100-2259	8		INDUCTOR RF-CH-MLD 1.5UH 10% .105DX.26LG	28480	9100-2259
A24A1R1	0699-1703	3	2	RESISTOR 61.11 .1% .125W F TC=0+-50	28480	0699-1703
A24A1R2	0699-1671	4	1	RESISTOR 247.5 .1% .125W F TC=0+-50	28480	0699-1671
A24A1R3	0699-1703	3		RESISTOR 61.11 .1% .125W F TC=0+-50	28480	0699-1703
A24A1R4	0699-1672	5	2	RESISTOR 96.25 .1% .125W F TC=0+-50	28480	0699-1672
A24A1R5	0699-1673	6	1	RESISTOR 71.15 .1% .125W F TC=0+-50	28480	0699-1673
A24A1R6	0699-1672	5		RESISTOR 96.25 .1% .125W F TC=0+-50	28480	0699-1672
A24A1R7	0757-0277	8	4	RESISTOR 49.9 1% .125W F TC=0+-100	24546	C4-1/8-T0-4992-F
A24A1R8	0757-0442	9	1	RESISTOR 10K 1% .125W F TC=0+-100	24546	C4-1/8-T0-1002-F
A24A1R9	0698-0083	8	1	RESISTOR 1.96K 1% .125W F TC=0+-100	24546	C4-1/8-T0-1961-F
A24A1R10	0757-0277	8		RESISTOR 49.9 1% .125W F TC=0+-100	24546	C4-1/8-T0-4992-F
A24A1R11	0698-6364	0	2	RESISTOR 50 .1% .125W F TC=0+-25	28480	0698-6364

See introduction to this section for ordering information.
 * Indicates factory selected value.

Table 6-3. Replaceable Parts (continued)

Reference Designator	HP Part Number	C D	Qty.	Description	Mfr Code	Mfr Part Number
A24A1R12	0757-0277	8		RESISTOR 49.9 1% .125W F TC=0+-100	24546	C4-1/8-T0-4992-F
A24A1R12	0757-0277	8		RESISTOR 49.9 1% .125W F TC=0+-100	24546	C4-1/8-T0-4992-F
A24A1R14	0698-6364	0		RESISTOR 50 .1% .125W F TC=0+-25	28480	0698-6364
A24A1TP1	0360-1653	5	1	CONNECTOR-SGL CONT PIN .045-IN-BSC-SZ SQ	28480	0360-1653

See introduction to this section for ordering information.
 * Indicates factory selected value.

Table 6-3. Replaceable Parts (continued)

Reference Designator	HP Part Number	C D	Qty.	Description	Mfr Code	Mfr Part Number
A25	04194-66525	9	1	HIGH STABILITY OSCILLATOR BOARD ASSEMBLY	28480	04194-66525
A25C1	0160-4832	4	2	CAPACITOR-FXD .01UF +-10% 100VDC CER	28480	0160-4832
A25C2	0160-4832	4		CAPACITOR-FXD .01UF +-10% 100VDC CER	28480	0160-4832
A25C3	0180-3470	6	1	CAPACITOR-FXD 220UF +-20% 25VDC AL	28480	0180-3470
A25C4	0160-4791	4	1	CAPACITOR-FXD 10PF +-5% 100VDC CER 0+-30	28480	0160-4791
A25C5	0180-3363	6	2	CAPACITOR-FXD 22UF +-20% 25VDC AL	28480	0180-3363
A25C6	0180-3363	6		CAPACITOR-FXD 22UF +-20% 25VDC AL	28480	0180-3363
A25CR1	1902-0953	7	1	DIODE-ZNR 6.2V 5% DO-35 PD=.4W TC=+.053%	28480	1902-0953
A25CR2	1901-0050	3	2	DIODE-SWITCHING 80V 200MA 2NS DO-35	28480	1901-0050
A25CR3	1901-0050	3		DIODE-SWITCHING 80V 200MA 2NS DO-35	28480	1901-0050
A25E1	0960-0465	7	1	OSCILLATOR 10MHZ	28480	0960-0465
A25J1	1250-0257	1	1	CONNECTOR-RF SMB M PC 50-OHM	28480	1250-0257
A25L1	9100-1619	2	1	INDUCTOR RF-CH-MLD 6.8UH 10%	28480	9100-1619
A25Q1	1854-0810	2	1	TRANSISTOR NPN SI PD=625MW FT=200MHZ	28480	1854-0810
A25Q2	1853-0084	0	1	TRANSISTOR PNP 2N4918 SI PD=30W FT=3MHZ	04713	2N4918
A25R1	0757-0401	0	1	RESISTOR 100 1% .125W F TC=0+-100	24546	C4-1/8-T0-101-F
A25R2	2100-3252	6	1	RESISTOR-TRMR 5K 10% C TOP-ADJ 1-TRN	28480	2100-3252
A25R3	0757-0288	1	1	RESISTOR 9.09K 1% .125W F TC=0+-100	19701	MF4C1/8-T0-9091-F
A25R4	2100-3211	7	1	RESISTOR-TRMR 1K 10% C TOP-ADJ 1-TRN	28480	2100-3211
A25R5	0757-0442	9	3	RESISTOR 10K 1% .125W F TC=0+-100	24546	C4-1/8-T0-1002-F
A25R6	0757-0442	9		RESISTOR 10K 1% .125W F TC=0+-100	24546	C4-1/8-T0-1002-F
A25R7	0757-0465	6	1	RESISTOR 100K 1% .125W F TC=0+-100	24546	C4-1/8-T0-1003-F
A25R8	0757-0279	0	1	RESISTOR 3.16K 1% .125W F TC=0+-100	24546	C4-1/8-T0-3161-F
A25R9	0757-0280	3	3	RESISTOR 1K 1% .125W F TC=0+-100	24546	C4-1/8-T0-1001-F
A25R10	0757-0280	3		RESISTOR 1K 1% .125W F TC=0+-100	24546	C4-1/8-T0-1001-F
A25R11	0757-0290	5	1	RESISTOR 6.19K 1% .125W F TC=0+-100	19701	MF4C1/8-T0-6191-F
A25R12	0757-0280	3		RESISTOR 1K 1% .125W F TC=0+-100	24546	C4-1/8-T0-1001-F
A25R13	0698-0084	9	1	RESISTOR 2.15K 1% .125W F TC=0+-100	24546	C4-1/8-T0-2151-F
A25R14	0757-0442	9		RESISTOR 10K 1% .125W F TC=0+-100	24546	C4-1/8-T0-1002-F
A25R15	0698-3430	5	1	RESISTOR 21.5 1% .125W F TC=0+-100	03888	PME55-1/8-T0-21R5-F
A25TP1	0360-1653	5	3	CONNECTOR-SGL CONT PIN .045-IN-BSC-SZ SQ	28480	0360-1653
A25TP2	0360-1653	5		CONNECTOR-SGL CONT PIN .045-IN-BSC-SZ SQ	28480	0360-1653
A25TP3	0360-1653	5		CONNECTOR-SGL CONT PIN .045-IN-BSC-SZ SQ	28480	0360-1653
A25U1	1826-0519	9	1	IC OP AMP LOW-BIAS-H-IMPD 8-DIP-P PKG	01295	TL071CP
A25W1	04194-61653			CABLE ASSY		

See introduction to this section for ordering information.
 * Indicates factory selected value.

Table 6-3. Replaceable Parts (continued)

Reference Designator	HP Part Number	C D	Qty.	Description	Mfr Code	Mfr Part Number
A26	04194-66526	0	1	MEASUREMENT UNIT KEYBOARD ASSEMBLY	28480	04194-66526
A26C1	0180-1085	5	3	CAPACITOR-FXD 4.7UF 16VDC TA	28480	0180-1085
A26C2	0180-1085	5		CAPACITOR-FXD 4.7UF 16VDC TA	28480	0180-1085
A26C3	0180-1085	5		CAPACITOR-FXD 4.7UF 16VDC TA	28480	0180-1085
A26DS1	1990-0517	4	3	LED-LAMP LUM-INT=3MCD IF=20MA-MAX BVR=5V	28480	5082-4655
A26DS2	1990-0487	7	10	LED-LAMP LUM-INT=1MCD IF=20MA-MAX BVR=5V	28480	5082-4584
A26DS3	1990-0487	7		LED-LAMP LUM-INT=1MCD IF=20MA-MAX BVR=5V	28480	5082-4584
A26DS4	1990-0487	7		LED-LAMP LUM-INT=1MCD IF=20MA-MAX BVR=5V	28480	5082-4584
A26DS5	1990-0487	7		LED-LAMP LUM-INT=1MCD IF=20MA-MAX BVR=5V	28480	5082-4584
A26DS6	1990-0487	7		LED-LAMP LUM-INT=1MCD IF=20MA-MAX BVR=5V	28480	5082-4584
A26DS7	1990-0487	7		LED-LAMP LUM-INT=1MCD IF=20MA-MAX BVR=5V	28480	5082-4584
A26DS8	1990-0487	7		LED-LAMP LUM-INT=1MCD IF=20MA-MAX BVR=5V	28480	5082-4584
A26DS9	1990-0487	7		LED-LAMP LUM-INT=1MCD IF=20MA-MAX BVR=5V	28480	5082-4584
A26DS10	1990-0487	7		LED-LAMP LUM-INT=1MCD IF=20MA-MAX BVR=5V	28480	5082-4584
A26DS11	1990-0487	7		LED-LAMP LUM-INT=1MCD IF=20MA-MAX BVR=5V	28480	5082-4584
A26DS12	1990-0517	4		LED-LAMP LUM-INT=3MCD IF=20MA-MAX BVR=5V	28480	5082-4655
A26DS13	1990-0517	4		LED-LAMP LUM-INT=3MCD IF=20MA-MAX BVR=5V	28480	5082-4655
A26J1	1200-0541	1	1	SOCKET-IC 24-CONT DIP DIP-SLDR	28480	1200-0541
A26R1	0698-3441	8	14	RESISTOR 215 1% .125W F TC=0+-100	24546	C4-1/8-T0-215R-F
A26R2	0698-3441	8		RESISTOR 215 1% .125W F TC=0+-100	24546	C4-1/8-T0-215R-F
A26R3	0698-3441	8		RESISTOR 215 1% .125W F TC=0+-100	24546	C4-1/8-T0-215R-F
A26R4	0698-3441	8		RESISTOR 215 1% .125W F TC=0+-100	24546	C4-1/8-T0-215R-F
A26R5	0698-3441	8		RESISTOR 215 1% .125W F TC=0+-100	24546	C4-1/8-T0-215R-F
A26R6	0698-3441	8		RESISTOR 215 1% .125W F TC=0+-100	24546	C4-1/8-T0-215R-F
A26R7	0698-3441	8		RESISTOR 215 1% .125W F TC=0+-100	24546	C4-1/8-T0-215R-F
A26R8	0698-3441	8		RESISTOR 215 1% .125W F TC=0+-100	24546	C4-1/8-T0-215R-F
A26R9	0698-3441	8		RESISTOR 215 1% .125W F TC=0+-100	24546	C4-1/8-T0-215R-F
A26R10	0698-3441	8		RESISTOR 215 1% .125W F TC=0+-100	24546	C4-1/8-T0-215R-F
A26R11	0698-3441	8		RESISTOR 215 1% .125W F TC=0+-100	24546	C4-1/8-T0-215R-F
A26R12	0757-0442	9	6	RESISTOR 10K 1% .125W F TC=0+-100	24546	C4-1/8-T0-1002-F
A26R13	0757-0442	9		RESISTOR 10K 1% .125W F TC=0+-100	24546	C4-1/8-T0-1002-F
A26R14	0757-0442	9		RESISTOR 10K 1% .125W F TC=0+-100	24546	C4-1/8-T0-1002-F
A26R15	0757-0442	9		RESISTOR 10K 1% .125W F TC=0+-100	24546	C4-1/8-T0-1002-F
A26R16	0757-0442	9		RESISTOR 10K 1% .125W F TC=0+-100	24546	C4-1/8-T0-1002-F
A26R17	0698-3441	8		RESISTOR 215 1% .125W F TC=0+-100	24546	C4-1/8-T0-215R-F
A26R18	0698-3441	8		RESISTOR 215 1% .125W F TC=0+-100	24546	C4-1/8-T0-215R-F
A26R19	0698-3441	8		RESISTOR 215 1% .125W F TC=0+-100	24546	C4-1/8-T0-215R-F
A26R20	0757-0442	9		RESISTOR 10K 1% .125W F TC=0+-100	24546	C4-1/8-T0-1002-F
A26S1	5060-9436	7	5	PUSHBUTTON SWITCH P.C. MOUNT	28480	5060-9436
A26S2	5060-9436	7		PUSHBUTTON SWITCH P.C. MOUNT	28480	5060-9436
A26S3	5060-9436	7		PUSHBUTTON SWITCH P.C. MOUNT	28480	5060-9436
A26S4	5060-9436	7		PUSHBUTTON SWITCH P.C. MOUNT	28480	5060-9436
A26S5	5060-9436	7		PUSHBUTTON SWITCH P.C. MOUNT	28480	5060-9436
A26S6	3101-2850	2	1	SWITCH SLIDE	28480	3101-2850
A26U1	1820-1199	1	1	IC INV TTL LS HEX 1-INP	01295	SN74LS04N
A26U2	1820-1207	2	1	IC GATE TTL LS NAND 8-INP	01295	SN74LS30N
A26U3	1820-1197	9	3	IC GATE TTL LS NAND QUAD 2-INP	01295	SN74LS00N
A26U4	1820-1197	9		IC GATE TTL LS NAND QUAD 2-INP	01295	SN74LS00N

See introduction to this section for ordering information.
 * Indicates factory selected value.

Table 6-3. Replaceable Parts (continued)

Reference Designator	HP Part Number	C D	Qty.	Description	Mfr Code	Mfr Part Number
A26U5	1820-1197			IC GATE TTL LS NAND QUAD 2-INP	01295	SN74LS00N
A26U6	1858-0047		2	TRANSISTOR ARRAY 16-PIN PLSTC DIP	13606	ULN-2003A
A26U7	1858-0047			TRANSISTOR ARRAY 16-PIN PLSTC DIP	13606	ULN-2003A
	5041-0276		5	KEY CAP PRL GRAY	28480	5041-0276

See introduction to this section for ordering information.
 * Indicates factory selected value.

Table 6-3. Replaceable Parts (continued)

Reference Designator	HP Part Number	C D	Qty.	Description	Mfr Code	Mfr Part Number
A31	04194-66531	5	1	PROCESS AMPLIFIER BOARD ASSEMBLY FOR OPTION 375 UNITS	28480	04194-66521
A31A1	04194-66571	1	1	TEST AMP BD ASSY	28480	04194-66571
A31A2	04194-66572	2	1	REF AMP BD ASSY	28480	04194-66572
A31C1	0160-4833	5	2	CAPACITOR-FXD .022UF +-10% 100VDC CER	28480	0160-4833
A31C2	0160-4805	1	4	CAPACITOR-FXD 47PF +-5% 100VDC CER 0+-30	28480	0160-4805
A31C3	0160-4810	8	1	CAPACITOR-FXD 330PF +-5% 100VDC CER	28480	0160-4810
A31C4	0160-4801	7	1	CAPACITOR-FXD 100PF +-5% 100VDC CER	28480	0160-4801
A31C5	0180-1085	5	31	CAPACITOR-FXD 4.7UF 16VDC TA	28480	0180-1085
A31C6	0180-1085	5		CAPACITOR-FXD 4.7UF 16VDC TA	28480	0180-1085
A31C7	0121-0060	0	1	CAPACITOR-V TRMR-CER 2-8PF 350V PC-MTG	52763	304322 2/8PF NPO
A31C8				NOT ASSIGNED		
A31C8				NOT ASSIGNED		
A31C8				NOT ASSIGNED		
A31C9	0160-4799	2	1	CAPACITOR-FXD 2.2PF +- .25PF 100VDC CER	28480	0160-4799
A31C10	0160-4832	4	9	CAPACITOR-FXD .01UF +-10% 100VDC CER	28480	0160-4832
A31C11	0180-1085	5		CAPACITOR-FXD 4.7UF 16VDC TA	28480	0180-1085
A31C12	0160-4805	1		CAPACITOR-FXD 47PF +-5% 100VDC CER 0+-30	28480	0160-4805
A31C13	0160-4791	4	1	CAPACITOR-FXD 10PF +-5% 100VDC CER 0+-30	28480	0160-4791
A31C14	0180-1085	5		CAPACITOR-FXD 4.7UF 16VDC TA	28480	0180-1085
A31C15				NOT ASSIGNED		
A31C16				NOT ASSIGNED		
A31C17	0160-4832	4		CAPACITOR-FXD .01UF +-10% 100VDC CER	28480	0160-4832
A31C18	0180-1085	5		CAPACITOR-FXD 4.7UF 16VDC TA	28480	0180-1085
A31C19	0180-1085	5		CAPACITOR-FXD 4.7UF 16VDC TA	28480	0180-1085
A31C20	0180-1085	5		CAPACITOR-FXD 4.7UF 16VDC TA	28480	0180-1085
A31C21	0160-4835	7	6	CAPACITOR-FXD .1UF +-10% 50VDC CER	28480	0160-4835
A31C22	0180-1085	5		CAPACITOR-FXD 4.7UF 16VDC TA	28480	0180-1085
A31C23	0160-4835	7		CAPACITOR-FXD .1UF +-10% 50VDC CER	28480	0160-4835
A31C24				NOT ASSIGNED		
A31C25	0160-6344	7	2	CAP 5600PF	28480	0160-6344
A31C26	0160-0127	2	3	CAPACITOR-FXD 1UF +-20% 25VDC CER	28480	0160-0127
A31C27	0160-4805	1		CAPACITOR-FXD 47PF +-5% 100VDC CER 0+-30	28480	0160-4805
A31C28	0160-4832	4		CAPACITOR-FXD .01UF +-10% 100VDC CER	28480	0160-4832
A31C29	0180-1085	5		CAPACITOR-FXD 4.7UF 16VDC TA	28480	0180-1085
A31C30	0160-6344	7		CAP 5600PF	28480	0160-6344
A31C31	0160-6336	7		CAP 2200PF	28480	0160-6336
A31C32	0180-1085	5		CAPACITOR-FXD 4.7UF 16VDC TA	28480	0180-1085
A31C33	0180-0197	8	6	CAPACITOR-FXD 2.2UF +-10% 20VDC TA	56289	150D225X9020A2

See introduction to this section for ordering information.
* Indicates factory selected value.

Table 6-3. Replaceable Parts (continued)

Reference Designator	HP Part Number	C D	Qty.	Description	Mfr Code	Mfr Part Number
A31C34				NOT ASSIGNED		
A31C35	0160-6336	7		CAP 2200PF	28480	0160-6336
A31C36	0160-4813	1	1	CAPACITOR-FXD 180PF +-5% 100VDC CER	28480	0160-4813
A31C37	0180-1085	5		CAPACITOR-FXD 4.7UF 16VDC TA	28480	0180-1085
A31C38	0180-1085	5		CAPACITOR-FXD 4.7UF 16VDC TA	28480	0180-1085
A31C39	0180-0197	8		CAPACITOR-FXD 2.2UF +-10% 20VDC TA	56289	150D225X9020A2
A31C40	0180-0197	8		CAPACITOR-FXD 2.2UF +-10% 20VDC TA	56289	150D225X9020A2
A31C41	0180-0197	8		CAPACITOR-FXD 2.2UF +-10% 20VDC TA	56289	150D225X9020A2
A31C42	0180-0197	8		CAPACITOR-FXD 2.2UF +-10% 20VDC TA	56289	150D225X9020A2
A31C43	0180-0197	8		CAPACITOR-FXD 2.2UF +-10% 20VDC TA	56289	150D225X9020A2
A31C44	0160-4832	4		CAPACITOR-FXD .01UF +-10% 100VDC CER	28480	0160-4832
A31C45	0180-3469	3	5	CAPACITOR-FXD 100UF +-20% 25VDC AL	28480	0180-3469
A31C46	0180-1085	5		CAPACITOR-FXD 4.7UF 16VDC TA	28480	0180-1085
A31C47	0160-4804	0	2	CAPACITOR-FXD 56PF +-5% 100VDC CER 0+-30	28480	0160-4804
A31C48	0160-4807	3	3	CAPACITOR-FXD 33PF +-5% 100VDC CER 0+-30	28480	0160-4807
A31C49	0160-4835	7		CAPACITOR-FXD .1UF +-10% 50VDC CER	28480	0160-4835
A31C50	0160-4804	0		CAPACITOR-FXD 56PF +-5% 100VDC CER 0+-30	28480	0160-4804
A31C51	0160-0127	2		CAPACITOR-FXD 1UF +-20% 25VDC CER	28480	0160-0127
A31C52	0160-0127	2		CAPACITOR-FXD 1UF +-20% 25VDC CER	28480	0160-0127
A31C53	0160-4807	3		CAPACITOR-FXD 33PF +-5% 100VDC CER 0+-30	28480	0160-4807
A31C54				NOT ASSIGNED		
A31C55	0180-1085	5		CAPACITOR-FXD 4.7UF 16VDC TA	28480	0180-1085
A31C56	0160-4832	4		CAPACITOR-FXD .01UF +-10% 100VDC CER	28480	0160-4832
A31C57	0180-1085	5		CAPACITOR-FXD 4.7UF 16VDC TA	28480	0180-1085
A31C58	0180-1085	5		CAPACITOR-FXD 4.7UF 16VDC TA	28480	0180-1085
A31C59	0180-1085	5		CAPACITOR-FXD 4.7UF 16VDC TA	28480	0180-1085
A31C60	0180-1085	5		CAPACITOR-FXD 4.7UF 16VDC TA	28480	0180-1085
A31C61	0180-3469	3		CAPACITOR-FXD 100UF +-20% 25VDC AL	28480	0180-3469
A31C62	0180-1085	5		CAPACITOR-FXD 4.7UF 16VDC TA	28480	0180-1085
A31C63	0180-1085	5		CAPACITOR-FXD 4.7UF 16VDC TA	28480	0180-1085
A31C64	0160-4830	2	3	CAPACITOR-FXD 2200PF +-10% 100VDC CER	28480	0160-4830
A31C65	0180-3469	3		CAPACITOR-FXD 100UF +-20% 25VDC AL	28480	0180-3469
A31C66	0160-4795	8	2	CAPACITOR-FXD 4.7PF +-.5PF 100VDC CER	28480	0160-4795
A31C67	0160-4795	8		CAPACITOR-FXD 4.7PF +-.5PF 100VDC CER	28480	0160-4795
A31C68	0160-4832	4		CAPACITOR-FXD .01UF +-10% 100VDC CER	28480	0160-4832
A31C69	0160-4807	3		CAPACITOR-FXD 33PF +-5% 100VDC CER 0+-30	28480	0160-4807
A31C70				NOT ASSIGNED		
A31C71	0160-4789	0		CAPACITOR-FXD 15PF +-5% 100VDC CER 0+-30	28480	0160-4789
A31C72	0160-6422	2	1	CAPACITOR 0.1UF 5%	28480	0160-6422
A31C73	0160-4832	4		CAPACITOR-FXD .01UF +-10% 100VDC CER	28480	0160-4832
A31C74	0160-4835	7		CAPACITOR-FXD .1UF +-10% 50VDC CER	28480	0160-4835
A31C75	0160-4830	2		CAPACITOR-FXD 2200PF +-10% 100VDC CER	28480	0160-4830
A31C76	0180-1085	5		CAPACITOR-FXD 4.7UF 16VDC TA	28480	0180-1085
A31C77	0180-1085	5		CAPACITOR-FXD 4.7UF 16VDC TA	28480	0180-1085
A31C78	0180-1085	5		CAPACITOR-FXD 4.7UF 16VDC TA	28480	0180-1085
A31C79	0180-1085	5		CAPACITOR-FXD 4.7UF 16VDC TA	28480	0180-1085
A31C80				NOT ASSIGNED		
A31C81	0160-4805	1		CAPACITOR-FXD 47PF +-5% 100VDC CER 0+-30	28480	0160-4805
A31C82	0180-1085	5		CAPACITOR-FXD 4.7UF 16VDC TA	28480	0180-1085

See introduction to this section for ordering information.
 * Indicates factory selected value.

Table 6-3. Replaceable Parts (continued)

Reference Designator	HP Part Number	C D	Qty.	Description	Mfr Code	Mfr Part Number
A31C83	0180-1085	5		CAPACITOR-FXD 4.7UF 16VDC TA	28480	0180-1085
A31C84	0160-4833	5		CAPACITOR-FXD .022UF +-10% 100VDC CER	28480	0160-4833
A31C85				NOT ASSIGNED		
A31C86	0160-4822	2	2	CAPACITOR-FXD 1000PF +-5% 100VDC CER	28480	0160-4822
A31C87	0160-4835	7		CAPACITOR-FXD .1UF +-10% 50VDC CER	28480	0160-4835
A31C88	0160-4835	7		CAPACITOR-FXD .1UF +-10% 50VDC CER	28480	0160-4835
A31C89	0160-4822	2		CAPACITOR-FXD 1000PF +-5% 100VDC CER	28480	0160-4822
A31C90	0180-3469	3		CAPACITOR-FXD 100UF +-20% 25VDC AL	28480	0180-3469
A31C91	0180-3469	3		CAPACITOR-FXD 100UF +-20% 25VDC AL	28480	0180-3469
A31C92	0180-1085	5		CAPACITOR-FXD 4.7UF 16VDC TA	28480	0180-1085
A31C93	0180-1085	5		CAPACITOR-FXD 4.7UF 16VDC TA	28480	0180-1085
A31C94	0160-4830	2		CAPACITOR-FXD 2200PF +-10% 100VDC CER	28480	0160-4830
A31C95	0180-1085	5		CAPACITOR-FXD 4.7UF 16VDC TA	28480	0180-1085
A31C96	0180-1085	5		CAPACITOR-FXD 4.7UF 16VDC TA	28480	0180-1085
A31C97	0180-1085	5		CAPACITOR-FXD 4.7UF 16VDC TA	28480	0180-1085
A31CR1	1901-0050	3	16	DIODE-SWITCHING 80V 200MA 2NS DO-35	28480	1901-0050
A31CR2	1901-0050	3		DIODE-SWITCHING 80V 200MA 2NS DO-35	28480	1901-0050
A31CR3	1901-0050	3		DIODE-SWITCHING 80V 200MA 2NS DO-35	28480	1901-0050
A31CR4	1901-0050	3		DIODE-SWITCHING 80V 200MA 2NS DO-35	28480	1901-0050
A31CR5	1901-0050	3		DIODE-SWITCHING 80V 200MA 2NS DO-35	28480	1901-0050
A31CR6	1901-0050	3		DIODE-SWITCHING 80V 200MA 2NS DO-35	28480	1901-0050
A31CR7	1902-0956	0	1	DIODE-ZNR 8.2V 5% DO-35 PD=.4W TC=+.065%	28480	1902-0956
A31CR8	1901-0050	3		DIODE-SWITCHING 80V 200MA 2NS DO-35	28480	1901-0050
A31CR9	1901-0050	3		DIODE-SWITCHING 80V 200MA 2NS DO-35	28480	1901-0050
A31CR10	1901-0050	3		DIODE-SWITCHING 80V 200MA 2NS DO-35	28480	1901-0050
A31CR11	1901-0050	3		DIODE-SWITCHING 80V 200MA 2NS DO-35	28480	1901-0050
A31CR12	1901-0050	3		DIODE-SWITCHING 80V 200MA 2NS DO-35	28480	1901-0050
A31CR13	1901-0050	3		DIODE-SWITCHING 80V 200MA 2NS DO-35	28480	1901-0050
A31CR14	1901-0050	3		DIODE-SWITCHING 80V 200MA 2NS DO-35	28480	1901-0050
A31CR15	1901-0050	3		DIODE-SWITCHING 80V 200MA 2NS DO-35	28480	1901-0050
A31CR16	1901-0050	3		DIODE-SWITCHING 80V 200MA 2NS DO-35	28480	1901-0050
A31CR17	1901-0050	3		DIODE-SWITCHING 80V 200MA 2NS DO-35	28480	1901-0050
A31E1	0955-0252	9	1	U-WAVE MIXER 250MHZ MAX	28480	0955-0252
A31F1	9135-0277	9	3	FILTER-LOWPASS OPER VOLTAGE:50 VDC MAX	28480	9135-0277
A31F2	9135-0276	8	3	FILTER 002-02	28480	9135-0276
A31F3	9135-0277	9		FILTER-LOWPASS OPER VOLTAGE:50 VDC MAX	28480	9135-0277
A31F4	9135-0276	8		FILTER 002-02	28480	9135-0276
A31F5	9135-0276	8		FILTER 002-02	28480	9135-0276
A31F6	9135-0277	9		FILTER-LOWPASS OPER VOLTAGE:50 VDC MAX	28480	9135-0277
A31J1	1250-0257	1	5	CONNECTOR-RF SMB M PC 50-OHM	28480	1250-0257
A31J2	1200-0541	1	1	SOCKET-IC 24-CONT DIP DIP-SLDR	28480	1200-0541
A31J3	1250-0257	1		CONNECTOR-RF SMB M PC 50-OHM	28480	1250-0257
A31J4	1250-0257	1		CONNECTOR-RF SMB M PC 50-OHM	28480	1250-0257
A31J5	1250-0257	1		CONNECTOR-RF SMB M PC 50-OHM	28480	1250-0257
A31J6	1250-0257	1		CONNECTOR-RF SMB M PC 50-OHM	28480	1250-0257
A31J7	0360-0124	3	16	CONNECTOR-SGL CONT PIN .04-IN-BSC-SZ RND	28480	0360-0124
A31J8	0360-0124	3		CONNECTOR-SGL CONT PIN .04-IN-BSC-SZ RND	28480	0360-0124
A31J9	0360-0124	3		CONNECTOR-SGL CONT PIN .04-IN-BSC-SZ RND	28480	0360-0124
A31J10	0360-0124	3		CONNECTOR-SGL CONT PIN .04-IN-BSC-SZ RND	28480	0360-0124

See Introduction to this section for ordering information.
* Indicates factory selected value.

Table 6-3. Replaceable Parts (continued)

Reference Designator	HP Part Number	C D	Qty.	Description	Mfr Code	Mfr Part Number
A31J11	0360-0124		3	CONNECTOR-SGL CONT PIN .04-IN-BSC-SZ RND	28480	0360-0124
A31J12	0360-0124		3	CONNECTOR-SGL CONT PIN .04-IN-BSC-SZ RND	28480	0360-0124
A31J13	0360-0124		3	CONNECTOR-SGL CONT PIN .04-IN-BSC-SZ RND	28480	0360-0124
A31J14	0360-0124		3	CONNECTOR-SGL CONT PIN .04-IN-BSC-SZ RND	28480	0360-0124
A31J15	0360-0124		3	CONNECTOR-SGL CONT PIN .04-IN-BSC-SZ RND	28480	0360-0124
A31J16	0360-0124		3	CONNECTOR-SGL CONT PIN .04-IN-BSC-SZ RND	28480	0360-0124
A31J17	0360-0124		3	CONNECTOR-SGL CONT PIN .04-IN-BSC-SZ RND	28480	0360-0124
A31J18	0360-0124		3	CONNECTOR-SGL CONT PIN .04-IN-BSC-SZ RND	28480	0360-0124
A31J19	0360-0124		3	CONNECTOR-SGL CONT PIN .04-IN-BSC-SZ RND	28480	0360-0124
A31J20	0360-0124		3	CONNECTOR-SGL CONT PIN .04-IN-BSC-SZ RND	28480	0360-0124
A31J21	0360-0124		3	CONNECTOR-SGL CONT PIN .04-IN-BSC-SZ RND	28480	0360-0124
A31J22	0360-0124		3	CONNECTOR-SGL CONT PIN .04-IN-BSC-SZ RND	28480	0360-0124
A31J23	1200-0796		8	1 SOCKET-IC 8-CONT DIP DIP-SLDR	28480	1200-0796
A31J24	1251-4822			3-PIN CONNECTOR		
A31J25	1251-4822			3-PIN CONNECTOR		
A31J26	1251-4822			3-PIN CONNECTOR		
A31K1	0490-1477		6	1 RELAY	28480	0490-1477
A31L1	9140-1137		3	2 COIL 280UH	28480	9140-1137
A31L2	9140-1138		4	1 COIL 670UH	28480	9140-1138
A31L3	9140-1137		3	COIL 280UH	28480	9140-1137
A31L4	9170-0029		3	14 CORE-SHIELDING BEAD	28480	9170-0029
A31L5	9170-0029		3	CORE-SHIELDING BEAD	28480	9170-0029
A31L6	9140-1093		5	8 COIL 10UH 10%	28480	9140-1093
A31L7	9140-1093		5	COIL 10UH 10%	28480	9140-1093
A31L8	9170-0029		3	CORE-SHIELDING BEAD	28480	9170-0029
A31L9	9170-0029		3	CORE-SHIELDING BEAD	28480	9170-0029
A31L10	9170-0029		3	CORE-SHIELDING BEAD	28480	9170-0029
A31L11	9170-0029		3	CORE-SHIELDING BEAD	28480	9170-0029
A31L12	9170-0029		3	CORE-SHIELDING BEAD	28480	9170-0029
A31L13	9170-0029		3	CORE-SHIELDING BEAD	28480	9170-0029
A31L14	9170-0029		3	CORE-SHIELDING BEAD	28480	9170-0029
A31L15	9100-2247		4	5 INDUCTOR RF-CH-MLD 100NH 10% .105DX.26LG	28480	9100-2247
A31L16	9100-2247		4	INDUCTOR RF-CH-MLD 100NH 10% .105DX.26LG	28480	9100-2247
A31L17	9100-2247		4	INDUCTOR RF-CH-MLD 100NH 10% .105DX.26LG	28480	9100-2247
A31L18	9140-1093		0	COIL 10UH 10%	28480	9140-1093
A31L19	9100-2259		8	13 INDUCTOR RF-CH-MLD 1.5UH 10% .105DX.26LG	28480	9100-2259
A31L20	9140-1093		5	COIL 10UH 10%	28480	9140-1093
A31L21	9100-2259		8	INDUCTOR RF-CH-MLD 1.5UH 10% .105DX.26LG	28480	9100-2259
A31L22	9100-2259		8	INDUCTOR RF-CH-MLD 1.5UH 10% .105DX.26LG	28480	9100-2259
A31L23	9100-2259		8	INDUCTOR RF-CH-MLD 1.5UH 10% .105DX.26LG	28480	9100-2259
A31L24	9100-2259		8	INDUCTOR RF-CH-MLD 1.5UH 10% .105DX.26LG	28480	9100-2259
A31L25	9100-2259		8	INDUCTOR RF-CH-MLD 1.5UH 10% .105DX.26LG	28480	9100-2259
A31L26	9140-1093		5	COIL 10UH 10%	28480	9140-1093
A31L27	9100-2247		4	INDUCTOR RF-CH-MLD 100NH 10% .105DX.26LG	28480	9100-2247
A31L28	9100-2247		4	INDUCTOR RF-CH-MLD 100NH 10% .105DX.26LG	28480	9100-2247
A31L29	9170-0029		3	CORE-SHIELDING BEAD	28480	9170-0029
A31L30	9100-2259		8	INDUCTOR RF-CH-MLD 1.5UH 10% .105DX.26LG	28480	9100-2259
A31L31	9100-2259		8	INDUCTOR RF-CH-MLD 1.5UH 10% .105DX.26LG	28480	9100-2259
A31L32	9170-0029		3	CORE-SHIELDING BEAD	28480	9170-0029

See introduction to this section for ordering information.
 * Indicates factory selected value.

Table 6-3. Replaceable Parts (continued)

Reference Designator	HP Part Number	C D	Qty.	Description	Mfr Code	Mfr Part Number
A31L33	9170-0029	3		CORE-SHIELDING BEAD	28480	9170-0029
A31L34	9170-0029	3		CORE-SHIELDING BEAD	28480	9170-0029
A31L35	9170-0029	3		CORE-SHIELDING BEAD	28480	9170-0029
A31L36	9140-1093	5		COIL 10UH 10%	28480	9140-1093
A31L37	9100-2259	8		INDUCTOR RF-CH-MLD 1.5UH 10% .105DX.26LG	28480	9100-2259
A31L38	9100-2259	8		INDUCTOR RF-CH-MLD 1.5UH 10% .105DX.26LG	28480	9100-2259
A31L39	9140-1093	5		COIL 10UH 10%	28480	9140-1093
A31L40	9140-1093	5		COIL 10UH 10%	28480	9140-1093
A31L41	9100-2259	8		INDUCTOR RF-CH-MLD 1.5UH 10% .105DX.26LG	28480	9100-2259
A31L42	9100-2259	8		INDUCTOR RF-CH-MLD 1.5UH 10% .105DX.26LG	28480	9100-2259
A31L43	9100-2259	8		INDUCTOR RF-CH-MLD 1.5UH 10% .105DX.26LG	28480	9100-2259
A31Q1	1853-0459	3	1	TRANSISTOR PNP SI PD=625MW FT=200MHZ	28480	1853-0459
A31Q2	1854-0810	2	1	TRANSISTOR NPN SI PD=625MW FT=200MHZ	28480	1854-0810
A31Q3	1855-0386	9	8	TRANSISTOR J-FET 2N4392 N-CHAN D-MODE	04713	2N4392
A31Q4	1855-0386	9		TRANSISTOR J-FET 2N4392 N-CHAN D-MODE	04713	2N4392
A31Q5	1855-0091	3	1	TRANSISTOR J-FET N-CHAN D-MODE SI	28480	1855-0091
A31Q6	1855-0386	9		TRANSISTOR J-FET 2N4392 N-CHAN D-MODE	04713	2N4392
A31Q7	1855-0386	9		TRANSISTOR J-FET 2N4392 N-CHAN D-MODE	04713	2N4392
A31Q8	1854-1073	1	7	TRANSISTOR NPN SI PD=600MW FT=6.5GHZ	28480	1854-1073
A31Q9	1854-1073	1		TRANSISTOR NPN SI PD=600MW FT=6.5GHZ	28480	1854-1073
A31Q10	1854-1073	1		TRANSISTOR NPN SI PD=600MW FT=6.5GHZ	28480	1854-1073
A31Q11	1854-1073	1		TRANSISTOR NPN SI PD=600MW FT=6.5GHZ	28480	1854-1073
A31Q12	1854-1073	1		TRANSISTOR NPN SI PD=600MW FT=6.5GHZ	28480	1854-1073
A31Q13	1854-0215	1	1	TRANSISTOR NPN SI PD=350MW FT=300MHZ	04713	2N3904
A31Q14	1854-1073	1		TRANSISTOR NPN SI PD=600MW FT=6.5GHZ	28480	1854-1073
A31Q15	1854-0247	9	1	TRANSISTOR NPN SI TO-39 PD=1W FT=800MHZ	28480	1854-0247
A31Q16	1854-1073	1		TRANSISTOR NPN SI PD=600MW FT=6.5GHZ	28480	1854-1073
A31Q17	1855-0386	9		TRANSISTOR J-FET 2N4392 N-CHAN D-MODE	04713	2N4392
A31Q18	1853-0020	4	4	TRANSISTOR PNP SI PD=300MW FT=150MHZ	28480	1853-0020
A31Q19	1855-0386	9		TRANSISTOR J-FET 2N4392 N-CHAN D-MODE	04713	2N4392
A31Q20	1853-0020	4		TRANSISTOR PNP SI PD=300MW FT=150MHZ	28480	1853-0020
A31Q21	1855-0386	9		TRANSISTOR J-FET 2N4392 N-CHAN D-MODE	04713	2N4392
A31Q22	1853-0020	4		TRANSISTOR PNP SI PD=300MW FT=150MHZ	28480	1853-0020
A31Q23	1855-0386	9		TRANSISTOR J-FET 2N4392 N-CHAN D-MODE	04713	2N4392
A31Q24	1853-0020	4		TRANSISTOR PNP SI PD=300MW FT=150MHZ	28480	1853-0020
A31R1	0757-0346	2	12	RESISTOR 10 1% .125W F TC=0+-100	24546	C4-1/8-T0-10R0-F
A31R2	0757-0346	2		RESISTOR 10 1% .125W F TC=0+-100	24546	C4-1/8-T0-10R0-F
A31R3	0757-0199	3	6	RESISTOR 21.5K 1% .125W F TC=0+-100	24546	C4-1/8-T0-2152-F
A31R4	0698-3444	1	5	RESISTOR 316 1% .125W F TC=0+-100	24546	C4-1/8-T0-316R-F
A31R5	0757-0346	2		RESISTOR 10 1% .125W F TC=0+-100	24546	C4-1/8-T0-10R0-F
A31R6	0757-0199	3		RESISTOR 21.5K 1% .125W F TC=0+-100	24546	C4-1/8-T0-2152-F
A31R7	0698-3444	1		RESISTOR 316 1% .125W F TC=0+-100	24546	C4-1/8-T0-316R-F
A31R8	0757-0419	0	2	RESISTOR 681 1% .125W F TC=0+-100	24546	C4-1/8-T0-681R-F
A31R9	0698-0083	8	3	RESISTOR 1.96K 1% .125W F TC=0+-100	24546	C4-1/8-T0-1961-F
A31R10	0757-0416	7	1	RESISTOR 511 1% .125W F TC=0+-100	24546	C4-1/8-T0-511R-F
A31R11	0757-0465	6	3	RESISTOR 100K 1% .125W F TC=0+-100	24546	C4-1/8-T0-1003-F
A31R12	0698-3459	8	4	RESISTOR 383K 1% .125W F TC=0+-100	28480	0698-3459
A31R13	0698-3459	8		RESISTOR 383K 1% .125W F TC=0+-100	28480	0698-3459
A31R14	0757-0280	3	8	RESISTOR 1K 1% .125W F TC=0+-100	24546	C4-1/8-T0-1001-F

See introduction to this section for ordering information.
* Indicates factory selected value.

Table 6-3. Replaceable Parts (continued)

Reference Designator	HP Part Number	C D	Qty.	Description	Mfr Code	Mfr Part Number
A31R15	0698-8827	4	10	RESISTOR 1M 1% .125W F TC=0+-100	28480	0698-8827
A31R16	0757-0459	8	3	RESISTOR 56.2K 1% .125W F TC=0+-100	24546	C4-1/8-T0-5622-F
A31R17	0698-8827	4		RESISTOR 1M 1% .125W F TC=0+-100	28480	0698-8827
A31R18	0698-3459	8		RESISTOR 383K 1% .125W F TC=0+-100	28480	0698-3459
A31R19	0698-3459	8		RESISTOR 383K 1% .125W F TC=0+-100	28480	0698-3459
A31R20	0757-0442	9	18	RESISTOR 10K 1% .125W F TC=0+-100	24546	C4-1/8-T0-1002-F
A31R21	0757-0280	3		RESISTOR 1K 1% .125W F TC=0+-100	24546	C4-1/8-T0-1001-F
A31R22	0757-0465	6		RESISTOR 100K 1% .125W F TC=0+-100	24546	C4-1/8-T0-1003-F
A31R23	0757-0288	1	1	RESISTOR 9.09K 1% .125W F TC=0+-100	19701	MF4C1/8-T0-9091-F
A31R23	0757-0442	9		RESISTOR 10K 1% .125W F TC=0+-100	24546	C4-1/8-T0-1002-F
A31R23	0757-0443	0	1	RESISTOR 11K 1% .125W F TC=0+-100	24546	C4-1/8-T0-1102-F
A31R24	2100-3091	1	2	RESISTOR TRMR 2K 10% C TOP-ADJ 17-TRN	32997	3292W-1-202
A31R25	0699-1706	6	1	RESISTOR 261 .1% .05W F TC=0+-5	28480	0699-1706
A31R26	0699-1702	2	1	RESISTOR 1.78K .1% .05W F TC=0+-5	28480	0699-1702
A31R27	0698-0084	9	3	RESISTOR 2.15K 1% .125W F TC=0+-100	24546	C4-1/8-T0-2151-F
A31R28	0757-0439	3	1	RESISTOR 6.81K 1% .125W F TC=0+-100	24546	C4-1/8-T0-6811-F
A31R29	0698-0084	9		RESISTOR 2.15% .125W F TC=0+-100	24546	C4-1/8-T0-2151-F
A31R30	0698-3150	6	1	RESISTOR 2.37K 1%		
A31R31	0757-0465	6		RESISTOR 100K 1% .125W F TC=0+-100	24546	C4-1/8-T0-1003-F
A31R32	0757-0441	8	2	RESISTOR 8.25K 1% .125W F TC=0+-100	24546	C4-1/8-T0-8251-F
A31R33	0757-0280	3		RESISTOR 1K 1% .125W F TC=0+-100	24546	C4-1/8-T0-1001-F
A31R34	0757-0280	3		RESISTOR 1K 1% .125W F TC=0+-100	24546	C4-1/8-T0-1001-F
A31R35	0757-0280	3		RESISTOR 1K 1% .125W F TC=0+-100	24546	C4-1/8-T0-1001-F
A31R36	0757-0199	3		RESISTOR 21.5K 1% .125W F TC=0+-100	24546	C4-1/8-T0-2152-F
A31R37	0698-3160	8	3	RESISTOR 31.6K 1% .125W F TC=0+-100	24546	C4-1/8-T0-3162-F
A31R38	0698-0082	7	3	RESISTOR 464 1% .125W F TC=0+-100	24546	C4-1/8-T0-4640-F
A31R39	0757-0274	5	3	RESISTOR 1.21K 1% .125W F TC=0+-100	24546	C4-1/8-T0-1211-F
A31R40	0698-3160	8		RESISTOR 31.6K 1% .125W F TC=0+-100	24546	C4-1/8-T0-3162-F
A31R41	0757-0290	5	1	RESISTOR 6.19K 1% .125W F TC=0+-100	19701	MF4C1/8-T0-6191-F
A31R42	0698-3454	3	1	RESISTOR 215K 1% .125W F TC=0+-100	24546	C4-1/8-T0-2153-F
A31R43	0698-3136	8	1	RESISTOR 17.8K 1% .125W F TC=0+-100	24546	C4-1/8-T0-1782-F
A31R44	0757-0459	8		RESISTOR 56.2K 1% .125W F TC=0+-100	24546	C4-1/8-T0-5622-F
A31R45	0757-0428	1	1	RESISTOR 1.62K 1% .125W F TC=0+-100	24546	C4-1/8-T0-1621-F
A31R46	0698-3160	8		RESISTOR 31.6K 1% .125W F TC=0+-100	24546	C4-1/8-T0-3162-F
A31R47	0698-3430	5	6	RESISTOR 21.5 1% .125W F TC=0+-100	03888	PME55-1/8-T0-21R5-F
A31R48	0698-3430	5		RESISTOR 21.5 1% .125W F TC=0+-100	03888	PME55-1/8-T0-21R5-F
A31R49	0757-0280	3		RESISTOR 1K 1% .125W F TC=0+-100	24546	C4-1/8-T0-1001-F
A31R50	0757-0418	9	1	RESISTOR 619 1% .125W F TC=0+-100	24546	C4-1/8-T0-619R-F
A31R51	0757-0401	0	10	RESISTOR 100 1% .125W F TC=0+-100	24546	C4-1/8-T0-101-F
A31R52	0757-0424	0	2	RESISTOR 1.10K 1% .125W F TC=0+-100	24546	C4-1/8-T0-1101-F
A31R53	0757-0346	2		RESISTOR 10 1% .125W F TC=0+-100	24546	C4-1/8-T0-10R0-F
A31R54	0757-0419	0		RESISTOR 681 1% .125W F TC=0+-100	24546	C4-1/8-T0-681R-F
A31R55	0698-0083	8		RESISTOR 1.96K 1% .125W F TC=0+-100	24546	C4-1/8-T0-1961-F
A31R56	0698-3444	1		RESISTOR 316 1% .125W F TC=0+-100	24546	C4-1/8-T0-316R-F
A31R57	0757-0277	8	4	RESISTOR 49.9 1% .125W F TC=0+-100	24546	C4-1/8-T0-4992-F
A31R58	0698-4037	0	3	RESISTOR 46.4 1% .125W F TC=0+-100	24546	C4-1/8-T0-46R4-F
A31R59	0698-3444	1		RESISTOR 316 1% .125W F TC=0+-100	24546	C4-1/8-T0-316R-F
A31R60	0757-0401	0		RESISTOR 100 1% .125W F TC=0+-100	24546	C4-1/8-T0-101-F
A31R61	0757-0401	0		RESISTOR 100 1% .125W F TC=0+-100	24546	C4-1/8-T0-101-F

See introduction to this section for ordering information.
 * Indicates factory selected value.

Table 6-3. Replaceable Parts (continued)

Reference Designator	HP Part Number	C D	Qty.	Description	Mfr Code	Mfr Part Number
A31R62	0757-0279	0		RESISTOR 3.16K 1% .125W F TC=0+-100	24546	C4-1/8-T0-3161-F
A31R63	0757-0420	3	1	RESISTOR 750 1% .125W F TC=0+-100	24546	C4-1/8-T0-751-F
A31R64	0757-0346	2		RESISTOR 10 1% .125W F TC=0+-100	24546	C4-1/8-T0-10R0-F
A31R65	0757-0277	8		RESISTOR 49.9 1% .125W F TC=0+-100	24546	C4-1/8-T0-4992-F
A31R66	0757-0346	2		RESISTOR 10 1% .125W F TC=0+-100	24546	C4-1/8-T0-10R0-F
A31R67	0698-3444	1		RESISTOR 316 1% .125W F TC=0+-100	24546	C4-1/8-T0-316R-F
A31R68	0757-0277	8		RESISTOR 49.9 1% .125W F TC=0+-100	24546	C4-1/8-T0-4992-F
A31R69	0757-0346	2		RESISTOR 10 1% .125W F TC=0+-100	24546	C4-1/8-T0-10R0-F
A31R70	0757-0401	0		RESISTOR 100 1% .125W F TC=0+-100	24546	C4-1/8-T0-101-F
A31R71	0757-0346	2		RESISTOR 10 1% .125W F TC=0+-100	24546	C4-1/8-T0-10R0-F
A31R72	0757-0401	0		RESISTOR 100 1% .125W F TC=0+-100	24546	C4-1/8-T0-101-F
A31R73	0757-0346	2		RESISTOR 10 1% .125W F TC=0+-100	24546	C4-1/8-T0-10R0-F
A31R74				NOT ASSIGNED		
A31R75	0698-3132	4	8	RESISTOR 261 1% .125W F TC=0+-100	24546	C4-1/8-T0-2610-F
A31R76	0698-3429	2	4	RESISTOR 19.6 1% .125W F TC=0+-100	03888	PME55-1/8-T0-19R6-F
A31R77	0698-3132	4		RESISTOR 261 1% .125W F TC=0+-100	24546	C4-1/8-T0-2610-F
A31R78	0757-0401	0		RESISTOR 100 1% .125W F TC=0+-100	24546	C4-1/8-T0-101-F
A31R79	0757-0401	0		RESISTOR 100 1% .125W F TC=0+-100	24546	C4-1/8-T0-101-F
A31R80	0757-0346	2		RESISTOR 10 1% .125W F TC=0+-100	24546	C4-1/8-T0-10R0-F
A31R81	0757-0401	0		RESISTOR 100 1% .125W F TC=0+-100	24546	C4-1/8-T0-101-F
A31R82	0757-0401	0		RESISTOR 100 1% .125W F TC=0+-100	24546	C4-1/8-T0-101-F
A31R83	0757-0401	0		RESISTOR 100 1% .125W F TC=0+-100	24546	C4-1/8-T0-101-F
A31R84	0698-3438	3	2	RESISTOR 147 1% .125W F TC=0+-100	24546	C4-1/8-T0-147R-F
A31R85	0698-3132	4		RESISTOR 261 1% .125W F TC=0+-100	24546	C4-1/8-T0-2610-F
A31R86	0698-3429	2		RESISTOR 19.6 1% .125W F TC=0+-100	03888	PME55-1/8-T0-19R6-F
A31R87	0698-3132	4		RESISTOR 261 1% .125W F TC=0+-100	24546	C4-1/8-T0-2610-F
A31R88	0698-3132	4		RESISTOR 261 1% .125W F TC=0+-100	24546	C4-1/8-T0-2610-F
A31R89	0698-3429	2		RESISTOR 19.6 1% .125W F TC=0+-100	03888	PME55-1/8-T0-19R6-F
A31R90	0698-3132	4		RESISTOR 261 1% .125W F TC=0+-100	24546	C4-1/8-T0-2610-F
A31R91	0698-3132	4		RESISTOR 261 1% .125W F TC=0+-100	24546	C4-1/8-T0-2610-F
A31R92	0698-3429	2		RESISTOR 19.6 1% .125W F TC=0+-100	03888	PME55-1/8-T0-19R6-F
A31R93	0698-3132	4		RESISTOR 261 1% .125W F TC=0+-100	24546	C4-1/8-T0-2610-F
A31R94	0757-0277	8		RESISTOR 49.9 1% .125W F TC=0+-100	24546	C4-1/8-T0-4992-F
A31R95	0698-0082	7		RESISTOR 464 1% .125W F TC=0+-100	24546	C4-1/8-T0-4640-F
A31R96	0698-4037	0		RESISTOR 46.4 1% .125W F TC=0+-100	24546	C4-1/8-T0-46R4-F
A31R97	0757-0442	9		RESISTOR 10K 1% .125W F TC=0+-100	24546	C4-1/8-T0-1002-F
A31R98	0757-0199	3		RESISTOR 21.5K 1% .125W F TC=0+-100	24546	C4-1/8-T0-2152-F
A31R99	0698-3430	5		RESISTOR 21.5 1% .125W F TC=0+-100	03888	PME55-1/8-T0-21R5-F
A31R100	0757-0346	2		RESISTOR 10 1% .125W F TC=0+-100	24546	C4-1/8-T0-10R0-F
A31R101	0698-4037	0		RESISTOR 46.4 1% .125W F TC=0+-100	24546	C4-1/8-T0-46R4-F
A31R102	0698-3430	5		RESISTOR 21.5 1% .125W F TC=0+-100	03888	PME55-1/8-T0-21R5-F
A31R103	0757-0400	9	1	RESISTOR 90.9 1% .125W F TC=0+-100	24546	C4-1/8-T0-90R9-F
A31R104	0698-0083	8		RESISTOR 1.96K 1% .125W F TC=0+-100	24546	C4-1/8-T0-1961-F
A31R105	0698-3430	5		RESISTOR 21.5 1% .125W F TC=0+-100	03888	PME55-1/8-T0-21R5-F
A31R106	0757-0440	7	2	RESISTOR 7.5K 1% .125W F TC=0+-100	24546	C4-1/8-T0-7501-F
A31R107	0698-3155	1	1	RESISTOR 4.64K 1% .125W F TC=0+-100	24546	C4-1/8-T0-4641-F
A31R108	0757-0424	7	1	RESISTOR 1.1K 1% .125W F TC=0+-100	24546	C4-1/8-T0-1101-F
A31R109	0757-0440	7		RESISTOR 7.5K 1% .125W F TC=0+-100	24546	C4-1/8-T0-7501-F
A31R110	0698-3430	5		RESISTOR 21.5 1% .125W F TC=0+-100	03888	PME55-1/8-T0-21R5-F

See introduction to this section for ordering information.
* Indicates factory selected value.

Table 6-3. Replaceable Parts (continued)

Reference Designator	HP Part Number	C D	Qty.	Description	Mfr Code	Mfr Part Number
A31R111	0757-0274	5		RESISTOR 1.21K 1% .125W F TC=0+-100	24546	C4-1/8-T0-1211-F
A31R112	0757-0274	5		RESISTOR 1.21K 1% .125W F TC=0+-100	24546	C4-1/8-T0-1211-F
A31R113	0698-0082	7		RESISTOR 464 1% .125W F TC=0+-100	24546	C4-1/8-T0-4640-F
A31R114	0757-0442	9		RESISTOR 10K 1% .125W F TC=0+-100	24546	C4-1/8-T0-1002-F
A31R115	0698-0084	9		RESISTOR 2.15K 1% .125W F TC=0+-100	24546	C4-1/8-T0-2151-F
A31R116	2100-3091	1		RESISTOR-TRMR 2K 10% C TOP-ADJ 17-TRN	32997	3292W-1-202
A31R117	0698-3154	0		RESISTOR 4.22K 1% .125W F TC=0+-100	24546	C4-1/8-T0-
A31R118	0698-3154	0		RESISTOR 4.22K 1% .125W F TC=0+-100	24546	C4-1/8-T0-
A31R119	0698-8827	4	1	RESISTOR 1M 1% .125W F TC=0+-100	24546	C4-1/8-T0-
A31R120	0757-0421	4		RESISTOR 825 1% .125W F TC=0+-100	24546	C4-1/8-T0-
A31R121	0757-0442	9		RESISTOR 10K 1% .125W F TC=0+-100	24546	C4-1/8-T0-1002-F
A31R122	0757-0442	9		RESISTOR 10K 1% .125W F TC=0+-100	24546	C4-1/8-T0-1002-F
A31R123	0698-8827	4		RESISTOR 1M 1% .125W F TC=0+-100	28480	0698-8827
A31R124	0698-8827	4		RESISTOR 1M 1% .125W F TC=0+-100	28480	0698-8827
A31R125	0757-0442	9		RESISTOR 10K 1% .125W F TC=0+-100	24546	C4-1/8-T0-1002-F
A31R126	0757-0442	9		RESISTOR 10K 1% .125W F TC=0+-100	24546	C4-1/8-T0-1002-F
A31R127	0757-0442	9		RESISTOR 10K 1% .125W F TC=0+-100	24546	C4-1/8-T0-1002-F
A31R128	0757-0442	9		RESISTOR 10K 1% .125W F TC=0+-100	24546	C4-1/8-T0-1002-F
A31R129	0698-8827	4		RESISTOR 1M 1% .125W F TC=0+-100	28480	0698-8827
A31R130	0698-8827	4		RESISTOR 1M 1% .125W F TC=0+-100	28480	0698-8827
A31R131	0757-0459	8		RESISTOR 56.2K 1% .125W F TC=0+-100	24546	C4-1/8-T0-5622-F
A31R132	0757-0441	8		RESISTOR 8.25K 1% .125W F TC=0+-100	24546	C4-1/8-T0-8251-F
A31R133	0698-8827	4		RESISTOR 1M 1% .125W F TC=0+-100	28480	0698-8827
A31R134	0698-8827	4		RESISTOR 1M 1% .125W F TC=0+-100	28480	0698-8827
A31R135	0698-8827	4		RESISTOR 1M 1% .125W F TC=0+-100	28480	0698-8827
A31R136	0698-8827	4		RESISTOR 1M 1% .125W F TC=0+-100	28480	0698-8827
A31R137	0757-0442	9		RESISTOR 10K 1% .125W F TC=0+-100	24546	C4-1/8-T0-1002-F
A31R138	0757-0442	9		RESISTOR 10K 1% .125W F TC=0+-100	24546	C4-1/8-T0-1002-F
A31R139	0757-0442	9		RESISTOR 10K 1% .125W F TC=0+-100	24546	C4-1/8-T0-1002-F
A31R140	0757-0442	9		RESISTOR 10K 1% .125W F TC=0+-100	24546	C4-1/8-T0-1002-F
A31R141	0757-0442	9		RESISTOR 10K 1% .125W F TC=0+-100	24546	C4-1/8-T0-1002-F
A31R142	0757-0442	9		RESISTOR 10K 1% .125W F TC=0+-100	24546	C4-1/8-T0-1002-F
A31R143	0757-0199	3		RESISTOR 21.5K 1% .125W F TC=0+-100	24546	C4-1/8-T0-2152-F
A31R144	0757-0199	3		RESISTOR 21.5K 1% .125W F TC=0+-100	24546	C4-1/8-T0-2152-F
A31R145	0698-3438	3		RESISTOR 147 1% .125W F TC=0+-100	24546	C4-1/8-T0-147R-F
A31R146	0757-0421			RESISTOR 825 1% .125W F TC=0+-100	24546	
A31T1	9100-0823	8	1	TRANSFORMER(TDK113B1) 1:1:1	28480	9100-0823
A31T2	9100-4452	7	1	PULSE TRANSFORMER 112C1	28480	9100-4452
A31TP1	0360-0535	0	10	TERMINAL TEST POINT PCB	00000	ORDER BY DESCRIPT.
A31TP2	0360-0535	0		TERMINAL TEST POINT PCB	00000	ORDER BY DESCRIPT.
A31TP3	0360-0535	0		TERMINAL TEST POINT PCB	00000	ORDER BY DESCRIPT.
A31TP4	0360-0535	0		TERMINAL TEST POINT PCB	00000	ORDER BY DESCRIPT.
A31TP5	0360-0535	0		TERMINAL TEST POINT PCB	00000	ORDER BY DESCRIPT.
A31TP6	0360-0535	0		TERMINAL TEST POINT PCB	00000	ORDER BY DESCRIPT.
A31TP7	0360-0535	0		TERMINAL TEST POINT PCB	00000	ORDER BY DESCRIPT.
A31TP8	0360-0535	0		TERMINAL TEST POINT PCB	00000	ORDER BY DESCRIPT.
A31TP9	0360-0535	0		TERMINAL TEST POINT PCB	00000	ORDER BY DESCRIPT.
A31TP10	0360-0535	0		TERMINAL TEST POINT PCB	00000	ORDER BY DESCRIPT.
A31U1	1820-1730	6	1	IC FF TTL LS D-TYPE POS-EDGE-TRIG COM	01295	SN74LS273N

See introduction to this section for ordering information.
 * Indicates factory selected value.

Table 6-3. Replaceable Parts (continued)

Reference Designator	HP Part Number	C D	Qty.	Description	Mfr Code	Mfr Part Number
A31U2	1820-1433	6	1	IC SHF-RGTR TTL LS R-S SERIAL-IN PRL-OUT	01295	SN74LS164N
A31U3	1820-1199	1	1	IC INV TTL LS HEX 1-INP	01295	SN74LS04N
A31U4	1820-1112	8	2	IC FF TTL LS D-TYPE POS-EDGE-TRIG	01295	SN74LS74AN
A31U5	1820-1112	8		IC FF TTL LS D-TYPE POS-EDGE-TRIG	01295	SN74LS74AN
A31U6	1820-1144	6	1	IC GATE TTL LS NOR QUAD 2-INP	01295	SN74LS02N
A31U7	1820-1202	7	2	IC GATE TTL LS NAND TPL 3-INP	01295	SN74LS10N
A31U8	1820-1202	7		IC GATE TTL LS NAND TPL 3-INP	01295	SN74LS10N
A31U9	1826-0065	0	1	IC COMPARATOR PRCN 8-DIP-P PKG	S0545	UPC311C
A31U10	1826-0783	9	2	IC OP AMP LOW-NOISE 8-DIP-C PKG	52063	XR5534ACN
A31U11	1826-0138	8	1	IC COMPARATOR GP QUAD 14-DIP-P PKG	01295	LM339N
A31U12	1826-0412	1	2	IC COMPARATOR PRCN DUAL 8-DIP-P PKG	27014	LM393N
A31U13	1826-0081	0	1	IC OP AMP WB TO-99 PKG	27014	LM318H
A31U14	1826-0783	9		IC OP AMP LOW-NOISE 8-DIP-C PKG	52063	XR5534ACN
A31U15	1820-0430	1	1	IC 309 V RGLTR TO-3	07263	LM309K
A31U16	1826-0147	9	3	IC 7812 V RGLTR TO-220	04713	MC7812CP
A31U17	1826-0221	0	4	IC V RGLTR TO-220	04713	MC7912CT
A31U18	1826-1316	6	1	IC OP AMP LOW-NOISE 8-DIP-C PKG	28480	1826-1316
A31U19	1826-0412	1		IC COMPARATOR PRCN DUAL 8-DIP-P PKG	27014	LM393N
A31U20	1826-0147	9		IC 7812 V RGLTR TO-220	04713	MC7812CP
A31U21	1826-0221	0		IC V RGLTR TO-220	04713	MC7912CT
A31U22	1826-0221	0		IC V RGLTR TO-220	04713	MC7912CT
A31U23	1826-0147	9		IC 7812 V RGLTR TO-220	04713	MC7812CP
A31U24	1826-0221	0		IC V RGLTR TO-220	04713	MC7912CT
A31U25	04194-81801	6	2	HIC MPX G-P	28480	04194-81801
A31U26	04194-81801	6		HIC MPX G-P	28480	04194-81801
A31W1	1258-0141			JUMPER-REM	28480	1258-0141
A31W2	1258-0141			JUMPER-REM	28480	1258-0141
A31W3	1258-0141			JUMPER-REM	28480	1258-0141
A31W4	04194-61691	0	1	CABLE ASSY	28480	04194-61691
A31W5	04194-61692	1	1	CABLE ASSY	28480	04194-61692

See introduction to this section for ordering information.
* Indicates factory selected value.

Table 6-3. Replaceable Parts (continued)

Reference Designator	HP Part Number	C D	Qty.	Description	Mfr Code	Mfr Part Number
A31A1	04194-66571	5	1	TEST CHANNEL AMPLIFIER BOARD ASSEMBLY FOR OPTION 375 UNITS	28480	04194-66571
A31A1C1	0121-0060	0	2	CAPACITOR-V TRMR-CER 2-8PF 350V PC-MTG	52763	304322 2/8PF NPO
A31A1C2	0121-0060	0		CAPACITOR-V TRMR-CER 2-8PF 350V PC-MTG	52763	304322 2/8PF NPO
A31A1C3	0180-1085	5	5	CAPACITOR-FXD 4.7UF 16VDC TA	28480	0180-1085
A31A1C4	0180-1085	5		CAPACITOR-FXD 4.7UF 16VDC TA	28480	0180-1085
A31A1C5	0160-4832	4	13	CAPACITOR-FXD .01UF +-10% 100VDC CER	28480	0160-4832
A31A1C6	0180-3363	6	4	CAPACITOR-FXD 22UF +-20% 25VDC AL	28480	0180-3363
A31A1C7	0180-3363	6		CAPACITOR-FXD 22UF +-20% 25VDC AL	28480	0180-3363
A31A1C8	0160-4833	5	1	CAPACITOR-FXD .022UF +-10% 100VDC CER	28480	0160-4833
A31A1C9	0180-1085	5		CAPACITOR-FXD 4.7UF 16VDC TA	28480	0180-1085
A31A1C10	0160-6423	3	2	CAPACITOR 0.047UF 5%	28480	0160-6423
A31A1C11	0180-1746	5	1	CAPACITOR-FXD 15UF +-10% 20VDC TA	56289	150D156X9020B2
A31A1C12	0160-4832	4		CAPACITOR-FXD .01UF +-10% 100VDC CER	28480	0160-4832
A31A1C13	0160-4810	8	2	CAPACITOR-FXD 330PF +-5% 100VDC CER	28480	0160-4810
A31A1C14	0180-3469	3	4	CAPACITOR-FXD 100UF +-20% 25VDC AL	28480	0180-3469
A31A1C15	0160-4795	8	2	CAPACITOR-FXD 4.7PF +- .5PF 100VDC CER	28480	0160-4795
A31A1C16	0180-1085	5		CAPACITOR-FXD 4.7UF 16VDC TA	28480	0180-1085
A31A1C17	0160-4810	8		CAPACITOR-FXD 330PF +-5% 100VDC CER	28480	0160-4810
A31A1C18	0180-3469	3		CAPACITOR-FXD 100UF +-20% 25VDC AL	28480	0180-3469
A31A1C19	0180-3469	3		CAPACITOR-FXD 100UF +-20% 25VDC AL	28480	0180-3469
A31A1C20	0160-4795	8		CAPACITOR-FXD 4.7PF +- .5PF 100VDC CER	28480	0160-4795
A31A1C21	0160-4832	4		CAPACITOR-FXD .01UF +-10% 100VDC CER	28480	0160-4832
A31A1C22	0160-4832	4		CAPACITOR-FXD .01UF +-10% 100VDC CER	28480	0160-4832
A31A1C23	0180-3469	3		CAPACITOR-FXD 100UF +-20% 25VDC AL	28480	0180-3469
A31A1C24	0180-0229	7		CAPACITOR-FXD 33UF TA		
A31A1C25	0180-3363	6		CAPACITOR-FXD 22UF +-20% 25VDC AL	28480	0180-3363
A31A1C26	0180-3363	6		CAPACITOR-FXD 22UF +-20% 25VDC AL	28480	0180-3363
A31A1C27	0160-4832	4		CAPACITOR-FXD .01UF +-10% 100VDC CER	28480	0160-4832
A31A1C28				NOT ASSIGNED		
A31A1C29	0180-3469	3		CAPACITOR-FXD 100UF +-20% 25VDC AL	28480	0180-3469
A31A1C30				NOT ASSIGNED		
A31A1C31	0160-4832	4		CAPACITOR-FXD .01UF +-10% 100VDC CER	28480	0160-4832
A31A1C32	0160-4832	4		CAPACITOR-FXD .01UF +-10% 100VDC CER	28480	0160-4832
A31A1C33	0160-4789	0	1	CAPACITOR-FXD 15PF +-5% 100VDC CER 0+-30	28480	0160-4789
A31A1C34	0160-4799	2	1	CAPACITOR-FXD 2.2PF +- .25PF 100VDC CER	28480	0160-4799
A31A1C35	0160-4832	4		CAPACITOR-FXD .01UF +-10% 100VDC CER	28480	0160-4832
A31A1C36				NOT ASSIGNED		
A31A1C37				NOT ASSIGNED		
A31A1C38	0160-4801	7	2	CAPACITOR-FXD 100PF +-5% 100VDC CER	28480	0160-4801
A31A1C39	0160-4801	7		CAPACITOR-FXD 100PF +-5% 100VDC CER	28480	0160-4801
A31A1C40	0160-4832	4		CAPACITOR-FXD .01UF +-10% 100VDC CER	28480	0160-4832
A31A1C41	0160-4832	4		CAPACITOR-FXD .01UF +-10% 100VDC CER	28480	0160-4832
A31A1C42	0180-1085	5		CAPACITOR-FXD 4.7UF 16VDC TA	28480	0180-1085
A31A1C43	0160-6423	3		CAPACITOR 0.047UF 5%	28480	0160-6423
A31A1C44	0160-4832	4		CAPACITOR-FXD .01UF +-10% 100VDC CER	28480	0160-4832
A31A1C45	0160-4832	4		CAPACITOR-FXD .01UF +-10% 100VDC CER	28480	0160-4832
A31A1C46	0160-4832	4		CAPACITOR-FXD .01UF +-10% 100VDC CER	28480	0160-4832

See introduction to this section for ordering information.
 * Indicates factory selected value.

Table 6-3. Replaceable Parts (continued)

Reference Designator	HP Part Number	C D	Qty.	Description	Mfr Code	Mfr Part Number
A31A1CR1	1901-0050	3	8	DIODE-SWITCHING 80V 200MA 2NS DO-35	28480	1901-0050
A31A1CR2	1901-0050	3		DIODE-SWITCHING 80V 200MA 2NS DO-35	28480	1901-0050
A31A1CR3	1901-0050	3		DIODE-SWITCHING 80V 200MA 2NS DO-35	28480	1901-0050
A31A1CR4	1901-0050	3		DIODE-SWITCHING 80V 200MA 2NS DO-35	28480	1901-0050
A31A1CR5	1901-0050	3		DIODE-SWITCHING 80V 200MA 2NS DO-35	28480	1901-0050
A31A1CR6	1901-0050	3		DIODE-SWITCHING 80V 200MA 2NS DO-35	28480	1901-0050
A31A1CR7	1901-0050	3		DIODE-SWITCHING 80V 200MA 2NS DO-35	28480	1901-0050
A31A1CR8	1901-0050	3		DIODE-SWITCHING 80V 200MA 2NS DO-35	28480	1901-0050
A31A1J1	1250-1810	4	2	CONNECTOR-RF SMB M PC-OHM	28480	1250-1810
A31A1J2	1250-1810	4		CONNECTOR-RF SMB M PC-OHM	28480	1250-1810
A31A1J3	1251-4683	7	8	CONNECTOR-SGL CONT SKT .04-IN-BSC-SZ RND	28480	1251-4683
A31A1J4	1251-4683	7		CONNECTOR-SGL CONT SKT .04-IN-BSC-SZ RND	28480	1251-4683
A31A1J5	1251-4683	7		CONNECTOR-SGL CONT SKT .04-IN-BSC-SZ RND	28480	1251-4683
A31A1J6	1251-4683	7		CONNECTOR-SGL CONT SKT .04-IN-BSC-SZ RND	28480	1251-4683
A31A1J7	1251-4683	7		CONNECTOR-SGL CONT SKT .04-IN-BSC-SZ RND	28480	1251-4683
A31A1J8	1251-4683	7		CONNECTOR-SGL CONT SKT .04-IN-BSC-SZ RND	28480	1251-4683
A31A1J9	1251-4683	7		CONNECTOR-SGL CONT SKT .04-IN-BSC-SZ RND	28480	1251-4683
A31A1J10	1251-4683	7		CONNECTOR-SGL CONT SKT .04-IN-BSC-SZ RND	28480	1251-4683
A31A1J11	1200-0796	8	1	SOCKET-IC 8-CONT DIP DIP-SLDR	28480	1200-0796
A31A1K1	0490-1485	6	3	RELAY SW	28480	0490-1485
A31A1K2	0490-1485	6		RELAY SW	28480	0490-1485
A31A1K3	0490-1485	6		RELAY SW	28480	0490-1485
A31A1K4	0490-1486	7	2	RELAY-REES	28480	0490-1486
A31A1K5	0490-1486	7		RELAY-REES	28480	0490-1486
A31A1L1	9170-0029	3	6	CORE-SHIELDING BEAD	28480	9170-0029
A31A1L2	9170-0029	3		CORE-SHIELDING BEAD	28480	9170-0029
A31A1L3	9100-2259	8	3	INDUCTOR RF-CH-MLD 1.5UH 10% .105DX.26LG	28480	9100-2259
A31A1L4	9100-2259	8		INDUCTOR RF-CH-MLD 1.5UH 10% .105DX.26LG	28480	9100-2259
A31A1L5	9100-2259	8		INDUCTOR RF-CH-MLD 1.5UH 10% .105DX.26LG	28480	9100-2259
A31A1L6	9170-0029	3		CORE-SHIELDING BEAD	28480	9170-0029
A31A1L7	9170-0029	3		CORE-SHIELDING BEAD	28480	9170-0029
A31A1L8	9170-0029	3		CORE-SHIELDING BEAD	28480	9170-0029
A31A1L9	9170-0029	3		CORE-SHIELDING BEAD	28480	9170-0029
A31A1Q1	1854-1073	1	3	TRANSISTOR NPN SI PD=600MW FT=6.5GHZ	28480	1854-1073
A31A1Q2	1854-1073	1		TRANSISTOR NPN SI PD=600MW FT=6.5GHZ	28480	1854-1073
A31A1Q3	1854-1073	1		TRANSISTOR NPN SI PD=600MW FT=6.5GHZ	28480	1854-1073
A31A1Q4	1855-0081	1	1	TRANSISTOR J-FET N-CHAN D-MODE SI	28480	1855-0081
A31A1R1	0757-0442	9	3	RESISTOR 10K 1% .125W F TC=0+-100	24546	C4-1/8-T0-1002-F
A31A1R2	0757-0442	9		RESISTOR 10K 1% .125W F TC=0+-100	24546	C4-1/8-T0-1002-F
A31A1R3	0757-0442	9		RESISTOR 10K 1% .125W F TC=0+-100	24546	C4-1/8-T0-1002-F
A31A1R4	0698-3430	5	4	RESISTOR 21.5 1% .125W F TC=0+-100	03888	PME55-1/8-T0-21R5-F
A31A1R5	0698-4037	0	2	RESISTOR 46.4 1% .125W F TC=0+-100	24546	C4-1/8-T0-46R4-F
A31A1R6	0698-0084	9	2	RESISTOR 2.15K 1% .125W F TC=0+-100	24546	C4-1/8-T0-2151-F
A31A1R7	0757-0280	3	2	RESISTOR 1K 1% .125W F TC=0+-100	24546	C4-1/8-T0-1001-F
A31A1R8	0757-0277	8	5	RESISTOR 49.9 1% .125W F TC=0+-100	24546	C4-1/8-T0-4992-F
A31A1R9	0757-0279	0	3	RESISTOR 3.16K 1% .125W F TC=0+-100	24546	C4-1/8-T0-3161-F
A31A1R10	0698-3155	1	2	RESISTOR 4.64K 1% .125W F TC=0+-100	24546	C4-1/8-T0-4641-F
A31A1R11	0757-0440	7	3	RESISTOR 7.5K 1% .125W F TC=0+-100	24546	C4-1/8-T0-7501-F
A31A1R12	0757-0421	4	2	RESISTOR 825 1% .125W F TC=0+-100	24546	C4-1/8-T0-825R-F

See introduction to this section for ordering information.
* Indicates factory selected value.

Table 6-3. Replaceable Parts (continued)

Reference Designator	HP Part Number	C D	Qty.	Description	Mfr Code	Mfr Part Number
A31A1R13	0757-0279	0		RESISTOR 3.16K 1% .125W F TC=0+-100	24546	C4-1/8-T0-3161-F
A31A1R14	0757-0440	7		RESISTOR 7.5K 1% .125W F TC=0+-100	24546	C4-1/8-T0-7501-F
A31A1R15	0757-0402	1	1	RESISTOR 110 1% .125W F TC=0+-100	24546	C4-1/8-T0-111-F
A31A1R16	0757-0280	3		RESISTOR 1K 1% .125W F TC=0+-100	24546	C4-1/8-T0-1001-F
A31A1R17	0698-3444	1	1	RESISTOR 316 1% .125W F TC=0+-100	24546	C4-1/8-T0-316R-F
A31A1R18	0757-0180	2	1	RESISTOR 31.6 1% .125W F TC=0+-100	28480	0757-0180
A31A1R19	0698-3438	3	2	RESISTOR 147 1% .125W F TC=0+-100	24546	C4-1/8-T0-147R-F
A31A1R20	0757-0277	8		RESISTOR 49.9 1% .125W F TC=0+-100	24546	C4-1/8-T0-4992-F
A31A1R21	0757-0277	8		RESISTOR 49.9 1% .125W F TC=0+-100	24546	C4-1/8-T0-4992-F
A31A1R22	0698-3155	1		RESISTOR 4.64K 1% .125W F TC=0+-100	24546	C4-1/8-T0-4641-F
A31A1R23	0757-0440	7		RESISTOR 7.5K 1% .125W F TC=0+-100	24546	C4-1/8-T0-7501-F
A31A1R24	0757-0277	8		RESISTOR 49.9 1% .125W F TC=0+-100	24546	C4-1/8-T0-4992-F
A31A1R25	0757-0277	8		RESISTOR 49.9 1% .125W F TC=0+-100	24546	C4-1/8-T0-4992-F
A31A1R26	0757-0438	3	3	RESISTOR 5.11K 1% .125W F TC=0+-100	24546	C4-1/8-T0-5111-F
A31A1R27	0698-3430	5		RESISTOR 21.5 1% .125W F TC=0+-100	03888	PME55-1/8-T0-21R5-F
A31A1R28	0698-3155	1		RESISTOR 4.64K 1% .125W F TC=0+-100	24546	C4-1/8-T0-4641-F
A31A1R29	0757-0440	7		RESISTOR 7.5K 1% .125W F TC=0+-100	24546	C4-1/8-T0-7501-F
A31A1R30	2100-3091	1	1	RESISTOR-TRMR 2K 10% C TOP-ADJ 17-TRM	32997	3292W-1-202
A31A1R31	0698-3154	0	2	RESISTOR 4.22K 1% .125W F TC=0+-100	24546	C4-1/8-T0-4221-F
A31A1R32	0698-3154	0		RESISTOR 4.22K 1% .125W F TC=0+-100	24546	C4-1/8-T0-4221-F
A31A1R33	0757-0397	3	1	RESISTOR 68.1 1% .125W F TC=0+-100	24546	C4-1/8-T0-68R1-F
A31A1R34	0698-3438	3		RESISTOR 147 1% .125W F TC=0+-100	24546	C4-1/8-T0-147R-F
A31A1R35	0698-3430	5		RESISTOR 21.5 1% .125W F TC=0+-100	03888	PME55-1/8-T0-21R5-F
A31A1R36	0757-0420	3		RESISTOR 750		
A31A1R37	0698-0084	9		RESISTOR 2.15K 1% .125W F TC=0+-100	24546	C4-1/8-T0-2151-F
A31A1R38	0698-3430	5		RESISTOR 21.5 1% .125W F TC=0+-100	03888	PME55-1/8-T0-21R5-F
A31A1R39	0757-0280	3		RESISTOR 1.0K		
A31A1R40	0699-1814	7	1	RESISTOR 76.18		
A31A1R41	0757-0421	4		RESISTOR 825 1% .125W F TC=0+-100	24546	C4-1/8-T0-825R-F
A31A1R42	0698-8525	3	2	RESISTOR		0698-8525
A31A1R43	0698-3159	5	1	RESISTOR 26.1K 1% .125W F TC=0+-100	24546	C4-1/8-T0-2612-F
A31A1R44	0698-3160	8	1	RESISTOR 31.6K 1% .125W F TC=0+-100	24546	C4-1/8-T0-3162-F
A31A1R45	0757-0441	8	1	RESISTOR 8.25K 1% .125W F TC=0+-100	24546	C4-1/8-T0-8251-F
A31A1R46	0757-0466	7	1	RESISTOR 110K 1% .125W F TC=0+-100	24546	C4-1/8-T0-1103-F
A31A1R47	0757-0379	1	2	RESISTOR 12.1 1% .125W F TC=0+-100	19701	MF4C1/8-T0-12R1-F
A31A1R48	0698-8827	4	1	RESISTOR 1M 1% .125W F TC=0+-100	28480	0698-8827
A31A1R49	0699-1816	9	2	RESISTOR 267.8		
A31A1R50	0699-1815	8		RESISTOR 45.6		
A31A1R51	0699-1816	9		RESISTOR 267.8		
A31A1R52	0698-8525	9		RESISTOR 91.67 .1% .125W F TC=0+-50	28480	0698-8525
A31A1R53	0698-8526	0	1	RESISTOR 371.25 .1% .125W F TC=0+-50	28480	0698-8526
A31A1R54	0757-0467	8	2	RESISTOR 121K 1% .125W F TC=0+-100	24546	C4-1/8-T0-1213-F
A31A1R55	0698-8961	7	1	RESISTOR 909K 1% .125W F TC=0+-100	28480	0698-8961
A31A1R56	0757-0199	3	1	RESISTOR 21.5K 1% .125W F TC=0+-100	24546	C4-1/8-T0-2152-F
A31A1R57	0757-0438	3	2	RESISTOR 5.11K 1% .125W F TC=0+-100	24546	C4-1/8-T0-5111-F
A31A1R58	0757-0438	3		RESISTOR 5.11K 1% .125W F TC=0+-100	24546	C4-1/8-T0-5111-F
A31A1R59	0757-0467	8		RESISTOR 121K 1% .125W F TC=0+-100	24546	C4-1/8-T0-1213-F
A31A1R60	0757-0379	1		RESISTOR 12.1 1% .125W F TC=0+-100	19701	MF4C1/8-T0-12R1-F
A31A1R61	0683-2255	9	2	RESISTOR 2.2M 5% .25W FC TC=-900/+1100	01121	CB2255

See introduction to this section for ordering information.
 * Indicates factory selected value.

Table 6-3. Replaceable Parts (continued)

Reference Designator	HP Part Number	C D	Qty.	Description	Mfr Code	Mfr Part Number
A31A1R62	0698-3459	8	2	RESISTOR 383K 1% .125W F TC=0+-100	28480	0698-3459
A31A1R63	0683-2255	9		RESISTOR 2.2M 5% .25W FC TC=-900/+1100	01121	CB2255
A31A1R64	0698-3459	8		RESISTOR 383K 1% .125W F TC=0+-100	28480	0698-3459
A31A1R65	0757-0438	3		RESISTOR 1.62K 1% .125W F TC=0+-100	24546	C4-1/8-T0-1621-F
A31A1TP1	0360-0535	0	1	TERMINAL TEST POINT PCB	00000	ORDER BY DESCRIPT.
A31A1U1	1858-0047	5	1	TRANSISTOR ARRAY 16-PIN PLSTC DIP	13606	ULN-2003A
A31A1U2	1826-1317	7	1	IC OP AMP LOW-NOISE 8-DIP-P PKG	28480	1826-1317
A31A1U3	1826-0521	3	1	IC OP AMP LOW-BIAS-H-IMPED DUAL 8-DIP-P	01295	TL072CP

See introduction to this section for ordering information.
 * Indicates factory selected value.

Table 6-3. Replaceable Parts (continued)

Reference Designator	HP Part Number	C D	Qty.	Description	Mfr Code	Mfr Part Number
A31A2	04194-66572	2	1	REFERENCE CHANNEL AMPLIFIER BOARD ASSEMBLY FOR OPTION 375 UNITS	28480	04194-66552
A31A2C1	0121-0060	0	2	CAPACITOR-V TRMR-CER 2-8PF 350V PC-MTG	52763	304322 2/8PF NPO
A31A2C2	0121-0060	0		CAPACITOR-V TRMR-CER 2-8PF 350V PC-MTG	52763	304322 2/8PF NPO
A31A2C3	0160-4832	4	3	CAPACITOR-FXD .01UF +-10% 100VDC CER	28480	0160-4832
A31A2C4	0160-4810	8	2	CAPACITOR-FXD 330PF +-5% 100VDC CER	28480	0160-4810
A31A2C5	0180-1746	5	1	CAPACITOR-FXD 15UF +-10% 20VDC TA	56289	150D156X9020B2
A31A2C6	0160-6423	3	2	CAPACITOR 0.047UF 5%	28480	0160-6423
A31A2C7	0180-1085	5	5	CAPACITOR-FXD 4.7UF 16VDC TA	28480	0180-1085
A31A2C8	0180-1085	5		CAPACITOR-FXD 4.7UF 16VDC TA	28480	0180-1085
A31A2C9	0160-4833	5	1	CAPACITOR-FXD .022UF +-10% 100VDC CER	28480	0160-4833
A31A2C10	0180-3363	6	4	CAPACITOR-FXD 22UF +-20% 25VDC AL	28480	0180-3363
A31A2C11	0180-3363	6		CAPACITOR-FXD 22UF +-20% 25VDC AL	28480	0180-3363
A31A2C12	0160-4832	4		CAPACITOR-FXD .01UF +-10% 100VDC CER	28480	0160-4832
A31A2C13	0180-1085	5		CAPACITOR-FXD 4.7UF 16VDC TA	28480	0180-1085
A31A2C14	0160-4832	4		CAPACITOR-FXD .01UF +-10% 100VDC CER	28480	0160-4832
A31A2C15	0160-4810	8		CAPACITOR-FXD 330PF +-5% 100VDC CER	28480	0160-4810
A31A2C16	0180-1085	5		CAPACITOR-FXD 4.7UF 16VDC TA	28480	0180-1085
A31A2C17	0160-4795	8	2	CAPACITOR-FXD 4.7PF +- .5PF 100VDC CER	28480	0160-4795
A31A2C18	0160-4832	4		CAPACITOR-FXD .01UF +-10% 100VDC CER	28480	0160-4832
A31A2C19	0160-4795	8		CAPACITOR-FXD 4.7PF +- .5PF 100VDC CER	28480	0160-4795
A31A2C20	0180-3469	3	4	CAPACITOR-FXD 100UF +-20% 25VDC AL	28480	0180-3469
A31A2C21				NOT ASSIGNED		
A31A2C22	0180-3469	3		CAPACITOR-FXD 100UF +-20% 25VDC AL	28480	0180-3469
A31A2C23	0160-4832	4		CAPACITOR-FXD .01UF +-10% 100VDC CER	28480	0160-4832
A31A2C24	0180-3469	3		CAPACITOR-FXD 100UF +-20% 25VDC AL	28480	0180-3469
A31A2C25				NOT ASSIGNED		
A31A2C26	0160-4832	4		CAPACITOR-FXD .01UF +-10% 100VDC CER	28480	0160-4832
A31A2C27	0180-3363	6		CAPACITOR-FXD 22UF +-20% 25VDC AL	28480	0180-3363
A31A2C28	0180-3363	6		CAPACITOR-FXD 22UF +-20% 25VDC AL	28480	0180-3363
A31A2C29	0180-0229	7		CAPACITOR-FXD 33UF TA		
A31A2C30	0180-3469	3		CAPACITOR-FXD 100UF +-20% 25VDC AL	28480	0180-3469
A31A2C31	0180-3469	3		CAPACITOR-FXD 100UF +-20% 25VDC AL	28480	0180-3469
A31A2C32	0160-4801	7	2	CAPACITOR-FXD 100PF +-5% 100VDC CER	28480	0160-4801
A31A2C33	0160-4801	7		CAPACITOR-FXD 100PF +-5% 100VDC CER	28480	0160-4801
A31A2C34	0160-4832	4		CAPACITOR-FXD .01UF +-10% 100VDC CER	28480	0160-4832
A31A2C35				NOT ASSIGNED		
A31A2C36				NOT ASSIGNED		
A31A2C37	0160-4832	4		CAPACITOR-FXD .01UF +-10% 100VDC CER	28480	0160-4832
A31A2C38	0160-4789	0	1	CAPACITOR-FXD 15PF +-5% 100VDC CER 0+-30	28480	0160-4789
A31A2C39	0160-4832	4		CAPACITOR-FXD .01UF +-10% 100VDC CER	28480	0160-4832
A31A2C40	0160-4832	4		CAPACITOR-FXD .01UF +-10% 100VDC CER	28480	0160-4832
A31A2C41	0160-4832	4		CAPACITOR-FXD .01UF +-10% 100VDC CER	28480	0160-4832
A31A2C42	0160-4832	4		CAPACITOR-FXD .01UF +-10% 100VDC CER	28480	0160-4832
A31A2C43	0180-1085	5		CAPACITOR-FXD 4.7UF 16VDC TA	28480	0180-1085
A31A2C44	0160-6423	3		CAPACITOR 0.047UF 5%	28480	0160-6423
A31A2C45	0160-4832	4		CAPACITOR-FXD .01UF +-10% 100VDC CER	28480	0160-4832
A31A2C46	0160-4799	2		CAPACITOR-FXD 2.2PF +- .25PF 100VDC CER	28480	0160-4799

See introduction to this section for ordering information.
* Indicates factory selected value.

Table 6-3. Replaceable Parts (continued)

Reference Designator	HP Part Number	C D	Qty.	Description	Mfr Code	Mfr Part Number
A31A2CR1	1901-0050	3	8	DIODE-SWITCHING 80V 200MA 2NS DO-35	28480	1901-0050
A31A2CR2	1901-0050	3		DIODE-SWITCHING 80V 200MA 2NS DO-35	28480	1901-0050
A31A2CR3	1901-0050	3		DIODE-SWITCHING 80V 200MA 2NS DO-35	28480	1901-0050
A31A2CR4	1901-0050	3		DIODE-SWITCHING 80V 200MA 2NS DO-35	28480	1901-0050
A31A2CR5	1901-0050	3		DIODE-SWITCHING 80V 200MA 2NS DO-35	28480	1901-0050
A31A2CR6	1901-0050	3		DIODE-SWITCHING 80V 200MA 2NS DO-35	28480	1901-0050
A31A2CR7	1901-0050	3		DIODE-SWITCHING 80V 200MA 2NS DO-35	28480	1901-0050
A31A2CR8	1901-0050	3		DIODE-SWITCHING 80V 200MA 2NS DO-35	28480	1901-0050
A31A2J1	1250-1810	4	2	CONNECTOR-RF SMB M PC-OHM	28480	1250-1810
A31A2J2	1250-1810	4		CONNECTOR-RF SMB M PC-OHM	28480	1250-1810
A31A2J3	1251-4683	7	8	CONNECTOR-SGL CONT SKT .04-IN-BSC-SZ RND	28480	1251-4683
A31A2J4	1251-4683	7		CONNECTOR-SGL CONT SKT .04-IN-BSC-SZ RND	28480	1251-4683
A31A2J5	1251-4683	7		CONNECTOR-SGL CONT SKT .04-IN-BSC-SZ RND	28480	1251-4683
A31A2J6	1251-4683	7		CONNECTOR-SGL CONT SKT .04-IN-BSC-SZ RND	28480	1251-4683
A31A2J7	1251-4683	7		CONNECTOR-SGL CONT SKT .04-IN-BSC-SZ RND	28480	1251-4683
A31A2J8	1251-4683	7		CONNECTOR-SGL CONT SKT .04-IN-BSC-SZ RND	28480	1251-4683
A31A2J9	1251-4683	7		CONNECTOR-SGL CONT SKT .04-IN-BSC-SZ RND	28480	1251-4683
A31A2J10	1251-4683	7		CONNECTOR-SGL CONT SKT .04-IN-BSC-SZ RND	28480	1251-4683
A31A2J11	1200-0796	8	1	SOCKET-IC 8-CONT DIP DIP-SLDR	28480	1200-0796
A31A2K1	0490-1485	6	3	RELAY SW	28480	0490-1485
A31A2K2	0490-1485	6		RELAY SW	28480	0490-1485
A31A2K3	0490-1485	6		RELAY SW	28480	0490-1485
A31A2K4	0490-1486	7	2	RELAY-REES	28480	0490-1486
A31A2K5	0490-1486	7		RELAY-REES	28480	0490-1486
A31A2L1	9170-0029	3	6	CORE-SHIELDING BEAD	28480	9170-0029
A31A2L2	9100-2259	8	3	INDUCTOR RF-CH-MLD 1.5UH 10% .105DX.26LG	28480	9100-2259
A31A2L3	9100-2259	8		INDUCTOR RF-CH-MLD 1.5UH 10% .105DX.26LG	28480	9100-2259
A31A2L4	9100-2259	8		INDUCTOR RF-CH-MLD 1.5UH 10% .105DX.26LG	28480	9100-2259
A31A2L5	9170-0029	3		CORE-SHIELDING BEAD	28480	9170-0029
A31A2L6	9170-0029	3		CORE-SHIELDING BEAD	28480	9170-0029
A31A2L7	9170-0029	3		CORE-SHIELDING BEAD	28480	9170-0029
A31A2L8	9170-0029	3		CORE-SHIELDING BEAD	28480	9170-0029
A31A2L9	9170-0029	3		CORE-SHIELDING BEAD	28480	9170-0029
A31A2Q1	1854-1073	1	3	TRANSISTOR NPN SI PD=600MW FT=6.5GHZ	28480	1854-1073
A31A2Q2	1854-1073	1		TRANSISTOR NPN SI PD=600MW FT=6.5GHZ	28480	1854-1073
A31A2Q3	1854-1073	1		TRANSISTOR NPN SI PD=600MW FT=6.5GHZ	28480	1854-1073
A31A2Q4	1855-0081	1	1	TRANSISTOR J-FET N-CHAN D-MODE SI	28480	1855-0081
A31A2R1	0757-0277	8	6	RESISTOR 49.9 1% .125W F TC=0+-100	24546	C4-1/8-T0-4992-F
A31A2R2	0757-0280	3	2	RESISTOR 1K 1% .125W F TC=0+-100	24546	C4-1/8-T0-1001-F
A31A2R3	0698-0084	9	2	RESISTOR 2.15K 1% .125W F TC=0+-100	24546	C4-1/8-T0-2151-F
A31A2R4	0698-4037	0	1	RESISTOR 46.4 1% .125W F TC=0+-100	24546	C4-1/8-T0-46R4-F
A31A2R5	0698-3430	5	4	RESISTOR 21.5 1% .125W F TC=0+-100	03888	PME55-1/8-T0-21R5-F
A31A2R6	0757-0442	9	3	RESISTOR 10K 1% .125W F TC=0+-100	24546	C4-1/8-T0-1002-F
A31A2R7	0757-0442	9		RESISTOR 10K 1% .125W F TC=0+-100	24546	C4-1/8-T0-1002-F
A31A2R8	0757-0442	9		RESISTOR 10K 1% .125W F TC=0+-100	24546	C4-1/8-T0-1002-F
A31A2R9	0757-0280	3		RESISTOR 1K 1% .125W F TC=0+-100	24546	C4-1/8-T0-1001-F
A31A2R10	0698-3444	1	1	RESISTOR 316 1% .125W F TC=0+-100	24546	C4-1/8-T0-316R-F
A31A2R11	0757-0402	1	1	RESISTOR 110 1% .125W F TC=0+-100	24546	C4-1/8-T0-111-F

See introduction to this section for ordering information.
* Indicates factory selected value.

Table 6-3. Replaceable Parts (continued)

Reference Designator	HP Part Number	C D	Qty.	Description	Mfr Code	Mfr Part Number
A31A2R12	0757-0440	7	3	RESISTOR 7.5K 1% .125W F TC=0+-100	24546	C4-1/8-T0-7501-F
A31A2R13	0757-0279	0	3	RESISTOR 3.16K 1% .125W F TC=0+-100	24546	C4-1/8-T0-3161-F
A31A2R14	0757-0421	4	2	RESISTOR 825 1% .125W F TC=0+-100	24546	C4-1/8-T0-825R-F
A31A2R15	0757-0440	7		RESISTOR 7.5K 1% .125W F TC=0+-100	24546	C4-1/8-T0-7501-F
A31A2R16	0698-3155	1	2	RESISTOR 4.64K 1% .125W F TC=0+-100	24546	C4-1/8-T0-4641-F
A31A2R17	0757-0279	0		RESISTOR 3.16K 1% .125W F TC=0+-100	24546	C4-1/8-T0-3161-F
A31A2R18	0698-3159	5	1	RESISTOR 26.1K 1% .125W F TC=0+-100	24546	C4-1/8-T0-2612-F
A31A2R19	0698-3154	0	2	RESISTOR 4.22K 1% .125W F TC=0+-100	24546	C4-1/8-T0-4221-F
A31A2R20	0698-3154	0		RESISTOR 4.22K 1% .125W F TC=0+-100	24546	C4-1/8-T0-4221-F
A31A2R21	2100-3091	1	1	RESISTOR TRMR 2K 10% C TOP-ADJ 17-TRN	32997	3292W-1-202
A31A2R22	0757-0440	7		RESISTOR 7.5K 1% .125W F TC=0+-100	24546	C4-1/8-T0-7501-F
A31A2R23	0698-3155	1		RESISTOR 4.64K 1% .125W F TC=0+-100	24546	C4-1/8-T0-4641-F
A31A2R24	0757-0277	8		RESISTOR 49.9 1% .125W F TC=0+-100	24546	C4-1/8-T0-4992-F
A31A2R25	0757-0277	8		RESISTOR 49.9 1% .125W F TC=0+-100	24546	C4-1/8-T0-4992-F
A31A2R26	0698-3430	5		RESISTOR 21.5 1% .125W F TC=0+-100	03888	PME55-1/8-T0-21R5-F
A31A2R27	0757-0438	3	3	RESISTOR 5.11K 1% .125W F TC=0+-100	24546	C4-1/8-T0-5111-F
A31A2R28	0757-0277	8		RESISTOR 49.9 1% .125W F TC=0+-100	24546	C4-1/8-T0-4992-F
A31A2R29	0757-0277	8		RESISTOR 49.9 1% .125W F TC=0+-100	24546	C4-1/8-T0-4992-F
A31A2R30	0757-0428	1		RESISTOR 1.62K		
A31A2R31	0757-0440	7		RESISTOR 7.5K 1% .125W F TC=0+-100	24546	C4-1/8-T0-7501-F
A31A2R32	0698-3155	1		RESISTOR 4.64K 1% .125W F TC=0+-100	24546	C4-1/8-T0-4641-F
A31A2R33	0698-3438	3	2	RESISTOR 147 1% .125W F TC=0+-100	24546	C4-1/8-T0-147R-F
A31A2R34	0757-0180	2	1	RESISTOR 31.6 1% .125W F TC=0+-100	28480	0757-0180
A31A2R35	0757-0467	8	2	RESISTOR 121K 1% .125W F TC=0+-100	24546	C4-1/8-T0-1213-F
A31A2R36	0698-3152	3		RESISTOR 3.48K 1% .125W F TC=0+-100	24546	C4-1/8-T0-3481-F
A31A2R37	0698-3160	8	1	RESISTOR 31.6K 1% .125W F TC=0+-100	24546	C4-1/8-T0-3162-F
A31A2R38	0757-0441	8	1	RESISTOR 8.25K 1% .125W F TC=0+-100	24546	C4-1/8-T0-8251-F
A31A2R39	0699-1671	4	1	RESISTOR 247.5 .1% .125W F TC=0+-50	28480	0699-1671
A31A2R40	0699-1703	3	2	RESISTOR 61.11 .1% .125W F TC=0+-50	28480	0699-1703
A31A2R41	0757-0421	4		RESISTOR 825 1% .125W F TC=0+-100	24546	C4-1/8-T0-825R-F
A31A2R42	0699-1814	7		RESISTOR 76.18	24546	
A31A2R43	0698-3430	5		RESISTOR 21.5 1% .125W F TC=0+-100	03888	PME55-1/8-T0-21R5-F
A31A2R44	0698-0084	9		RESISTOR 2.15K 1% .125W F TC=0+-100	24546	C4-1/8-T0-2151-F
A31A2R45	0698-3430	5		RESISTOR 21.5 1% .125W F TC=0+-100	03888	PME55-1/8-T0-21R5-F
A31A2R46	0757-0420	3		RESISTOR 750		
A31A2R47	0698-3438	3		RESISTOR 147 1% .125W F TC=0+-100	24546	C4-1/8-T0-147R-F
A31A2R48	0757-0397	3	1	RESISTOR 68.1 1% .125W F TC=0+-100	24546	C4-1/8-T0-68R1-F
A31A2R49	0698-3152	3		RESISTOR 3.48K 1% .125W F TC=0+-100	24546	C4-1/8-T0-3481-F
A31A2R50	0757-0467	8		RESISTOR 121K 1% .125W F TC=0+-100	24546	C4-1/8-T0-1213-F
A31A2R51	0757-0199	3	1	RESISTOR 21.5K 1% .125W F TC=0+-100	24546	C4-1/8-T0-2152-F
A31A2R52	0699-1703	3		RESISTOR 61.11 .1% .125W F TC=0+-50	28480	0699-1703
A31A2R53	0699-1816	9	2	RESISTOR 267.8	24546	
A31A2R54	0699-1815	8	1	RESISTOR 45.60	03888	
A31A2R55	0699-1816	9		RESISTOR 267.8	24546	
A31A2R56	0698-8827	4	1	RESISTOR 1M 1% .125W F TC=0+-100	28480	0698-8827
A31A2R57	0757-0379	1	2	RESISTOR 12.1 1% .125W F TC=0+-100	19701	MF4C1/8-T0-12R1-F
A31A2R58	0757-0466	7	1	RESISTOR 110K 1% .125W F TC=0+-100	24546	C4-1/8-T0-1103-F
A31A2R59	0698-8961	7	1	RESISTOR 909K 1% .125W F TC=0+-100	28480	0698-8961
A31A2R60	0698-3459	8	2	RESISTOR 383K 1% .125W F TC=0+-100	28480	0698-3459

See introduction to this section for ordering information.
* Indicates factory selected value.

Table 6-3. Replaceable Parts (continued)

Reference Designator	HP Part Number	C D	Qty.	Description	Mfr Code	Mfr Part Number
A31A2R61	0683-2255	9	2	RESISTOR 2.2M 5% .25W FC TC=-900/+1100	01121	CB2255
A31A2R62	0698-3459	8		RESISTOR 383K 1% .125W F TC=0+-100	28480	0698-3459
A31A2R63	0683-2255	9		RESISTOR 2.2M 5% .25W FC TC=-900/+1100	01121	CB2255
A31A2R64	0757-0379	1		RESISTOR 12.1 1% .125W F TC=0+-100	19701	MF4C1/8-T0-12R1-F
A31A2R65	0757-0280	3		RESISTOR 1.0K		
A31A2TP1	0360-0535	0	1	TERMINAL TEST POINT PCB	00000	ORDER BY DESCRIPT.
A31A2U1	1858-0047	5	1	TRANSISTOR ARRAY 16-PIN PLSTC DIP	13606	ULN-2003A
A31A2U2	1826-1317	7	1	IC OP AMP LOW-NOISE 8-DIP-P PKG	28480	1826-1317
A31A2U3	1826-0521	3	1	IC OP AMP LOW-BIAS-H-IMPED DUAL 8-DIP-P	01295	TL072CP

See introduction to this section for ordering information.
 * Indicates factory selected value.

Table 6-3. Replaceable Parts (continued)

Reference Designator	HP Part Number	C D	Qty.	Description	Mfr Code	Mfr Part Number
A34	04194-66534	8	1	OUTPUT AMPLIFIER BOARD ASSEMBLY FOR OPTION 375 UNITS	28480	04194-66524
A34A1	04194-66573	7	1	PWR SPLTR BD ASSY	28480	04194-66573
A34C1	0160-4835	7	3	CAPACITOR-FXD .1UF +-10% 50VDC CER	28480	0160-4835
A34C2	0180-3469	3	8	CAPACITOR-FXD 100UF +-20% 25VDC AL	28480	0180-3469
A34C3	0180-3469	3		CAPACITOR-FXD 100UF +-20% 25VDC AL	28480	0180-3469
A34C4	0160-4835	7		CAPACITOR-FXD .1UF +-10% 50VDC CER	28480	0160-4835
A34C5	0160-4835	7		CAPACITOR-FXD .1UF +-10% 50VDC CER	28480	0160-4835
A34C6	0180-3469	3		CAPACITOR-FXD 100UF +-20% 25VDC AL	28480	0180-3469
A34C7	0180-3469	3		CAPACITOR-FXD 100UF +-20% 25VDC AL	28480	0180-3469
A34C8	0180-3469	3		CAPACITOR-FXD 100UF +-20% 25VDC AL	28480	0180-3469
A34C9	0180-3469	3		CAPACITOR-FXD 100UF +-20% 25VDC AL	28480	0180-3469
A34C10	0160-4832	4	30	CAPACITOR-FXD .01UF +-10% 100VDC CER	28480	0160-4832
A34C11	0180-3593	4	4	CAPACITOR-FXD 330UF +-20% 25VDC AL	28480	0180-3593
A34C12	0180-3363	6	25	CAPACITOR-FXD 22UF +-20% 25VDC AL	28480	0180-3363
A34C13	0180-3363	6		CAPACITOR-FXD 22UF +-20% 25VDC AL	28480	0180-3363
A34C14	0160-4832	4		CAPACITOR-FXD .01UF +-10% 100VDC CER	28480	0160-4832
A34C15	0160-2237	9	2	CAPACITOR-FXD 1.2PF +- .25PF 500VDC CER	28480	0160-2237
A34C16	0180-3363	6		CAPACITOR-FXD 22UF +-20% 25VDC AL	28480	0180-3363
A34C17	0160-4832	4		CAPACITOR-FXD .01UF +-10% 100VDC CER	28480	0160-4832
A34C18	0180-3363	6		CAPACITOR-FXD 22UF +-20% 25VDC AL	28480	0180-3363
A34C19	0160-4786	7	2	CAPACITOR-FXD 27PF +-5% 100VDC CER 0+-30	28480	0160-4786
A34C20	0160-4805	1	1	CAPACITOR-FXD 47PF +-5% 100VDC CER 0+-30	28480	0160-4805
A34C21	0160-4786	7		CAPACITOR-FXD 27PF +-5% 100VDC CER 0+-30	28480	0160-4786
A34C22	0160-4801	7	2	CAPACITOR-FXD 100PF +-5% 100VDC CER	28480	0160-4801
A34C23	0160-4803	9	2	CAPACITOR-FXD 68PF +-5% 100VDC CER 0+-30	28480	0160-4803
A34C24	0160-4800	6	1	CAPACITOR-FXD 120PF +-5% 100VDC CER	28480	0160-4800
A34C25	0160-4803	9		CAPACITOR-FXD 68PF +-5% 100VDC CER 0+-30	28480	0160-4803
A34C26	0180-3363	6		CAPACITOR-FXD 22UF +-20% 25VDC AL	28480	0180-3363
A34C27	0160-4832	4		CAPACITOR-FXD .01UF +-10% 100VDC CER	28480	0160-4832
A34C28	0180-3363	6		CAPACITOR-FXD 22UF +-20% 25VDC AL	28480	0180-3363
A34C29	0180-3363	6		CAPACITOR-FXD 22UF +-20% 25VDC AL	28480	0180-3363
A34C30	0160-2237	9		CAPACITOR-FXD 1.2PF +- .25PF 500VDC CER	28480	0160-2237
A34C31	0160-4832	4		CAPACITOR-FXD .01UF +-10% 100VDC CER	28480	0160-4832
A34C32	0180-3363	6		CAPACITOR-FXD 22UF +-20% 25VDC AL	28480	0180-3363
A34C33	0180-3363	6		CAPACITOR-FXD 22UF +-20% 25VDC AL	28480	0180-3363
A34C34	0160-4832	4		CAPACITOR-FXD .01UF +-10% 100VDC CER	28480	0160-4832
A34C35	0180-3363	6		CAPACITOR-FXD 22UF +-20% 25VDC AL	28480	0180-3363
A34C36	0180-3363	6		CAPACITOR-FXD 22UF +-20% 25VDC AL	28480	0180-3363
A34C37	0160-4832	4		CAPACITOR-FXD .01UF +-10% 100VDC CER	28480	0160-4832
A34C38	0180-3363	6		CAPACITOR-FXD 22UF +-20% 25VDC AL	28480	0180-3363
A34C39	0180-3363	6		CAPACITOR-FXD 22UF +-20% 25VDC AL	28480	0180-3363
A34C40	0180-3363	6		CAPACITOR-FXD 22UF +-20% 25VDC AL	28480	0180-3363
A34C41	0160-4832	4		CAPACITOR-FXD .01UF +-10% 100VDC CER	28480	0160-4832
A34C42	0160-4832	4		CAPACITOR-FXD 0.01UF +-10% 100VDC CER	28480	0160-4832
A34C43	0160-4832	4		CAPACITOR-FXD .01UF +-10% 100VDC CER	28480	0160-4832
A34C44	0180-3363	6		CAPACITOR-FXD 22UF +-20% 25VDC AL	28480	0180-3363
A34C45	0180-3363	6		CAPACITOR-FXD 22UF +-20% 25VDC AL	28480	0180-3363

See introduction to this section for ordering information.
* Indicates factory selected value.

Table 6-3. Replaceable Parts (continued)

Reference Designator	HP Part Number	C D	Qty.	Description	Mfr Code	Mfr Part Number
A34C46	0180-3363	6		CAPACITOR-FXD 22UF +-20% 25VDC AL	28480	0180-3363
A34C47	0180-3363	6		CAPACITOR-FXD 22UF +-20% 25VDC AL	28480	0180-3363
A34C48	0180-3363	6		CAPACITOR-FXD 22UF +-20% 25VDC AL	28480	0180-3363
A34C49	0160-4832	4		CAPACITOR-FXD .01UF +-10% 100VDC CER	28480	0160-4832
A34C50	0160-4832	4		CAPACITOR-FXD .01UF +-10% 100VDC CER	28480	0160-4832
A34C51	0180-3596	7	3	CAPACITOR-FXD 100UF +-20% 100VDC AL	28480	0180-3596
A34C52	0160-4832	4		CAPACITOR-FXD .01UF +-10% 100VDC CER	28480	0160-4832
A34C53	0160-4832	4		CAPACITOR-FXD .01UF +-10% 100VDC CER	28480	0160-4832
A34C54	0160-4832	4		CAPACITOR-FXD .01UF +-10% 100VDC CER	28480	0160-4832
A34C55	0160-4832	4		CAPACITOR-FXD .01UF +-10% 100VDC CER	28480	0160-4832
A34C56	0180-3469	3		CAPACITOR-FXD 100UF +-20% 25VDC AL	28480	0180-3469
A34C57	0180-3593	4		CAPACITOR-FXD 330UF +-20% 25VDC AL	28480	0180-3593
A34C58	0180-3469	3		CAPACITOR-FXD 100UF +-20% 25VDC AL	28480	0180-3469
A34C59	0160-4832	4		CAPACITOR-FXD .01UF +-10% 100VDC CER	28480	0160-4832
A34C60	0160-4801	7		CAPACITOR-FXD 100PF +-5% 100VDC CER	28480	0160-4801
A34C61	0160-4832	4		CAPACITOR-FXD .01UF +-10% 100VDC CER	28480	0160-4832
A34C62	0160-4832	4		CAPACITOR-FXD .01UF +-10% 100VDC CER	28480	0160-4832
A34C63	0160-4832	4		CAPACITOR-FXD .01UF +-10% 100VDC CER	28480	0160-4832
A34C64	0160-4808	4	2	CAPACITOR-FXD 470PF +-5% 100VDC CER	28480	0160-4808
A34C65	0180-3363	6		CAPACITOR-FXD 22UF +-20% 25VDC AL	28480	0180-3363
A34C66	0180-3596	7		CAPACITOR-FXD 100UF +-20% 100VDC AL	28480	0180-3596
A34C67	0180-3431	9	2	CAPACITOR-FXD 220UF +-20% 10VDC AL	28480	0180-3431
A34C68	0180-3431	9		CAPACITOR-FXD 220UF +-20% 10VDC AL	28480	0180-3431
A34C69	0160-4832	4		CAPACITOR-FXD .01UF +-10% 100VDC CER	28480	0160-4832
A34C70	0180-3593	4		CAPACITOR-FXD 330UF +-20% 25VDC AL	28480	0180-3593
A34C71	0180-3593	4		CAPACITOR-FXD 330UF +-20% 25VDC AL	28480	0180-3593
A34C72	0180-3363	6		CAPACITOR-FXD 22UF +-20% 25VDC AL	28480	0180-3363
A34C73	0180-3596	7		CAPACITOR-FXD 100UF +-20% 100VDC AL	28480	0180-3596
A34C74	0180-3363	6		CAPACITOR-FXD 22UF +-20% 25VDC AL	28480	0180-3363
A34C75	0180-3363	6		CAPACITOR-FXD 22UF +-20% 25VDC AL	28480	0180-3363
A34C76	0160-4808	4		CAPACITOR-FXD 470PF +-5% 100VDC CER	28480	0160-4808
A34C77	0160-4832	4		CAPACITOR-FXD .01UF +-10% 100VDC CER	28480	0160-4832
A34C78	0160-4832	4		CAPACITOR-FXD .01UF +-10% 100VDC CER	28480	0160-4832
A34C79	0160-4832	4		CAPACITOR-FXD .01UF +-10% 100VDC CER	28480	0160-4832
A34C80	0160-4832	4		CAPACITOR-FXD .01UF +-10% 100VDC CER	28480	0160-4832
A34C81	0180-3471		1	CAPACITOR-FXD 470UF	28480	0180-3471
A34C82	0160-4832	4		CAPACITOR-FXD .01UF +-10% 100VDC CER	28480	0160-4832
A34C83	0160-4832	4		CAPACITOR-FXD .01UF +-10% 100VDC CER	28480	0160-4832
A34C84	0160-6342	5	1	CAPACITOR 1U 100V FILM	28480	0160-6342
A34C85	0180-1085	5	1	CAPACITOR-FXD 4.7UF 16VDC TA	28480	0180-1085
A34C86	0160-4832	4		CAPACITOR-FXD .01UF +-10% 100VDC CER	28480	0160-4832
A34C87	0180-3363	6		CAPACITOR-FXD 22UF +-20% 25VDC AL	28480	0180-3363
A34C88	0180-3363	6		CAPACITOR-FXD 22UF +-20% 25VDC AL	28480	0180-3363
A34C89	0160-4832	4		CAPACITOR-FXD .01UF +-10% 100VDC CER	28480	0160-4832
A34C90	0160-4832	4		CAPACITOR-FXD .01UF +-10% 100VDC CER	28480	0160-4832
A34C91	0160-4813	1		CAPACITOR-FXD 180PF	28480	0160-4813
A34C92				NOT ASSIGNED		
A34CR1	1901-0050	3	32	DIODE-SWITCHING 80V 200MA 2NS DO-35	28480	1901-0050

See introduction to this section for ordering information.
 * Indicates factory selected value.

Table 6-3. Replaceable Parts (continued)

Reference Designator	HP Part Number	C D	Qty.	Description	Mfr Code	Mfr Part Number
A34CR2	1902-0692	1	1	DIODE-ZNR 6.3V 1% DO-7 PD=.4W TC=+.001%	28480	1902-0692
A34CR3	1902-0950	4	1	DIODE-ZNR 4.7V 5% DO-35 PD=.4W TC=+.025%	28480	1902-0950
A34CR4	1901-0050	3		DIODE-SWITCHING 80V 200MA 2NS DO-35	28480	1901-0050
A34CR5	1901-0050	3		DIODE-SWITCHING 80V 200MA 2NS DO-35	28480	1901-0050
A34CR6	1901-0050	3		DIODE-SWITCHING 80V 200MA 2NS DO-35	28480	1901-0050
A34CR7	1901-0050	3		DIODE-SWITCHING 80V 200MA 2NS DO-35	28480	1901-0050
A34CR8	1901-0050	3		DIODE-SWITCHING 80V 200MA 2NS DO-35	28480	1901-0050
A34CR9	1901-0050	3		DIODE-SWITCHING 80V 200MA 2NS DO-35	28480	1901-0050
A34CR10	1901-0050	3		DIODE-SWITCHING 80V 200MA 2NS DO-35	28480	1901-0050
A34CR11	1901-0050	3		DIODE-SWITCHING 80V 200MA 2NS DO-35	28480	1901-0050
A34CR12	1901-0050	3		DIODE-SWITCHING 80V 200MA 2NS DO-35	28480	1901-0050
A34CR13	1901-0050	3		DIODE-SWITCHING 80V 200MA 2NS DO-35	28480	1901-0050
A34CR14	1901-0050	3		DIODE-SWITCHING 80V 200MA 2NS DO-35	28480	1901-0050
A34CR15	1901-0050	3		DIODE-SWITCHING 80V 200MA 2NS DO-35	28480	1901-0050
A34CR16	1901-0050	3		DIODE-SWITCHING 80V 200MA 2NS DO-35	28480	1901-0050
A34CR17	1901-0050	3		DIODE-SWITCHING 80V 200MA 2NS DO-35	28480	1901-0050
A34CR18	1901-0050	3		DIODE-SWITCHING 80V 200MA 2NS DO-35	28480	1901-0050
A34CR19	1901-0050	3		DIODE-SWITCHING 80V 200MA 2NS DO-35	28480	1901-0050
A34CR20	1901-0050	3		DIODE-SWITCHING 80V 200MA 2NS DO-35	28480	1901-0050
A34CR21	1901-0050	3		DIODE-SWITCHING 80V 200MA 2NS DO-35	28480	1901-0050
A34CR22	1901-0050	3		DIODE-SWITCHING 80V 200MA 2NS DO-35	28480	1901-0050
A34CR23	1901-0050	3		DIODE-SWITCHING 80V 200MA 2NS DO-35	28480	1901-0050
A34CR24	1901-0050	3		DIODE-SWITCHING 80V 200MA 2NS DO-35	28480	1901-0050
A34CR25	1901-0050	3		DIODE-SWITCHING 80V 200MA 2NS DO-35	28480	1901-0050
A34CR26	1901-0050	3		DIODE-SWITCHING 80V 200MA 2NS DO-35	28480	1901-0050
A34CR27	1901-0050	3		DIODE-SWITCHING 80V 200MA 2NS DO-35	28480	1901-0050
A34CR28	1901-0050	3		DIODE-SWITCHING 80V 200MA 2NS DO-35	28480	1901-0050
A34CR29				NOT ASSIGNED		
A34CR30	1902-0961	7	2	DIODE-ZNR 13V 5% DO-35 PD=.4W TC=+.082%	28480	1902-0961
A34CR31	1902-0961	7		DIODE-ZNR 13V 5% DO-35 PD=.4W TC=+.082%	28480	1902-0961
A34CR32	1901-0179	7		DIODE-SWITCHING	28480	1901-0179
A34CR33	1901-0179	7		DIODE-SWITCHING	28480	1901-0179
A34CR34	1901-0050	3		DIODE-SWITCHING 80V 200MA 2NS DO-35	28480	1901-0050
A34CR35	1901-0050	3		DIODE-SWITCHING 80V 200MA 2NS DO-35	28480	1901-0050
A34CR36	1901-0050	3		DIODE-SWITCHING 80V 200MA 2NS DO-35	28480	1901-0050
A34CR37	1901-0050	3		DIODE-SWITCHING 80V 200MA 2NS DO-35	28480	1901-0050
A34J1	1200-0541	1	1	SOCKET-IC 24-CONT DIP DIP-SLDR	28480	1200-0541
A34J2	1250-0257	1	2	CONNECTOR-RF SMB M PC 50-OHM	28480	1250-0257
A34J3	0360-0124	3	6	CONNECTOR-SGL CONT PIN .04-IN-BSC-SZ RND	28480	0360-0124
A34J4	0360-0124	3		CONNECTOR-SGL CONT PIN .04-IN-BSC-SZ RND	28480	0360-0124
A34J5	0360-0124	3		CONNECTOR-SGL CONT PIN .04-IN-BSC-SZ RND	28480	0360-0124
A34J6	0360-0124	3		CONNECTOR-SGL CONT PIN .04-IN-BSC-SZ RND	28480	0360-0124
A34J7	0360-0124	3		CONNECTOR-SGL CONT PIN .04-IN-BSC-SZ RND	28480	0360-0124
A34J8	0360-0124	3		CONNECTOR-SGL CONT PIN .04-IN-BSC-SZ RND	28480	0360-0124
A34J9	1250-0257	1		CONNECTOR-RF SMB M PC 50-OHM	28480	1250-0257
A34K1	0490-1485	6	7	RELAY SW	28480	RY5W-OH-K
A34K2	0490-1485	6		RELAY SW	28480	RY5W-OH-K
A34K3	0490-1485	6		RELAY SW	28480	RY5W-OH-K
A34K4	0490-1485	6		RELAY SW	28480	RY5W-OH-K

See introduction to this section for ordering information.
 * Indicates factory selected value.

Table 6-3. Replaceable Parts (continued)

Reference Designator	HP Part Number	C D	Qty.	Description	Mfr Code	Mfr Part Number
A34K5	0490-1485	6		RELAY SW	28480	RY5W-OH-K
A34K6	0490-1485	6		RELAY SW	28480	RY5W-OH-K
A34K7	0490-1485	6		RELAY SW	28480	RY5W-OH-K
A34L1	9140-0114	4	3	INDUCTOR RF-CH-MLD 10UH 10% .166DX.385LG	28480	9140-0114
A34L2	9140-0114	4		INDUCTOR RF-CH-MLD 10UH 10% .166DX.385LG	28480	9140-0114
A34L3	9140-0114	4		INDUCTOR RF-CH-MLD 10UH 10% .166DX.385LG	28480	9140-0114
A34L4	9100-2259	8	16	INDUCTOR RF-CH-MLD 1.5UH 10% .105DX.26LG	28480	9100-2259
A34L5	9100-2259	8		INDUCTOR RF-CH-MLD 1.5UH 10% .105DX.26LG	28480	9100-2259
A34L6	9100-2247	4	3	INDUCTOR RF-CH-MLD 100NH 10% .105DX.26LG	28480	9100-2247
A34L7	9100-2247	4		INDUCTOR RF-CH-MLD 100NH 10% .105DX.26LG	28480	9100-2247
A34L8	9100-2251	0	4	INDUCTOR RF-CH-MLD 220NH 10% .105DX.26LG	28480	9100-2251
A34L9	9100-2251	0		INDUCTOR RF-CH-MLD 220NH 10% .105DX.26LG	28480	9100-2251
A34L10	9100-2259	8		INDUCTOR RF-CH-MLD 1.5UH 10% .105DX.26LG	28480	9100-2259
A34L11	9100-2259	8		INDUCTOR RF-CH-MLD 1.5UH 10% .105DX.26LG	28480	9100-2259
A34L12	9100-2259	8		INDUCTOR RF-CH-MLD 1.5UH 10% .105DX.26LG	28480	9100-2259
A34L13	9100-2259	8		INDUCTOR RF-CH-MLD 1.5UH 10% .105DX.26LG	28480	9100-2259
A34L14	9100-2259	8		INDUCTOR RF-CH-MLD 1.5UH 10% .105DX.26LG	28480	9100-2259
A34L15	9100-2259	8		INDUCTOR RF-CH-MLD 1.5UH 10% .105DX.26LG	28480	9100-2259
A34L16	9100-2259	8		INDUCTOR RF-CH-MLD 1.5UH 10% .105DX.26LG	28480	9100-2259
A34L17	9100-2259	8		INDUCTOR RF-CH-MLD 1.5UH 10% .105DX.26LG	28480	9100-2259
A34L18	9100-2259	8		INDUCTOR RF-CH-MLD 1.5UH 10% .105DX.26LG	28480	9100-2259
A34L19	9100-2259	8		INDUCTOR RF-CH-MLD 1.5UH 10% .105DX.26LG	28480	9100-2259
A34L20	9100-2259	8		INDUCTOR RF-CH-MLD 1.5UH 10% .105DX.26LG	28480	9100-2259
A34L21	9100-2259	8		INDUCTOR RF-CH-MLD 1.5UH 10% .105DX.26LG	28480	9100-2259
A34L22	9100-2251	0		INDUCTOR RF-CH-MLD 220NH 10% .105DX.26LG	28480	9100-2251
A34L23	9100-2247	4		INDUCTOR RF-CH-MLD 100NH 10% .105DX.26LG	28480	9100-2247
A34L24	9100-2259	8		INDUCTOR RF-CH-MLD 1.5UH 10% .105DX.26LG	28480	9100-2259
A34L25	9100-2259	8		INDUCTOR RF-CH-MLD 1.5UH 10% .105DX.26LG	28480	9100-2259
A34L26	9100-1657	8	2	INDUCTOR RF-CH-MLD 1.5MH 5% .23DX.57LG	28480	9100-1657
A34L27	9100-1657	8		INDUCTOR RF-CH-MLD 1.5MH 5% .23DX.57LG	28480	9100-1657
A34L28	9100-2247	4	1	INDUCTOR RF-CH-MLD 100NH	28480	9100-2247
A34Q1	1853-0232	0	3	TRANSISTOR PNP SI TO-39 PD=1W FT=200MHZ	28480	1853-0232
A34Q2	1853-0232	0		TRANSISTOR PNP SI TO-39 PD=1W FT=200MHZ	28480	1853-0232
A34Q3	1853-0232	0		TRANSISTOR PNP SI TO-39 PD=1W FT=200MHZ	28480	1853-0232
A34Q4	1854-0474	4	4	TRANSISTOR NPN SI PD=310MW FT=100MHZ	04713	2N5551
A34Q5	1854-0474	4		TRANSISTOR NPN SI PD=310MW FT=100MHZ	04713	2N5551
A34Q6	1853-0080	6	3	TRANSISTOR PNP SI PD=300MW FT=30MHZ	28480	1853-0080
A34Q7	1854-0474	4		TRANSISTOR NPN SI PD=310MW FT=100MHZ	04713	2N5551
A34Q8	1854-0271	9	4	TRANSISTOR NPN SI TO-39 PD=1W FT=150MHZ	28480	1854-0271
A34Q9	1854-0637	1	1	TRANSISTOR NPN 2N2219A SI TO-5 PD=800MW	01295	2N2219A
A34Q10	1853-0459	3	1	TRANSISTOR PNP SI PD=625MW FT=200MHZ	28480	1853-0459
A34Q11	1854-0597	2	2	TRANSISTOR NPN 2N5943 SI TO-39 PD=1W	04713	2N5943
A34Q12	1854-0271	9		TRANSISTOR NPN SI TO-39 PD=1W FT=150MHZ	28480	1854-0271
A34Q13	1854-0271	9		TRANSISTOR NPN SI TO-39 PD=1W FT=150MHZ	28480	1854-0271
A34Q14	1854-0271	9		TRANSISTOR NPN SI TO-39 PD=1W FT=150MHZ	28480	1854-0271
A34Q15	1853-0080	6		TRANSISTOR PNP SI PD=300MW FT=30MHZ	28480	1853-0080
A34Q16	1853-0080	6		TRANSISTOR PNP SI PD=300MW FT=30MHZ	28480	1853-0080
A34Q17	1854-0474	4		TRANSISTOR NPN SI PD=310MW FT=100MHZ	04713	2N5551
A34Q18	1854-0597	2		TRANSISTOR NPN 2N5943 SI TO-39 PD=1W	04713	2N5943

See introduction to this section for ordering information.
* Indicates factory selected value.

Table 6-3. Replaceable Parts (continued)

Reference Designator	HP Part Number	C D	Qty.	Description	Mfr Code	Mfr Part Number
A34R1	1810-0269	3	1	NETWORK-RES 9-SIP10.0K OHM X 8	28480	1810-0269
A34R2	2100-0554	5	1	RESISTOR-TRMR 500 10% C TOP-ADJ 1-TRN	28480	2100-0554
A34R3	0757-0273	4	1	RESISTOR 3.01K 1% .125W F TC=0+-100	24546	C4-1/8-T0-3011-F
A34R4	0698-6360	6	3	RESISTOR 10K .1% .125W F TC=0+-25	28480	0698-6360
A34R5	0757-0420	3	1	RESISTOR 750 1% .125W F TC=0+-100	24546	C4-1/8-T0-751-F
A34R6	0757-0401	0	8	RESISTOR 100 1% .125W F TC=0+-100	24546	C4-1/8-T0-101-F
A34R7	0698-6360	6		RESISTOR 10K .1% .125W F TC=0+-25	28480	0698-6360
A34R8	2100-0568	1	1	RESISTOR-TRMR 100 10% C TOP-ADJ 1-TRN	28480	2100-0568
A34R9	0698-6360	6		RESISTOR 10K .1% .125W F TC=0+-25	28480	0698-6360
A34R10	0757-0394	0	1	RESISTOR 51.1 1% .125W F TC=0+-100	24546	C4-1/8-T0-51R1-F
A34R11	0699-1701	1	4	RESISTOR 150.5 .1% .125W F TC=0+-50	28480	0699-1701
A34R12	0699-1670	3	2	RESISTOR 37.35 .1% .125W F TC=0+-50	28480	0699-1670
A34R13	0699-1701	1		RESISTOR 150.5 .1% .125W F TC=0+-50	28480	0699-1701
A34R14	0757-0379	1	2	RESISTOR 12.1 1% .125W F TC=0+-100	19701	MF4C1/8-T0-12R1-F
A34R15	0757-0280	3	6	RESISTOR 1K 1% .125W F TC=0+-100	24546	C4-1/8-T0-1001-F
A34R16	0699-1701	1		RESISTOR 150.5 .1% .125W F TC=0+-50	28480	0699-1701
A34R17	0699-1670	3		RESISTOR 37.35 .1% .125W F TC=0+-50	28480	0699-1670
A34R18	0699-1701	1		RESISTOR 150.5 .1% .125W F TC=0+-50	28480	0699-1701
A34R19	0699-1672	5	2	RESISTOR 96.25 .1% .125W F TC=0+-50	28480	0699-1672
A34R20	0699-1673	6	1	RESISTOR 71.15 .1% .125W F TC=0+-50	28480	0699-1673
A34R21	0699-1672	5		RESISTOR 96.25 .1% .125W F TC=0+-50	28480	0699-1672
A34R22	0699-1703	3	2	RESISTOR 61.11 .1% .125W F TC=0+-50	28480	0699-1703
A34R23	0699-1671	4	1	RESISTOR 247.5 .1% .125W F TC=0+-50	28480	0699-1671
A34R24	0699-1703	3		RESISTOR 61.11 .1% .125W F TC=0+-50	28480	0699-1703
A34R25	0757-0442	9	8	RESISTOR 10K 1% .125W F TC=0+-100	24546	C4-1/8-T0-1002-F
A34R26	0757-1094	9	3	RESISTOR 1.47K 1% .125W F TC=0+-100	24546	C4-1/8-T0-1471-F
A34R27	0757-0442	9		RESISTOR 10K 1% .125W F TC=0+-100	24546	C4-1/8-T0-1002-F
A34R28	0698-8827	4	2	RESISTOR 1M 1% .125W F TC=0+-100	28480	0698-8827
A34R29	2100-3211	7	2	RESISTOR-TRMR 1K 10% C TOP-ADJ 1-TRN	28480	2100-3211
A34R30	0698-3162	0	5	RESISTOR 46.4K 1% .125W F TC=0+-100	24546	C4-1/8-T0-4642-F
A34R31	0698-3447	4	1	RESISTOR 422 1% .125W F TC=0+-100	24546	C4-1/8-T0-422R-F
A34R32	0698-0084	9	7	RESISTOR 2.15K 1% .125W F TC=0+-100	24546	C4-1/8-T0-2151-F
A34R33	0757-0417	8	2	RESISTOR 562 1% .125W F TC=0+-100	24546	C4-1/8-T0-562R-F
A34R34	0757-0397	3	5	RESISTOR 68.1 1% .125W F TC=0+-100	24546	C4-1/8-T0-68R1-F
A34R35	0698-3441	8	1	RESISTOR 215 1% .125W F TC=0+-100	24546	C4-1/8-T0-215R-F
A34R36	0757-0280	3		RESISTOR 1K 1% .125W F TC=0+-100	24546	C4-1/8-T0-1001-F
A34R37	0698-0084	9		RESISTOR 2.15K 1% .125W F TC=0+-100	24546	C4-1/8-T0-2151-F
A34R38	2100-3211	7		RESISTOR-TRMR 1K 10% C TOP-ADJ 1-TRN	28480	2100-3211
A34R39	0757-0346	9	2	RESISTOR 10 1% 0.125W		
A34R40	0757-0442	9		RESISTOR 10K 1% .125W F TC=0+-100	24546	C4-1/8-T0-1002-F
A34R41	0757-0442	9		RESISTOR 10K 1% .125W F TC=0+-100	24546	C4-1/8-T0-1002-F
A34R42	0757-0397	3		RESISTOR 68.1 1% .125W F TC=0+-100	24546	C4-1/8-T0-68R1-F
A34R43	0757-0397	3		RESISTOR 68.1 1% .125W F TC=0+-100	24546	C4-1/8-T0-68R1-F
A34R44	0757-1094	9		RESISTOR 1.47K 1% .125W F TC=0+-100	24546	C4-1/8-T0-1471-F
A34R45	0698-0082	7	3	RESISTOR 464 1% .125W F TC=0+-100	24546	C4-1/8-T0-4640-F
A34R46	0757-0401	0		RESISTOR 100 1% .125W F TC=0+-100	24546	C4-1/8-T0-101-F
A34R47	0698-3162	0		RESISTOR 46.4K 1% .125W F TC=0+-100	24546	C4-1/8-T0-4642-F
A34R48	0757-0438	3	6	RESISTOR 5.11K 1% .125W F TC=0+-100	24546	C4-1/8-T0-5111-F
A34R49	0757-0438	3		RESISTOR 5.11K 1% .125W F TC=0+-100	24546	C4-1/8-T0-5111-F

See introduction to this section for ordering information.
* Indicates factory selected value.

Table 6-3. Replaceable Parts (continued)

Reference Designator	HP Part Number	C D	Qty.	Description	Mfr Code	Mfr Part Number
A34R50	0698-3442	9	2	RESISTOR 237 1% .125W F TC=0+-100	24546	C4-1/8-T0-237R-F
A34R51	0698-3162	0		RESISTOR 46.4K 1% .125W F TC=0+-100	24546	C4-1/8-T0-4642-F
A34R52	0698-0084	9		RESISTOR 2.15K 1% .125W F TC=0+-100	24546	C4-1/8-T0-2151-F
A34R53	0757-0438	3		RESISTOR 5.11K 1% .125W F TC=0+-100	24546	C4-1/8-T0-5111-F
A34R54	0757-0278	9	2	RESISTOR 1.78K 1% .125W F TC=0+-100	24546	C4-1/8-T0-1781-F
A34R55	0698-0084	9		RESISTOR 2.15K 1% .125W F TC=0+-100	24546	C4-1/8-T0-2151-F
A34R56	0757-0199	3	2	RESISTOR 21.5K 1% .125W F TC=0+-100	24546	C4-1/8-T0-2152-F
A34R57	0698-6630	3	1	RESISTOR 20K .1% .125W F TC=0+-25	28480	0698-6630
A34R58	0698-0084	9		RESISTOR 2.15K		
A34R59	0698-6322	0	1	RESISTOR 4K .1% .125W F TC=0+-25	28480	0698-6322
A34R60	0698-8827	4		RESISTOR 1M 1% .125W F TC=0+-100	28480	0698-8827
A34R61	0698-3154	0	1	RESISTOR 4.22K 1% .125W F TC=0+-100	24546	C4-1/8-T0-4221-F
A34R62	0757-0401	0		RESISTOR 100 1% .125W F TC=0+-100	24546	C4-1/8-T0-101-F
A34R63	0757-0280	3		RESISTOR 1K 1% .125W F TC=0+-100	24546	C4-1/8-T0-1001-F
A34R64	0757-0418	9	1	RESISTOR 619 1% .125W F TC=0+-100	24546	
A34R65	0757-0401	0		RESISTOR 100 1% .125W F TC=0+-100	24546	C4-1/8-T0-101-F
A34R66	0757-0417	8	1	RESISTOR 562	24546	
A34R67	0698-3435	0	2	RESISTOR 38.3 1% .125W F TC=0+-100	03888	0698-3435
A34R68	0698-3435	0		RESISTOR 38.3 1% .125W F TC=0+-100	03888	0698-3435
A34R69	0757-0397	3		RESISTOR 68.1 1% .125W F TC=0+-100	24546	C4-1/8-T0-68R1-F
A34R70	0757-0397	3		RESISTOR 68.1 1% .125W F TC=0+-100	24546	C4-1/8-T0-68R1-F
A34R71	0757-1094	9		RESISTOR 1.47K 1% .125W F TC=0+-100	24546	C4-1/8-T0-1471-F
A34R72	0698-0082	7		RESISTOR 464 1% .125W F TC=0+-100	24546	C4-1/8-T0-4640-F
A34R73	0757-0401	0		RESISTOR 100 1% .125W F TC=0+-100	24546	C4-1/8-T0-101-F
A34R74	0698-3162	0		RESISTOR 46.4K 1% .125W F TC=0+-100	24546	C4-1/8-T0-4642-F
A34R75	0757-0438	3		RESISTOR 5.11K 1% .125W F TC=0+-100	24546	C4-1/8-T0-5111-F
A34R76	0757-0438	3		RESISTOR 5.11K 1% .125W F TC=0+-100	24546	C4-1/8-T0-5111-F
A34R77	0757-0401	0		RESISTOR 100 1% .125W F TC=0+-100	24546	C4-1/8-T0-101-F
A34R78	0757-0399	5	1	RESISTOR 82.5 1% .125W F TC=0+-100	24546	C4-1/8-T0-82R5-F
A34R79	0698-3442	9		RESISTOR 237 1% .125W F TC=0+-100	24546	C4-1/8-T0-237R-F
A34R80	0698-3162	0		RESISTOR 46.4K 1% .125W F TC=0+-100	24546	C4-1/8-T0-4642-F
A34R81	0757-0278	9		RESISTOR 1.78K 1% .125W F TC=0+-100	24546	C4-1/8-T0-1781-F
A34R82	0698-0084	9		RESISTOR 2.15K 1% .125W F TC=0+-100	24546	C4-1/8-T0-2151-F
A34R83	0757-0438	3		RESISTOR 5.11K 1% .125W F TC=0+-100	24546	C4-1/8-T0-5111-F
A34R84	0757-0199	3		RESISTOR 21.5K 1% .125W F TC=0+-100	24546	C4-1/8-T0-2152-F
A34R85	0698-0084	9		RESISTOR 2.15K 1% .125W F TC=0+-100	24546	C4-1/8-T0-2151-F
A34R86	0757-0401	0		RESISTOR 100 1% .125W F TC=0+-100	24546	C4-1/8-T0-101-F
A34R87	0757-0280	3		RESISTOR 1K 1% .125W F TC=0+-100	24546	C4-1/8-T0-1001-F
A34R88	0757-0280	3		RESISTOR 1K 1% .125W F TC=0+-100	24546	C4-1/8-T0-1001-F
A34R89	0698-3156	2	2	RESISTOR 14.7K 1% .125W F TC=0+-100	24546	C4-1/8-T0-1472-F
A34R90	0698-3156	2		RESISTOR 14.7K 1% .125W F TC=0+-100	24546	C4-1/8-T0-1472-F
A34R91	0698-3628	3	2	RESISTOR 220 5% 2W MO TC=0+-200	28480	0698-3628
A34R92	0760-0024	0	1	RESISTOR 100 5% 1W MO TC=0+-200	28480	0760-0024
A34R93	0698-3628	3		RESISTOR 220 5% 2W MO TC=0+-200	28480	0698-3628
A34R94	0757-0442	9		RESISTOR 10K 1% .125W F TC=0+-100	24546	C4-1/8-T0-1002-F
A34R95	0698-3160	8	1	RESISTOR 31.6K 1% .125W F TC=0+-100	24546	C4-1/8-T0-3162-F
A34R96	0757-0398	4	2	RESISTOR 75 1% .125W	24546	
A34R97	0757-0398	5	1	RESISTOR 12.1		
A34R98	0757-0280	3		RESISTOR 1K 1% .125W F TC=0+-100	24546	C4-1/8-T0-1001-F

See introduction to this section for ordering information.
* Indicates factory selected value.

Table 6-3. Replaceable Parts (continued)

Reference Designator	HP Part Number	C D	Qty.	Description	Mfr Code	Mfr Part Number
A34R99	0698-3429	2	1	RESISTOR 19.6	24546	
A34R100	0698-3428	1	1	RESISTOR 14.7	24546	
A34R101	0757-0442	9		RESISTOR 10K 1% .125W F TC=0+-100	24546	C4-1/8-T0-1002-F
A34R102	0757-0442	9		RESISTOR 10K 1% .125W F TC=0+-100	24546	C4-1/8-T0-1002-F
A34R103	0757-0442	9		RESISTOR 10K 1% .125W F TC=0+-100	24546	C4-1/8-T0-1002-F
A34R104	2100-3252	6	1	RESISTOR-TRMR 5K 10% C TOP-ADJ 1-TRN	28480	2100-3252
A34R105	0698-4367	9	1	RESISTOR 20.5 1% .125W F TC=0+-100	03888	PME55-1/8-T0-20R5-F
A34R106	0757-0379	1		RESISTOR 75 1% .125W	24546	
A34R107	0757-0401	0		RESISTOR 100 1% .125W F TC=0+-100	24546	C4-1/8-T0-101-F
A34R108	0757-0401	0		RESISTOR 100 1% .125W F TC=0+-100	24546	C4-1/8-T0-101-F
A34R109	2100-3210	6	1	RESISTOR-TRMR 10K 10% C TOP-ADJ 1-TRN	28480	2100-3210
A34R110	0757-0180	2	1	RESISTOR 31.6 1% .125W F TC=0+-100	28480	0757-0180
A34R111	0757-0402	1	1	RESISTOR 110		
A34R112	0698-0084	9		RESISTOR 2.15K		
A34R113	0698-0082	7		RESISTOR 464 1% .125W F TC=0+-100	24546	C4-1/8-T0-4640-F
A34U1	1826-0147	9	1	IC 7812 V RGLTR TO-220	04713	MC7812CP
A34U2	1826-0221	0	1	IC V RGLTR TO-220	04713	MC7912CT
A34U3	1826-0122	0	1	IC 7805 V RGLTR TO-220	07263	7805UC
A34U4	1820-1470	1	1	IC MUXR/DATA-SEL TTL LS 2-TO-1-LINE QUAD	01295	SN74LS157N
A34U5	1858-0047	5	2	TRANSISTOR ARRAY 16-PIN PLSTC DIP	13606	ULN-2003A
A34U6	1820-1433	6	3	IC SHF-RGTR TTL LS R-S SERIAL-IN PRL-OUT	01295	SN74LS164N
A34U7	1820-1416	5	1	IC SCHMITT-TRIG TTL LS INV HEX 1-INP	01295	SN74LS14N
A34U8	1826-0275	4	2	IC 78L12A V RGLTR TO-92	04713	MC78L12ACP
A34U9	1826-1328	0	1	IC OP AMP LOW-NOISE DUAL 8-DIP-P PKG	28480	1826-1328
A34U10	1826-0476	7	1	IC SWITCH ANLG 8-DIP-P PKG	01295	TL601CP
A34U11	1820-1197	9	1	IC GATE TTL LS NAND QUAD 2-INP	01295	SN74LS00N
A34U12	1820-1730	6	2	IC FF TTL LS D-TYPE POS-EDGE-TRIG COM	01295	SN74LS273N
A34U13	1820-1433	6		IC SHF-RGTR TTL LS R-S SERIAL-IN PRL-OUT	01295	SN74LS164N
A34U14	1820-1433	6		IC SHF-RGTR TTL LS R-S SERIAL-IN PRL-OUT	01295	SN74LS164N
A34U15	1820-1730	6		IC FF TTL LS D-TYPE POS-EDGE-TRIG COM	01295	SN74LS273N
A34U16	1826-1386	4	1	IC AD7541AKN	28480	AD7541AKN
A34U17	1826-0635	0	1	IC OP AMP LOW-OFS 8-DIP-P PKG	06665	OP-07CP
A34U18	1858-0047	5		TRANSISTOR ARRAY 16-PIN PLSTC DIP	13606	ULN-2003A
A34U19	1826-1374	6	1	IC LT1037CH	28480	1826-1374
A34U20	1826-1328	0	1	IC OP AMP LOW-NOISE DUAL 8-DIP-P PKG	28480	1826-1328
A34U21	1826-0275	4		IC 78L12A V RGLR TO-92	04713	MC78L12 ACP

See introduction to this section for ordering information.
* Indicates factory selected value.

Table 6-3. Replaceable Parts (continued)

Reference Designator	HP Part Number	C D	Qty.	Description	Mfr Code	Mfr Part Number
A34A1	04194-66553	3	1	ATTENUATOR/POWER SPLITTER BOARD ASSEMBLY FOR OPTION 375 UNITS	28480	04194-66553
A34A1C1	0180-3363	6	6	CAPACITOR-FXD 22UF +-20% 25VDC AL	28480	0180-3363
A34A1C2	0180-3363	6		CAPACITOR-FXD 22UF +-20% 25VDC AL	28480	0180-3363
A34A1C3				NOT ASSIGNED		
A34A1C4	0180-3363	6		CAPACITOR-FXD 22UF +-20% 25VDC AL	28480	0180-3363
A34A1C5	0180-3363	6		CAPACITOR-FXD 22UF +-20% 25VDC AL	28480	0180-3363
A34A1C6	0180-3363	6		CAPACITOR-FXD 22UF +-20% 25VDC AL	28480	0180-3363
A34A1C7	0180-3363	6		CAPACITOR-FXD 22UF +-20% 25VDC AL	28480	0180-3363
A34A1C8	0160-2238	0	2	CAPACITOR-FXD 1.5PF	28480	0160-2238
A34A1C9	0160-2238	0		CAPACITOR-FXD 1.5PF	28480	0160-2238
A34A1C10	0160-4832	4	5	CAPACITOR-FXD .01UF +-10% 100VDC CER	28480	0160-4832
A34A1C11	0160-4832	4		CAPACITOR-FXD .01UF +-10% 100VDC CER	28480	0160-4832
A34A1C12	0160-4832	4		CAPACITOR-FXD .01UF +-10% 100VDC CER	28480	0160-4832
A34A1C13	0160-4832	4		CAPACITOR-FXD .01UF +-10% 100VDC CER	28480	0160-4832
A34A1C14	0160-4832	4		CAPACITOR-FXD .01UF +-10% 100VDC CER	28480	0160-4832
A34A1CR1	1902-0945	7	2	DIODE-ZNR 3V 5% DO-35 PD=.4W TC=-.043%	28480	1902-0945
A34A1CR2	1901-0179	7	2	DIODE-SWITCHING	28480	1901-0179
A34A1CR3	1901-0179	7		DIODE-SWITCHING	28480	1901-0179
A34A1CR4	1902-0945	7		DIODE-ZNR 3V 5% DO-35 PD=.4W TC=-.043%	28480	1902-0945
A34A1J1	1251-4683	7	6	CONNECTOR-SGL CONT SKT .04-IN-BSC-SZ RND	28480	1251-4683
A34A1J2	1251-4683	7		CONNECTOR-SGL CONT SKT .04-IN-BSC-SZ RND	28480	1251-4683
A34A1J3	1251-4683	7		CONNECTOR-SGL CONT SKT .04-IN-BSC-SZ RND	28480	1251-4683
A34A1J4	1251-4683	7		CONNECTOR-SGL CONT SKT .04-IN-BSC-SZ RND	28480	1251-4683
A34A1J5	1251-4683	7		CONNECTOR-SGL CONT SKT .04-IN-BSC-SZ RND	28480	1251-4683
A34A1J6	1251-4683	7		CONNECTOR-SGL CONT SKT .04-IN-BSC-SZ RND	28480	1251-4683
A34A1J7	1250-1810	4	3	CONNECTOR-RF SMB M PC-OHM	28480	1250-1810
A34A1J8	1250-1810	4		CONNECTOR-RF SMB M PC-OHM	28480	1250-1810
A34A1J9	1250-1810	4		CONNECTOR-RF SMB M PC-OHM	28480	1250-1810
A34A1K1	0490-1485	6	3	RELAY SW	28480	0490-1485
A34A1K2	0490-1485	6		RELAY SW	28480	0490-1485
A34A1K3	0490-1485	6		RELAY SW	28480	0490-1485
A34A1L1	9100-2259	8	6	INDUCTOR RF-CH-MLD 1.5UH 10% .105DX.26LG	28480	9100-2259
A34A1L2	9100-2259	8		INDUCTOR RF-CH-MLD 1.5UH 10% .105DX.26LG	28480	9100-2259
A34A1L3	9100-2259	8		INDUCTOR RF-CH-MLD 1.5UH 10% .105DX.26LG	28480	9100-2259
A34A1L4	9100-2259	8		INDUCTOR RF-CH-MLD 1.5UH 10% .105DX.26LG	28480	9100-2259
A34A1L5	9100-2259	8		INDUCTOR RF-CH-MLD 1.5UH 10% .105DX.26LG	28480	9100-2259
A34A1L6	9100-2259	8		INDUCTOR RF-CH-MLD 1.5UH 10% .105DX.26LG	28480	9100-2259
A34A1R1	0699-1788	4	2	RESISTOR 91.67 .1%	28480	0699-1788
A34A1R2	0699-1789	5	1	RESISTOR 371.3 .1%	28480	0699-1789
A34A1R3	0699-1788	4		RESISTOR 91.67 .1%	28480	0699-1789
A34A1R4	0699-1790	8	2	RESISTOR 144.4 .1%	28480	0699-1790
A34A1R5	0699-1791	9	1	RESISTOR 106.7 .1%	28480	0699-1791
A34A1R6	0699-1790	8		RESISTOR 144.4 .1%	28480	0699-1790
A34A1R7	0757-0398	4	4	RESISTOR 75 1%	24546	
A34A1R8	0757-0442	9	1	RESISTOR 10K 1% .125W F TC=0+-100	24546	C4-1/8-T0-1002-F
A34A1R9	0698-0083	8	1	RESISTOR 1.96K 1% .125W F TC=0+-100	24546	C4-1/8-T0-1961-F
A34A1R10	0757-0398	4		RESISTOR 75 1%	24546	

See introduction to this section for ordering information.
* Indicates factory selected value.

Table 6-3. Replaceable Parts (continued)

Reference Designator	HP Part Number	C D	Qty.	Description	Mfr Code	Mfr Part Number
A34A1R11	0699-1792	0	2	RESISTOR 75 .1%		0699-1792
A34A1R12	0757-0398	4		RESISTOR 75 1%		
A34A1R13	0757-0398	4		RESISTOR 75 1%		
A34A1R14	0699-1792	0		RESISTOR 75 .1%	28480	0699-1792
A34A1TP1	0360-1653	5	1	CONNECTOR-SGL CONT PIN .045-IN-BSC-SZ SQ	28480	0360-1653

See introduction to this section for ordering information.
 * Indicates factory selected value.

Control Unit

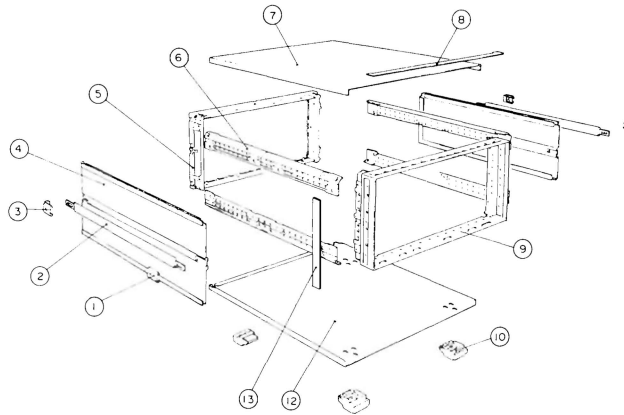

Measurement Unit

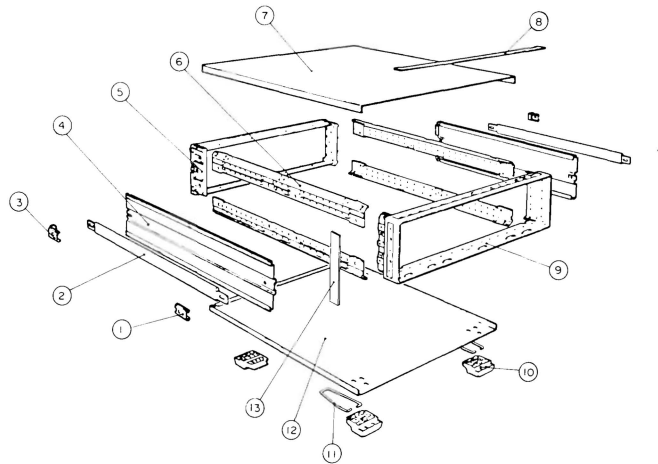

Ref. Des.	Control Unit		Measurement Unit		Description
	Part Number	Qty	Part Number	Qty	
1	5041-6819	2	5041-6819	2	FRONT CAP
2	5060-9805	2	5060-9805	2	STRAP HANDLE
3	5041-6820	2	5041-6820	2	REAR CAP
4	5060-9948	2	5060-9938	2	SIDE COVER
5	5021-5808	1	5021-5804	1	REAR FRAME
6	5021-5838	4	5021-5838	4	CORNER STRUT
7	5061-9436	1	5061-9436	1	TOP COVER
8	5040-7202	1	5040-7202	1	TOP TRIM
9	5021-5807	1	5021-5803	1	FRONT FRAME
10	5040-7201	4	5040-7201	4	FOOT
11	N/A	0	1460-1345	2	TILT STAND
12	5061-9448	1	5061-9448	1	BOTTOM COVER
13	5001-0441	2	5001-0439	2	SIDE TRIM

Figure 6-1. Major Mechanical Parts--Exploded View

Table 6-4. Board Mounted Hardware (Sheet 1 of 3)

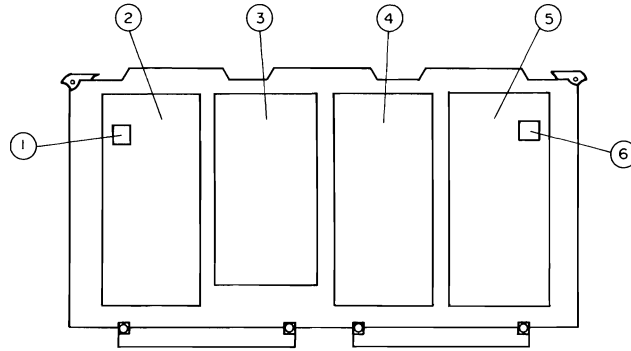

Board No.	Ref. Des.	Part Number	Qty	Description
A1		04194-01204	1	Angle, circuit side
A2		04194-00635	1	Shield Plate
		04194-00636	1	Shield Plate, circuit side
		1205-0513	1	Heat Sink for U2
		1205-0310	2	Heat Sink for Q11 and Q12
A3		04194-01204	2	Angle, circuit side
		04194-01206	3	Heat Sink for CR12, CR13, CR14
		04194-01207	1	Heat Sink for CR15
		04194-01208	1	Heat Sink for CR15
A4		1205-0310	1	Heat Sink for Q5
		1205-0513	1	Heat Sink for U3
A9		04194-00624	1	Shield, Large
		04194-00628	1	Shield, Large, circuit side
		04194-00629	1	Shield, Small
		04194-00630	1	Shield, Small, circuit side
		04194-01211	1	Heat Sink for Q10, Q11 and Q12
A10	1	04192-00651	1	Shield
	2	04194-00615	1	Shield
		04194-00616	1	Shield, circuit side
	3	04194-00617	1	Shield
		04194-00618	1	Shield, circuit side
	4	04194-00619	1	Shield
		04194-00620	1	Shield, circuit side
	5	04194-00621	1	Shield
		04194-00622	1	Shield, circuit side
	6	04192-00651	1	Shield

Table 6-4. Board Mounted Hardware (Sheet 2 of 3)

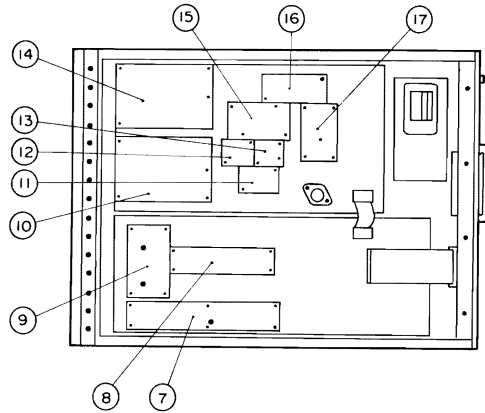

Board No.	Ref. Des.	Part Number	Qty	Description
A11		04194-00623	1	Shield, Large
		04194-00624	1	Shield, Large, on circuit side
		04194-00637	1	Shield
		04194-00638	1	Shield on circuit side
		04194-00637	1	Shield, Small
		04194-00638	1	Shield, Small, on circuit side
		04194-00632	1	Shield Plate on circuit side
A20	7	04194-00723	1	Shield
		04194-00724	1	Shield on circuit side
	8	04194-00725	1	Shield
		04194-00726	1	Shield on circuit side
	9	04194-00721	1	Shield
		04194-00722	1	Shield on circuit side
		1205-0095	9	Heat Sink for Q7, Q8, Q9, Q10, Q13, Q17, Q18, Q19 and Q20
	04194-29051	1	Heat Sink for U1 and U5	
A21 (A31)	10	04194-00668	1	Shield
		04194-00692	1	Shield on circuit side
	11	04194-00679	1	Shield
		04194-00690	1	Shield on circuit side
	12	04194-00675	1	Shield
		04194-00678	1	Shield on circuit side
	13	04194-00675	1	Shield
		04194-00678	1	Shield on circuit side
	14	04194-00667	1	Shield
		04194-00691	1	Shield on circuit side
	15	04194-00669	1	Shield
		04194-00670	1	Shield on circuit side
	16	04194-00673	1	Shield
		04194-00674	1	Shield on circuit side
	17	04194-00671	1	Shield
		04194-00672	1	Shield on circuit side
		04194-01235	2	Angle on circuit side

Table 6-4. Board Mounted Hardware (Sheet 3 of 3)

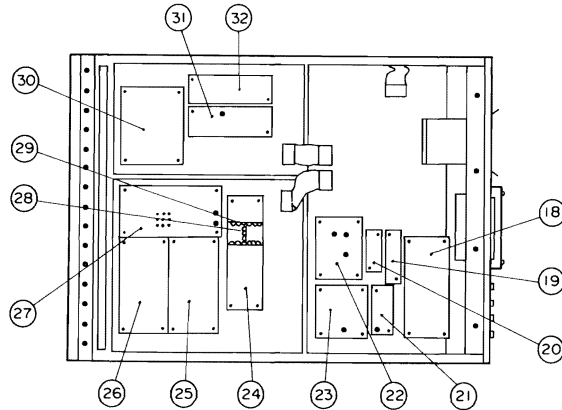

Board No.	Ref. Des.	Part Number	Qty	Description
A22	18	04194-00704	1	Shield
		04194-00709	1	Shield on circuit side
	19	04194-00733	1	Shield
		04194-00708	1	Shield on circuit side
	20	04194-00703	1	Shield
		04194-00732	1	Shield on circuit side
	21	04194-00702	1	Shield
		04194-00707	1	Shield on circuit side
	22	04194-00700	1	Shield
		04194-00705	1	Shield on circuit side
	23	04194-00701	1	Shield
		04194-00706	1	Shield on circuit side
			1205-0513	1
A23	30	04194-00660	1	Shield
		04194-00663	1	Shield on circuit side
	31	04194-00661	1	Shield
		04194-00664	1	Shield on circuit side
	32	04194-00662	1	Shield
		04194-00665	1	Shield on circuit side
A24 (A34)	24	04194-00653	1	Shield
		04194-00659	1	Shield on circuit side
	25	04194-00651	1	Shield
		04194-00655	1	Shield on circuit side
	26	04194-00652	1	Shield
		04194-00654	1	Shield on circuit side
	27	04194-00650	1	Shield
		04194-00659	1	Shield on circuit side
	28	04194-00657	1	Shield Plate
		04194-00658	2	Shield Plate
	29	04194-01252	1	Angle on circuit side
		1205-0095	6	Heat Sink
1205-0475		1	Heat Sink for Q18	

Table 6-5. Coaxial Cable Assemblies

Marker	Part Number	Description
	04194-61612	A10J1 to A10C61
	04194-61696	A20J5 to A20Q4
1	04194-61693	A22J11 to A22E2
2	04194-61691	A21R127 to A21A1J2
3	04194-61692	A21R141 to A21A2J2
4	04194-61686	A22J8 to A23J3
A	04194-61618	A11J2 to A11R149
B	04194-61620	A11J3 to A11XR2bc
C	04194-61619	A11J4 to A11R173
O	04194-61681	A22J2 to A24J2
P	04194-61694	A22J12 to A22E1
V	04194-61682	A21J6 to A22J9
X	04194-61685	A22J5 to A23J2
Y	04194-61684	A20J3 to A21J5
Z	04194-61683	A20J7 to A22J1

Table 6-6. Flat Cable Assembly

Part Number	Description
04194-65001	A5J2 to A4J4, 26-pin
04194-61622	A11J1 to A11J5, 16-pin
04194-65002	A12J2 to A13J1, 40-pin
04194-65004	A15 to A12J1, 34-pin
04194-65003	A15 to A4J3, 26-pin
04194-61651	A20J2 to A21J2, 24-pin
04194-61656	A20J4 to A22J15, 40-pin
04194-61652	A22J3 to A24J1, 24-pin
04194-61651	A22J4 to A23J4, 24-pin
04194-61655	A22J10 to A26J1, 24-pin

Table 6-7. Other Cables

Part Number	Description
04194-61629	A4 to A17J2
04194-61627	A17 to A5J1
04194-61653	A20 to A25J2 (Option 001 only)

Table 6-8. Front-Panel Components

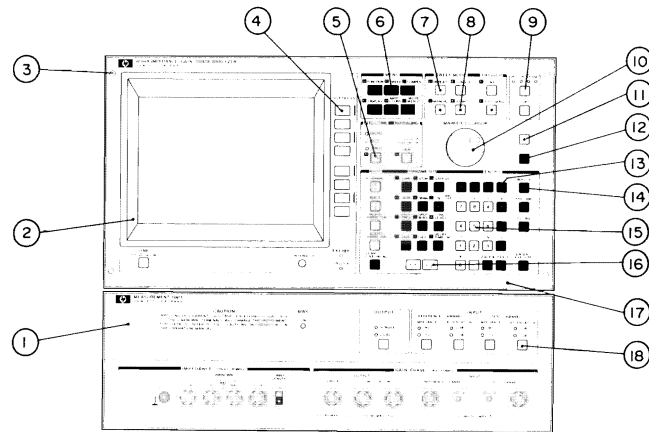

Ref. Des.	Part Number	Qty	Description
1	04194-00253	1	Front Panel, HP (Option 350 Units)
	04194-00254		Front Panel, YHP (Option 350 Units)
	04194-00255		Front Panel, HP (Option 375 Units)
	04194-00256		Front Panel, YHP (Option 375 Units)
2	04194-00207	1	Sub Panel
	3150-0501	1	Filter
	04194-40003	1	Bezel
3	04194-24008	4	Washer
	0515-0907	4	Screw E3
4	5041-0277	1	Key Cap, Half Pearl
5	5041-0922	3	Key Cap, Quarter Pearl Arrow
6	5041-0343	6	Key Cap, Half Gray
7	5041-0285	5	Key Cap, Quarter Pearl Lamp
8	5041-0351	1	Key Cap, Quarter Gray Lamp
9	5041-0726	1	Key Cap, Quarter LCL
10	10370-3033	1	Knob
11	5041-0450	1	Key Cap, Quarter Blue Lamp
12	5041-0507	1	Key Cap, Quarter Green
13	5041-0342	20	Key Cap, Quarter Light-Gray
14	5041-0375	6	Key Cap, Quarter Smoke Gray
15	5041-1755	1	Key Cap, Quarter (.)
	5041-1756	1	Key Cap, Quarter (0)
	5041-1757	1	Key Cap, Quarter (1)
	5041-1758	1	Key Cap, Quarter (2)
	5041-1759	1	Key Cap, Quarter (3)
	5041-1760	1	Key Cap, Quarter (4)
	5041-1761	1	Key Cap, Quarter (5)
	5041-1762	1	Key Cap, Quarter (6)
	5041-1763	1	Key Cap, Quarter (7)
	5041-1764	1	Key Cap, Quarter (8)
5041-1762	1	Key Cap, Quarter (9)	
16	5041-0855	2	Key Cap, Half Pearl Arrow
17	04194-00201	1	Panel, Front (HP)
	04194-00202	1	Panel, Front (YHP)
18	5041-0276	9	Key Cap, Quarter Pearl Gray

Table 6-9. Control Unit Front Panel Components

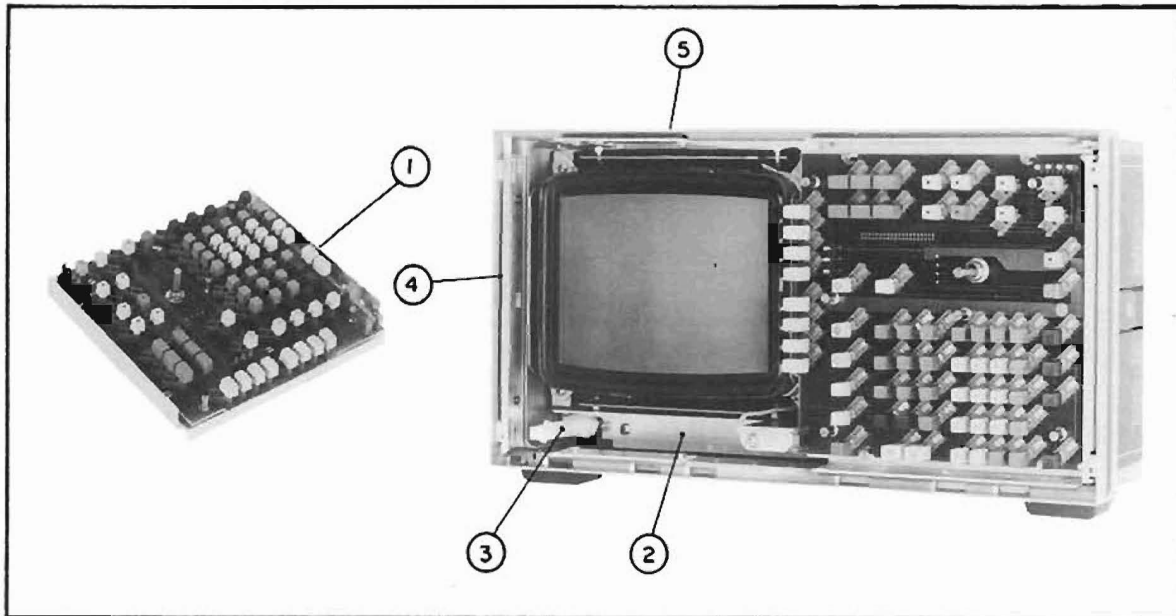

Ref. Des.	Part Number	Qty	Description
1	04194-00204	2	Angle, Keyboard
2	04145-00629	2	Plate
3	04194-40001	1	Rod
	5041-0564	1	Key Cap
	3101-2216	1	Power Switch
	04194-61635	1	Cable Assembly
4	04194-00205	2	Angle, Front Panel
5	04194-00612	1	Shield Plate, Top

Table 6-10. Control Unit Rear Panel Components (1 of 2)

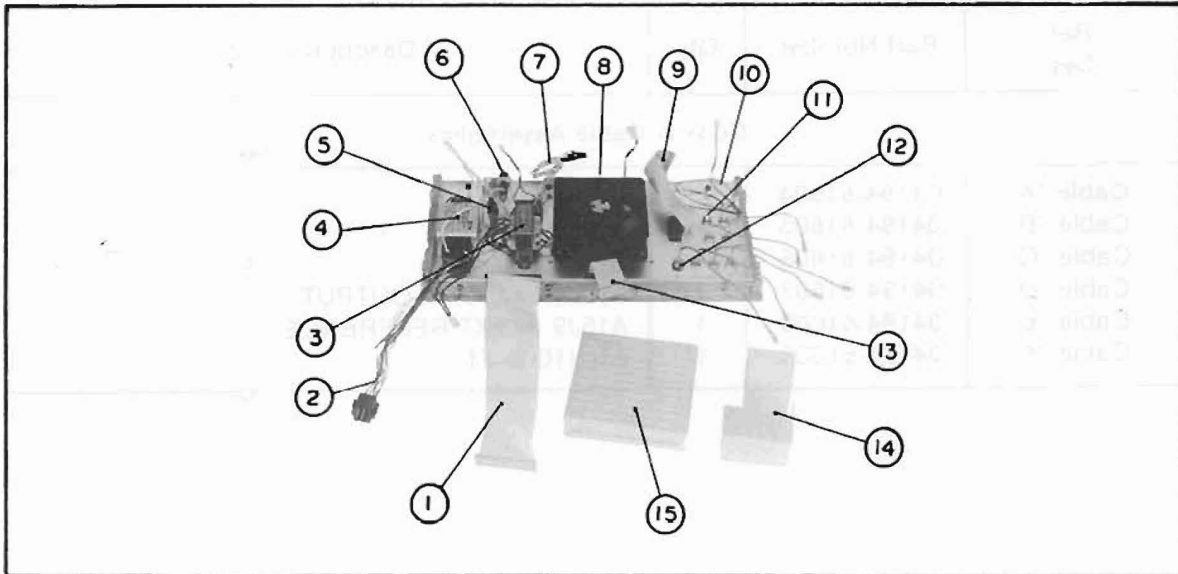

Ref. Des.	Part Number	Qty	Description
1	04194-61611	1	Flat 50-pin, A15J2 to J5
2	04194-61615	1	Wire Assembly, AMP 9-pin, A14J3 to J6
3	9100-4518	1	Transformer Assembly
4	9135-0280	1	Line Filter
5	2110-0055	1	Fuse, 4A Normal Blow (100/120V operation)
	2110-0015	1	Fuse, 2.5A Slow Blow (220/240V operation)
	2110-0569	1	Nut, Fuse Holder
	2110-0564	1	Fuse Holder
	2110-0565	1	Cap, Fuse Holder
6	2110-0569	1	Nut, Fuse Holder
	2110-0564	1	Fuse Holder
	2110-0056	1	Fuse Inside, 6A
	2110-0565	1	Cap, Fuse Holder
	04194-01205	1	Angle, Fuse Holder
7	04194-61616	1	Wire Assembly, AMP 4-pin
8	3160-0465	1	Blower
	04194-61636	1	Cable Assembly, Blower
9	04194-61610	1	Cable Assembly, HP-IB
10	04194-61623	1	Cable Assembly, EXT TRIG/PROG START
	2950-0001	2	Nut
	2190-0016	2	Washer
	1250-0083	2	BNC Connector, EXT TRIG/PROG START
11	2950-0035	6	Nut
	2190-0102	5	Washer
	1250-0252	6	BNC Connector, Body
12	5040-3324	1	Insulator, Outer
	5040-3325	1	Insulator, Inner
13	04194-61612	1	Flat 25-pin, 8-BIT I/O
14	04194-04005	1	Cover
15	04194-04005	1	Cover, Blower

Table 6-10. Control Unit Rear Panel Components (2 of 2)

Ref. Des.	Part Number	Qty	Description
Coaxial Cable Assemblies			
Cable "A"	04194-61604	1	A15J5 to J4
Cable "B"	04194-61605	1	A15J6 to J3
Cable "C"	04194-61606	1	A15J7 to J2
Cable "D"	04194-61607	1	A15J8 to 10MHz OUTPUT
Cable "E"	04194-61609	1	A15J9 to EXT REFERENCE
Cable "F"	04194-61608	1	A15J10 to J1

Table 6-11. CRT Components

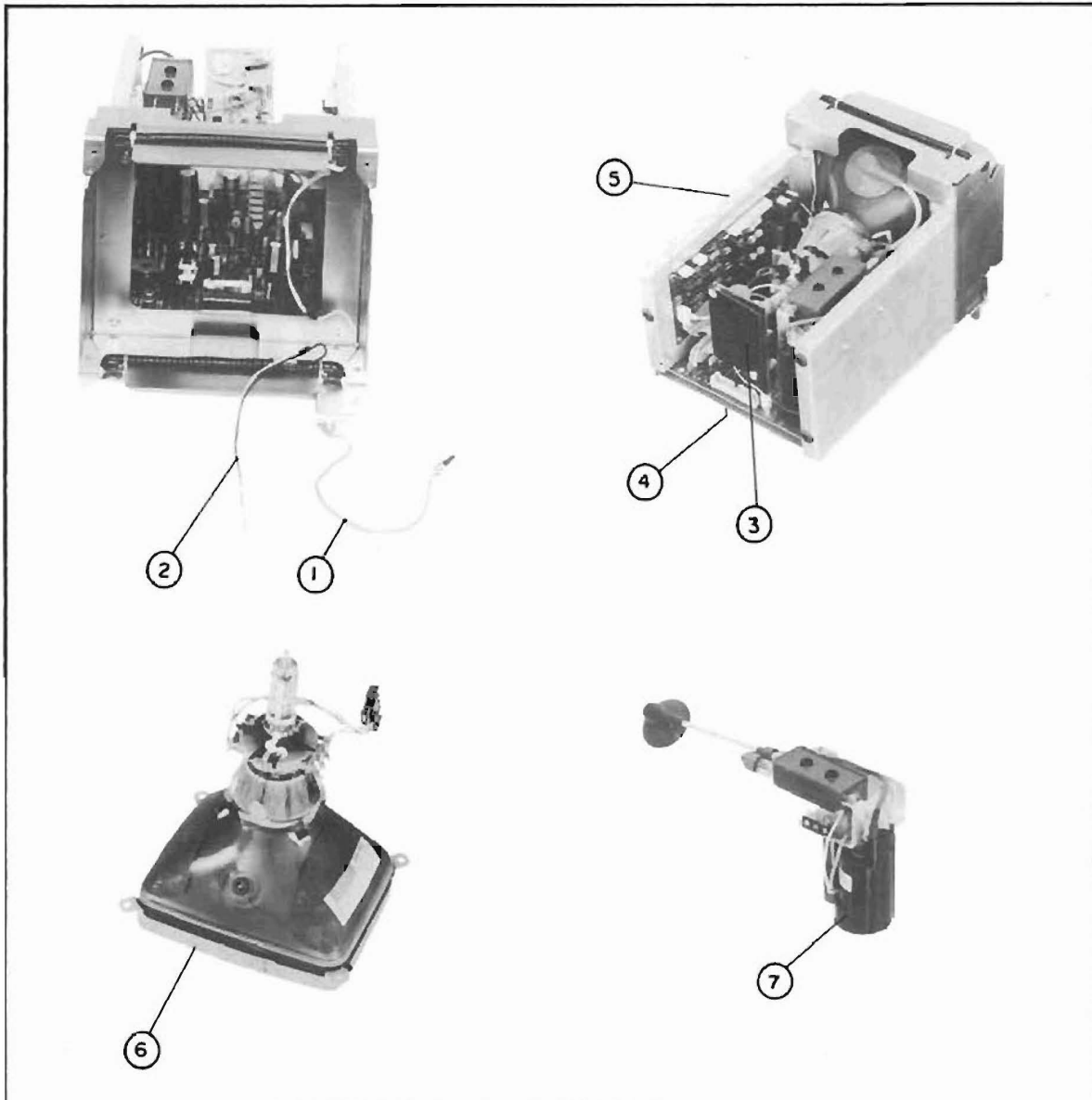

Ref. Des.	Part Number	Qty	Description
1	2100-4118	1	R Variable, INTENSITY
	04194-61628	1	Cable Assembly, INTENSITY
2	04194-61632	1	Coil Assembly, Degausser
3	04194-04004	1	Cover for A17 Board Assembly
4	04194-04002	1	Cover for A4 Board Assembly
5	04194-04003	1	Cover for A5 Board Assembly
6	04194-69106	1	CRT Assembly
7	04194-69107	1	H.V. Block Assembly (HVR and FBT)

Table 6-12. Measurement Unit Front Panel Components

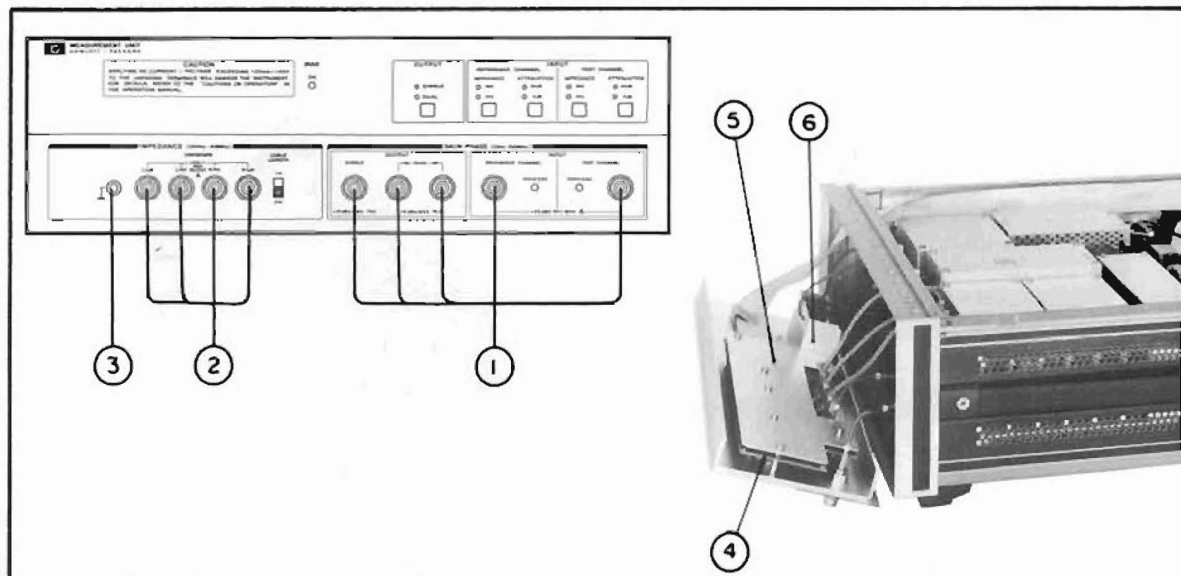

Ref. Des.	Part Number	Qty	Description
1	1250-0252	5	BNC Connector, Body
	2950-0035	5	Nut, BNC
	2190-0102	5	Washer, BNC
2	1250-0252	4	BNC Connector, Body
	2950-0035	4	Nut, BNC
	5040-3324	4	Insulator, Outside
	5040-3325	4	Insulator, Inside
3	1510-0130	1	Ground Post
	2950-0006	1	Nut
	2190-0084	1	Washer
4	04194-66526	1	A26 Board Assembly
5	04194-00730	1	Shield Plate
6	04194-01251	1	Bracket

Coaxial Cable Assemblies

Cable "F"	04194-61666	1	A24A1J7 to SINGLE OUTPUT (Option 350)
	04194-61676		A24A1J7 to SINGLE OUTPUT (Option 375)
Cable "G"	04194-61667	1	A24A1J8 to DUAL OUTPUT (Option 350)
	04194-61677		A24A1J8 to DUAL OUTPUT (Option 375)
Cable "H"	04194-61668	1	A24A1J9 to DUAL OUTPUT (Option 350)
	04194-61678		A24A1J9 to DUAL OUTPUT (Option 375)
Cable "I"	04194-61669	1	A21A2J1 to REFERENCE CHANNEL (Option 350)
	04194-61679		A21A2J1 to REFERENCE CHANNEL (Option 375)
Cable "J"	04194-61670	1	A21A1J1 to TEST CHANNEL (Option 350)
	04194-61680		A21A1J1 to TEST CHANNEL (Option 375)
Cable "K"	04194-61671	1	A20J6 to L _{CUR} Terminal
Cable "L"	04194-61672	1	A20J1 to H _{POT} Terminal
Cable "M"	04194-61673	1	A23J1 to L _{POT} Terminal
Cable "N"	04194-61674	1	A24J9 to H _{CUR} Terminal

Table 6-13. Measurement Unit Rear Panel Components

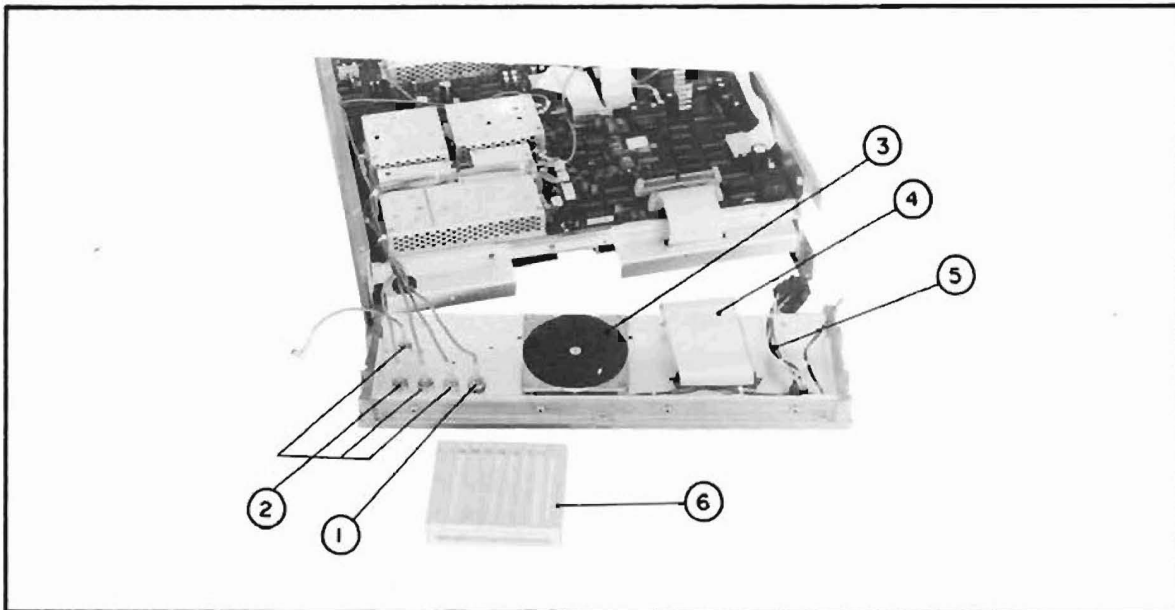

Ref. Des.	Part Number	Qty	Description
1	1250-0252	5	BNC Connector, Body
	5040-3324	1	Insulator, Outer
	5040-3325	1	Insulator, Inner
	2950-0035	1	Nut
2	1250-0252	4	BNC Connector, Body
	2190-0102	4	Washer
	2950-0035	4	Nut
3	3160-0474	1	Blower, DC
4	04194-61657	1	Flat 50-pin, A22J14 to J5
5	04194-61658	1	Wire Assembly, AMP 9-pin, A22J17 to J6
6	04194-04051	1	Cover, Blower
Coaxial Cable Assemblies			
Cable "A"	04194-61661	1	A22J7 to J2
Cable "B"	04194-61662	1	A22J6 to J1
Cable "C"	04194-61663	1	A22J13 to J3
Cable "D"	04194-61664	1	A21J1 to J4
Cable "E"	04194-61665	1	A25J1 to REFERENCE OVEN, (Opt 001 only)

**THIS
PAGE
LEFT
BLANK**

**SCANS
By
Artek Media**

SECTION 7

MANUAL CHANGES

7-1. INTRODUCTION

This section contains information for adapting this manual to instruments for which the content does not directly apply. The following paragraphs explain how to adapt this manual to apply to an older instrument with a serial prefix/number or ROM version lower than that given on the title page.

7-2. MANUAL CHANGES

To adapt this manual to your instrument, refer to Table 7-1 and make all of the manual changes listed opposite your instrument serial number. Perform these changes in the sequence listed.

If your instrument serial number is not listed on the title page of this manual or in Table 7-1, it may be documented in a yellow MANUAL CHANGES supplement. For additional information about serial number coverage, refer to INSTRUMENTS COVERED BY MANUAL in Section 1 of the 4194A's Operation Manual.

Table 7-1. Manual Changes by Serial Number

Serial Prefix or Number	Make Manual Changes
2521J00195 and below	1, 2, 3, 4
2521J00196 through 2521J00275	2, 3, 4, 5
2610J00276 through 2610J00279	3, 4, 5
2611J00280 through 2611J00294	4, 5
2614J-	5

If your 4194A is serial-numbered 2614J- or below but has version 2.2 firmware installed, disregard changes 1 and 5.

CHANGE 1

See Table 7-2, Parts Information.

Change the component locations of the A7 board as shown in Figure 7-1.

Change the schematic diagram of the A7 board as described below.

Set W2 to position 1 (64K bit).

Delete the asterisks by U2, U4, U5, U20 through U27, and U69 through U73.

Delete the note concerning the asterisks by these ICs.

Delete the information related to Self Test #38.

CHANGE 2

Change the schematic diagram of A26 as shown in Figure 7-2.

CHANGE 3

See Table 7-2, Parts Information.

Change the component locations and schematic diagrams of A21A1 and A21A2 for option 350 or A31A1 and A31A2 for option 375 as shown in Figures 7-3 through 7-10.

CHANGE 4

Delete A3CR22 from the parts list, component locations, and schematic diagram.

CHANGE 5

See Table 7-2, Parts Information.

Change the component locations of A7 board as shown in Figure 7-1.

Change the schematic diagram of the A7 board as described below.

Set W2 to position 1 (64K bit).

Delete the asterisks by U2, U4, U5, U20 through U27, and U69 through U73.

Delete the note concerning the asterisks by these ICs.

Delete the information related to Self Test #38.

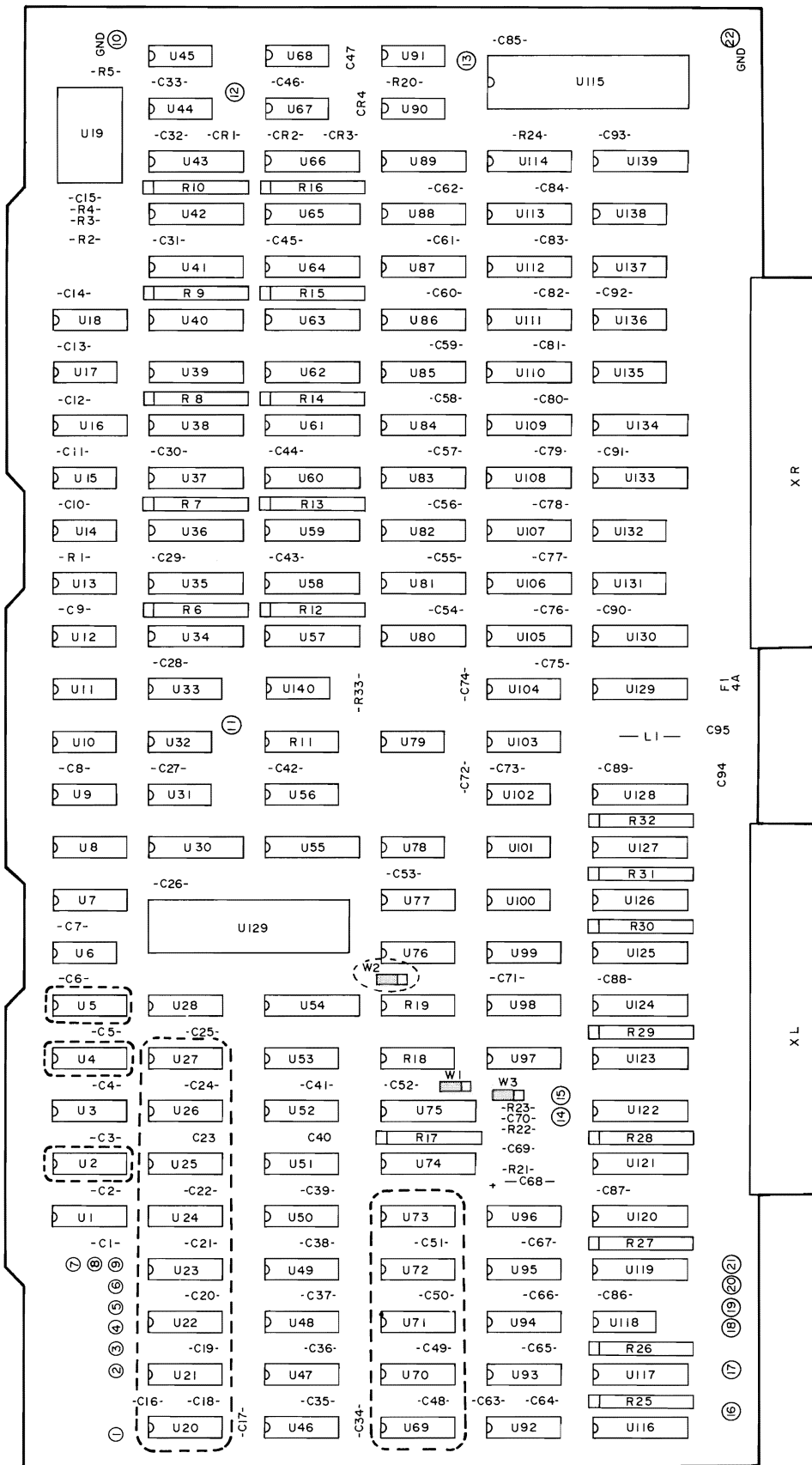

Figure 7-1. A7 Board Component Locations Changes

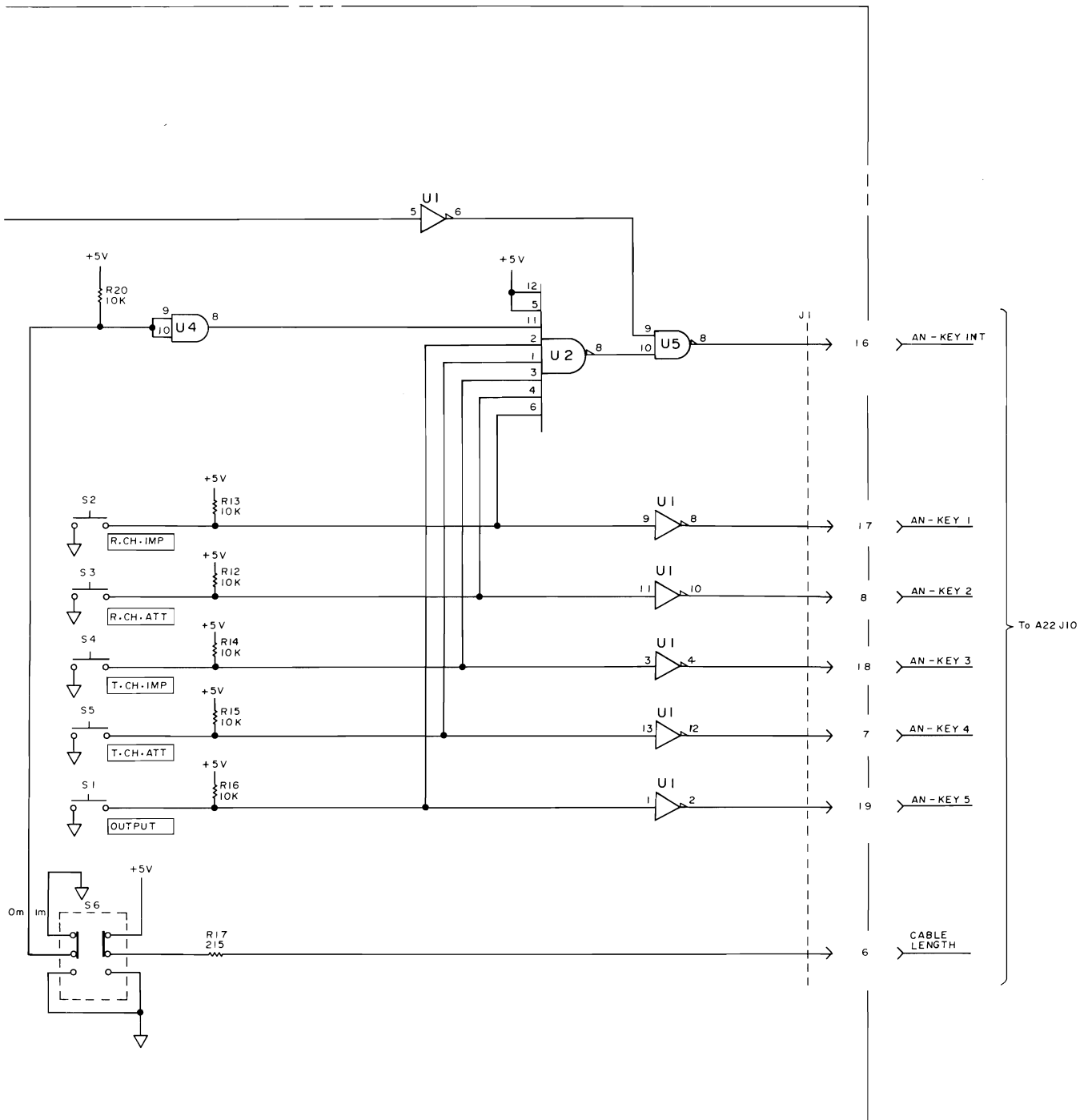

Figure 7-2. A26 Board Schematic Changes

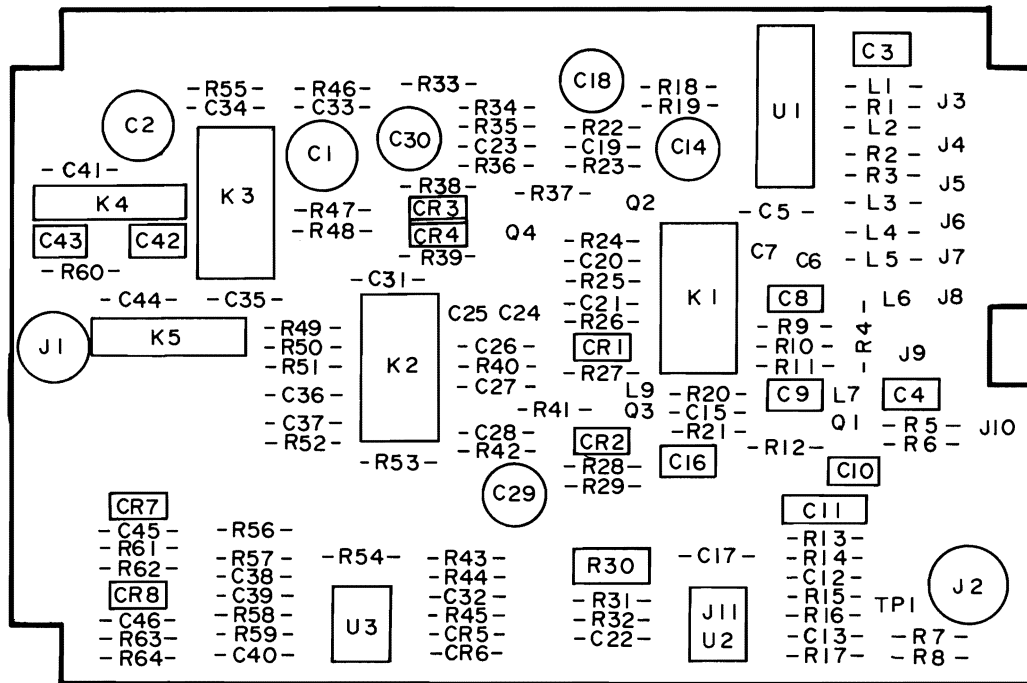

Figure 7-3. A21A1 Board Component Location Changes

A21A1 TEST CHANNEL AMPLIFIER

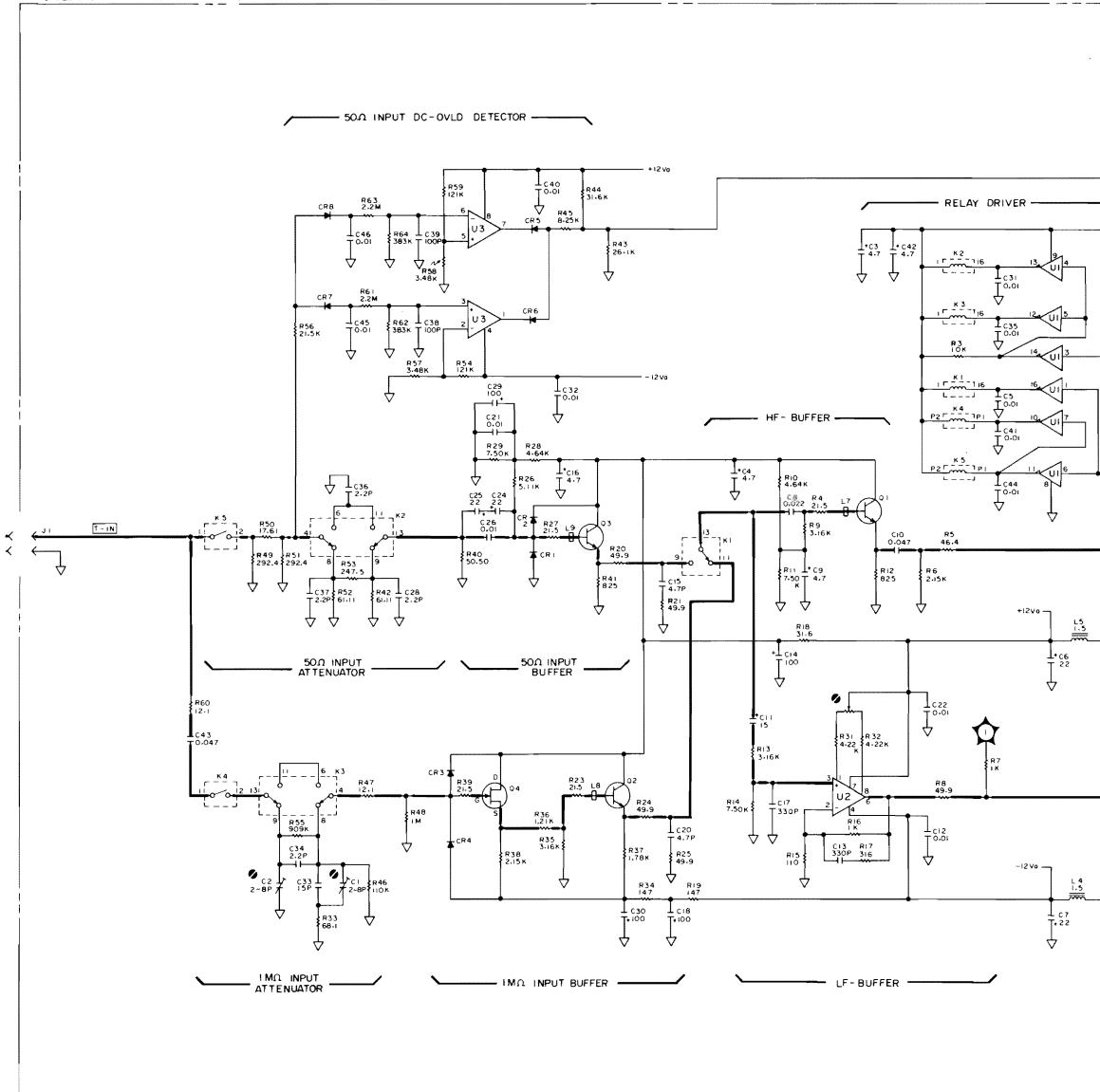

Figure 7-4. A21A1 Board Schematic Changes

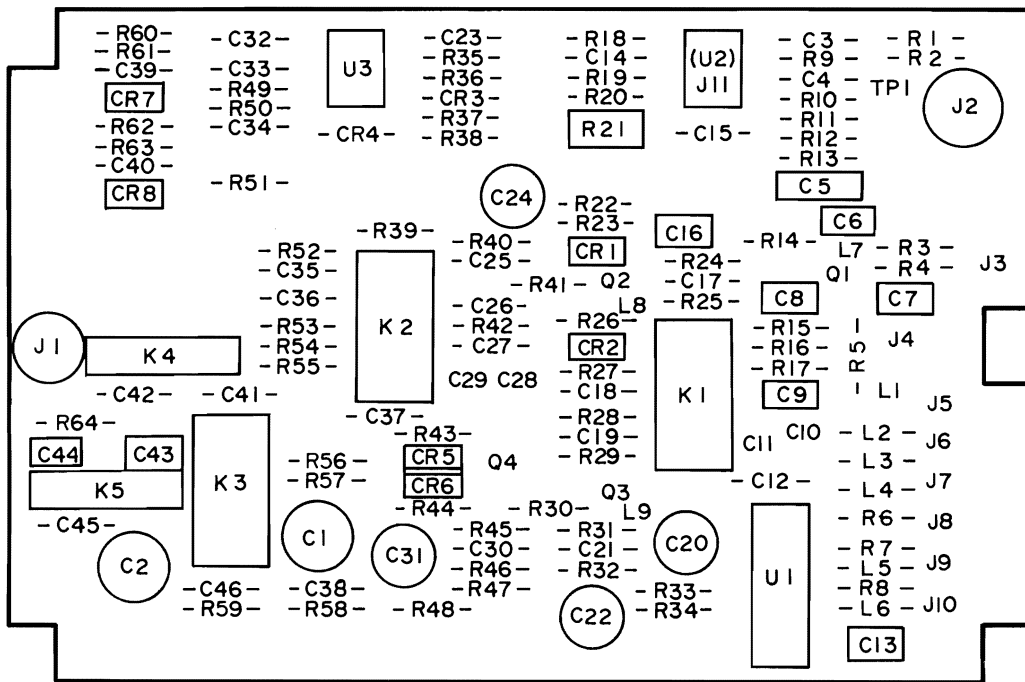

Figure 7-5. A21A2 Board Component Location Changes

A21A2 REFERENCE CHANNEL AMPLIFIER

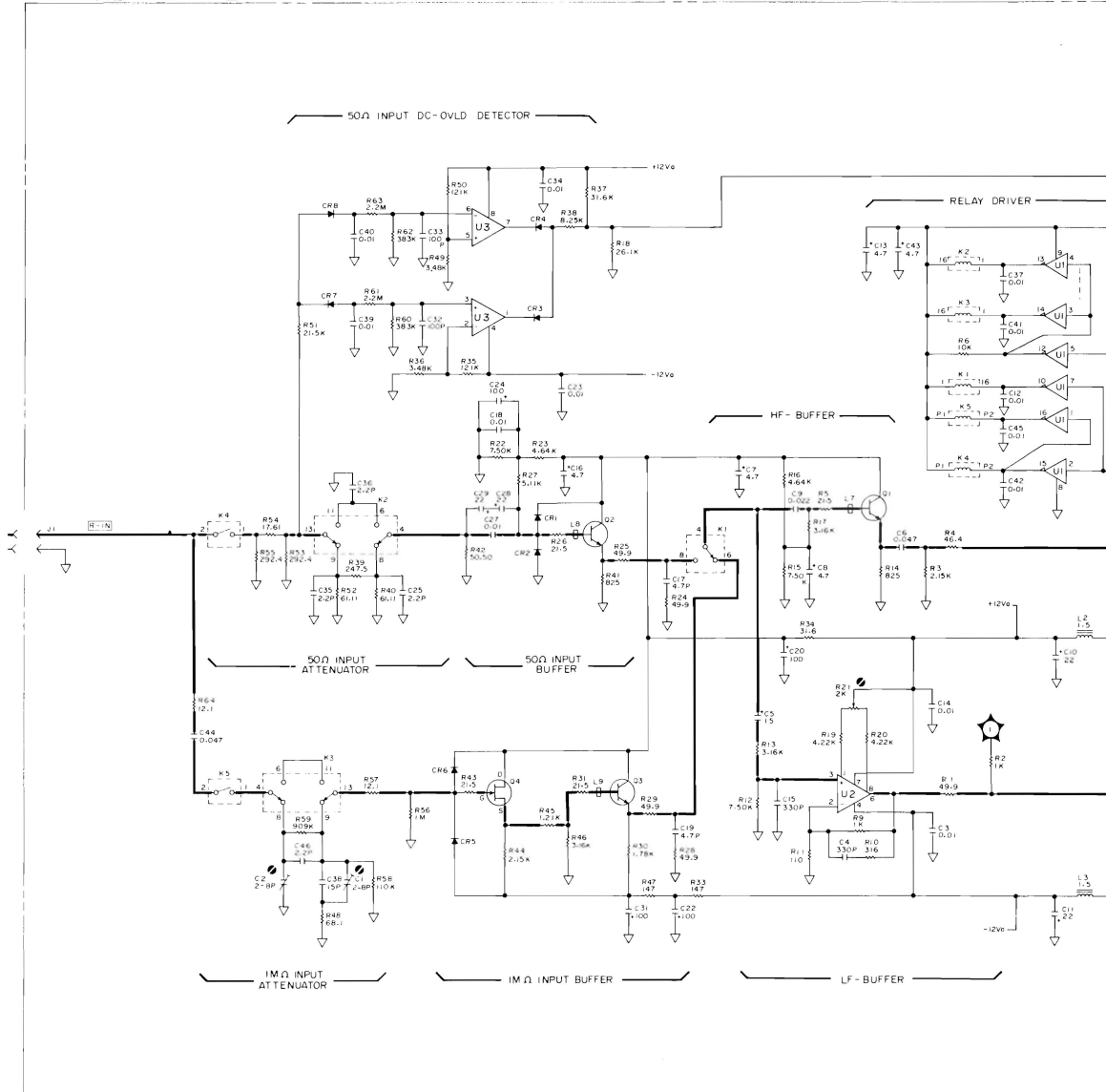

Figure 7-6. A21A2 Board Schematic Changes

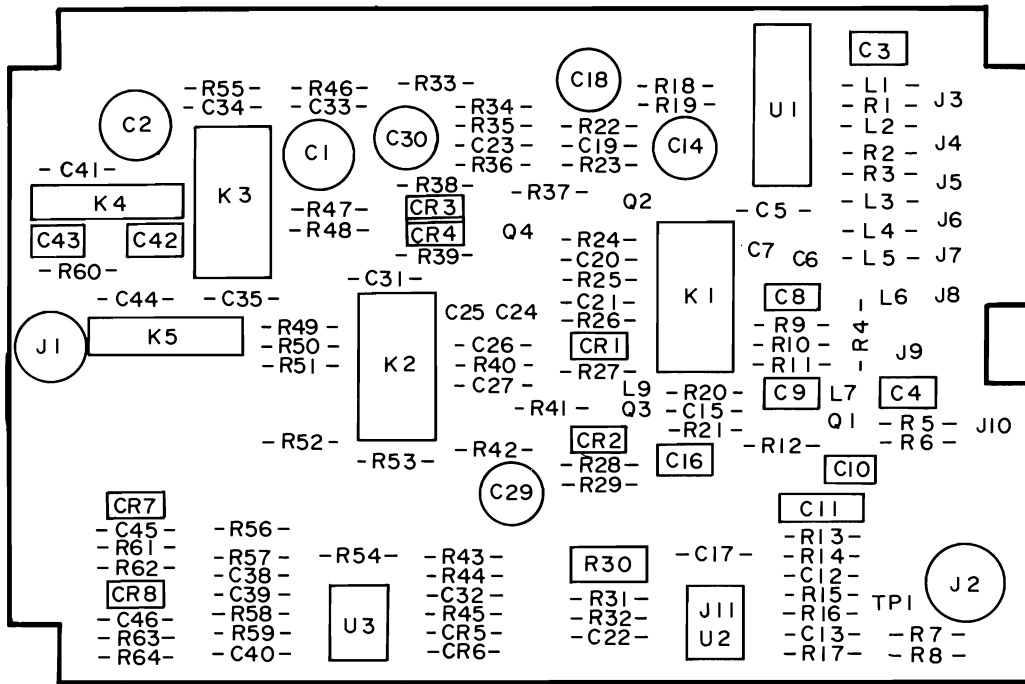

Figure 7-7. A31A1 Board Component Location Changes

A31A1 TEST CHANNEL AMPLIFIER

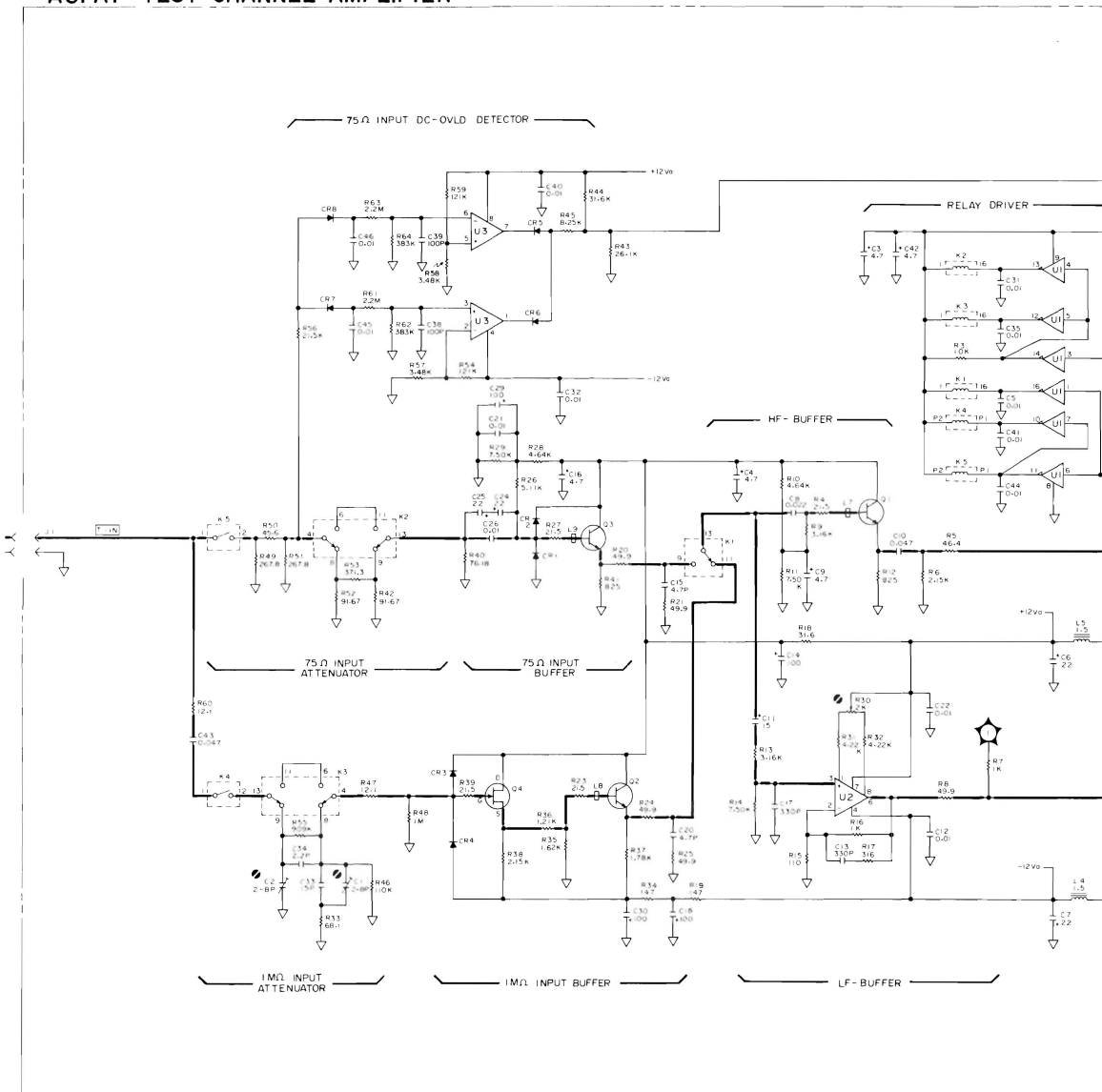

Figure 7-8. A31A1 Board Schematic Changes

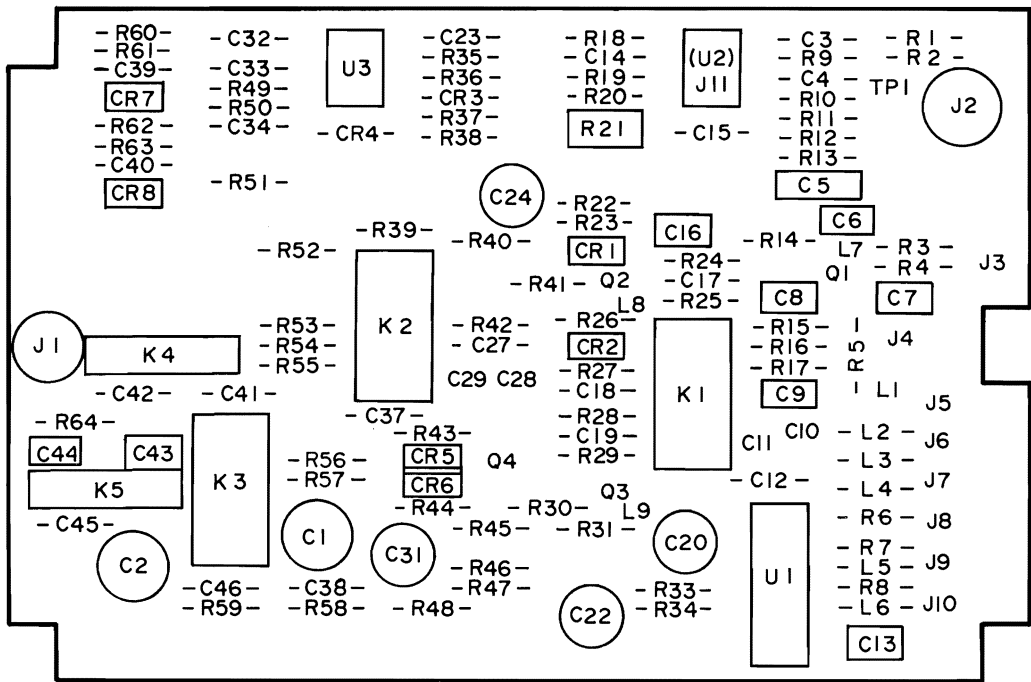

Figure 7-9. A31A2 Board Component Location Changes

A31A2 REFERENCE CHANNEL AMPLIFIER

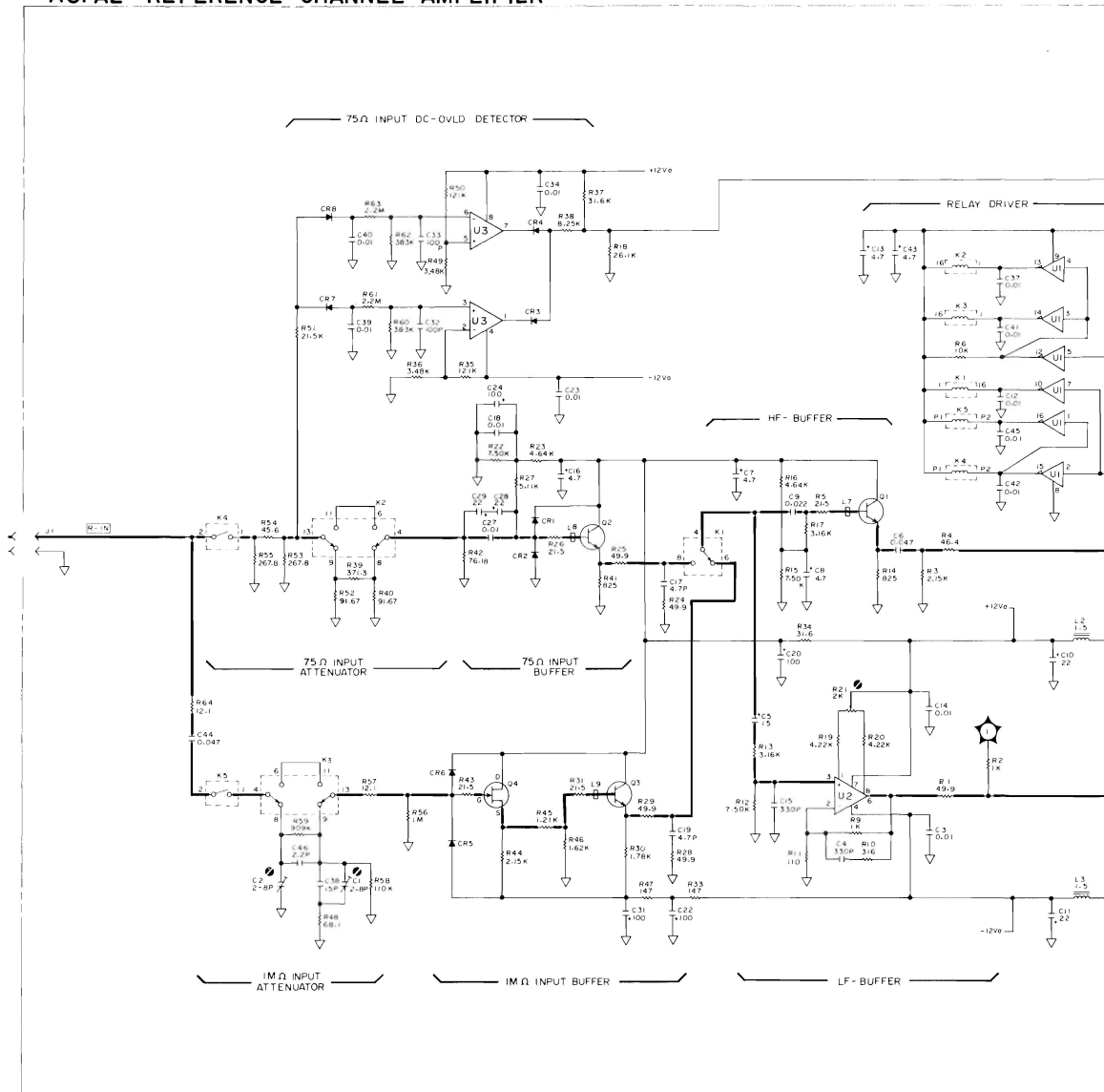

Figure 7-10. A31A2 Board Schematic Changes

Table 7-2. Parts Information (sheet 1 of 4)

CHANGE	Page	Note	Reference Designation	HP Part Number	Description
1	6-19	C	A6U4	04194-85301	PROM
			A6U5	04194-85303	PROM
			A6U6	04194-85205	PROM
			A6U7	04194-85207	PROM
			A6U8	04194-85209	PROM
			A6U9	04194-85211	PROM
			A6U10	04194-85213	PROM
			A6U11	04194-85215	PROM
			A6U12	04194-85217	PROM
		C	A6U20	04194-85302	PROM
			A6U21	04194-85304	PROM
			A6U22	04194-85206	PROM
			A6U23	04194-85208	PROM
			A6U24	04194-85210	PROM
			A6U25	04194-85212	PROM
			A6U26	04194-85214	PROM
			A6U27	04194-85216	PROM
A6U28	04194-85218	PROM			
1	6-30	C	A8U1	04194-85331	PROM
			A8U2	04194-85332	PROM
			A8U3	04194-85233	PROM
			A8U4	04194-85234	PROM
			A8U5	04194-85235	PROM
			A8U6	04194-85236	PROM
			A8U7	04194-85337	PROM
			A8U8	04194-85338	PROM
			A8U9	04194-85239	PROM
			A8U10	04194-85240	PROM
1 and 5	6-24	A	A7U2	1818-3059	64KBIT DRAM
			A7U4	1818-3059	64KBIT DRAM
			A7U5	1818-3059	64KBIT DRAM
	6-25		A7U20	1818-3059	64KBIT DRAM
			A7U21	1818-3059	64KBIT DRAM
			A7U22	1818-3059	64KBIT DRAM
			A7U23	1818-3059	64KBIT DRAM
			A7U24	1818-3059	64KBIT DRAM
			A7U25	1818-3059	64KBIT DRAM
			A7U26	1818-3059	64KBIT DRAM
	6-26		A7U27	1818-3059	64KBIT DRAM
			A7U69	1818-3059	64KBIT DRAM
			A7U70	1818-3059	64KBIT DRAM
			A7U71	1818-3059	64KBIT DRAM
A7U72	1818-3059	64KBIT DRAM			
A7U73	1818-3059	64KBIT DRAM			

Table 7-2. Parts Information (sheet 2 of 4)

CHANGE	Page	Note	Reference Designation	HP Part Number	Description	
1 and 5	6-24	C	A7U1	1818-3059	64KBIT DRAM	
	6-25		A7U3	1818-3059	64KBIT DRAM	
			A7U28	1818-3059	64KBIT DRAM	
			A7U46	1818-3059	64KBIT DRAM	
			A7U47	1818-3059	64KBIT DRAM	
			A7U48	1818-3059	64KBIT DRAM	
			A7U49	1818-3059	64KBIT DRAM	
			A7U50	1818-3059	64KBIT DRAM	
			A7U51	1818-3059	64KBIT DRAM	
			A7U52	1818-3059	64KBIT DRAM	
			A7U53	1818-3059	64KBIT DRAM	
			6-26	A7U92	1818-3059	64KBIT DRAM
				A7U93	1818-3059	64KBIT DRAM
				A7U94	1818-3059	64KBIT DRAM
				A7U95	1818-3059	64KBIT DRAM
				A7U96	1818-3059	64KBIT DRAM
3	6-81	A	A21A1C30	0180-3469	CAP FXD 100µF	
	6-81	D	A21A1C19			
			A21A1C23			
			A21A1C27			
			A21A1R22			
			A21A1R65			
	6-83	C	A21A1C24	0180-3363	CAP FXD 22µF	
			A21A1C26	0160-4832	CAP FXD .01µF	
	6-83		A21A1R23	0698-3430	RES 21.5 1% .125W	
			A21A1R35	0757-0279	RES 3.16K 1% .125	
A21A1R36			0757-0274	RES 1.21K 1% .125		
A21A1R37			0757-0278	RES 1.78K 1% .125		
A21A1R38			0698-0084	RES 2.15K 1% .125		
A21A1R39			0698-3430	RES 21.5 1% .125W		
3	6-85	D	A21A2C26			
	6-87		A21A2C30			
	6-88		A21A2R32			
			A21A2R65			
6-85	C	A21A2C27	0160-4832	CAP FXD .01µF		
		A21A2C29	0180-3363	CAP FXD 22µF		
6-87		A21A2R30	0757-0278	RES 1.78K 1% .125		
		A21A2R31	0698-3430	RES 21.5 1% .125W		
		A21A2R45	0757-0274	RES 1.21K 1% .125		
		A21A2R46	0757-0279	RES 3.16K 1% .125		

Table 7-2. Parts Information (sheet 3 of 4)

CHANGE	Page	Note	Reference Designation	HP Part Number	Description			
3	6-127	A	A31A1C30	0180-3469	CAP FXD 100 μ F			
	6-127	D	A31A1C19					
	6-129 6-130		A31A1C23 A31A1C27 A31A1R22 A31A1R65					
	6-127 6-129	C	A31A1C24	0180-3363	CAP FXD 22 μ F			
	A31A1C26		0160-4832	CAP FXD .01 μ F				
	A31A1R23		0698-3430	RES 21.5 1% .125W				
	A31A1R35		0757-3150	RES 1.62K				
	A31A1R36		0698-3150	RES 2.37K 1% .125				
	A31A1R37		0757-0278	RES 1.78K 1% .125				
	A31A1R38 A31A1R39		0698-0084 0698-3430	RES 2.15K 1% .125 RES 21.5 1% .125W				
3	6-131	D	A31A2C26					
	6-133 6-134		A31A2C30 A31A2R32 A31A2R65					
	6-131 6-133		A31A2C27 A31A2C29 A31A2R30 A31A2R31 A31A2R45 A31A2R46	0160-4832 0180-3363 0757-0278 0698-3430 0757-0274 0757-0418	CAP FXD .01 μ F CAP FXD 22 μ F RES 1.78K 1% .125 RES 21.5 1% .125W RES 1.21K 1% .125 RES 1.62K			
5	6-19	C	A6U4	04194-85401	PROM			
			A6U5	04194-85403	PROM			
			A6U6	04194-85305	PROM			
			A6U7	04194-85307	PROM			
			A6U8	04194-85309	PROM			
			A6U9	04194-85311	PROM			
			A6U10	04194-85313	PROM			
			A6U11	04194-85315	PROM			
			A6U12	04194-85317	PROM			
			5	6-19	C	A6U20	04194-85402	PROM
						A6U21	04194-85404	PROM
						A6U22	04194-85306	PROM
A6U23	04194-85308	PROM						
A6U24	04194-85310	PROM						
A6U25	04194-85312	PROM						
A6U26	04194-85314	PROM						
A6U27 A6U28	04194-85316 04194-85318	PROM PROM						

Table 7-2. Parts Information (sheet 4 of 4)

CHANGE	Page	Note	Reference Designation	HP Part Number	Description
5	6-30	C	A8U1	04194-85431	PROM
			A8U2	04194-85432	PROM
			A8U3	04194-85233	PROM
			A8U4	04194-85234	PROM
			A8U5	04194-85235	PROM
			A8U6	04194-85236	PROM
			A8U7	04194-85337	PROM
			A8U8	04194-85338	PROM
			A8U9	04194-85239	PROM
			A8U10	04194-85240	PROM

A: Add D: Delete C: Change

SECTION 8

SERVICE

8-1. INTRODUCTION

This section provides the information and instructions required to service the HP 4194A Impedance/Gain-Phase Analyzer. The theory of operation will be discussed, and a troubleshooting guide with circuit schematics are included. The Theory of Operation describes the fundamental principles of operation and the circuit theory of the 4194A at the block diagram level. The circuit schematics, locator illustrations, troubleshooting guides, circuit analysis and other technical data necessary for repairs are integrated into the service sheet fold-outs. An illustration of the interior of the instrument is shown in Figure 8-2.

8-2. SAFETY CONSIDERATIONS

This section contains **WARNINGS** and **CAUTIONS** which must be followed for your safety and to avoid damaging the equipment. Notes are included for clarification.



MAINTENANCE DESCRIBED HEREIN IS PERFORMED WITH POWER SUPPLIED TO THE INSTRUMENT AND PROTECTIVE COVERS REMOVED. SUCH MAINTENANCE SHOULD BE PERFORMED BY TRAINED SERVICE PERSONNEL ONLY.

8-3. THEORY OF OPERATION

The theory of operation is organized into three sections: basic theory, block diagram discussion, and circuit analysis. Basic theory begins with paragraph 8-14, and explains the theory of operation, the concepts, and the techniques used to accurately measure the device under test, to fully achieve automated high performance measurements. The block diagram discussion uses block-to-block signal flow analysis to describe the overall circuit operating theory of the 4194A. Block diagrams and timing information are included. Circuit analysis provides a detailed description of the function of each circuit board. A circuit description is included on each service sheet for your convenience.

8-4. RECOMMENDED TEST EQUIPMENT

The test equipment required for performing the operations outlined in this section are listed in Table 5-1. The table includes the type of instrument required, critical specifications, and model numbers for the recommended equipment. If the recommended models are not available, equipment which meets or exceeds all critical specifications may be substituted.

8-5. TROUBLESHOOTING

The troubleshooting guide is organized into two sections: isolating the trouble to the assembly level, and using service sheets to troubleshoot to the component level. How to isolate a problem to the assembly level is presented in the form of step-by-step procedures using flowcharts. The guides for locating defective components are given on the individual service-sheets. Signature analysis is employed to facilitate troubleshooting of the Digital Section.

8-6. REPAIR

The replacement of defective components is explained in Repair Explanations. The replacement procedures for special components and parts or components which require special replacement techniques, replacement tools, or test equipment should be followed. Correct disassembly and the exchange procedures for special parts are outlined in paragraphs 8-7 through 8-11. To prevent damage to the instrument, resulting from improper repair procedures, refer to the appropriate section of the manual before proceeding with any repair.

8-7. FASTENERS

The 4194A's mechanical components are secured using metric screws. Many screws in the 4194A may appear to be Phillips screws, but they are Pozidrive. Use only Pozidrive screwdrivers when removing or tightening these screws to avoid damaging them.

8-8. SCHEMATIC DIAGRAM SYMBOLS

Figure 8-1 shows the symbols used on the schematic diagrams.















	DANGEROUS VOLTAGE, EXCEEDS 1000 VOLTS
	Knob control
	Screwdriver adjustment
	Circuit assembly borderline.
	Asterisk denotes a factory selected value. Value shown is typical, part may be omitted.
	Bead inductance.
	Circuit board pattern inductance
	Heavy line indicates main signal path.
	Heavy dashed line indicates main feedback path.
	Wiper moves towards CW with clockwise rotation of control (as viewed from shaft or knob).
	Numbered test point. Measurement aid provided.
	Denotes wire color code. Code used is the same as the resistor color code (e.g., 9.4.7 denotes white/yellow/violet).
	Encloses front panel designations.
	Shielded area
	Indicates direct conducting connection to earth.
	Indicates conducting connection to chassis or frame.
	Indicates circuit common connection.

Figure 8-1. Schematic Diagram Note

8-9. ASSEMBLY DESIGNATIONS

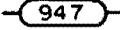
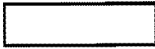
Assemblies such as printed circuit board are assigned numbers in sequence, A1, A2, etc., as shown in Table 8-1. Subassemblies within an assembly are given a subordinate A-number and a subassembly number. For example, R1 on the Test Channel Amplifier Board Assembly is designated as A21A1R1.

Table 8-1. Assembly Identification

ASSY.#	ASSY. NAME
A1	PRIMARY RECTIFIER BOARD ASSEMBLY
A2	POWER SUPPLY CONTROL BOARD ASSEMBLY
A3	POWER SUPPLY OUTPUT BOARD ASSEMBLY
A4	CRT DEFLECTION BOARD ASSEMBLY
A4A1	RC NETWORK BOARD ASSEMBLY
A5	VIDEO AMPLIFIER BOARD ASSEMBLY
A6	DATA MANIPULATION PROCESSOR BOARD ASSEMBLY
A7	GDC/RAM BOARD ASSEMBLY
A8	MEASUREMENT CONTROL PROCESSOR BOARD ASSEMBLY
A9	PHASE DETECTOR/A-D CONVERTER BOARD ASSEMBLY
A10	REFERENCE FREQUENCY GENERATOR BOARD ASSEMBLY
A11	FRACTIONAL N LOOP BOARD ASSEMBLY
A12	KEYBOARD CONTROL BOARD ASSEMBLY
A13	CONTROL UNIT KEYBOARD ASSEMBLY
A14	POWER SUPPLY MOTHERBOARD ASSEMBLY
A15	MOTHERBOARD ASSEMBLY
A16	NOT ASSIGNED
A17	CRT SOCKET BOARD ASSEMBLY
A18	NOT ASSIGNED
A19	NOT ASSIGNED
A20	RANGE RESISTOR BOARD ASSEMBLY
A21	PROCESS AMPLIFIER BOARD ASSEMBLY (OPT 350)
A21A1	TEST CHANNEL AMPLIFIER ASSEMBLY (OPT 350)
A21A2	REFERENCE CHANNEL AMPLIFIER BOARD ASSEMBLY (OPT 350)
A22	MODULATOR/FREQUENCY CONVERTER BOARD ASSEMBLY
A23	NULL DETECTOR BOARD ASSEMBLY
A24	OUTPUT AMPLIFIER BOARD ASSEMBLY (OPT 350)
A24A1	ATTENUATOR/POWER SPLITTER BOARD ASSEMBLY (OPT 350)
A25	HIGH STABILITY OSCILLATOR BOARD ASSEMBLY (OPTION 001)
A26	MEASUREMENT UNIT KEYBOARD ASSEMBLY
A31	PROCESS AMPLIFIER BOARD ASSEMBLY (OPT 375)
A31A1	TEST CHANNEL AMPLIFIER ASSEMBLY (OPT 375)
A31A2	REFERENCE CHANNEL AMPLIFIER BOARD ASSEMBLY (OPT 375)
A34	OUTPUT AMPLIFIER BOARD ASSEMBLY (OPT 375)
A34A1	ATTENUATOR/POWER SPLITTER BOARD ASSEMBLY (OPT 375)

8-10. ASSEMBLY LOCATIONS

The 4194A consists of a CONTROL UNIT and a MEASUREMENT UNIT. The control unit contains printed circuit boards A1 through A17, and the measurement unit contains PC boards A20 through A26. A31, A31A1, A31A2, A34 and A34A1 are used in place of A21, A21A1, A21A2, A24 and A24A1, respectively on Option 375 (75Ω) units.

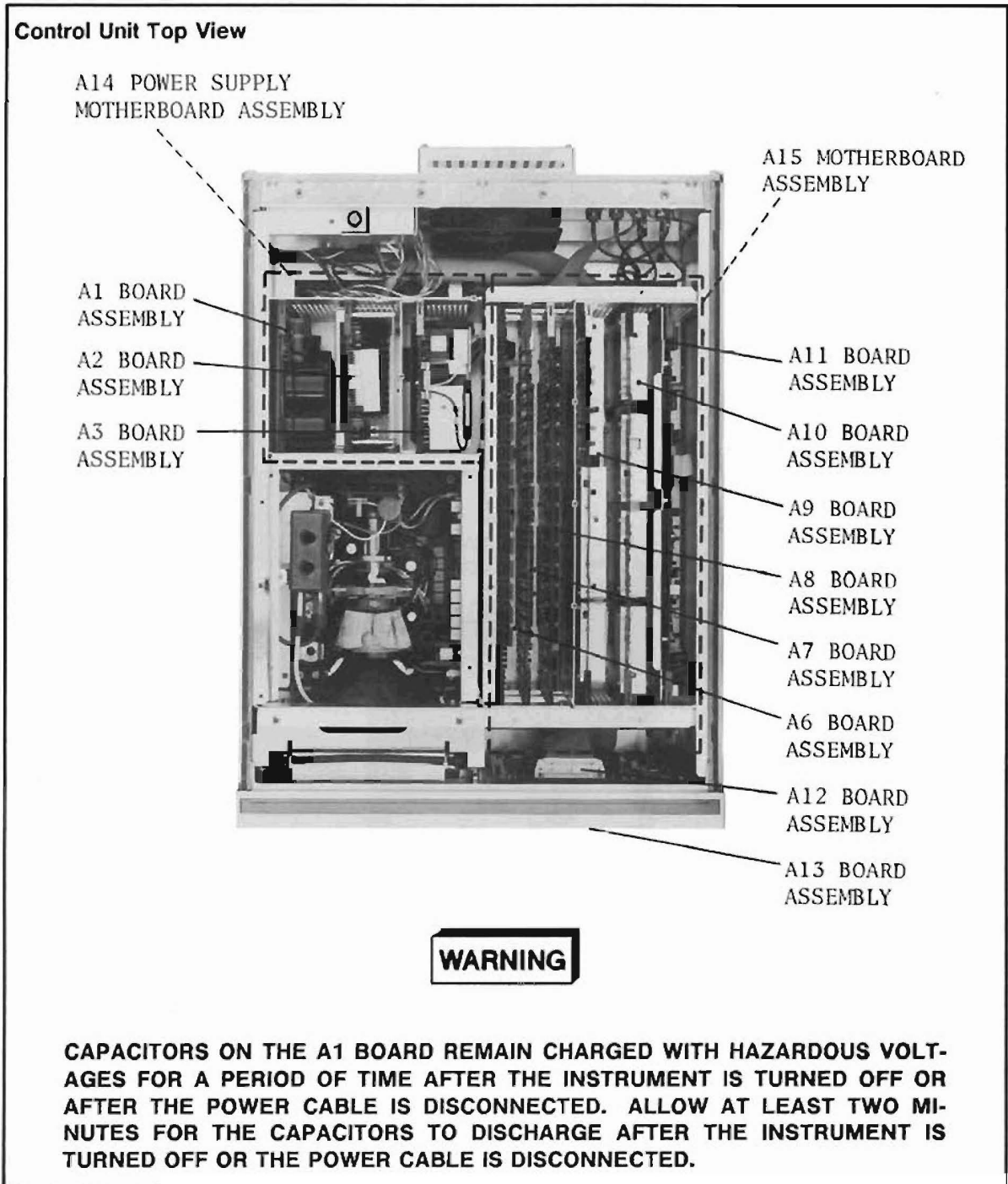
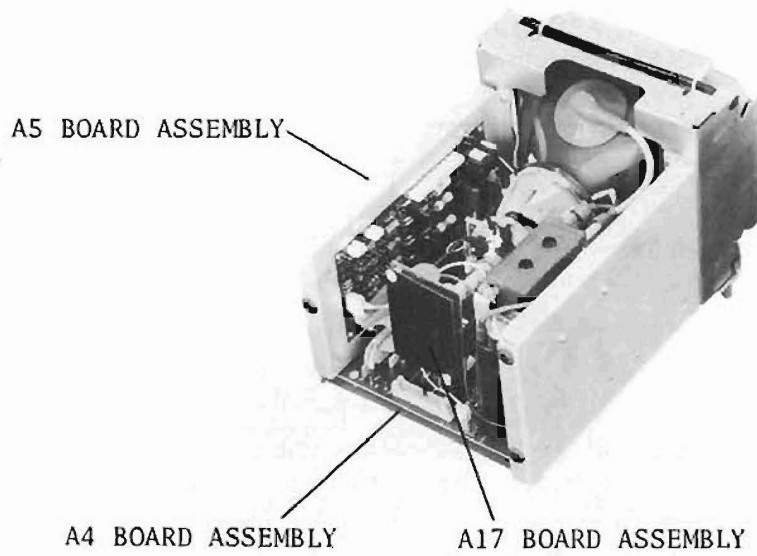

Figure 8-2. Assembly Locations (Sheet 1 of 3)

CRT Section



Measurement Unit Top View

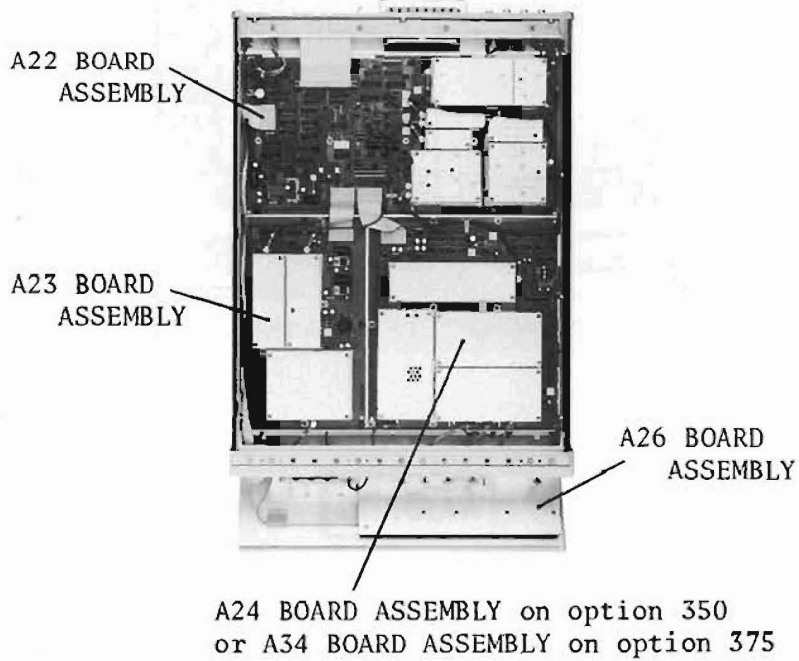

Figure 8-2. Assembly Locations (Sheet 2 of 3)

Measurement Unit Bottom View

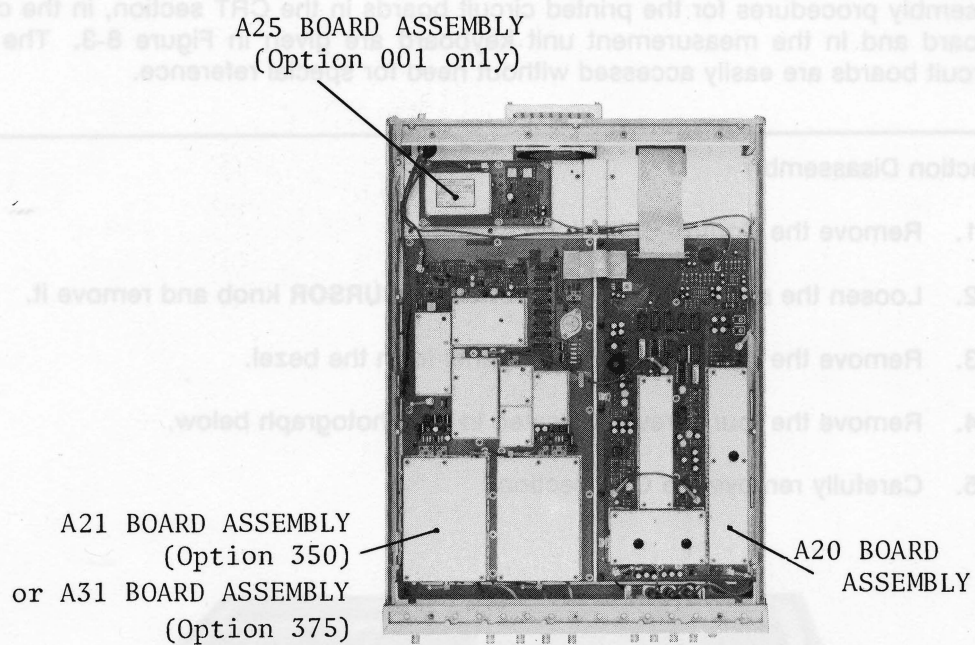

Figure 8-2. Assembly Locations (Sheet 3 of 3)

8-11. DISASSEMBLY

The disassembly procedures for the printed circuit boards in the CRT section, in the control unit keyboard and in the measurement unit keyboard are given in Figure 8-3. The other printed circuit boards are easily accessed without need for special reference.

CRT Section Disassembly

1. Remove the Control Unit's top cover.
2. Loosen the setscrews on the **MARKER/L CURSOR** knob and remove it.
3. Remove the Control Unit's front panel from the bezel.
4. Remove the four screws indicated in the photograph below.
5. Carefully remove the CRT section.

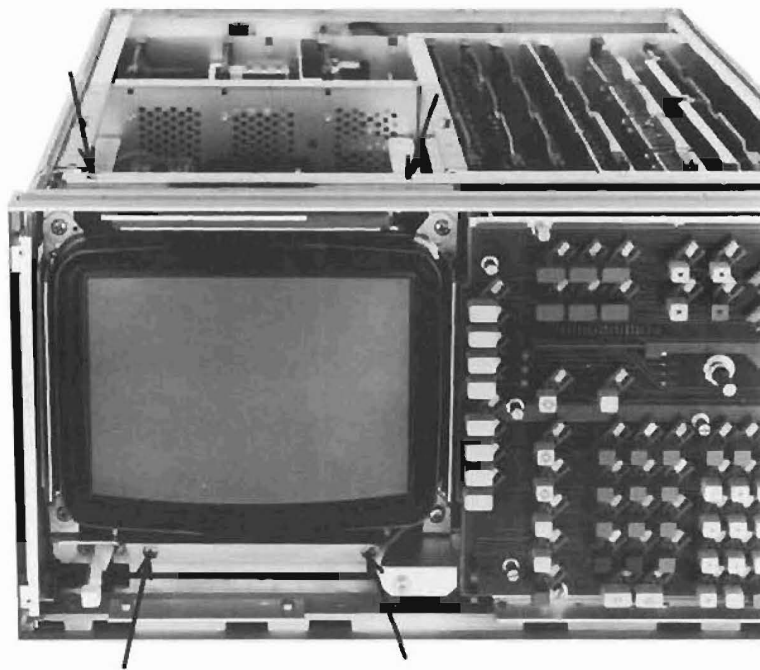

Figure 8-3. Disassembly (sheet 1 of 3)

Control Unit Keyboard Section Disassembly

1. Loosen the two hex setscrews on the **MARKER/L CURSOR** knob and remove it.
2. Remove the Control unit's front panel from the bezel.
3. Unscrew the four screws, indicated in the photograph, until they are free.

Note

These four screws are not removable.

4. Carefully remove the keyboard section.

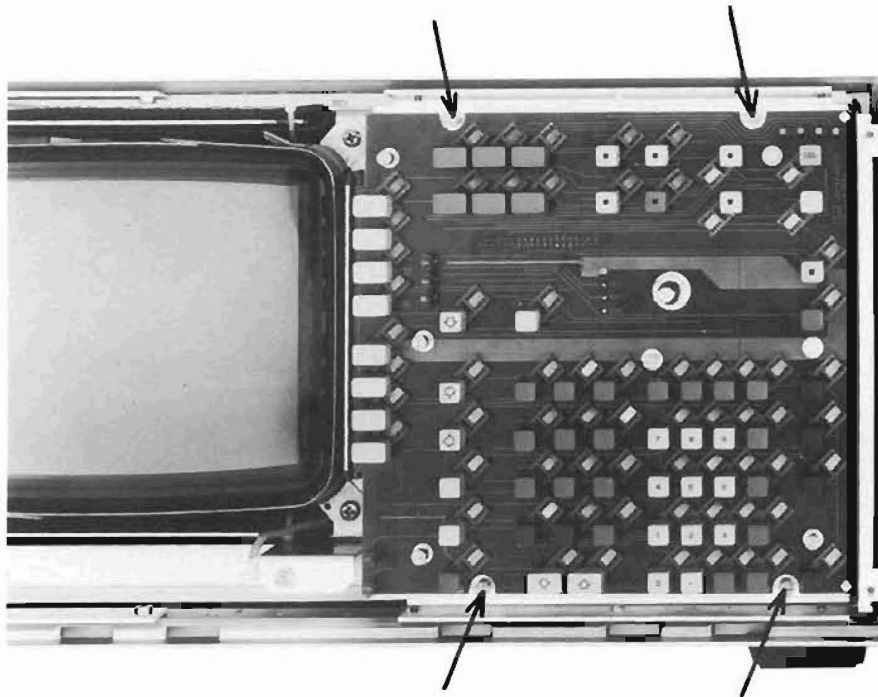

Figure 8-3. Disassembly (sheet 2 of 3)

Measurement Unit Keyboard Section Disassembly

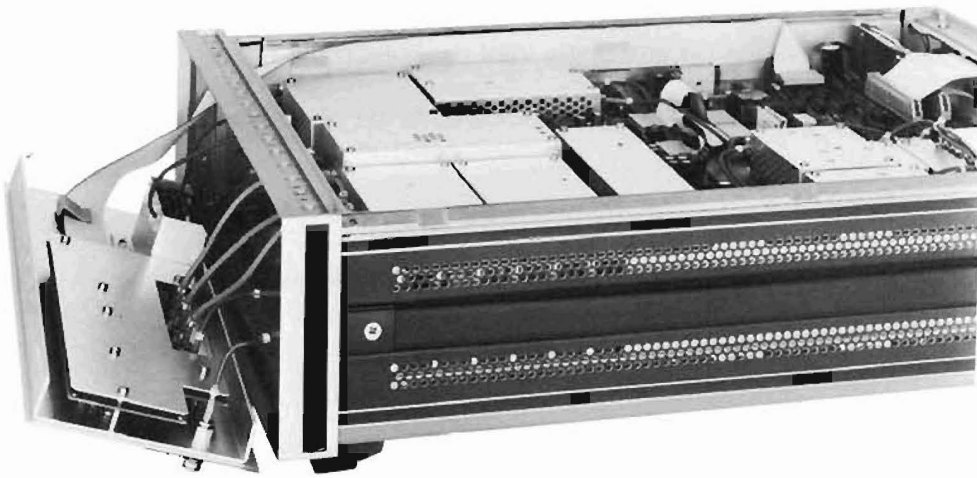

Figure 8-3. Disassembly (sheet 3 of 3)

8-12. PRODUCT SAFETY CHECKS

WARNING

WHENEVER IT APPEARS LIKELY THAT SAFETY PROTECTIVE PROVISIONS HAVE BEEN IMPAIRED, THE APPARATUS SHALL BE MARKED AS INOPERATIVE AND SHOULD BE SECURED AGAINST ANY UNINTENDED OPERATION. THE PROTECTION PROVISIONS WILL HAVE LIKELY BEEN COMPROMISED IF, FOR EXAMPLE:

- INSTRUMENT SHOWS VISIBLE DAMAGE.
- THE INSTRUMENT FAILS TO PERFORM THE INTENDED MEASUREMENT.
- THE UNIT HAS UNDERGONE PROLONGED STORAGE UNDER UNFAVORABLE CONDITIONS.
- THE INSTRUMENT WAS SEVERELY STRESSED IN TRANSPORT.

Perform the following five checks to verify the safety of the 4194A (these checks may also be used to check for safety after troubleshooting and repair).

1. Visually inspect the interior of instrument for any signs of abnormal internally generated heat, such as discolored printed circuit boards or components, damaged insulation, or evidence of arcing. Determine the cause and repair.
2. Use an ohmmeter capable of accurately measuring 0.5Ω to check the resistance from instrument enclosure to the power cord's ground pin. The resistance must be less than 0.5Ω . Flex the power cord while making this measurement to determine if any intermittent discontinuities exist.
3. Check the GUARD terminal on front panel using the procedure outlined in step 2.
4. Disconnect the instrument from its power source. Turn on the power switch. Tie the line and neutral pins of the power connector together and check the resistance between them and the instrument's enclosure. The minimum acceptable resistance is 2Ω . Find and replace any component which causes the instrument to fail this test.
5. Verify that the correct fuse is installed.

8-13. SIGNAL NAMES

Signal names and their meaning as used in the 4194A are listed in Table 8-2.

Table 8-2. Signal Names

SIGNAL NAME	FROM	TO	MEANING
ACLKB	A6U58-3	A7/A8	10MHz clock for CPU B
AC-OVLD-R	A21U8-12	A22U40-3	REFERENCE Channel AC Overload
AC-OVLD-T	A21U7-12	A22U40-8	TEST Channel AC Overload
AN-KEY1	A26U1-8	A8783-2	REFERENCE Channel IMPEDANCE select key
AN-KEY2	A26U1-10	A8783-17	REFERENCE Channel ATTENUATION select key
AN-KEY3	A26U1-4	A8U83-4	TEST Channel IMPEDANCE select key
AN-KEY4	A26U1-12	A8U83-15	TEST Channel ATTENUATION select key
AN-KEY5	A26U1-2	A8U83-6	OUTPUT (SINGLE/DUAL) select key
AN-KEY-INT	A26U5-8	A8U86-9	Measure. Unit keyboard interrupt
AN-OVLD-INT	A21U6-4	A8U86-12	50Ω INPUT dc overload interrupt
ATN	A7U138-13	HP-IB	HP-IB Attention line
B1-VIDEO	A7U134-14	A5U1-3	Video Signal Blue, Low
B2-VIDEO	A7U134-17	A5U1-5	Video Signal Blue, High
BASA	A6U38-15	A7U101-13	Buffered Address-Strobe for CPU A
BASB	A8728-13	A7U101-2	Buffered Address-Strobe for CPU B
BCLKB	A6U58-5	A8U35-3	5MHz clock for CPU B
BEEPER	A6U55-10	A12U1-1	Beeper control
BIAS-L	A8U61-12	A22U30-9	Lower Byte of Bias Voltage data (serial)

Table 8-2. Signal Names (continued)

SIGNAL NAME	FROM	TO	MEANING
BIAS-U	A8U61-13	A22U29-8	Upper Byte of Bias Voltage data (serial)
BIAS-ON	A24U12-15	A26U5-1	BIAS ON lamp drive
BIAS-OVLD-D	A23Q1	A22U20-9	Bias Sink Current Overload
BIAS-OVLD-S	A24U7-10	A22U20-10	Bias Source Current Overload
BLDSA	A6U38-11	A7U127-7	Buffered Lower Data Strobe for CPU A
BLDSB	A8U28-15	A7U128-7	Buffered Lower Data Strobe for CPU B
BRG-UNBAL	A23U5-1	A22U22-1	Bridge Unbalance Detector output
BRG-UNBAL-DET	A22U22-6	A8U82-11	Bridge Unbalance Detect signal
BR/WA	A6U38-13	A7U127-8	Buffered R/W signal for CPU A
BR/WB	A8U28-12	A7U128-8	Buffered R/W signal for CPU B
BUDSA	A6U38-17	A7U127-6	Buffered Upper Data Strobe for CPU A
BUDSB	A8U28-14	A7U128-6	Buffered Upper Data Strobe for CPU B
B-ABSB	A8U46-11	A22U30-2	Bias Absorb
B-AC-OVLD-R	A22U40-17	A8U82-4	Buffered AC-OVLD-R Signal
B-AC-OVLD-T	A22U40-12	A8U82-15	Buffered AC-OVLD-T Signal
B-BIAS-L	A22U30-11	A24U13-8	Buffered BIAS-L serial data
B-BIAS-U	A22U29-12	A24U14-8	Buffered BIAS-U serial data
B-B-ABSB	A22U30-18	A20/A23	Buffered B-ABSB Signal
B-CMDT	A22U33-14		Buffered CMDT serial data
B-DC-OVLD-R	A22U40-13	A8U82-2	Buffered DC-OVLD-R Signal
B-DC-OVLD-T	A22U40-18	A8U82-17	Buffered DC-OVLD-T Signal
B-DC-V-OVLD	A22U40-14	A8U82-8	Buffered DC-V-OVLD Signal

Table 8-2. Signal Names (continued)

SIGNAL NAME	FROM	TO	MEANING
B-FOD	A22U33-17		Buffered FOD Signal
B-GP-RNG	A22U33-18	A21W1	Buffered GP-RNG Signal
B-IF-OVLD	A22U40-16	A8U82-6	Buffered IF-OVLD Signal
B-IF-SW	A22U30-16		Buffered IF-SW serial data
B-IO-ATT	A22U33-13	A21U2-8	Buffered IO-ATT serial data
B-LCL/RMT	A22U29-13	A26U1-5	Buffered LCL/RMT Signal
B-LVL-ATT	A22U33-11	A20/A24	Buffered LVL-ATT Serial data
B-MPX-RV	A22U30-15	A20/A21	Buffered MPX-RV Signal
B-MPX-TI	A22U33-16	A20/A21	Buffered MPX-TI Signal
B-OVLD-CLR	A22U33-15	A21U4/U5	Buffered OVLD-CLR Signal
B-ZT-RNG	A22U33-12	A20/A23	Buffered ZT-RNG Serial data
CABLE-LENGTH	A26S6	A8U83-8	CABLE LENGTH Im/0m
CCLKB	A6U58-7	A87/A8/A12	1.25MHz clock for CPU B
CHR-ATT	A22U32-13	A26U3/U7	REF. Chan. ATTENUATION indicator
CHR-OVLD	A22U21-6	A26U4-5	REF. Chan. OVERLOAD indicator
CHR-ZIN	A22U32-12	A26U4/U7	REF. Chan. IMPEDANCE indicator
CHT-ATT	A22U32-10	A26U3/U7	TEST Chan. ATTENUATION indicator
CHT-OVLD	A22U21-3	A26U3-1	TEST Chan. OVERLOAD indicator
CHT-ZIN	A22U32-6	A26U5/U7	TEST Chan. IMPEDANCE indicator
CMDT	A8U46-18		Common Serial Data
CNTRL	A13S22	A12U18-3	GREEN (control) key
COARSE-CLK	A8U44-15	A9U11	Multi-slope A-D Coarse clock
CPUAIN	A6U18-2	A8U52-12	CPU B Interrupt from CPU A
CPUBINT	A8U69-8	A6U51-13	CPU A Interrupt from CPU

Table 8-2. Signal Names (continued)

SIGNAL NAME	FROM	TO	MEANING
CTROUT	A6U32-13	A12U13-5	Key Repeat Counter Out
CTR-GATE	A12U13-19	A6U32-14	Key Repeat Counter Gate
C-GATE-0	A9711-8	A8U43-14	Coarse Counter Gate, 0° A-D
C-GATE-90	A9U11-6	A8U44-14	Coarse Counter Gate, 90° A-D
DAV	A7U137-11	HP-IB	HP-IB Data Valid line
DCLKB	A6U58-9	A8U53-13	5MHz/256 clock for CPU B
DC-OVLD-R	A21U3-8	A22U40-7	REF. Chan. DCV Overload
DC-OVLD-T	A21U3-4	A22U40-2	TEST Chan. DCV overload
DC-V-OVLD	A20Q5/Q6	A22U40-6	UNKNOWN H_{pot} DCV Overload
DIO1-4	A7U135	HP-IB	HP-IB DIO line
DIO5-8	A7U136	HP-IB	HP-IB DIO line
DSCPUAINT	A8U62-14	A6U19-10	Disables interrupt from CPU A
DSCPUBINT	A6U55-11	A8U70-10	Disables interrupt from CPU B
DSOSCG	A7U18-9	A7U45-3	Disables GDC clock
DSREF	A7	A7W3	Disables DRAM refresh
ENMAPRAM	A6U39-10	A7U32-9	Enables Color Map RAM
ENSHRAMA	A6U39-5	A7U101-13	Enables Shared RAM for CPU A
ENSHRAMB	A8U26-7	A7U101-1	Enables shared RAM for CPU B
EQC	A9U15-12	A8U56-9	End of A-D conversion
EOD	A8U46-17		End of analog control serial Data
EOI	A7U137-3	HP-IB	HP-IB End or Identify line
EOM	A8U77-12	8BIT I/O	End of Measurement
EOS	A8U77-11	8BIT I/O	End of Sweep
EOSC-LED	A12U2-8	A13DS15	EXT REF indicator drive signal
EULK-LED	A12U2-11	A13DS16	UNLOCK indicator drive signal

Table 8-2. Signal Names (continued)

SIGNAL NAME	FROM	TO	MEANING
EXT-LCK	A10U21-4	A8/A12	80MHz VCXO locked with EXT-REF
EXT-UNLCK	A10U12-2	A8/A12	80MHz VCXO unlocked from EXT-REF
FNCTN	A8U46-16	A22U30-3	Function serial data
FN-DO ~ 3	A8U24	A11U12	Fractional N chip data bus
FN-ECLK	A8U22-14	A11U12-26	Fractional N external clock
FN-INV	A8U22-13	A11U2-12	Fractional N Instruction Valid
FN-UNLCK	A11U35-6	A8U81-4	Fractional N Loop Unlock
F-BAND	A20U10-6	A21	Frequency > 30kHz or not
F-GATE-0	A9U15-15	A8U43-16	Fine Counter Gate, 0° A-D
F-GATE-90	A9U10-15	A8U44-16	Fine Counter Gate, 90° A-D
GDC	A6U55-7	A7U32-10	GDC Chip Select
GI-VIDEO	A7U134-9	A5U1-13	Video Signal Green, Low
G2-VIDEO	A7U134-11	A5U1-1	Video Signal Green, High
GP-RNG	A8U68-14	A22U33-2	GAIN-PHASE MEASURE. RANGE
HALTNB	A6U40-8	A8U31-17	
HPIB-INT	A7U91-8	A6U62-7	HP-IB INTERRUPT
HPIB-SELECT	A6U55-13	A7U90	ENABLES HP-IB CHIP
HSYNC	A7U7-11	A4U4-13	Horizontal SYNC
IFC	A7U138-11	HP-IB	HP-IB Interface Clear line
IF-AUTO-ZERO	A8U65-13	A9W8	Phase detector's auto-zero control
IF-OXC-UNLCK	A10U4-3	A8U81-15	80MHz-IF/2 VCXO unlock
IF-OVLD	A21U3-10	A22U40-4	IF signal overload
IF-SW	A8U46-15		IF switch serial data
IO-ATT	A8U46-13	A22U33-7	Input imp./atten. serial data

Table 8-2. Signal Names (continued)

SIGNAL NAME	FROM	TO	MEANING
BDAO ~ 7	A6U77	8BIT I/O	8 BIT INPUT/OUTPUT input line
IORESETA	A6U51-6	A7/A12	Resets CPU A Peripheral
I-TIME	A8U43-10	A9U10/U15	Integration time
KEYINT	A12U14-12	A6U62-13	Keyboard Interrupt
KEY1	A13U18	A12U14-2	Keyboard Acknowledge
KEY2	A13S23	A12U14-3	Keyboard Acknowledge
KEY3	A13S17	A12U14-5	Keyboard Acknowledge
KEY-SELECT	A6U55-15	A12	Enables keyboard control chip
LAMP-TEST	A22U23-5	A26U3-12	Lamp test
LCL/RMT	A8U68-18	A22U29-7	LOCAL/REMOTE
LED-A-1 ~ 2	A12Q3/Q4	A13	LED matrix Anode drive
LED-K1 ~ 7	A12R17	A13	LED matrix Cathode drive
LVL-ATT	A8U61-14	A22U33-9	Oscillator level attenuator control
LVL-L	A8U61-15	A22U30-8	Low Byte of Oscillator Level Data
LVL-U	A8U61-16	A22U29-8	High Byte of Oscillator Level Data
MPX-RV	A8U65-12	A22U30-5	Multiplexer REF/V channel
MPX-TI	A8U65-11	A22U33-4	Multiplexer TEST/I channel
NDAC	A7U37-13	HP-IB	HP-IB Not Data Accepted line
NRFD	A7U137-5	HP-IB	HP-IB Not Ready for Data line
OPT-OVEN	A25J2	A8U81-13	Option 001 INSTALLED
OPT-75	A24J1	A8U81-8	Option 350/375
OUTO ~ 7	A6U76	8BIT I/O	IBIT INPUT/OUTPUT OUTPUT line
OVLD-CLR	A8U68-15	A22U33-5	Overload clear
PHS-SHFTR-1~4	A8U65	A9U17	Phase detector ref. phase control

Table 8-2. Signal Names (continued)

SIGNAL NAME	FROM	TO	MEANING
PH-TRACK	A8U46-14	A22U30-7	PHASE-TRACK data
R1-VIDEO	A7U134-3	A5U1-9	Video Signal Red. Low
R1-VIDEO	A7U134-6	A5U1-11	Video Signal Red, High
REN	A7U138-5	HP-IB	HP-IB Remote Enable line
RESETB	A6U40-6	A8U31-18	
PLO - 7	A13 keys	A12U11	Keyboard scan return lines
RPG	A6U55-14	A12U5-10	
RPG-INT	A12U18-10	A6U62-8	Interrupt from RPG
RPGU/D	A12U18-8	A6U2-2	RPG rotation CW/CCW
PRG(901)	A13PRG	A12U6-2	
PRG(902)	A13PRG	A12U4-14	
SELF-TEST	A22U23-11	A21U6-2	
SHRAMDTACKA	A7U127-11	A6U51-2	Shared RAM data acknowledge for CPU A
SHRAMDTACKB	A7U128-11	A8U52-10	Shared RAM data acknowledge for CPU B
SLCK	A13S21	A12U18-5	BLUE (shift lock) key
SLCK-LED	A12U12-6	A13DS14	BLUE (shift lock) indicator
SPLTR	A22U32-3	A24/A26	OUTPUT SINGLE/DUAL
SRQ	A7U138-3	HP-IB	HP-IB Service Request line
TH-SHUT-DWN	A20ST1	A3Q1	THERMAL SHUT DOWN
UNBAL-RESET	A8U68-16	A22U29-6	Resets bridge unbalance detector
UNLCK-STATE	A10/A11	A8U81-6	VCXO/VCO frequency high/low
VSYNC	A7U7-6	A4/A6	Vertical SYNC
ZT/GP	A22U23-3	A20/A24	IMPEDANCE/GAIN-PHASE
ZT-RNG	A8U61-17	A22U33-8	Impedance measurement range serial data

8-14. BASIC OPERATING THEORY

The following description explains the measurement principles of the HP 4194A Impedance/Gain-Phase Analyzer. State-of-the-art design techniques used for automatic LCR measurement instruments and high performance signal generators were used to meet the design goals of the 4194A. It is important to have a sound understanding of the basic concepts and operating principles before advancing to the 4194A's circuit operating theory. The basic operating theory described in the following paragraphs will provide you with an in-depth understanding of the 4194A's circuits.

8-15. IMPEDANCE MEASUREMENT THEORY

VOLTAGE-CURRENT RATIO MEASUREMENT METHOD

The impedance measurement function of the 4194A is based on calculating the impedance using the values obtained by measuring the voltage-current of the Device Under Test. See Figure 8-4.

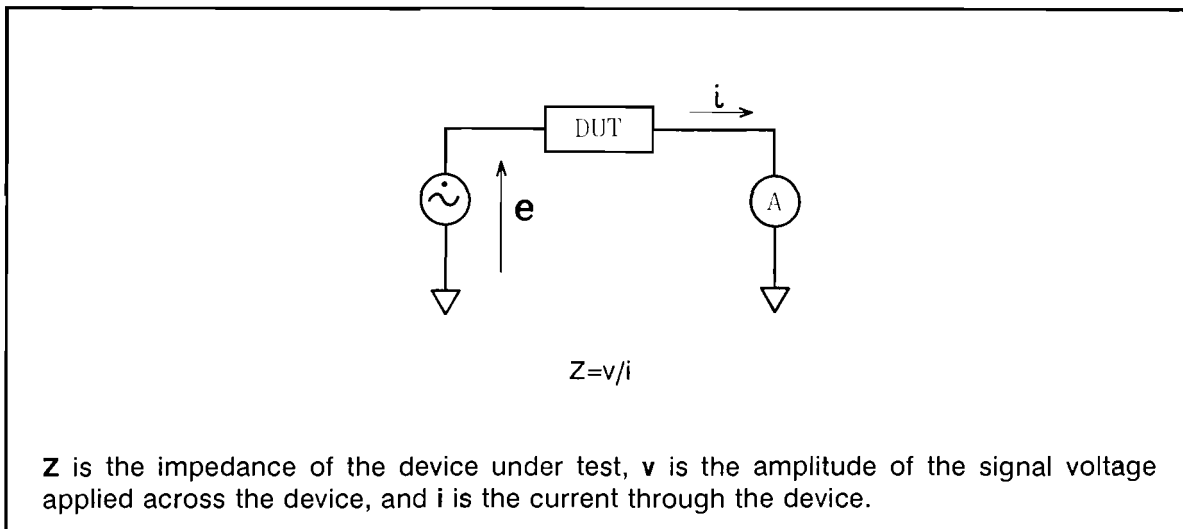

Figure 8-4. Voltage-Current Ratio Measurement Method

8-16. AMMETER CIRCUIT

One way to determine the current through a device under test is to use a current-to-voltage (I-V) converter, and is frequently used for low frequency applications. See Figure 8-5. For the range over which the ratio of an op-amp's open-loop to closed-loop gain is high, the feedback input node is held at virtual ground. The current flowing through the device under test is equal in amplitude and opposite in phase to the current flowing through the feedback resistor. When the input and the feedback currents are summed at the input node, the resultant potential is zero. Therefore the output voltage of the converter is proportional to the product of the current through the device under test and the value of the feedback resistor (R_R) used as the range resistor.

One result of the current-to-voltage converter's input being held at virtual ground is that the test signal level to the device under test is held constant, independent of the value of the feedback resistor. The bandwidth of the current-to-voltage converter, over which a flat gain-phase characteristic can be achieved, determines the frequency limitations of this method. This method does not lend itself well to high frequency impedance measurements due to the difficulty involved in achieving a broad bandwidth high open-loop gain amplifier.

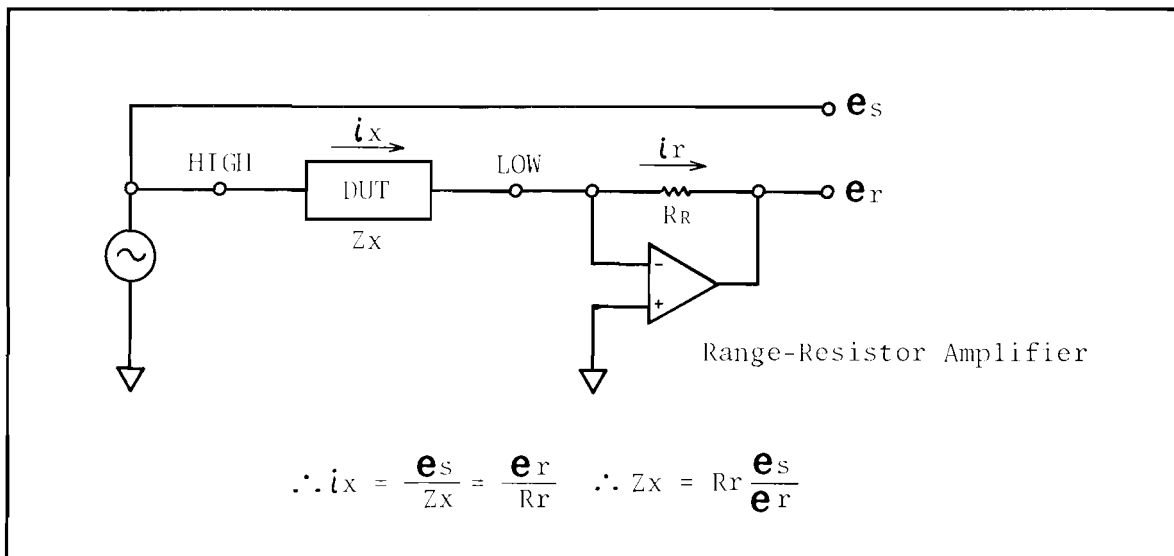

Figure 8-5. Current-To-Voltage Conversion Method

8-17. AUTO-BALANCE BRIDGE CIRCUITRY

The auto-balancing bridge circuitry used in the 4194A ensures that the vector voltage across the feedback resistor will be an accurate proportional representation of the current through the device under test, over the 4194A's full impedance measurement frequency range. The usable range of the voltage-current ratio measurement method can be extended to 40MHz.

The basic principle of the auto-balancing bridge circuit is explained in terms of the two-oscillator model illustrated in Figure 8-6. If an oscillator's amplitude and phase are adjusted to equal the frequency of the test source is used to zero the input current of the null detector, then the current flowing through the range resistor (i_r) will equal the current flowing through the device under test (i_x). The current through the device under test (i_x) is calculated by dividing the output voltage of the variable amplitude-phase oscillator (e_r) by the value of the range resistor (R_r). A vector generator is used in place of a variable amplitude-phase oscillator. See Figure 8-7. A brief description of the operating principles of the auto-balancing bridge circuitry is provided in Figure 8-8.

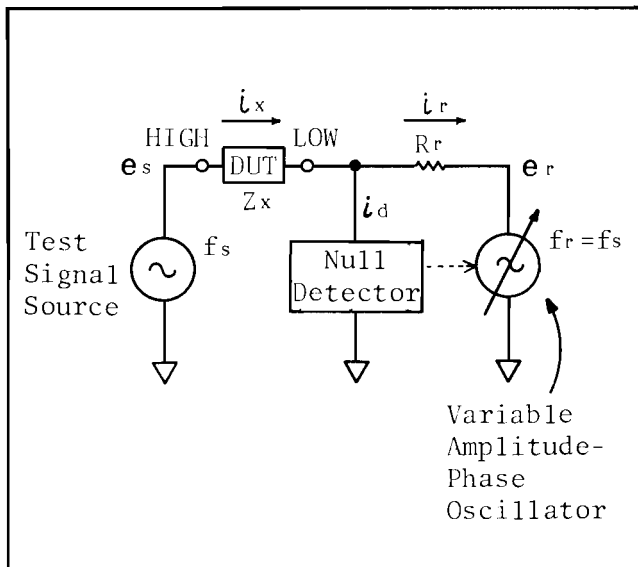

Figure 8-6. Two Oscillator Model of the Auto-Balance Bridge

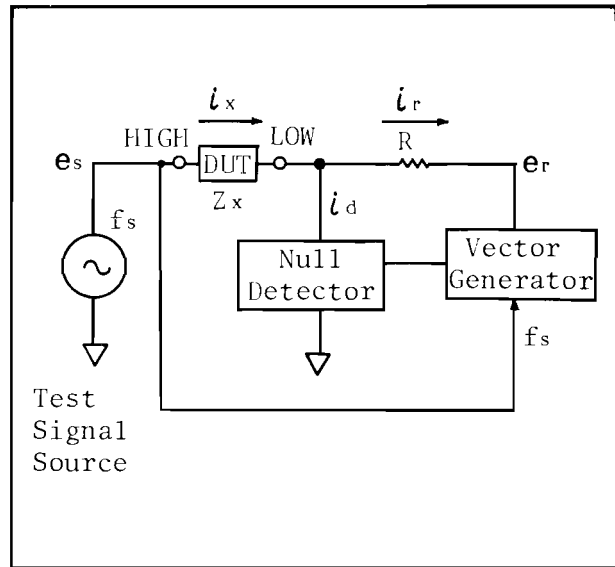
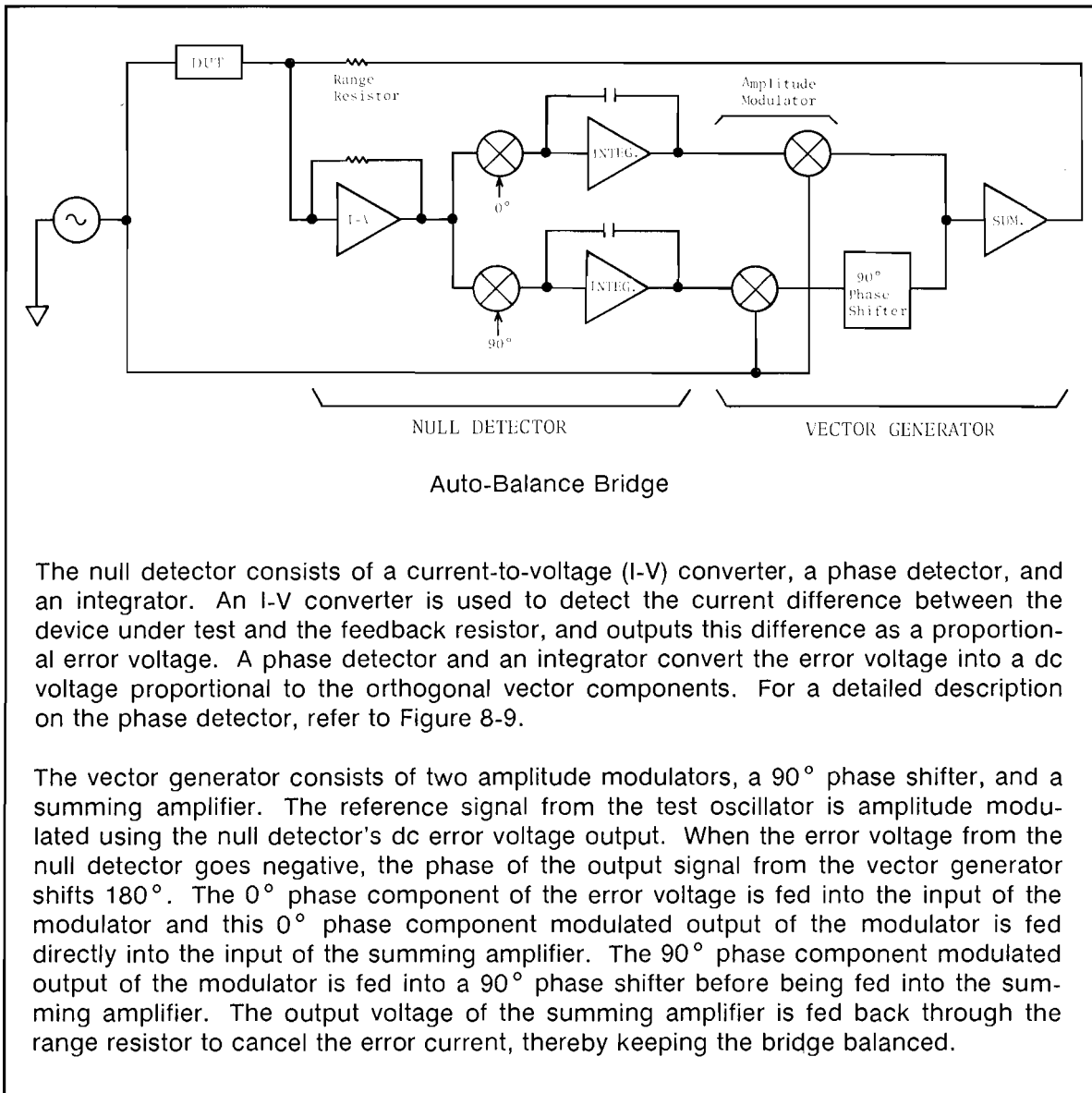

Figure 8-7. Auto-Balanced Bridge Circuit

AUTO-BALANCE BRIDGE OPERATING PRINCIPLE

The block diagram of a auto-balancing bridge circuit using a null detector, a vector generator, and a feedback resistor (range resistor) is shown below.



The null detector consists of a current-to-voltage (I-V) converter, a phase detector, and an integrator. An I-V converter is used to detect the current difference between the device under test and the feedback resistor, and outputs this difference as a proportional error voltage. A phase detector and an integrator convert the error voltage into a dc voltage proportional to the orthogonal vector components. For a detailed description on the phase detector, refer to Figure 8-9.

The vector generator consists of two amplitude modulators, a 90° phase shifter, and a summing amplifier. The reference signal from the test oscillator is amplitude modulated using the null detector's dc error voltage output. When the error voltage from the null detector goes negative, the phase of the output signal from the vector generator shifts 180°. The 0° phase component of the error voltage is fed into the input of the modulator and this 0° phase component modulated output of the modulator is fed directly into the input of the summing amplifier. The 90° phase component modulated output of the modulator is fed into a 90° phase shifter before being fed into the summing amplifier. The output voltage of the summing amplifier is fed back through the range resistor to cancel the error current, thereby keeping the bridge balanced.

Figure 8-8. Auto-Balance Bridge Operating Principle

8-18. VECTOR VOLTAGE DETECTOR

The vector voltage detector (abbreviated as VVD) detects the real and imaginary vector components of the two vector signal voltages, the test signal applied to the device under test, and the voltage across the range resistor (proportional to the current through the DUT). The VVD performs analog-to-digital (A-D) conversion of the four vector components. Figure 8-9 describes the operating principle of the vector voltage detector.

VECTOR VOLTAGE DETECTOR OPERATING PRINCIPLE

Figure A shows a simplified block diagram of the Vector Voltage Detector (VVD). The VVD consists of a phase detector and an integrator. The phase detector is a synchronous switch, controlled by the detecting pulse, whose frequency is the same as that of the signal to be detected. The detected signal is integrated, and the voltage output of the integrator is proportional to the inphase component of the input vector voltage. If the integration time is equal to the detecting pulse (reciprocal of the frequency) or to an integer multiple of the detecting pulse then,

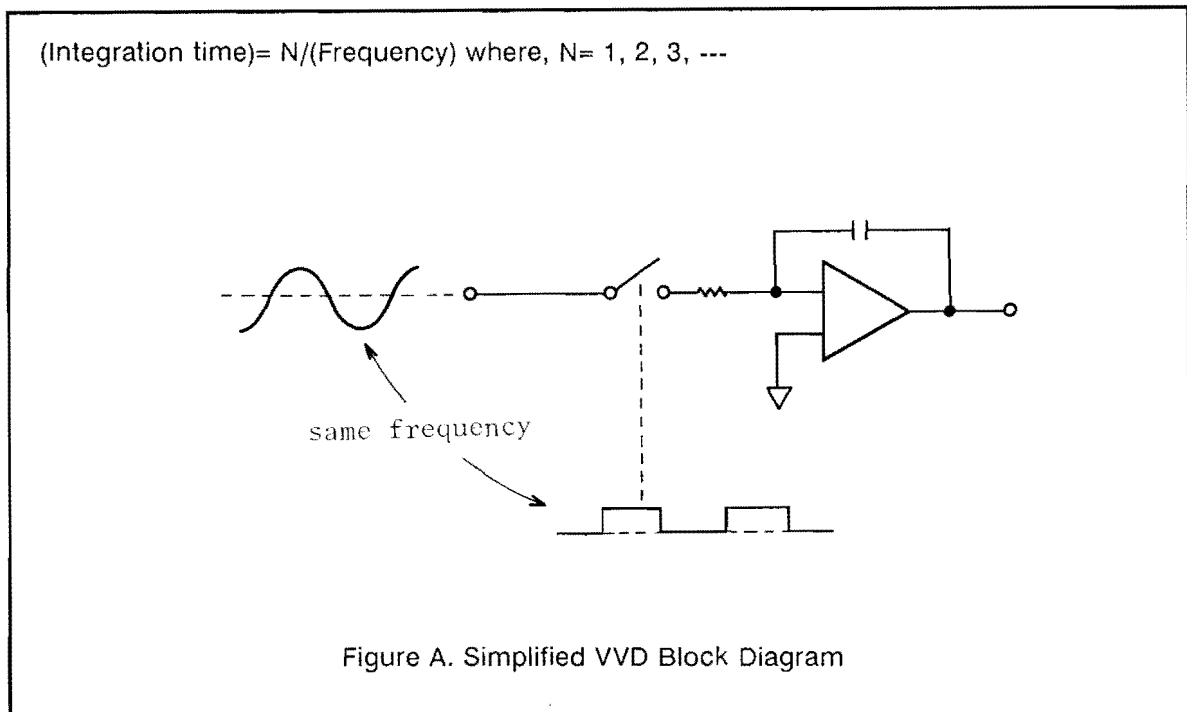

Figure 8-9. VVD Operating Principle (sheet 1 of 2)

Figure B shows the VVD waveforms when the input signal is 45° out of phase with the reference phase of the detecting pulse.

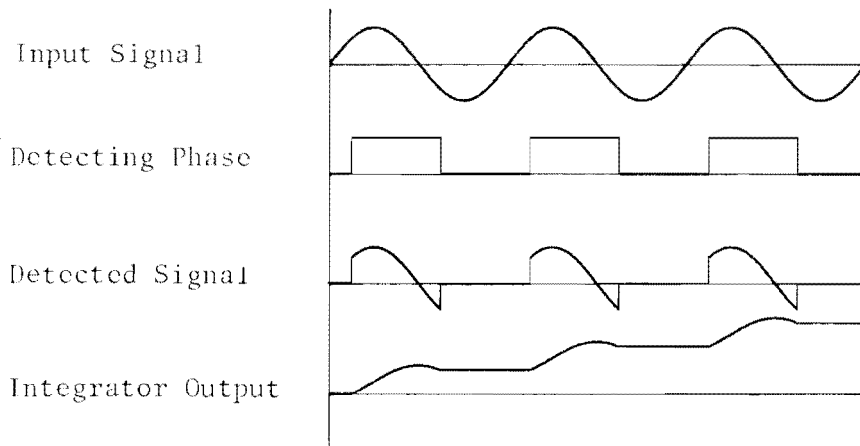

Figure B. VVD Waveforms

To digitize the integrated analog voltage, integrator capacitor is discharged at a constant rate and the time needed for the integrator's output to reach zero is measured (Dual-slope integration). If the integration time is constant, the time required to discharge the capacitor is proportional to the unknown input voltage, see Figure C.

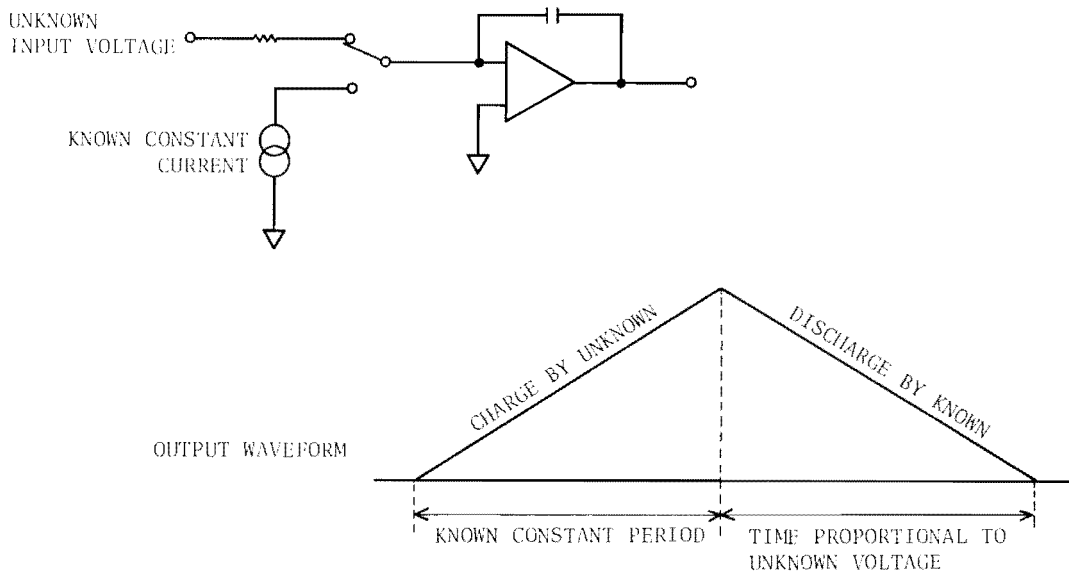

Figure C. Dual Ramp A-D Converter

Figure 8-9. Vector Voltage Detector Operating Principle (sheet 2 of 2)

8-19. VECTOR IMPEDANCE CALCULATION

Figure 8-10 shows a simplified impedance measurement circuit. e_s is the voltage applied to the device under test, e_r is the voltage across the range resistor, proportional to current flowing through the Device Under Test, and R_r is the resistance of the range resistor. e_{sx} , e_{sy} , e_{rx} and e_{ry} are the real and imaginary components of e_s and e_r , respectively. The relationship of the impedance parameters and the detected voltages-- e_{sx} , e_{sy} , e_{rx} , and e_{ry} -- is given below.

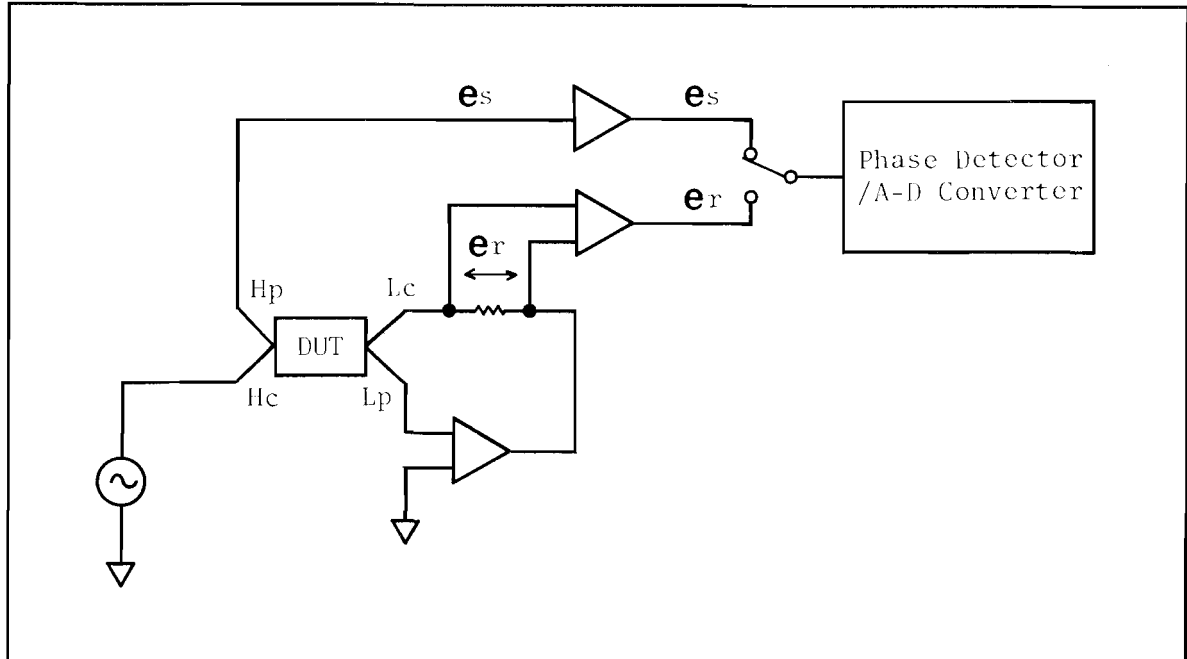

Figure 8-10. Impedance Measurement Circuit

Note

Conversion formulas for other impedance parameters are given in Section 3 of the 4194A operation manual.

8-20. GAIN-PHASE MEASUREMENT THEORY

Generally, instruments with gain-phase measurement capabilities for four-terminal network analysis are constructed using two independent voltmeter sections in order to make simultaneous measurements and a phase meter to detect the relative phase difference between the inputs. See Figure 8-11.

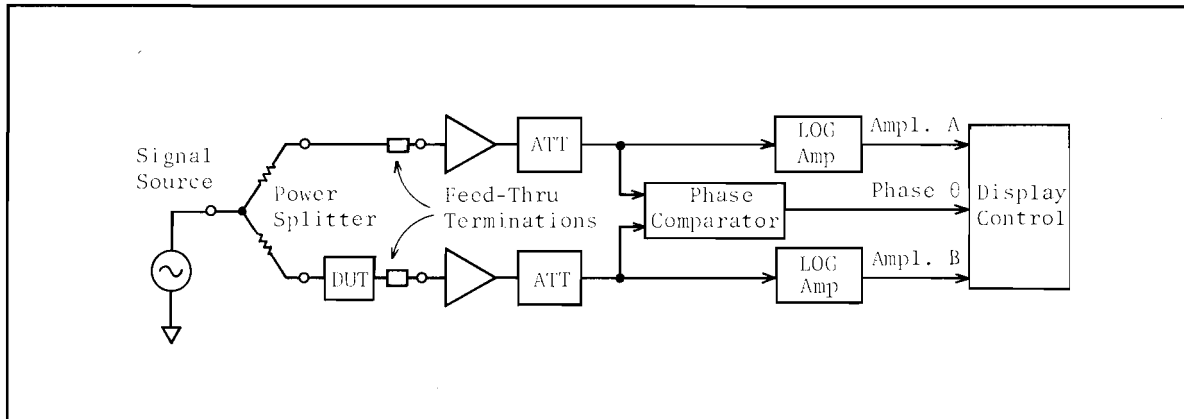

Figure 8-11. Typical Network Analyzer Construction

This configuration has a great advantage in measurement speed because both inputs are measured simultaneously. Gain-phase measurement by the 4194A is accomplished using a single channel vector voltage detector which is also used to measure the vector signals from the auto-balancing bridge circuit in the impedance measurement mode. Figure 8-12 shows the simplified block diagram of the measurement circuits related to the gain-phase measurement function.

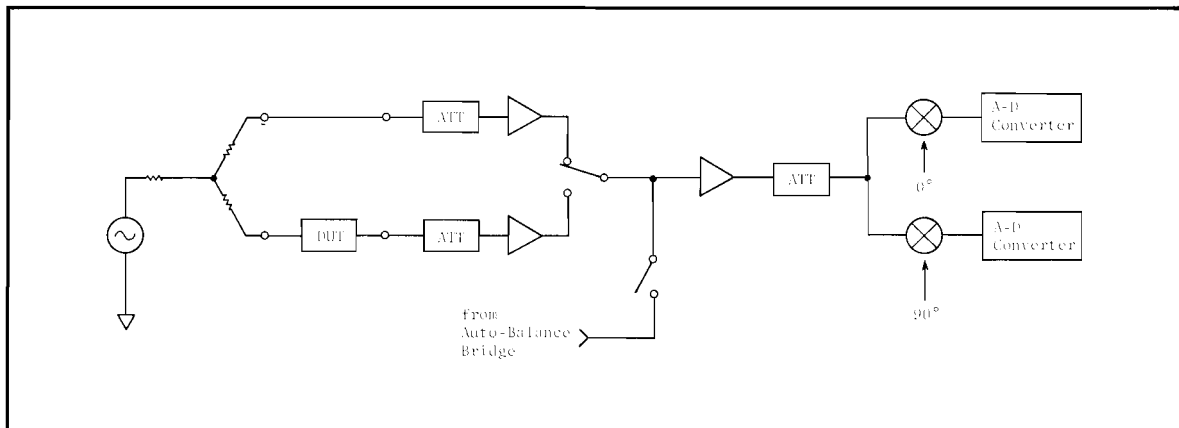

Figure 8-12. Gain-Phase Measurement Circuit Simplified Block Diagram

The signal source and the VVD section are also used in the impedance measurement mode. The Gain-phase measurement function is made possible by adding a signal output stage and two input stages to the analog circuit.

8-21. GAIN-PHASE CALCULATION

The detected vector voltage components are assigned as follows and the measurement parameters are given in the following formulas.

Vector Voltage Components

- e_{rs} : real component of reference input voltage
- e_{ry} : imaginary component of reference input voltage
- e_{tx} : real component of test input voltage
- e_{ty} : imaginary component of test input voltage

Measurement Parameters

- $e_r = e_{rx} + je_{ry}$: reference input voltage
- $e_t = e_{tx} + je_{ty}$: test input voltage

8-22. BLOCK DIAGRAM DISCUSSION

ANALOG MEASUREMENT SELECTION

A simplified block diagram of the 4194A is shown in Figure 8-13. This block diagram describes the frequency conversion process and shows the signal flow through the circuit. A detailed block diagram is shown in Figure 8-14 (foldout).

8-23. OSCILLATOR SECTION

The oscillator section consists of three oscillators, VCO, VCXO1 and VCXO2. VCO is controlled using a fractional N loop technique and oscillates 160MHz higher than the test signal (from 160.000010000MHz through 260.000000000MHz with 1mHz resolution). Refer to the A11 service sheet for a detailed description of the VCO oscillator. VCXO1, used for frequency synthesis, oscillates at a frequency of 80MHz which is then doubled to 160MHz. The output of VCXO1 is divided and used as the reference frequency for the phase detectors and the clock for the digital control section. When an appropriate external reference signal is applied to the EXT REFERENCE terminal on the control unit's rear panel, VCXO1 will synchronize to it. VCXO2 oscillates at one of two frequencies, depending on the frequency of the test signal, $(160\text{MHz} - 156.25\text{kHz})/2$ or $(160\text{MHz} - 138.8\text{kHz})/2$. VCXO2 is phase locked to VCXO1. Refer to A10's service sheet for a detailed description of VCXO1 and VCXO2.

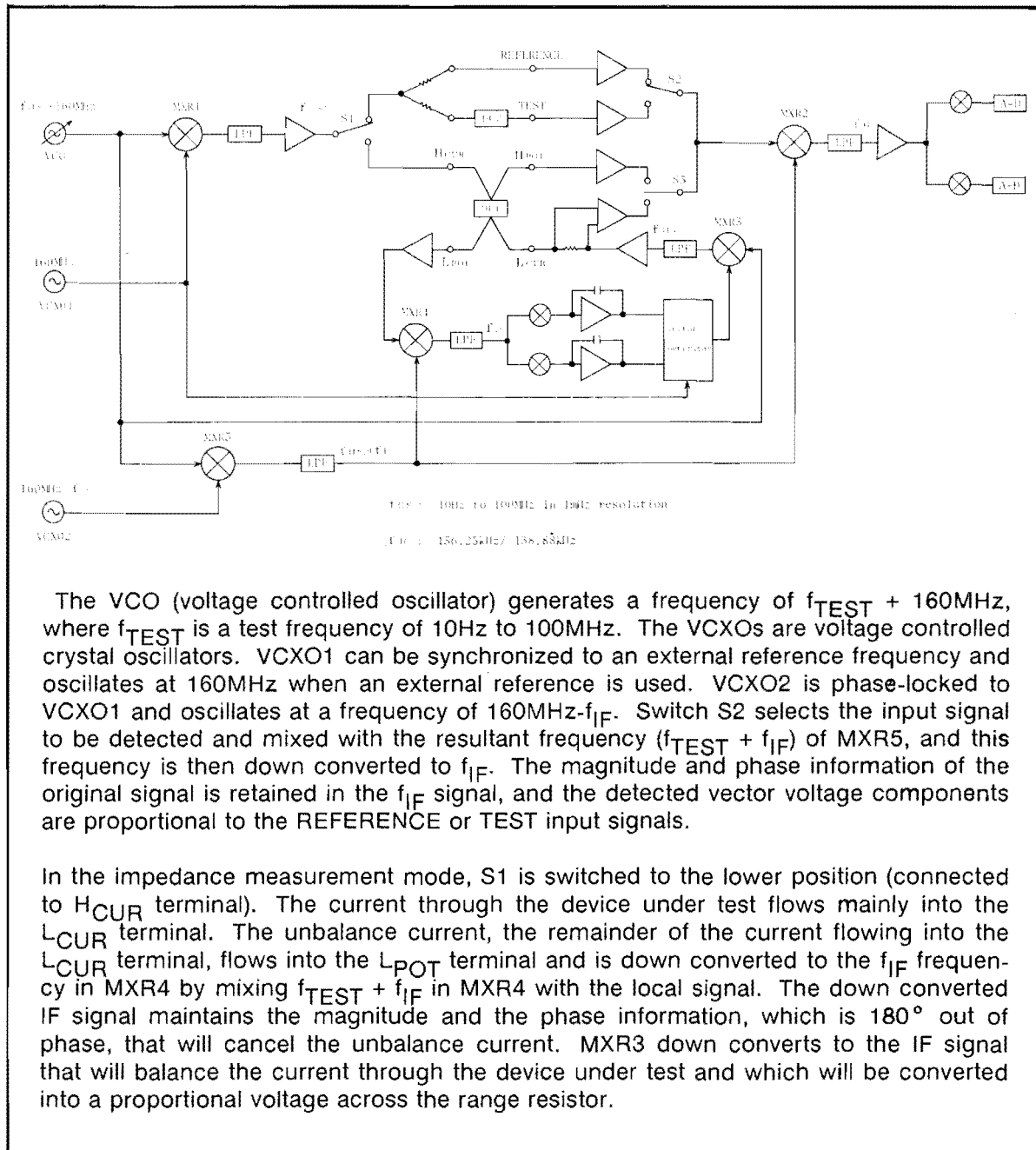

The VCO (voltage controlled oscillator) generates a frequency of $f_{TEST} + 160\text{MHz}$, where f_{TEST} is a test frequency of 10Hz to 100MHz. The VCXOs are voltage controlled crystal oscillators. VCXO1 can be synchronized to an external reference frequency and oscillates at 160MHz when an external reference is used. VCXO2 is phase-locked to VCXO1 and oscillates at a frequency of $160\text{MHz} - f_{IF}$. Switch S2 selects the input signal to be detected and mixed with the resultant frequency ($f_{TEST} + f_{IF}$) of MXR5, and this frequency is then down converted to f_{IF} . The magnitude and phase information of the original signal is retained in the f_{IF} signal, and the detected vector voltage components are proportional to the REFERENCE or TEST input signals.

In the impedance measurement mode, S1 is switched to the lower position (connected to H_{CUR} terminal). The current through the device under test flows mainly into the L_{CUR} terminal. The unbalance current, the remainder of the current flowing into the L_{CUR} terminal, flows into the L_{POT} terminal and is down converted to the f_{IF} frequency in MXR4 by mixing $f_{TEST} + f_{IF}$ in MXR4 with the local signal. The down converted IF signal maintains the magnitude and the phase information, which is 180° out of phase, that will cancel the unbalance current. MXR3 down converts to the IF signal that will balance the current through the device under test and which will be converted into a proportional voltage across the range resistor.

Figure 8-13. Simplified Block Diagram Discussion

8-24. VVD SECTION

The 4194A uses two phase detectors and two multi-slope A-D converters to simultaneously detect and measure those components of the vector voltage that are inphase and those that are 90° out of phase. See Figure 8-15. The detection phase of the phase detectors can be shifted, while maintaining a phase relationship of 90° , to reduce the measurement error caused by any unbalance existing between the two phase detectors and between the two A-D converters. Refer to A9's service sheet for a more detailed description of the Vector Voltage Detector.

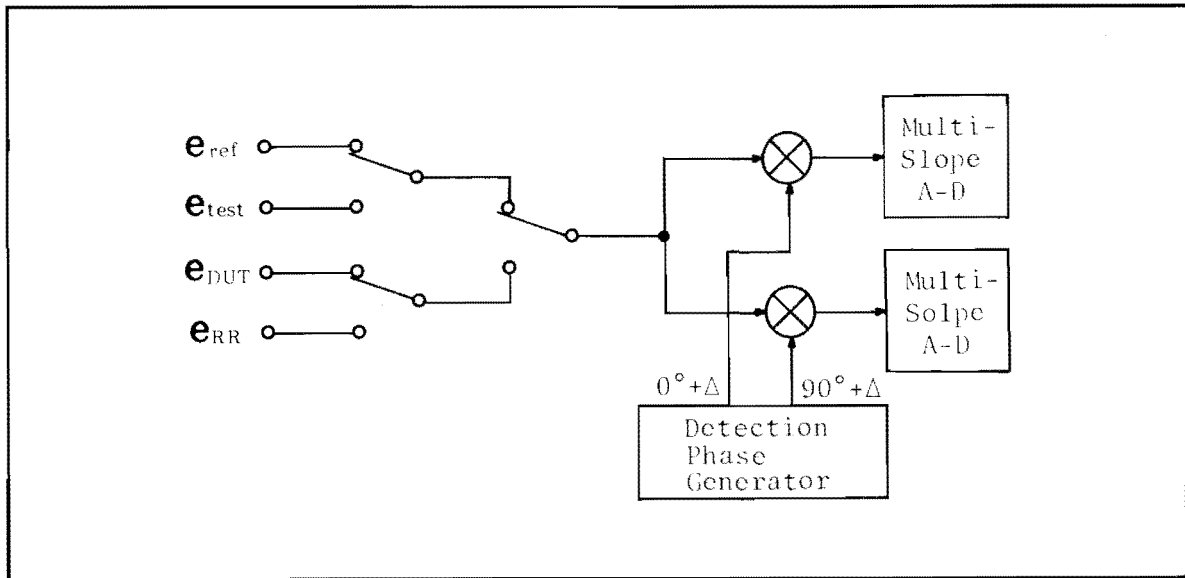

Figure 8-15. 4194A's VVD Section

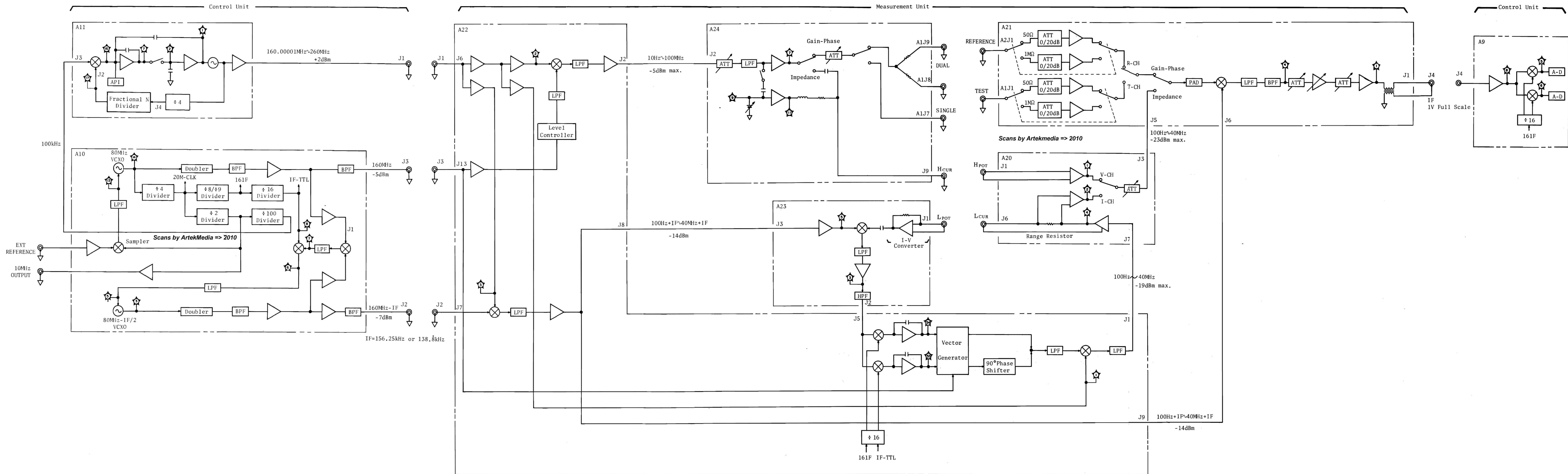

Figure 8-14. Analog Measurement Circuit Block Diagram
8-30

8-25. DIGITAL CONTROL SECTION

The 4194's digital control section is contained on three printed circuit boards -- A6, A7, and A8. The A6 board assembly contains one 16-bit CPU for data manipulation, programmed ROMs, and battery backup for continuous memory. The RAM on the A7 board can be accessed by the CPU on the A6 board and the CPU on the A8 board, the GDC (Graphic display controller) circuit, and the HP-IB interface circuit. The 16-bit CPU on the A8 board controls the measurement circuit, EEPROMs in which error calibration data for the analog measurement circuit is stored, and the measurement circuit control interfaces. Figure 8-16 shows the block diagram of the digital control section.

Note

The data manipulation CPU is designated as CPU A and the measurement control CPU is designated as CPU B. Signal names associated with a particular CPU are suffixed with A or B, respectively.

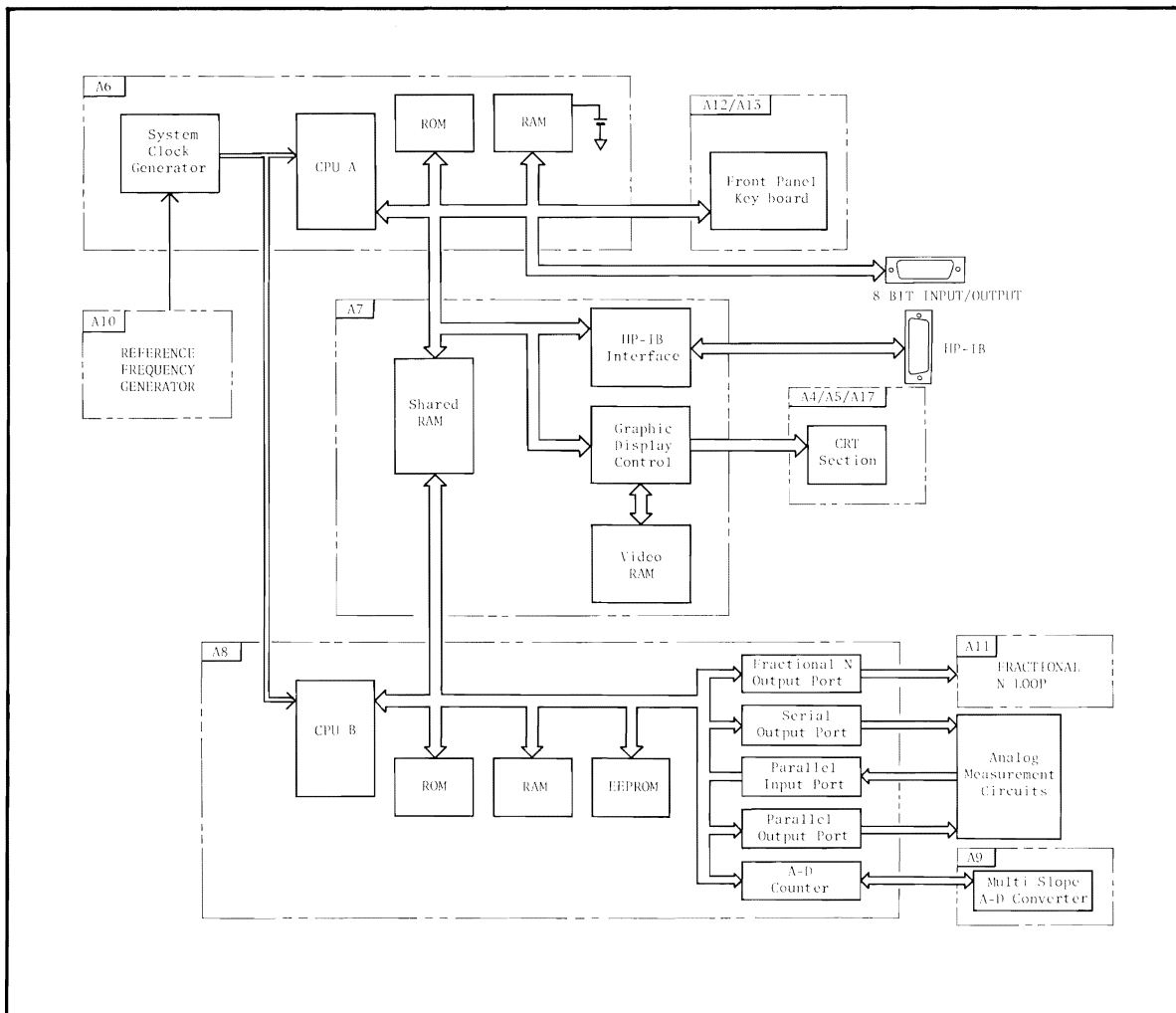

Figure 8-16. Digital Control Section Block Diagram

8-26. 4194A SELF TEST INSTRUCTIONS

The 4194A's self tests are explained in this section. Self tests are the 4194A's special functions used to update EEPROM calibration information, adjustment, troubleshooting, and ROM/RAM tests. The self test menu is listed below. Figure 8-17 explains all self tests.

8-26-1. How to RUN Self Test

1. Press the **MORE MENUS** key and the **'SELF TEST'** softkey. "STSET" will be displayed on the 4194A's keyboard input area.
2. Press **ENTER/EXECUTE** to display the self test menu.
3. Press the **'TEST No.'** softkey. "STN=" will be displayed on the 4194A's keyboard input area.
4. Enter the desired test number and press **ENTER/EXECUTE**.

8-26-2. Self Test Softkey Meanings

'TEST No.'	This Self Test Menu screen softkey is used to select a self test. Press this softkey, to display "STN=" on the keyboard input line.
'TEST END'	This softkey is used to exit from the self test mode and reset the 4194A to its initial turn on settings. This key is enabled while a test is in progress.
'START'	This softkey is used to start the selected test.
'STOP'	This softkey is used to stop the test in progress.
'TEST MENUS'	This softkey is displayed on selected test screens, and is valid only when a test is not in progress.

Table 8-3. 4194A's Self Test Menus

No.	SELF TEST MENUS
10:	A/D ADJUST; 0° ch-90° ch Tracking
11:	A/D TEST 1; Raw data in Normal mode
12:	A/D TEST 2; Raw data in Average mode
20:	VCO TEST; Frequency Range
30:	EEPROM; GAIN ERR CORRECT; Rch 50/75Ω 0dB
31:	EEPROM; GAIN ERR CORRECT; Rch 50/75Ω 20dB
32:	EEPROM; GAIN ERR CORRECT; Rch 1MΩ 0dB
33:	EEPROM; GAIN ERR CORRECT; Rch 1MΩ 20dB
34:	EEPROM; GAIN ERR CORRECT; Tch 50/75Ω 0dB
35:	EEPROM; GAIN ERR CORRECT; Tch 50/75Ω 20dB
36:	EEPROM; GAIN ERR CORRECT; Tch 1MΩ 0dB
37:	EEPROM; GAIN ERR CORRECT; Tch 1MΩ 20dB
38:	THEORETICAL DEFAULT VALUE SET FOR CAL
40:	GAIN-PHASE TEST; IF Gain Adjustment
50:	EEPROM; PHASE TRACK DATA WRITE; Cable 0m
51:	EEPROM; PHASE TRACK DATA WRITE; Cable 1m
52:	PHASE TRACK TEST
60:	EEPROM; Z_θ ERR CORRECT; 0m 50Ω
61:	EEPROM; Z_θ ERR CORRECT; 0m 400Ω
62:	EEPROM; Z_θ ERR CORRECT; 0m 3.2kΩ
63:	EEPROM; Z_θ ERR CORRECT; 0m 25.6kΩ
64:	EEPROM; Z_θ ERR CORRECT; 1m 50Ω
65:	EEPROM; Z_θ ERR CORRECT; 1m 400Ω
66:	EEPROM; Z_θ ERR CORRECT; 1m 3.2kΩ
67:	EEPROM; Z_θ ERR CORRECT; 1m 25.6kΩ
71:	OSC LEVEL GAIN ADJUST
72:	EEPROM; OSC LEVEL LINEARITY CORRECTION
73:	EEPROM; Z_θ V MONITOR ERR CORRECT; 0m
74:	EEPROM; Z_θ V MONITOR ERR CORRECT; 1m
80:	CRT TEST 1; Corner Distortion
81:	CRT TEST 2; Linearity
82:	CRT TEST 3; Resolution
83:	CRT TEST 4; Convergence & Focus
84:	CRT TEST 5; High-Voltage Regulation
85:	CRT TEST 6; Uniformity
86:	CRT TEST 7; White Balance
87:	CRT TEST 8; Video Amplifier
90:	V SYNC. Adjustment
91:	H SYNC. Adjustment
100:	DRAM TEST 1; CPU A Read/Write
101:	DRAM TEST 2; CPU B Read/Write
102:	SRAM TEST 1; CPU A Read/Write
103:	SRAM TEST 2; CPU B Read/Write
104:	VRAM TEST; CPU A Read/Write
105:	EEPROM TEST 1; CPU B Read
106:	EEPROM TEST 2; CPU B Write (Erase)
110:	COLOR TABLE TEST
120:	KEY & RPG TEST
121:	LED TEST
130:	ROM CHECK SUM LIST

Self Test #10 Phase Detector/A-D Converter Tracking Adjustment

This self test is used to minimize the gain and phase tracking errors of the REFERENCE and TEST CHANNEL phase detectors, and the A-D converters. Because the input signal for the two INPUT CHANNEL phase detectors and the A-D converters comes from the test oscillator on the A9 board, other measurement circuits will not affect this test, and this test will not be affected by the condition of other analog circuits.

Amplitude, gain error, and phase error are displayed. Displayed values are scrolled up on the screen, so when making an adjustment, watch only the lowest displayed line.

The typical value range of amplitude is $3.500000E+05 \pm 20\%$ (IF is 156.25kHz), or $2.800000E+05 \pm 20\%$ (IF is 138.89kHz).

The gain and phase values should be adjusted within the limits specified. See Paragraph 5-19 for the limit values.

INTEG TIME is set to **SHORT**. The IF frequency and integration time are determined by the **SPOT FREQ** setting.

Self Test #11 Phase Detector/A-D Converter Test (NORMAL mode)

This self test is used to troubleshoot the phase detectors and the A-D converters. Because the input signal for the two channel phase detectors and the A-D converters come from the test oscillator on the A9 board, you can observe the A-D converters' waveform in normal mode (**AVERAGING TIME** is 1) isolated from the other measurement circuits.

Auto zero measurement values, first converted values, and second converted values for both the 0° and 90° channel are displayed. The Auto zero measurement value is subtracted from the converted measurement values. The displayed values show the variation for troubleshooting.

The **SPOT FREQ** setting determines integration time and IF frequency (of two possible frequencies). You can also set **INTEG TIME** to **SHORT**, **MED**, or **LONG** using the **INTEG TIME** key.

Self Test #12 Phase Detector/A-D Converter Test (AVERAGING mode)

Use this self test to troubleshoot the phase detectors and A-D converters and to observe the A-D converters' waveforms while in the averaging mode (**AVERAGING** >2), isolating the convertors from other measurement circuits.

AVERAGING TIME is set using the **AVERAGING** key, and the **SPOT FREQ** setting determines integration time and IF frequency (of two possible frequencies). You can also set **INTEG TIME** to **SHORT**, **MED**, or **LONG** using the **INTEG TIME** key.

Figure 8-17. Self Test Instructions (sheet 1 of 15)

Under ideal conditions the relationship between the displayed values will be as shown below. The tolerances between ideal values and actual values cannot be given exactly, but this information will be helpful when troubleshooting the reference detection phase generator.

Phase	AD_0	AD_90
0	(a)	(b)
π	(-a)	(-b)
$(1/2)\pi$	(b)	(-a)
$(3/2)\pi$	(-b)	(a)
$(1/4)\pi$	(c)	(d)
$(5/4)\pi$	(-c)	(-d)
$(3/4)\pi$	(d)	(-c)
$(7/4)\pi$	(-d)	(c)
$(1/8)\pi$	(e)	(f)
$(9/8)\pi$	(-e)	(-f)
$(5/8)\pi$	(f)	(-e)
$(13/8)\pi$	(-f)	(e)
$(3/8)\pi$	(g)	(h)
$(11/8)\pi$	(-g)	(-h)
$(7/8)\pi$	(h)	(-g)
$(15/8)\pi$	(-h)	(g)

Self Test #20 VCO Test

This self test is used to troubleshoot the A11 Fractional N Loop board. The VCO frequency can be set using the **SPOT FREQ** key. The VCO frequency is 160MHz higher than the SPOT FREQ setting. In this test, the range over which the SPOT FREQ parameter can be used to offset the nominal 160MHz VCO frequency is -20MHz to +150MHz. For example when the SPOT FREQ is set to -20MHz the VCO frequency will be 140MHz, and when the SPOT FREQ is set to 160MHz the VCO frequency will be 310MHz.

The VCO frequency, and the lock/unlock status of the VCO (+ : too high, - : too low) are displayed. When the VCO is locked, the lock/unlock polarity has no meaning. Note that the lock/unlock indication does not respond quickly. If you change the **SPOT FREQ** setting, wait approximately 5 seconds to verify whether the VCO is locked or not. If you want quicker response, use an oscilloscope to observe the levels at A11U35-3 and A11U35-6, rather than looking at the 4194A's displayed messages.

Figure 8-17. Self Test Instructions (Sheet 2 of 15)

Self Test #30 through #37

Amplitude Measurement Calibration

These eight tests are used to update amplitude measurement EEPROM calibration data. Each tests correlates the amplitude measurement of the REFERENCE/TEST channel, 50(75) Ω /1M Ω IMPEDANCE, with the 0dB/20dB ATTENUATION settings. In these test modes, the 4194A measures the amplitude without using the compensation data in EEPROM.

To perform these tests, an RF voltmeter, accurate over the frequency range of 10Hz to 100MHz, is necessary to compare the 4194A's uncorrected measurement values. The equipment setup for these tests is shown below. An internal or external power splitter can be used.

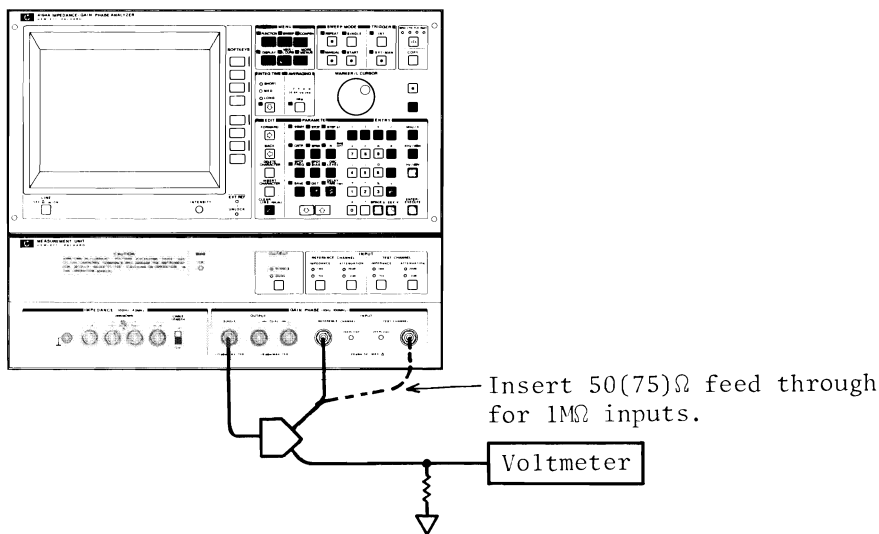

When one of these self tests is started, a single sweep measurement will be performed at 50 preset frequency points, and uncorrected amplitude measurement values (raw data) will be displayed on the CRT. These measured values can be read while in the HP-IB mode using the "A?" or "B?" commands. The compensation factor to be stored in EEPROM can be derived by comparing the raw data and the voltmeter readings. The calculated compensation factors for 50 preset frequency points should be stored in the C register using the "C(n)=" command, where n is 1, 2, 3, . . . 50, corresponding to the preset measurement point. The "EP" command transfers the contents of the C register to the EEPROM. The basic equation used to derive the compensation factor is as follows.

$$[\text{Compensation Factor}] = (V_{\text{ref}} / V_{\text{meas}})^2$$

Where V_{ref} is the voltmeter reading, and V_{meas} is the 4194A's raw data. Actually, the V_{ref} value should be compensated for because the power splitter and cables used to connect the equipment will cause tracking errors, etc. The compensation factor must be between 0.5 and 2.0, otherwise the 4194A must be repaired.

Figure 8-17. Self Test Instructions (Sheet 3 of 15)

In these test modes, the 4194A's measurement circuits are set as follows.

FUNCTION	Gain-Phase
INTEG TIME	MED
AVERAGING	16
OSC Level	-1dBm

The 50 Preset measurement frequency points are listed below. Units are in Hertz (Hz).

10	100	1k	10k	100k	1M	10M	100M
15	200	2k	15k	200k	2M	15M	
20	300	3k	20k	300k	3M	20M	
25	500	5k	25k	500k	5M	30M	
30	700	7k	(30k-1m)	700k	7M	40M	
40			30k			50M	
50			40k			60M	
60			50k			70M	
80			60k			80M	
			80k			90M	

Before performing these tests, set A8W2 to its lower-most position to write enable the EEPROM. Calibration procedures are given in the 16349A's Operation Note.

Self Test #38 Calibration Reference Value Registration

This self test is used to enter the calibration standard's reference calibration values into the EEPROM. The values set at the factory (for the HP 41941A/B impedance probe), are listed below.

(1) for FNC1

$$0S = 0.00000 \quad S + 0.00000 \quad F$$

$$0\Omega = 0.00000 \quad \Omega + 0.00000 \quad H$$

$$STD = 50.0000 \quad \Omega + 0.00000 \quad H$$

(2) for FNC3

$$0S = 0.00000 \quad S + 310.000 \quad fF$$

$$0\Omega = 0.00000 \quad \Omega + 0.00000 \quad H$$

$$STD = 50.0000 \quad \Omega + 5.75000 \quad nH$$

Before performing these tests, set A8W2 to its lower-most position to write enable the EEPROM. For more information, refer to Appendix F of the 4194A Operation Manual.

Figure 8-17. Self Test Instructions (Sheet 4 of 15)

Self Test #40 IF Attenuator Adjustment

This self test is used to adjust the attenuation and phase shift of the IF attenuator on the A21 board. The analog measurement circuits are set as follows.

FUNCTION	GAIN-PHASE, dB- θ
Frequency	1MHz
INTEG TIME	MED
AVERAGING	16
OSC Level	-25dBm
OUTPUT	SINGLE
INPUT IMPEDANCE	50 Ω
INPUT ATTENUATION	0dB

The displayed GAIN and PHASE values should be adjusted so they are within the adjustment limits listed in Paragraph 5-18-5.

Self Test #50 and #51 Phase Track Data Calibration

These tests are used to automatically determine the Phase Track data for each preset frequency point, and then to write the Phase Track data into EEPROM. Self test #50 is for 0m CABLE LENGTH and #51 is for the 1m CABLE LENGTH. The Analog measurement circuits are set as follows.

FUNCTION	IMPEDANCE
OSC Level	1Vrms
Frequency	preset 56 frequency points

Before performing these tests, set A8W2 to its lower-most position to write enable the EEPROM. For the actual procedures, refer to Paragraph 5-20-1.

Self Test #52 Bridge Phase Track Test

This test is used to troubleshoot the auto-balance-bridge circuit. The test frequency can be changed using the **SPOT FREQ** key and the test signal level can be changed using the **OSC LEVEL** key. Phase track data (0 through 15) can be entered with the '**PHASE=**' softkey and the range resistor is selected with the '**Z RNG=**' softkey. The Phase track data parameter is used to shift the phase of the auto-balance-bridge loop in steps of 22.5°.

Figure 8-17. Self Test Instructions (Sheet 5 of 15)

Self Test #60 through #67**Impedance Measurement Calibration**

These tests are used to obtain Impedance Measurement calibration data and to store the data in EEPROM. This calibration data is used to compensate the phase shift error of the Range Resistor. To perform these tests, calibrated 50Ω, 400Ω, 3.2kΩ, and 25.6kΩ standard resistors are required and are supplied as a part of the HP 16349A. The equation used to derive the compensation factor is shown below.

$$Rerr = Rr \times (Rc \times Rm - Xc \times Xm) / ((Rm^2) + (Xm^2))$$

$$Xerr = Rr \times (Xc \times Rm - Rc \times Xm) / ((Rm^2) + (Xm^2))$$

Where Rr is the range resistor value (50Ω, 400Ω, 3.2kΩ, or 25.6kΩ) and Rc and Xc are the standards' resistance and reactance values at the frequency of calibration. Rm and Xm are the raw measurement resistance and reactance values.

The calculated compensation factors at the preset frequency points should be stored in the C register using the "C(n)=" command, where n is an integer number that corresponds to the preset measurement point. The "EP" command transfers the contents of the C register into EEPROM. The calibration frequencies for each range are listed below. The frequencies are given in Hertz (Hz).

For the 50, and 400, Ranges (Self test #60, 61, 64, and 65)

100	1k	10k	100k	1M	10M	20M	30M	40M
200	2k	(30k-1m)	500k	2M	11M	21M	31M	
300	5k	30k		4M	12M	22M	32M	
400		50k		6M	13M	23M	33M	
500				8M	14M	24M	34M	
					15M	25M	35M	
					16M	26M	36M	
					17M	27M	37M	
					18M	28M	38M	
					19M	29M	39M	

For the 3.2k, Range (Self test #62 and 66)

100	1k	10k	100k	1M	6M
150	1.5k	20k	150k	1.5M	6.5M
200	2k	(30k-1m)	200k	2M	7M
300	5k	30k	300k	2.5M	7.5M
400	7k	50k	400k	3M	8M
500		70k	500k	3.5M	8.5M
700			600k	4M	9M
			700k	4.5M	9.5M
			800k	5M	10M
			900k	5.5M	

Figure 8-17. Self Test Instructions (Sheet 6 of 15)

For 25.6k, Range (Self test #63 and 67)

100	1k	10k	100k	600k
150	2k	15k	150k	650k
200	5k	20k	200k	700k
300	7k	(30k-1m)	250k	750k
400		30k	300k	800k
500		40k	350k	850k
700		50k	400k	900k
		60k	450k	950k
		70k	500k	1M
		80k	550k	
		90k		

Before performing these tests, set A8W2 to its lower-most position to write enable the EEPROM. Refer to the 16349A's Operation Note for calibration procedures.

Self Test #71 OSC Level Full Scale Adjustment

This test is used for full scale OSC level adjustment. The 4194A is set up as follows.

FUNCTION	Gain-Phase
OUTPUT	SINGLE
Test Frequency	100kHz
OSC level related attenuators	all 0dB
Level vernier control	Full Scale

The adjustment procedures are given in Paragraph 5-15-3.

Figure 8-17. Self Test Instructions (Sheet 7 of 15)

Selftest #72 OSC Level Linearity Calibration

This test is used for EEPROM calibration of OSC level linearity. To perform this test, connect the SINGLE OUTPUT to the REFERENCE CHANNEL INPUT with a BNC cable. This test performs a special kind of OSC level sweep measurement. Only the linearity of the REFERENCE channel amplitude measurement is necessary: the absolute amplitude accuracy is not important for this test. There are 256 OSC level control values for the Vernier Level circuit's D-A converter, and they are listed in hexadecimal as follows.

002	004	006	008	00A	00C	00E	010
012	014	016	018	01A	01C	01E	020
022	024	026	028	02A	02C	02E	030
032	034	036	038	03A	03C	03E	040
042	044	046	048	04A	04C	04E	050
052	054	056	058	05A	05C	05E	060
062	064	066	068	06A	06C	06E	070
072	074	076	078	07A	07C	07E	080
084	088	08C	090	094	098	09C	0A0
0A4	0A8	0AC	0B0	0B4	0B8	0BC	0C0
0C4	0C8	0CC	0D0	0D4	0D8	0DC	0E0
0E4	0E8	0EC	0F0	0F4	0F8	0FC	100
108	110	118	120	128	130	138	140
148	150	158	160	168	170	178	180
188	190	198	1A0	1A8	1B0	1B8	1C0
1C8	1D0	1D8	1E0	1E8	1F0	1F8	200
210	220	230	240	250	260	270	280
290	2A0	2B0	2C0	2D0	2E0	2F0	300
310	320	330	340	350	360	370	380
390	3A0	3B0	3C0	3D0	3E0	3F0	400
420	440	460	480	4A0	4C0	4E0	500
520	540	560	580	5A0	5C0	5E0	600
620	640	660	680	6A0	6C0	6E0	700
720	740	760	780	7A0	7C0	7E0	800
820	840	860	880	8A0	8C0	8E0	900
920	940	960	980	9A0	9C0	9E0	A00
A20	A40	A60	A80	AA0	AC0	AE0	B00
B20	B40	B60	B80	BA0	BC0	BE0	C00
C20	C40	C60	C80	CA0	CC0	CE0	D00
D20	D40	D60	D80	DA0	DC0	DE0	E00
E20	E40	E60	E80	EA0	EC0	EE0	F00
F20	F40	F60	F80	FA0	FC0	FE0	FFF

The compensation factors are derived as follows.

1. Normalize the 4194A's REFERENCE channel measurement value using the following equation, where i is an integer up to 256, and $A(i)$ is the measurement REFERENCE channel amplitude at i .

$$Y(i) = 4095 \times A(i)/A(256)$$

Figure 8-17. Self Test Instructions (Sheet 8 of 15)

2. Determine the value of k_i which satisfies the following equation, where $X(i)$ is a decimal value, given in hexadecimal form in the preceding table, of the data input to the D-A converter.

$$Y(k_i) < X(i) \leq Y(k_i+1)$$

3. Calculate $x(i)$ as follows.

$$X(i) = X(k_i) \cdot (Y(k_i + 1) - X(i)) + X(k_i + 1) \cdot (X(i) - Y(k_i)) \\ Y(k_i + 1) - Y(k_i)$$

4. Calculate $C(i)$ as follows and enter the value into the 4194A's C register.

$$C(i) = X(i) - x(i)$$

5. Send an "EP" command to the 4194A to transfer the data stored in the C register into the EEPROM.

In this test the 4194A is set as follows.

FUNCTION	Gain-Phase (R-ch amplitude)
OUTPUT	SINGLE
Test Frequency	100kHz

Before performing these tests, set A8W2 to its lower-most position to write enable the EEPROM. For the actual calibration procedures, refer to the 16349A's Operation Note.

Figure 8-17. Self Test Instructions (Sheet 9 of 15)

Self Test #73 and #74**OSC Level Monitor Calibration**

This test is used for EEPROM calibration of the test signal monitor level error.

To perform these tests, an accurate RF voltmeter that covers the frequency range of 10Hz to 40MHz is necessary for comparing the measured voltage with the 4194A's uncorrected voltage monitor measurement. The equipment setup for these tests is shown below.

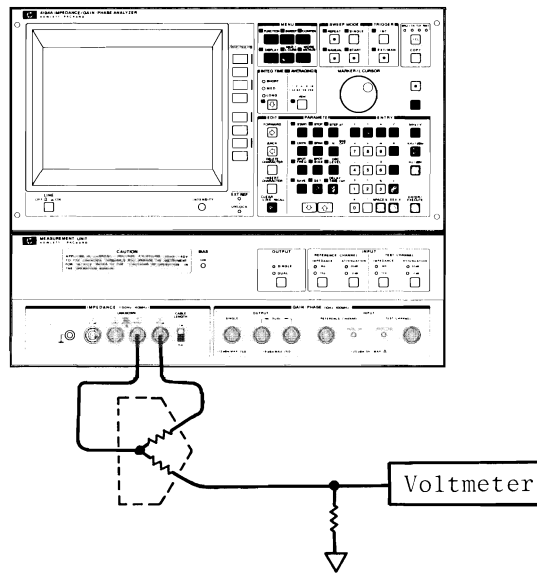

The calibration frequency points are identical to those of Impedance measurement calibration of self tests #60 through #67.

$$[V \text{ Monitor Compensation Factor}] = (2 \times V_{\text{ref}} / V_{\text{mon}})^2$$

Where V_{ref} is the voltmeter reading and V_{mon} is the raw data from the 4194A's voltage monitor. The value of V_{ref} should be compensated for because the power splitter and cables used to interconnect the equipment will cause tracking errors. The compensation factor must be between 6.0 and 0.1, otherwise the 4194A must be repaired.

$$[I \text{ Monitor Compensation Factor}] = V_{\text{coef}} / (R_{\text{err}}^2 + X_{\text{err}}^2)$$

Where V_{coef} is the Voltage Monitor Compensation Factor, and R_{err} and X_{err} are the Impedance Measurement compensation factors.

Calculate the V/I monitor compensation factors at the calibration frequency points and store the V and I monitor compensation factors into the 4194A's C and D registers, respectively. Then send an "EP" command to the 4194A.

Before performing these tests, set A8W2 to its lower-most position to write enable the EEPROM. See the 16349A's Operation Note for calibration procedures.

Figure 8-17. Self Test Instructions (Sheet 10 of 15)

Self Test #80 Corner Distortion Test

This test is used to troubleshoot the CRT display by displaying three different rectangular scales. To abort this test, press the second softkey.

Self Test #81 Display Linearity Test

This test is used to adjust and troubleshoot the CRT display by displaying an 8 by 6 graticule. To abort this test, press the second softkey. The adjustment procedure is given in Paragraph 5-21-5.

Self Test #82 Display Resolution Test

This test displays a special test pattern to use for troubleshoot the CRT display. The color of the pattern can be changed by pressing the **EDIT up/down** key. To abort this test, press the second softkey.

Self Test #83 Convergence and Focus Test

This test is used to adjust and troubleshoot the CRT display by displaying 17 by 13 dot pattern. The color of the dots can be changed by pressing the **EDIT up/down** key. To abort this test, press the second softkey. For the actual adjustment procedure, refer to Paragraph 5-21-6.

Self Test #84 High Voltage Regulation Test

This test is used to troubleshoot the CRT display by displaying a special test pattern which is similar to that used in self test #81. The white band will be slightly distorted because the 4194A's voltage regulator cannot supply enough current. To halt this test, press the second softkey.

Self Test #85 Uniformity Test

This test is used to troubleshoot the CRT circuits by displaying a solid white screen. Press the **EDIT up/down** key to change the color of the display. To halt this test, press the second softkey.

Self Test #86 White Balance Test

This test is used to adjust and troubleshoot the CRT display. Four areas of different intensity will be displayed. To halt this test, press the second softkey. For the actual adjustment procedures, refer to Paragraph 5-21-6.

Figure 8-17. Self Test Instructions (Sheet 11 of 15)

Self Test #87 Video Amplifier Test

This test is used to troubleshoot the CRT display. Four brightness bands--red, blue, green, and white--will be displayed. To abort this test, press the second softkey.

Self Test #90 Vertical Hold Adjustment

This test is used to adjust and troubleshoot the CRT display driver. Two vertical sync. frequencies are repeatedly generated. For the actual adjustment procedure, refer to Paragraph 5-21-4. To halt this test, press the second softkey.

Self Test #91 Horizontal Hold Adjustment

This test is used to adjust and troubleshoot the CRT display driver. Two horizontal sync. frequencies are repeatedly generated. For the actual adjustment procedure, refer to Paragraph 5-21-4. To abort this test, press the second softkey.

Self Test #100 through #103 RAM Read/Write Tests

CPU A (CPU on the A6 board) or CPU B (CPU on the A8 board) performs a read/write test for the dynamic RAMs on the A7 board or the static RAMs on the A6 or A8 board, respectively. An example error message is "R/W error, address=nnnnnnH", where nnnnnnH is the address in hex where the read/write error occurred. This test executes repeatedly until the 'STOP' or 'TEST END' softkey is pressed.

Note

Self test #102 erases all ASPs, Program Point Tables, SAVED settings, HP-IB address, etc. stored in the CMOS continuous memory.

Self Test #104 Video RAM Read/Write Test

This test is used to test VRAMs (video RAMs) and is performed automatically (no adjustments to be made).

Self Test #105 EEPROM Read Test

This test performs an EEPROM read test.

Figure 8-17. Self Test Instructions (Sheet 12 of 15)

Self Test #106 EEPROM Write/Erase Test

This test performs an EEPROM write/erase test. To perform this test, set A8W2 to its lower-most position.

CAUTION

THIS TEST ERASES ALL EEPROM DATA. IF YOU DON'T INTEND TO PERFORM EEPROM CALIBRATION, DO NOT PERFORM THIS TEST. AN HP 16349A IS REQUIRED TO PERFORM EEPROM CALIBRATION.

Self Test #110 COLOR TABLE TEST

For design use only.

Self Test #120 KEY & RPG TEST

This test is used to test the front panel key switches. The key numbers are shown on the following page. When the Blue key is on, add 100 to the key number. When the Green key is pressed followed by any key, add 200 to the key number.

Figure 8-17. Self Test Instructions (Sheet 13 of 15)

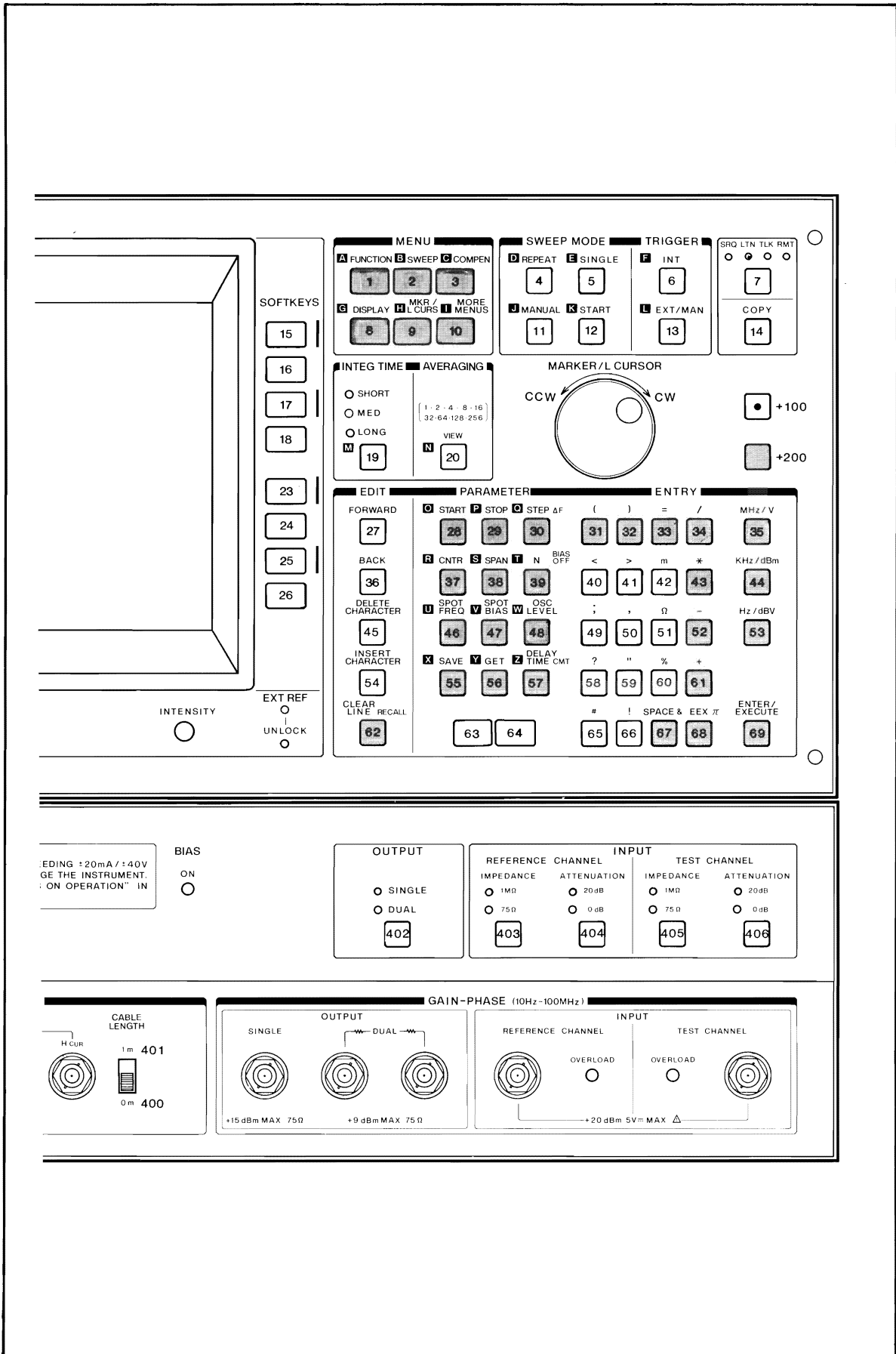

Figure 8-17. Self Test Instructions (Sheet 14 of 15)

Self Test #121 LED TEST

All LED indicators on the front panels, except for the EXT REF indicator, will blink. The LEDs on the front panel of the control unit will blink at approximately 1Hz. The LEDs on the front panel of the measurement unit panel will blink in the following manner.

1. All LEDs will turn on.
2. The DUAL, 50 Ω , and 0dB indicators will turn on.
3. The SINGLE, 1M Ω , and 20dB indicators will turn on.
4. Repeat, starting from step 1.

Self Test #130 ROM CHECK SUM LIST

For design use only.

Figure 8-17. Self Test Instructions (Sheet 15 of 15)

8-27. POWER-ON SELF TEST

The 4194A performs a power-on self test and ROM/RAM tests every time it is turned on. If an error is detected and, an error message will be displayed in the system message area of the display. The A6 and A8 boards have LED indicator arrays which indicate the self test status and results. Figure 8-18 shows some example error messages and their meanings. Figure 8-19 shows some example LED indicator patterns and their meanings.

A: ROM check sum err, nnn

An A6 board ROM check sum error was detected, where nnn is a three digit decimal number that indicates the number of the ROM in which had an error occurred. Table A (below) lists the relationship between ROM numbers and reference designators. If the message shown above is displayed, troubleshoot the A6 board using signature analysis. When using signature analysis, refer to the 16349A's Operation Note.

Table A. A6 ROM number and Reference Designators

Reference Designator	ROM Number	Reference Designator	ROM Number
A6U4	001	A6U20	002
A6U5	003	A6U21	004
A6U6	005	A6U22	006
A6U7	007	A6U23	008
A6U8	009	A6U24	010
A6U9	011	A6U25	012
A6U10	013	A6U26	014
A6U11	015	A6U27	016
A6U12	017	A6U28	018

Figure 8-18. Power-On Self Test Error Messages (Sheet 1 of 2)

B: ROM check sum err, nnn

A ROM check sum error was detected on the A8 board, where nnn is a three digit decimal number that identifies the ROM in which the error was detected. Table B (below) lists the relationship between ROM numbers and reference designators. If the message shown above is displayed, troubleshoot the A8 board using signature analysis. For signature analysis information, refer to the 16349A's Operation Note.

Table B. A8 ROM Number and Reference Designators

Reference Designator	ROM Number	Reference Designator	ROM Number
A8U1	001	A8U2	002
A8U3	003	A8U4	004
A8U5	005	A8U6	006
A8U7	007	A8U8	008
A8U9	009	A8U10	010

CPUA RAM R/W error, nnnnnnH

A read/write test error was detected (on the A6 board) during the execution of a read/write test by CPU A on the A7 board's shared Dynamic RAM, where nnnnnnH is the address in hexadecimal where the read/write error occurred. If this message is displayed, troubleshoot the A6 or A7 board using signature analysis. For signature analysis information, refer to the 16349A's Operation Note.

Back up RAM data lost

A check sum error in the Back up RAM was detected. If this message is displayed, check the back up RAMs, the batteries, and the charger circuit on the A6 board.

CPUB RAM R/W error, nnnnnnH

A read/write error was detected in the A8 board's static RAM, where nnnnnnH is the address in hexadecimal where the read/write error occurred. If this message is displayed, troubleshoot the A8 board using signature analysis. For signature analysis information, refer to the 16349A's Operation Note.

EEPROM check sum error

A check sum error in EEPROM was detected. Measurement accuracy will be degraded. Troubleshoot the A8 board and recalibrate the EEPROM. To update the calibration information in EEPROM refer to the 16349A's Operation Note.

Figure 8-18. Power-On Self Test Error Messages (Sheet 2 of 2)

A6					A8						
DS1	DS2	DS3	DS4	DS5	DS1	DS2	DS3	DS4	DS5	DS6	
lit	-	-	-	-	-	-	-	-	-	-	see A
-	lit	-	-	-	lit	-	-	-	-	-	see B
-	-	lit	-	-	-	lit	-	-	-	-	see C
-	-	-	lit	-	-	-	lit	-	-	-	see D
-	-	-	lit	-	-	-	-	-	lit	-	see E
-	-	-	-	lit	-	-	-	-	lit	-	see F
-	-	-	-	lit	-	-	-	-	-	lit	Pass

A; A6 ROM check sum error was detected.
 B; A8 ROM check sum error or A6 DRAM read/write error was detected.
 C; A8 DRAM addressing test error or A8 DRAM clear test error was detected.
 D; A8 SRAM test error was detected.
 E; Stopped by A6 software error.
 F; Stopped by A8 software error.

Figure 8-19. Power-on Self Test LED Indications

8-28. HARDWARE RELATED ERROR MESSAGES

Table 8-4 lists some possible hardware related error messages and their detector circuits (detection signal names). An ac overload can be detected by the hardware detectors and by the A-D converter's count value.

Table 8-4. Error Messages

Error Message	Detection
AC current overload	IF-OVLD\ (A21U9)
AC overload on Rch input	IF-OVLD\ (A21U9) and AC-OVLD-R\
AC overload on Tch input	IF-OVLD\ (A21U9) and AC-OVLD-T\
AC voltage overload	IF-OVLD\ (A21U9)
Bridge unbalanced	BRG-UNBAL (A23U5)
DC current overload	BIAS-OVLD-D (A23U2) or BIAS-OVLD-S (A24U20)
DC voltage overload	DC-V-OVLD\ (A20U4)
Fractional N Loop + unlock	FN-UNLCK\ and UNLCK-STATE (A11U34)
Fractional N Loop - unlock	FN-UNLCK\ and UNLCK-STATE (A11U34)

8-29. FAULTY BOARD ISOLATION

Figure 8-20 is the Faulty Board Isolation Flow Diagram. Follow the flow diagram to find the faulty board, then troubleshoot the faulty board using the appropriate service sheet.

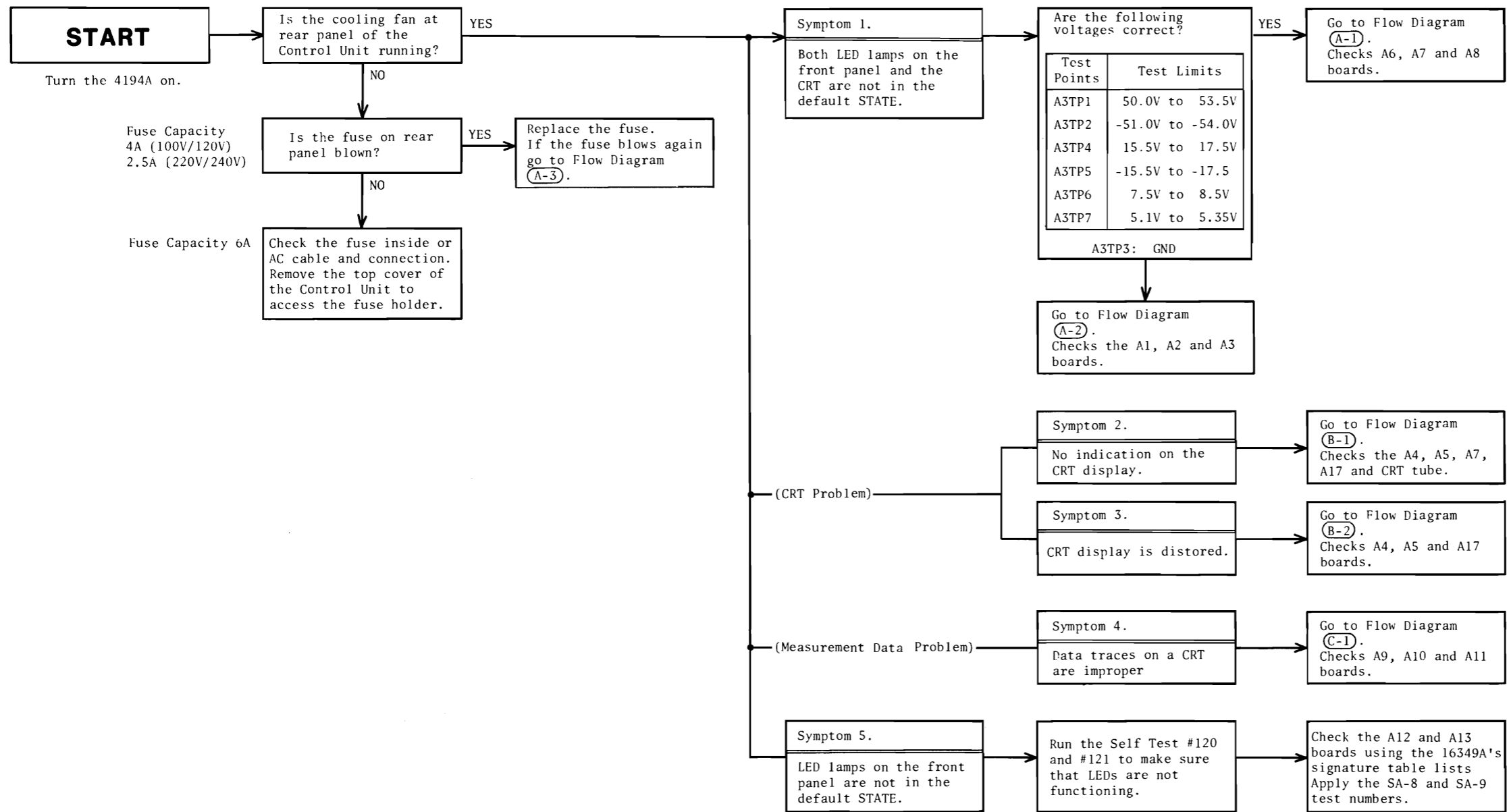
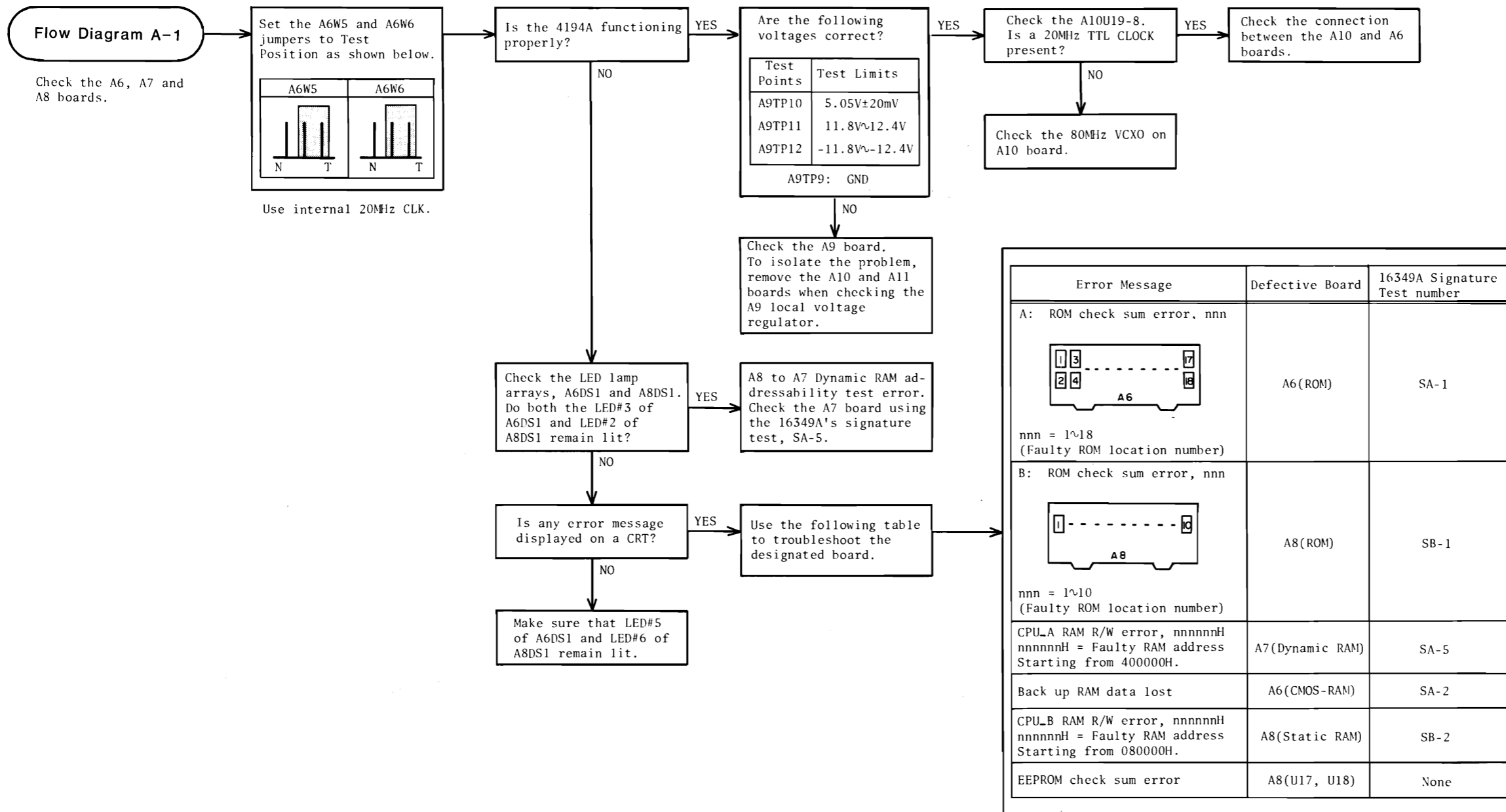

Figure 8-20. Faulty Board Isolation Flow Diagram (sheet 1 of 8)



NOTE

The 16349A signature lists are different in according to the instrument's ROM version number. Confirm the ROM version number first then apply the correct lists.

Figure 8-20. Faulty Board Isolation Flow Diagram (sheet 2 of 8)

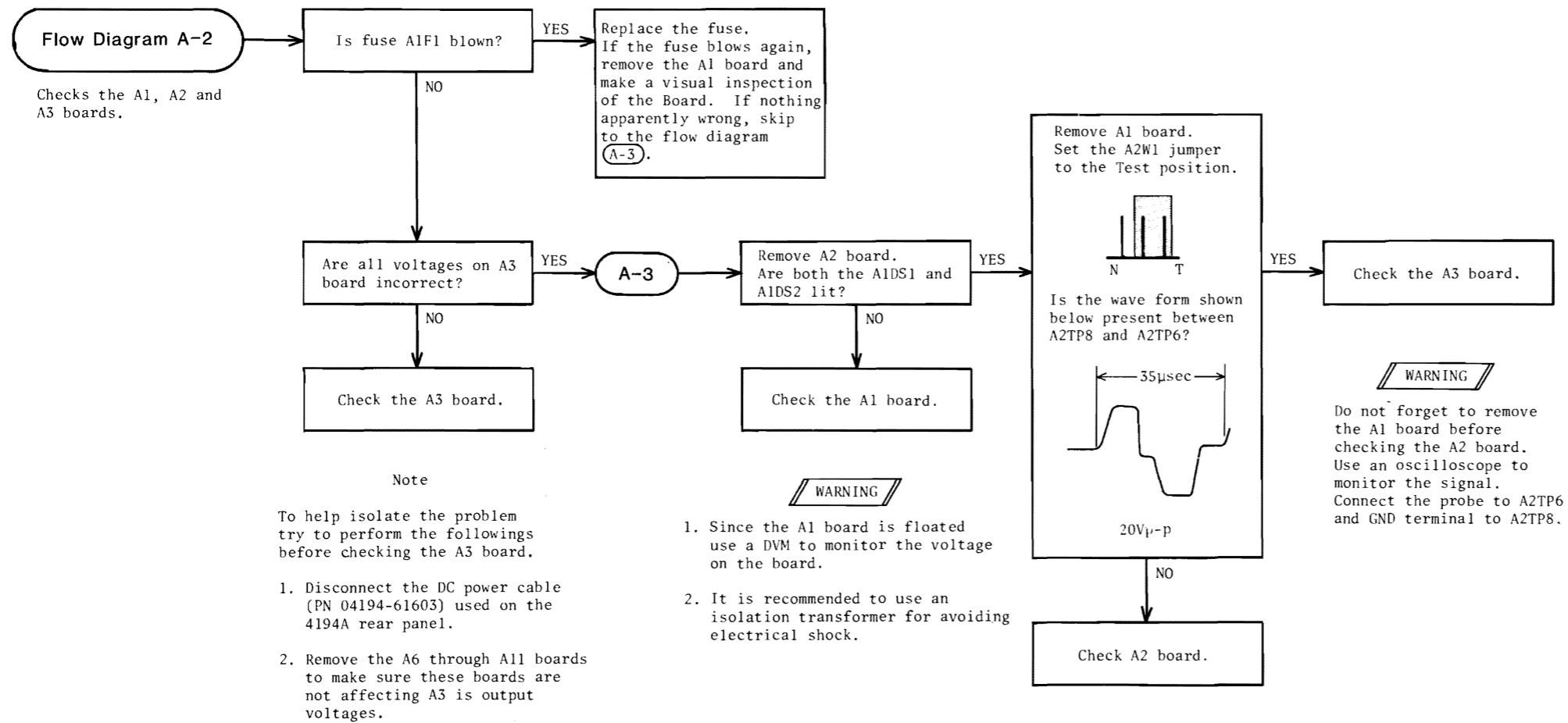

Figure 8-20. Faulty Board Isolation Flow Diagram (sheet 3 of 8)

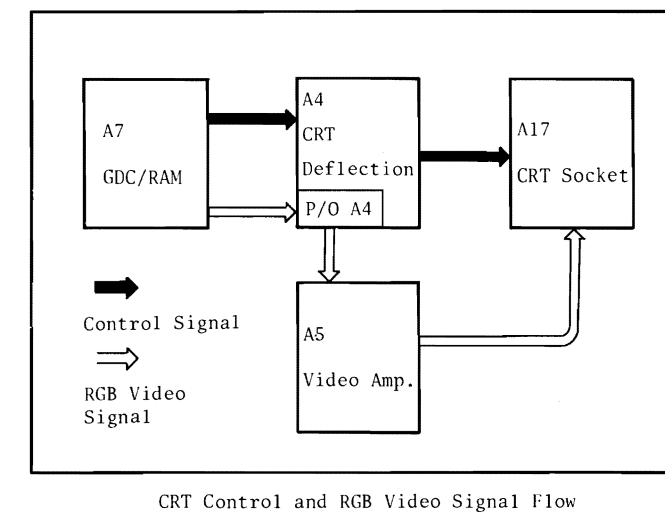
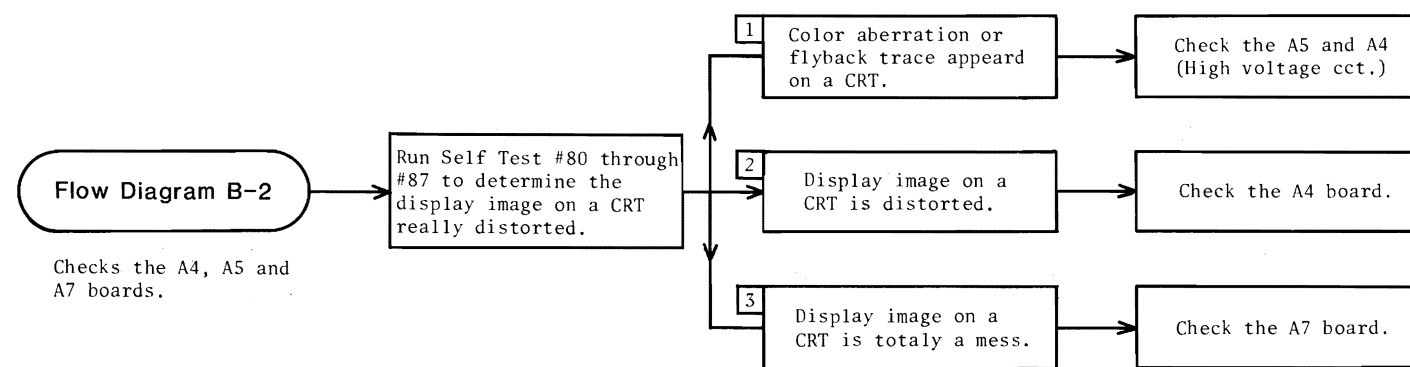
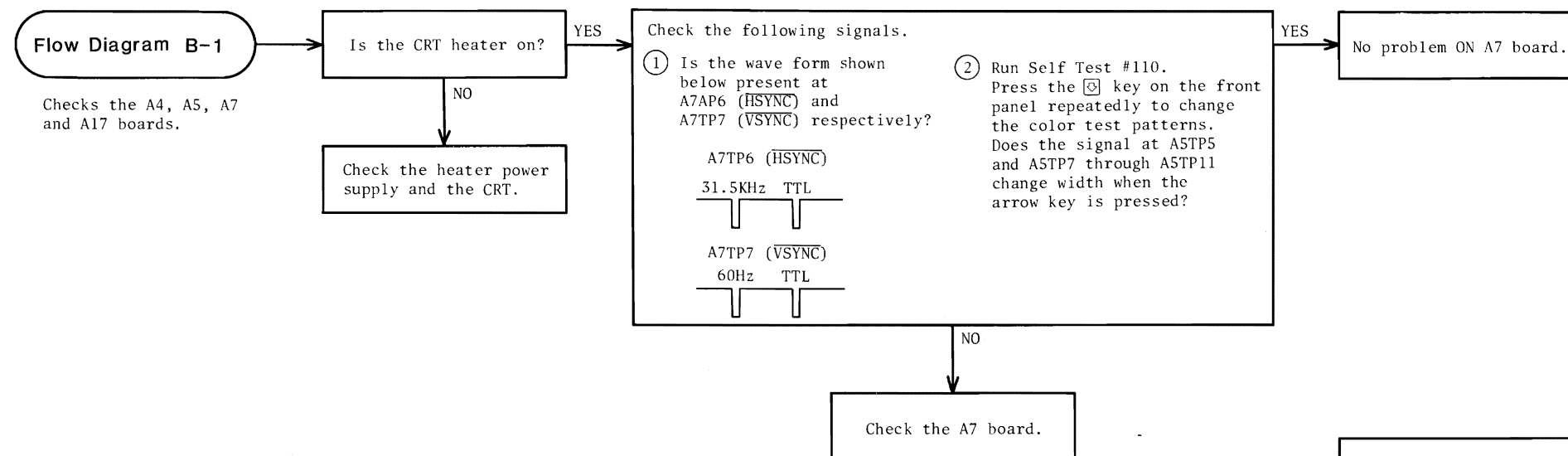
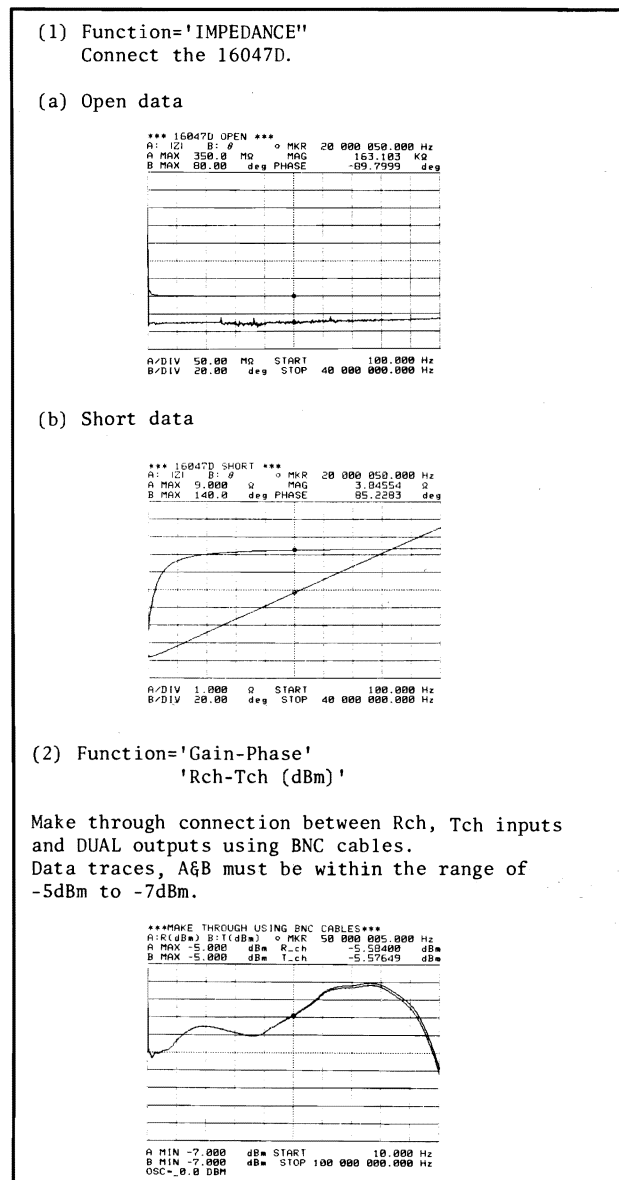
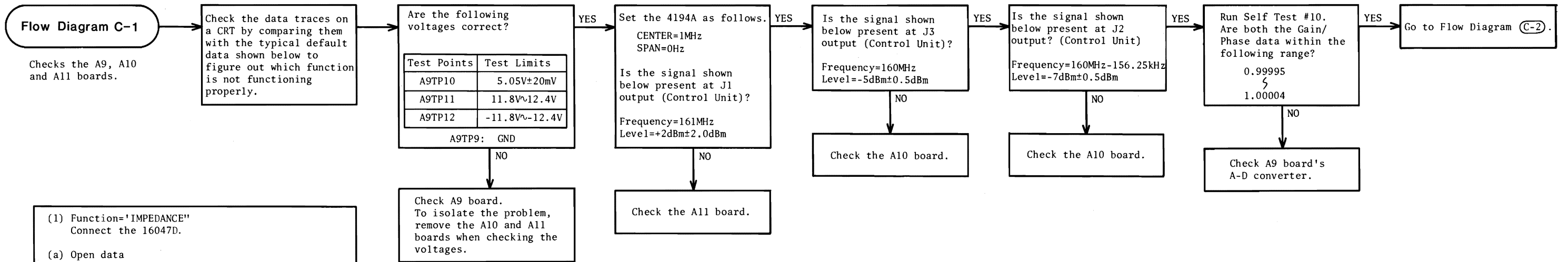

Figure 8-20. Faulty Board Isolation Flow Diagram (sheet 4 of 8)



Typical Default Data (No Compensation)

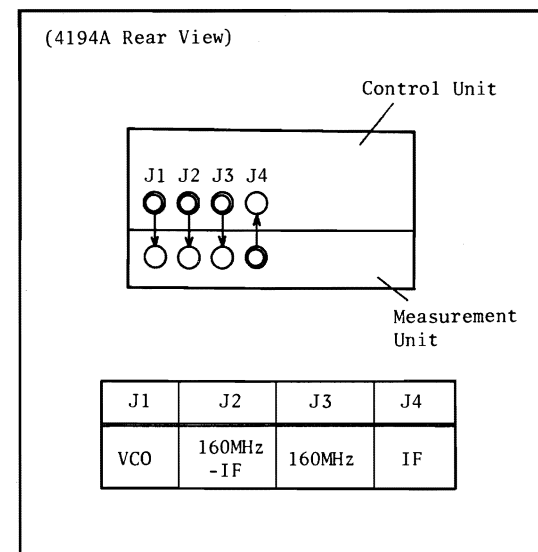

Figure 8-20. Faulty Board Isolation Flow Diagram (sheet 5 of 8)

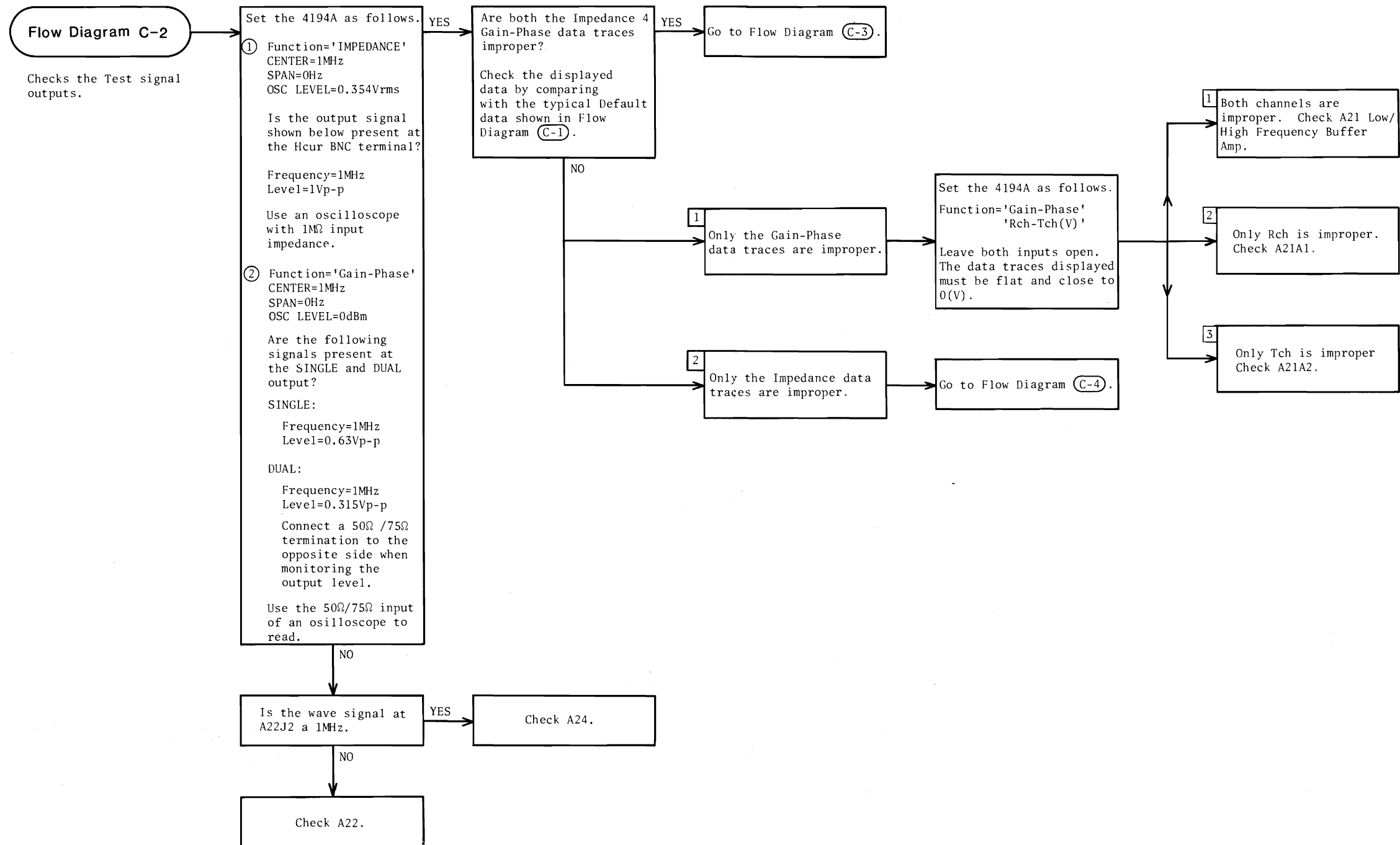

Figure 8-20. Faulty Board Isolation Flow Diagram (sheet 6 of 8)

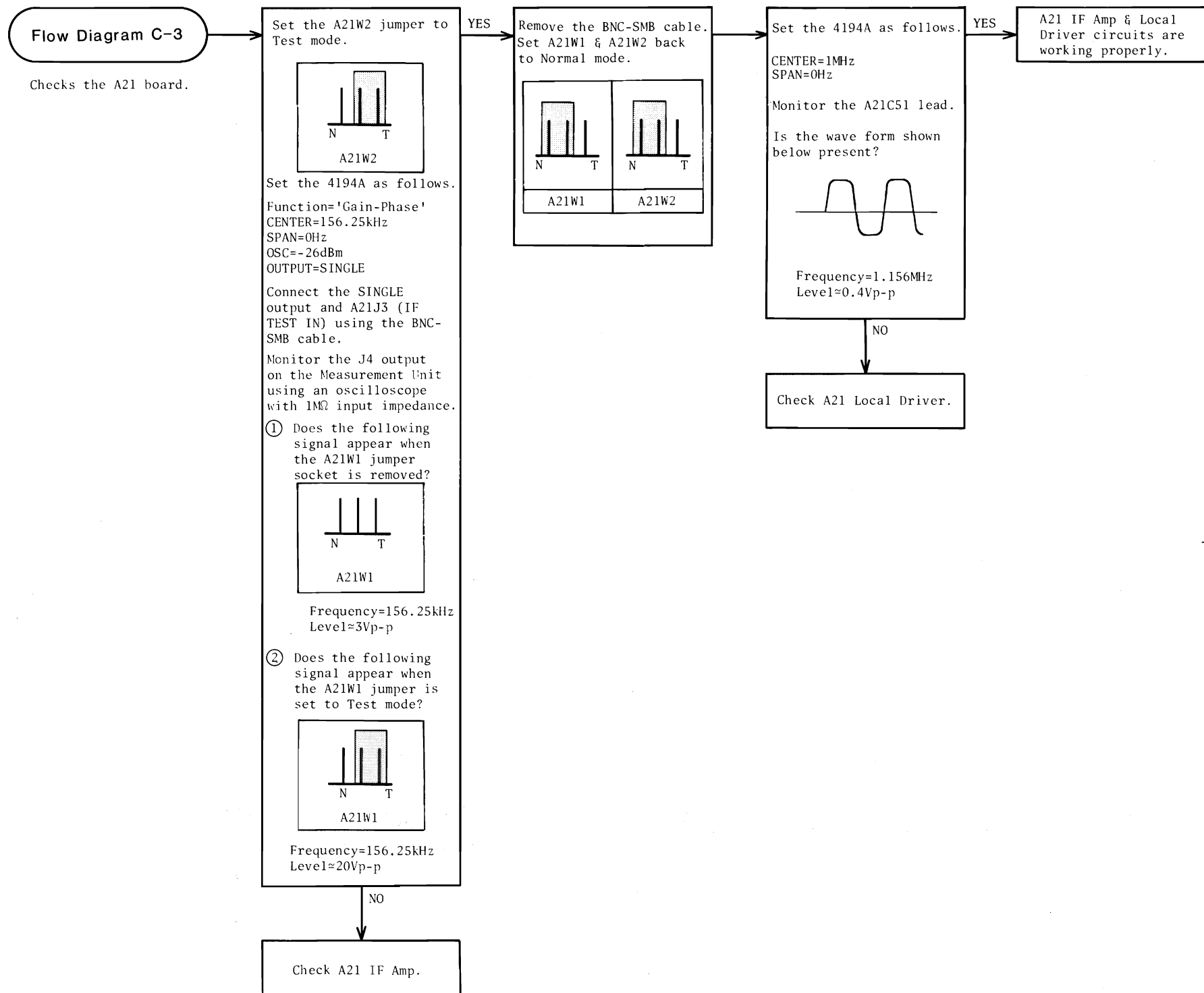

Figure 8-20. Faulty Board Isolation Flow Diagram (sheet 7 of 8)

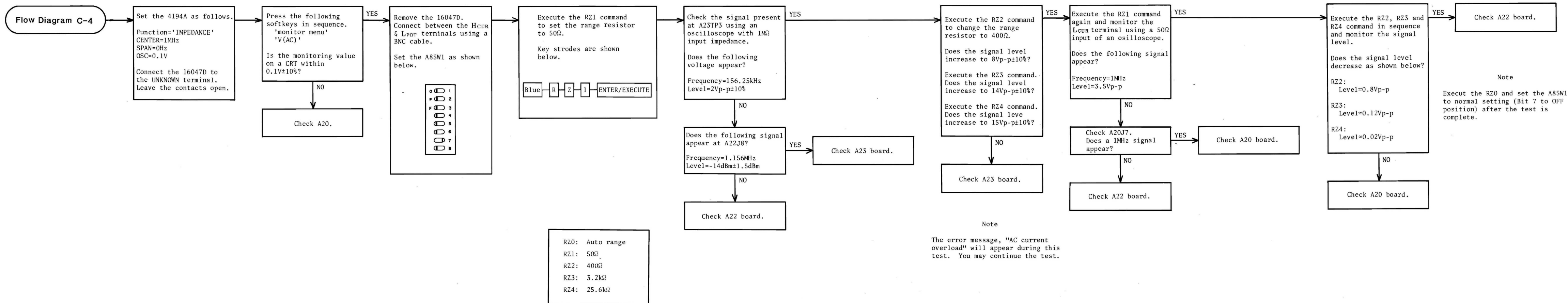

Figure 8-20. Faulty Board Isolation Flow Diagram (sheet 8 of 8)

CONTROL UNIT SERVICE SHEETS

- A1/A2/A3 Power Supply Service Sheet**
- A4/A17 CRT Deflection Service Sheet**
- A5 Video Amplifier Service Sheet**
- A6 Data Manipulation Processor Service Sheet**
- A7 GDC/RAM Service Sheet**
- A8 Measurement Control Processor Service Sheet**
- A9 Phase Detector/A-D Converter Service Sheet**
- A10 Reference Frequency Generator Service Sheet**
- A11 Fractional N Loop Service Sheet**
- A12/A13 Control Unit Keyboard Service Sheet**

**THIS PAGE
INTENTIONALLY BLANK.
INSERTED HERE FOR
DOCUMENT
PAGE NUMBER
CONTINUITY**

**SCANS
BY
ARTEK-MANUALS**

A1/A2/A3 POWER SUPPLY SERVICE SHEET

The A1, A2, and A3 boards contain the power supply circuits that provide 5V, 7V, $\pm 16V$, and $\pm 51V$ to the A15 motherboard. The turn on surge current limiter and primary rectifier are on the A1 board. The supply voltage controller, slow start circuit, and the FETs used in the switching power supply are located on the A2 board. The A3 board contains a transformer, a rectifier, an over voltage detector and a thermal switch.

The line voltage is rectified on the A1 board and is used as the unregulated dc voltage source. A1CR1 acts as a full wave rectifier when the line voltage selector is set to 220/240V, and as a voltage doubler when the line voltage selector is set to 100/120V. The surge current limiter limits the current when the instrument is turned on. A1K1 is activated by the slow start circuit about one second after the power switch is turned on to by-pass A1R7 (surge current limit resistor).

A1R7 protects A1CR1, A1C6, A1C7, A1C8, A1C9, and A1C10 from the surge current at power up. If K1 does not activate, A1FT1 (thermal fuse) will blow due to the heat produced by A1R7.

A2C20, A2C21, A2Q11 and A2Q12 on the A2 board make up the switching circuit which converts dc to 30kHz ac. The duty cycle is the parameter varied to maintain constant output voltages. A2U1 controls the duty cycle by comparing the 5V reference voltage to the 8V output voltage. A2U1 shuts down the switching circuit when it detects a shut down condition on the A3 board (over voltage) or an over current condition detected by A2R28. A2U2 supplies 12V to A2U1. The slow start circuit is made up of A2Q1, A2Q2, A2Q6, A2Q7, A2Q8, A2Q9 and A2Q10. If the voltage from the A1 board reaches 210V, A2Q8 will turn on and the darlington pair, A2Q9 and A2Q10, will activate A1K1.

When A2W1 is set to the test position, the drive signal's duty cycle is set to about 50%, and can be monitored at A2U1 to check circuit operation.

Scans by Artekmedia => 2010

WARNING

REMOVE THE A1 BOARD WHEN A2W1 IS SET TO THE TEST POSITION OR UN-REGULATED VOLTAGE WILL BE SUPPLIED TO THE OTHER BOARDS AND THEY WILL BE DAMAGED.

The output voltage from the A2 board is stepped down by transformer A3T3, rectified, and output as 5V, 7V, $\pm 16V$ and $\pm 51V$. The dc voltage produced by A3CR20, A3CR21, A3L2 and A3C12 is the feedback voltage to A2U1. Thermal switch A3ST1 is used to protect the 4194A if it begins to overheat for any of the following reasons: heat generated by a power supply failure, the fan stops, or by heat generated from other failures within the instrument. When A3ST1 turns on, A3Q2, the photo coupler and A3Q3 will turn on, sending a shutdown signal to A2U1. CR2, CR4, CR5 and CR6 make up the over voltage detector. If any voltage exceeds its limit the over voltage detector will send a shutdown command, A3Q2 (photo coupler), and A3Q3 will turn on, sending the shutdown signal to A2U1.

Table PS-1. Power Supply Troubleshooting Data

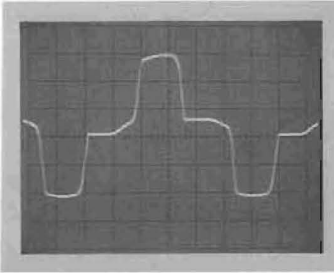
Step	HP 4194A Settings	Measurement Setup	Main Parameters	Waveform
1	Remove A1 board. A2W1: Test position	Oscilloscope 5 μ s/DIV CH-A to A2TP6 dc coupled 5V/DIV GND to A2TP8	Cycle Duty Amplitude	

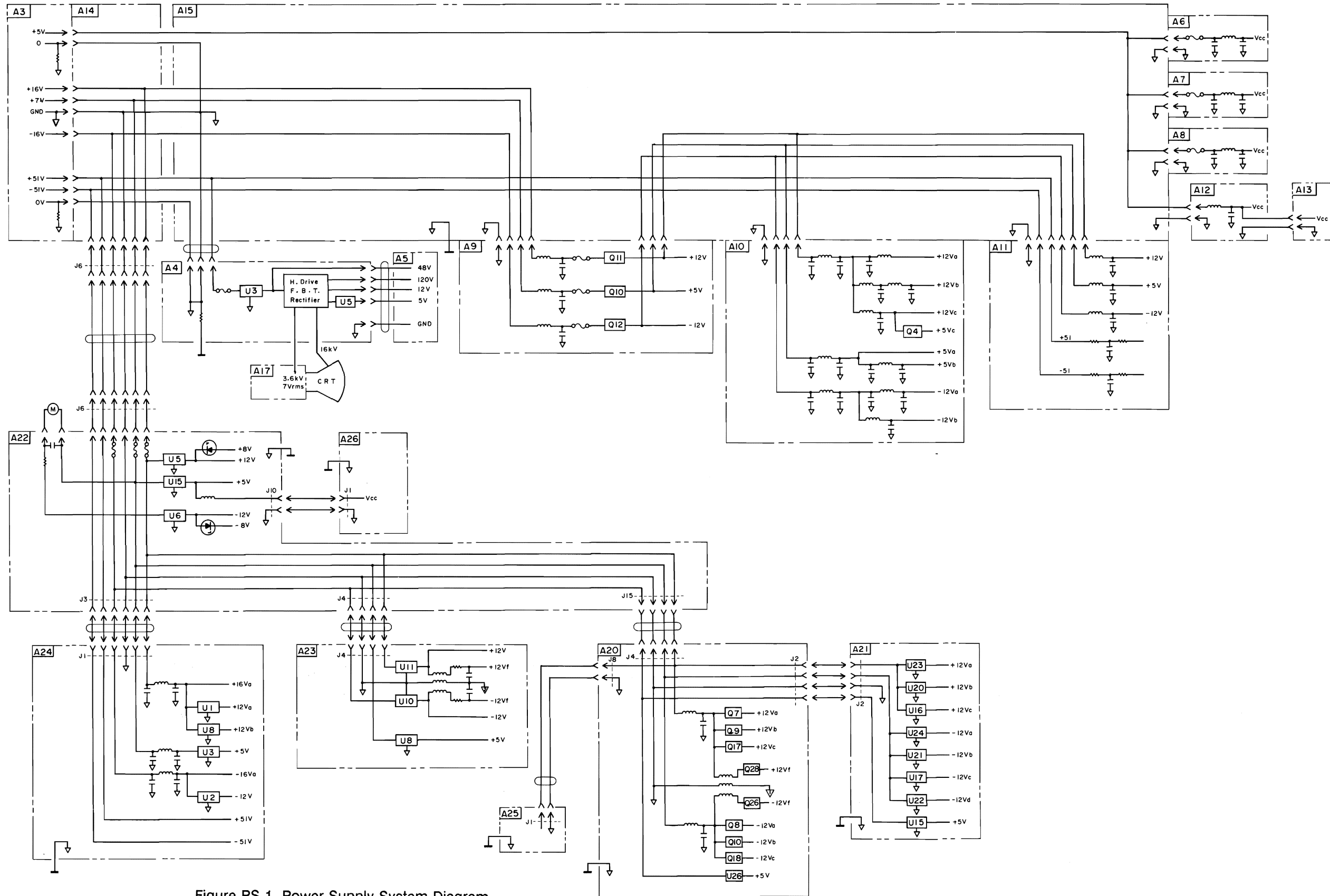
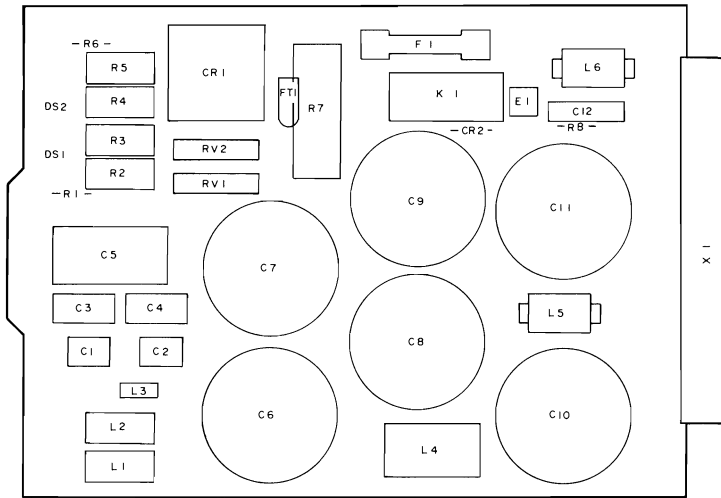
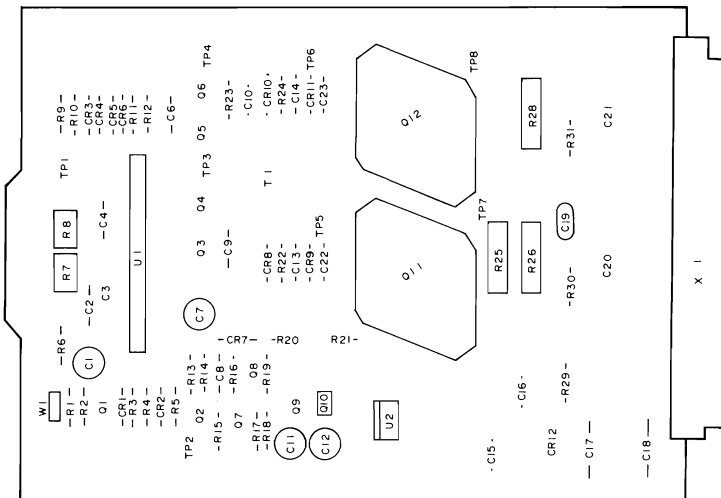

Figure PS-1. Power Supply System Diagram



A1 Primary Rectifier Component Locations



A2 Power Supply Control Component Locations

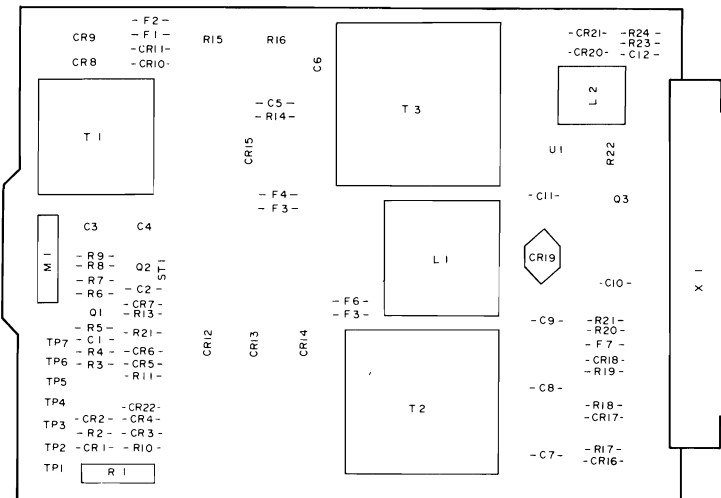

A3 Power Supply Output Component Locations

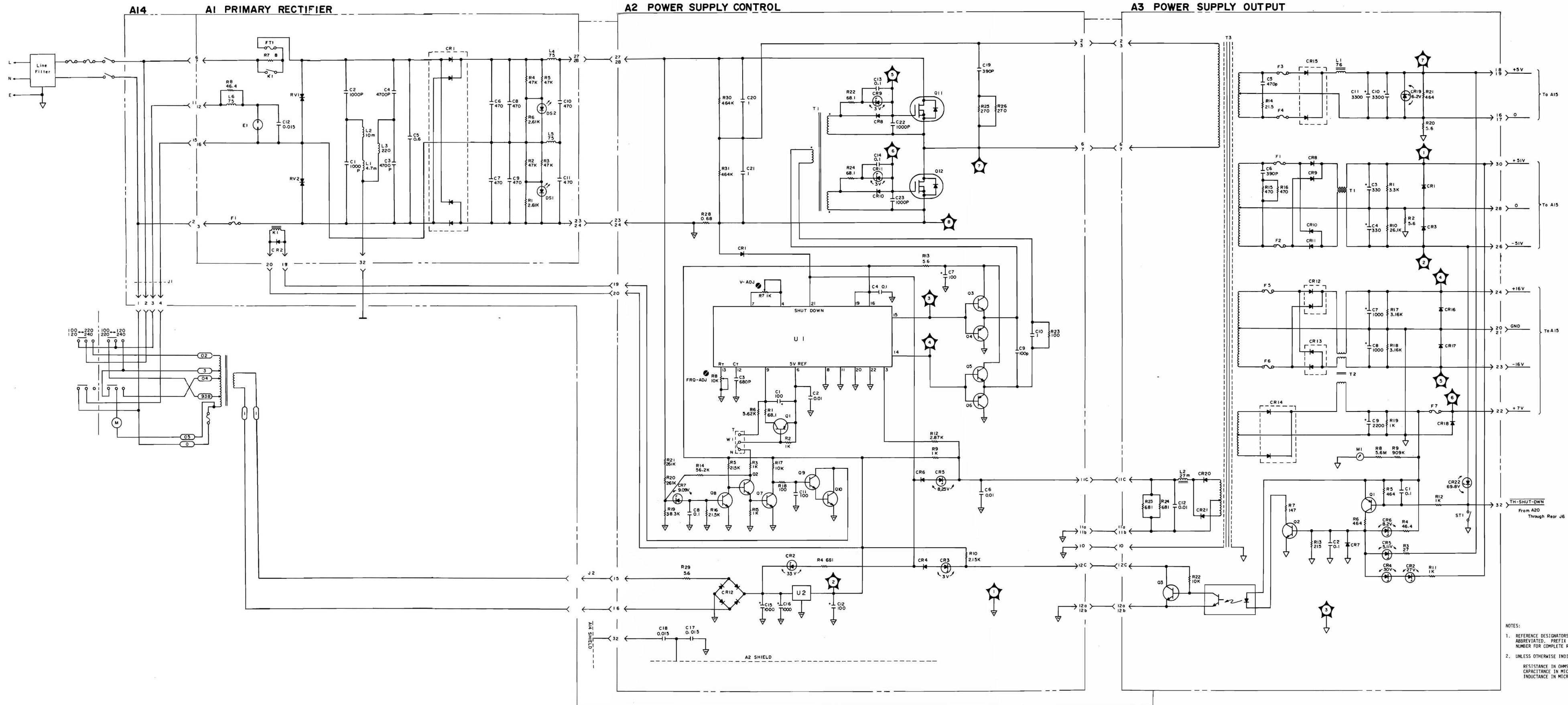

NOTES:
 1. REFERENCE DESIGNATORS WITHIN THIS ASSEMBLY ARE ABBREVIATED. PREFIX ABBREVIATION WITH ASSEMBLY NUMBERS FOR COMPLETE REFERENCE DESIGNATOR.
 2. UNLESS OTHERWISE INDICATED:
 RESISTANCE IN OHMS (Ω)
 CAPACITANCE IN MICROFARADS (μF)
 INDUCTANCE IN MICROHENRIES (μH)

A1/A2/A3 Power Supply Schematic Diagrams

A4 (A17) CRT Deflection Service Sheet

Figure A4-1 shows the block diagram of the A4 CRT deflection board, and the A17 CRT socket board.

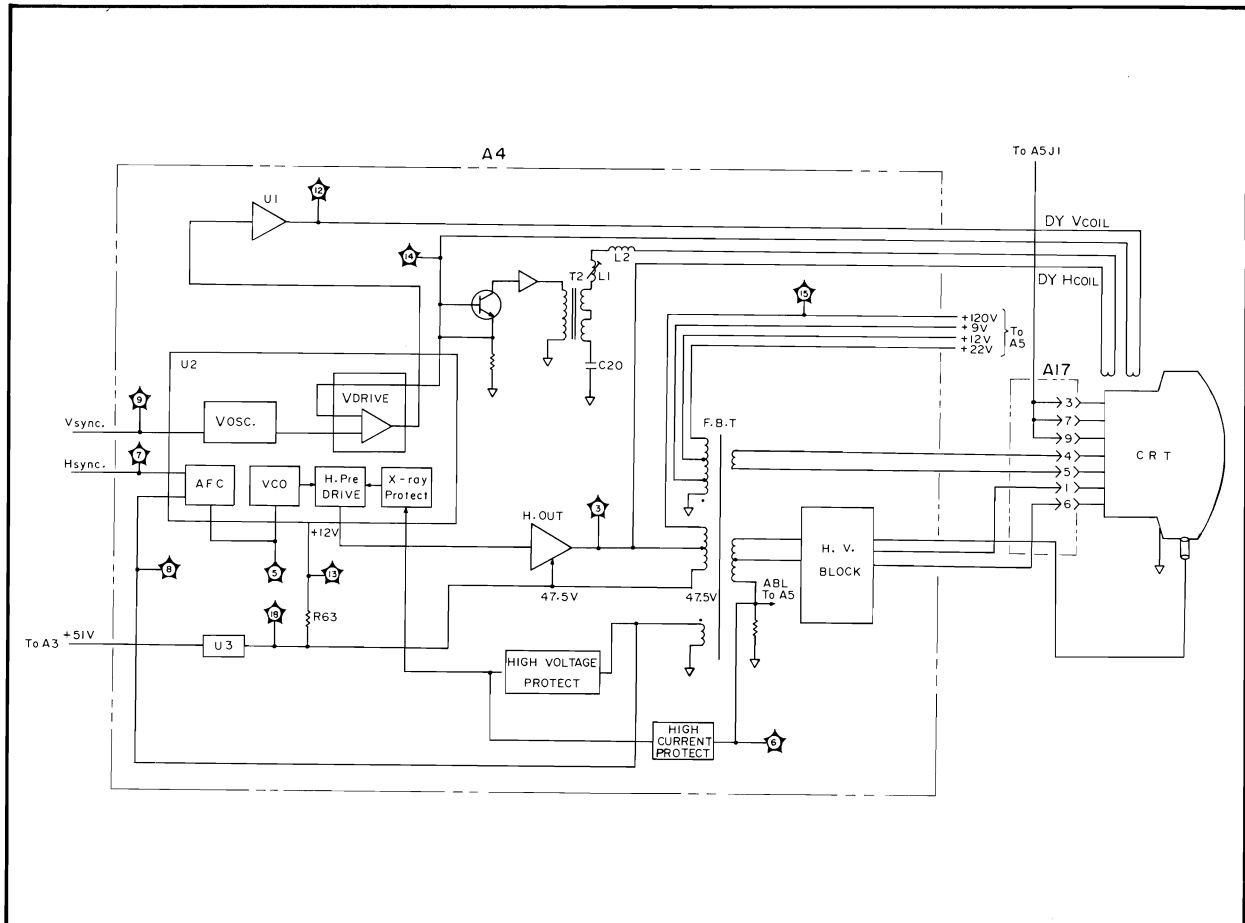

Figure A4-1. A4 Board and A17 Board Block Diagram.

The A4 board generates the deflection yoke drive signal, and supplies 5V, 12V, 48V, 120V (to the A5 board), 22V (to the A4 board), and the 16kV anode voltage using a Fly Back Transformer (F.B.T.) to the CRT. A4U2 generates the vertical drive signal (a sawtooth current) and the horizontal drive signal (rectangular voltage waveform). H.OUT is composed of A4Q1, A4T1, A4Q5, A4CR6, A4C31 and A4C32. H.OUT converts the horizontal drive signal into a sawtooth current. The saw tooth current produces three types of distortion: S character distortion, linearity distortion, pincushion distortion. S character distortion is minimized by the resonate frequency of A4C20 and the DY coil, and the linearity distortion is minimized by the dc current-inductance characteristics of A4L2. Pincushion distortion is minimized by A4T2 which transforms the parabolic current produced by the vertical deflection yoke signal into the primary current. A4U2's X-ray protect circuit prevents X-rays from being produced by protecting the CRT anode from excessive current and voltage.

The high voltage protect circuit is composed of A4CR4, A4R28, A4R29, A4R30, and A4R31. When the voltage at the junction of voltage dividers A4R28 and A4R29 is greater than approximately 10V, CR5 turns on, and the X-ray protect circuit shuts down the horizontal drive. The over current protect circuit is composed of A4Q6 and A4Q7. When the voltage at A4TP6 is greater than -0.7V, A4Q6 and A4Q7 turn on, and the X-ray protect circuit shuts down the horizontal drive signal. The auto brightness limiter (ABL), detects the anode current, and when the cathode voltage of A4C10 is greater than approximately -1.4V the ABL circuit functions. A4U2's AFC (Auto Frequency Control) uses feedback to stabilize the VCO and transmits H sync to the VCO. A4U3 supplies +47.5V to A4T1 (F.B.T.) and supplies 12V (through A4R63) to A4U2. The H.V. Block controls the focus and convergence voltage.

When A4W3 is set to the test position, V.OSC doesn't oscillate, only the H.drive signal is present. The color signal voltage is controlled by A5R4, A5R11 and A17R1. The A17 board interfaces the signals from the A4 and A5 board to the CRT.

Table A4-1. A4 Troubleshooting Data (1 of 2)

Step	HP 4194A Settings	Measurement Setup	Main Parameters	Waveform
1		Oscilloscope 10 μ s/DIV CH-A to TP7 dc coupled 2V/DIV	dc offset Amplitude Duty	
2		Oscilloscope 10 μ s/DIV CH-A to TP5 dc coupled 5V/DIV	Wave shape Amplitude Cycle	
3		Oscilloscope 10 μ s/DIV CH-A to TP1 dc coupled 50V/DIV	Cycle Duty	
4		Oscilloscope 10 μ s/DIV CH-A to TP3 dc coupled 100V/DIV	Amplitude	
5		Oscilloscope 5ms/DIV CH-A to TP2 dc coupled 2V/DIV	Wave shape (parabolic)	

Table A4-1. A4 Troubleshooting Data (2 of 2)

Step	HP 4194A Settings	Measurement Setup	Main Parameters	Waveform
6		Oscilloscope 5ms/DIV CH-A to TP9 dc coupled 5V/DIV	Amplitude Duty	
7		Oscilloscope 5ms/DIV CH-A to TP4 dc coupled 10V/DIV	Wave shape Amplitude Cycle	
8		Oscilloscope 5ms/DIV CH-A to TP12 dc coupled 10V/DIV	dc offset Amplitude Wave shape	 GND level: One DIV from bottom of CRT
9		Oscilloscope 10µs/DIV CH-A to TP8 dc coupled 2V/DIV	Cycle Amplitude	
10		Oscilloscope 5ms/DIV CH-A to TP11 dc coupled 5V/DIV	dc offset	



A4 CRT Deflection Component Locations

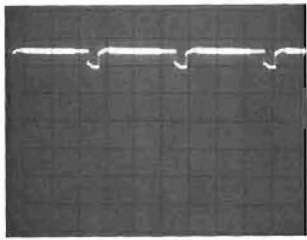
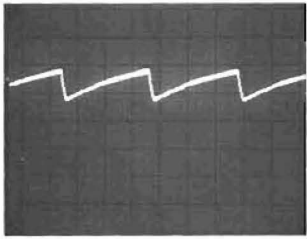
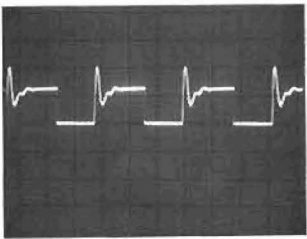
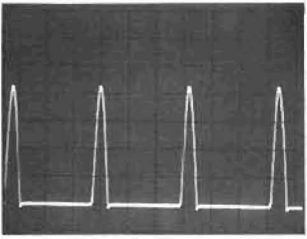
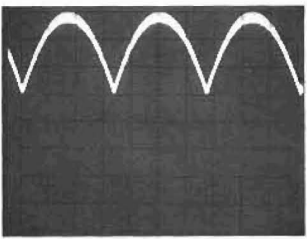
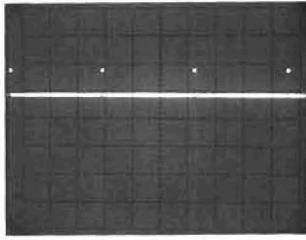
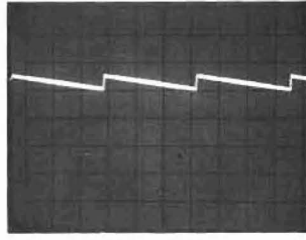
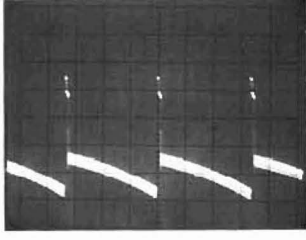
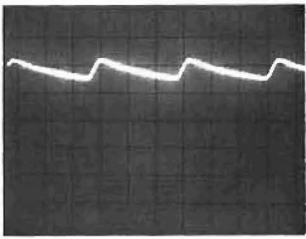
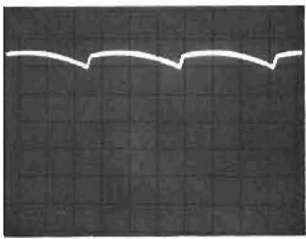
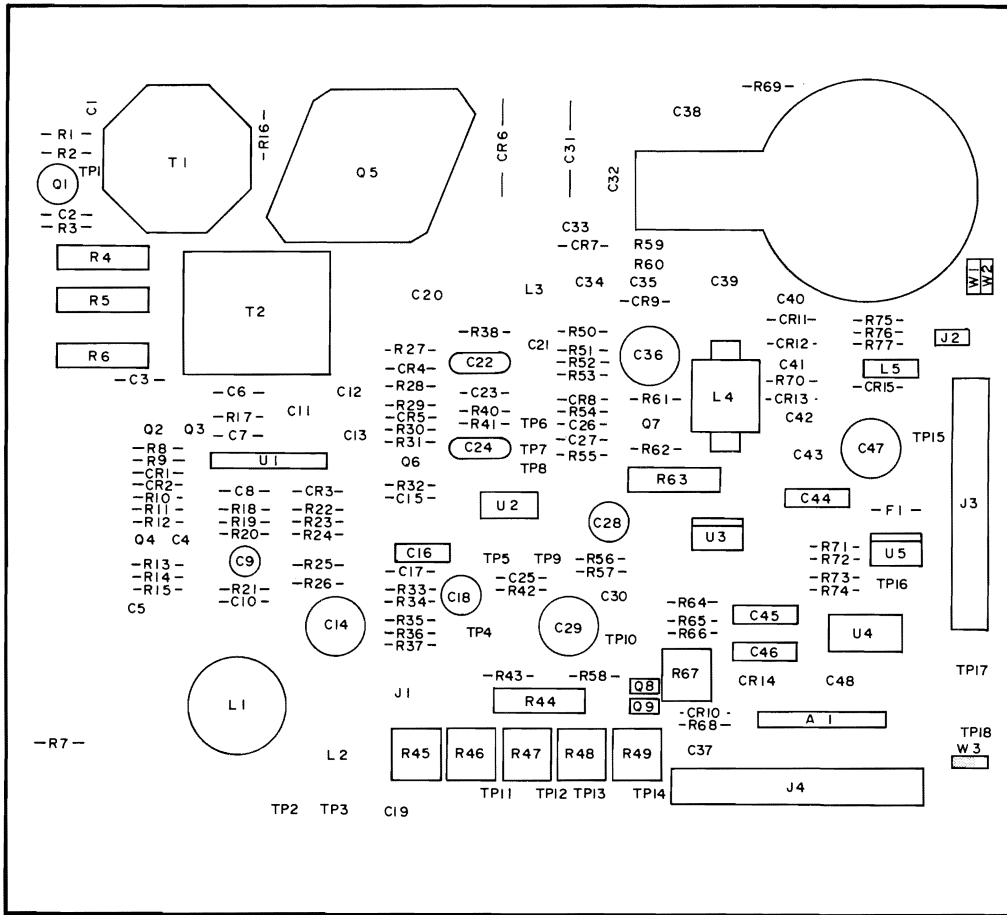
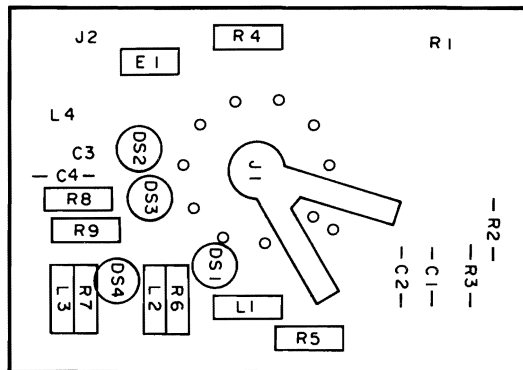

A17 CRT Socket Component Locations

A4 CRT DEFLECTION

A17 CRT SOCKET

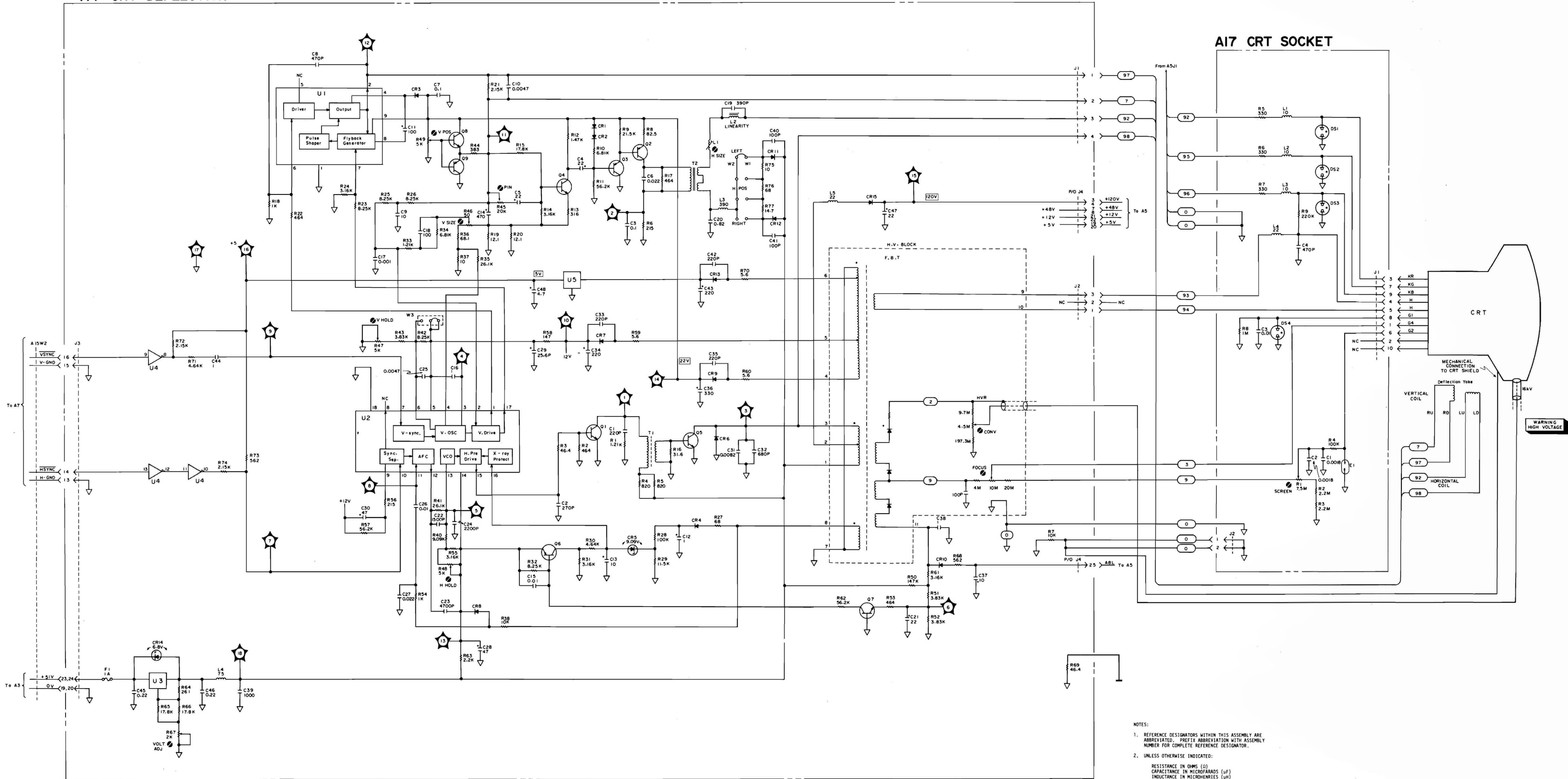

NOTES:
1. REFERENCE DESIGNATORS WITHIN THIS ASSEMBLY ARE ABBREVIATED. PREFIX ABBREVIATION WITH ASSEMBLY NUMBER FOR COMPLETE REFERENCE DESIGNATOR.
2. UNLESS OTHERWISE INDICATED:
RESISTANCE IN OHMS (Ω)
CAPACITANCE IN MICROFARADS (μF)
INDUCTANCE IN MICRORHENRIES (μH)

A4 CRT Deflection and A17 CRT Socket Schematic Diagrams

A5 Video Amplifier Service Sheet

Figure A5-1 is a block diagram of the A5 video amplifier board which amplifies the red, green, and blue color signals used to drive the CRT. Each color signal consists of 2 bits. The value of each 2 bit signal passing through A5U1 can be modified using the following weighting resistors, red: A5R21, A5R29, green: A5R32, A5R33, and blue: A5R30, A5R31.

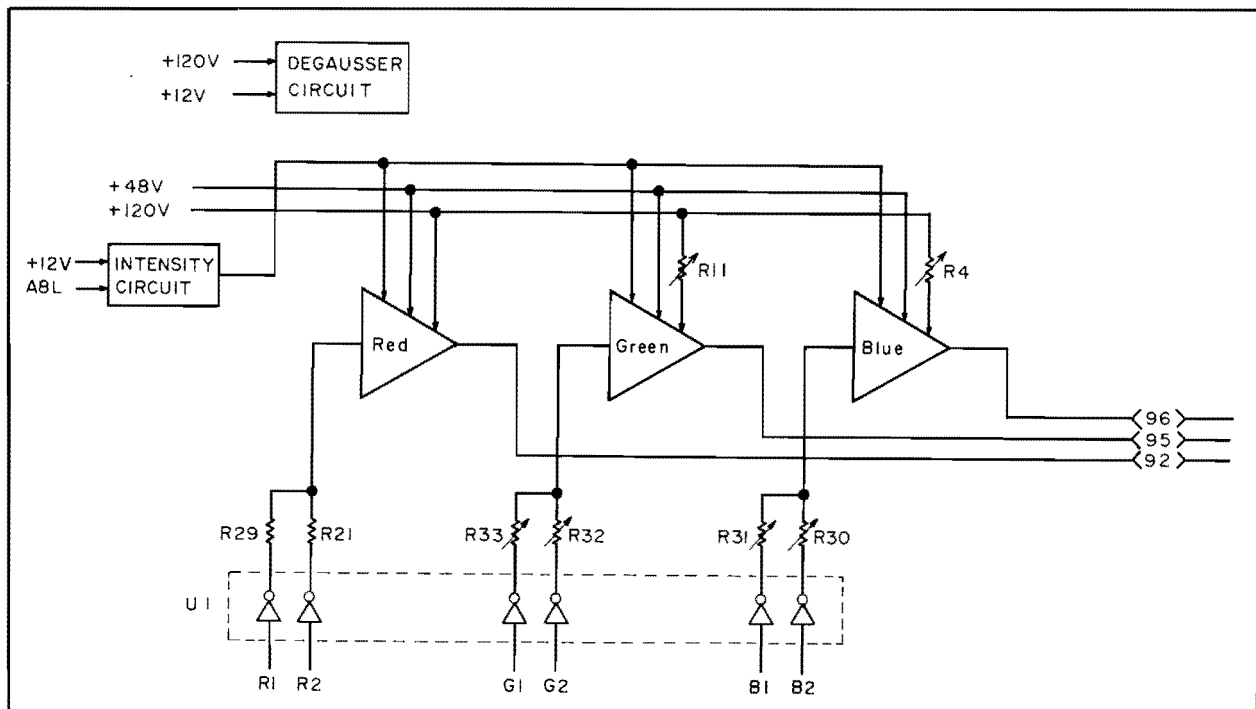

Figure A5-1. A5 board Block Diagram

As an example, we will trace the RED color signals. The red color signal is a composite of the R1 and R2 color signals. If signal R1 is low, U1's output will be high, current does not flow through R29 and Q9, and the output voltage of A5Q5 and A5Q6 will be pulled up to 48V. If color signal R1 is high, A5U1's output will be low, and the current flowing through A5Q9 is determined by the value of the INTENSITY voltage and the resistance of A5R29. Therefore the amplitude of A5Q5 and A5Q6 output will be high if either the voltage from the INTENSITY potentiometer is decreased or if a lower value weighting resistor is selected.

The **INTENSITY** voltage is adjusted with the INTENSITY pot, A5R34, and by the ABL signal. When the ABL circuit is active, the current through A5Q12 decreases and the INTENSITY voltage decreases. The outputs of A5Q5 and A5Q6 are decoupled by A5C7. The upper limit of its waveform is clamped to approximately 97V, the voltage at A5R7 and A5R10. The upper limits of the green and blue signals are adjustable, $97V \pm 20V$, using the CUTOFF control resistors (green: A5R11, blue: A5R4). The weighted resistor (A5R21) for color signal R2 is one-half the value of A5R29, and the R2 color signal produces twice the brightness as the R1 color signal. The Green color signal circuit and the blue color signal circuits use the same circuit as the red color circuit. Each color signal has four brightness levels.

The degaussing circuit erases the magnetism of the CRT frame and the aperture grille. Voltage is not applied to A5CR11 when the instrument is turned on. A5CR11 will conduct when A5Q10 and A5Q14 turn on. A series resonate circuit, consisting of A5Q10, A5C12, and A5L5, is formed which causes a damped oscillation current to flow. When A5C13 is discharged, A5Q10 turns off, and the series resonant circuit is broken.

Table A5-1. A5 Troubleshooting Data

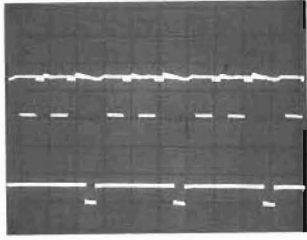
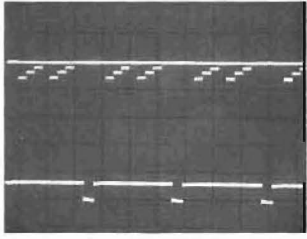
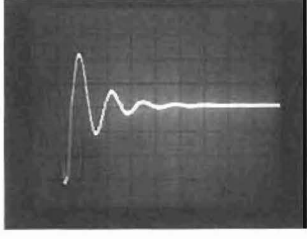
Step	HP 4194A Settings	Measurement Setup	Main Parameters	Waveform
1	Self Test #86	Oscilloscope 10 μ s/DIV CH-A to TP5 dc coupled 2V/DIV CH-B to A4TP7 TRIGGER:CH-B	Max. voltage depends on the INTENSITY	
2	Self Test #87	Oscilloscope 10 μ s/DIV CH-A to: TP4 (red) TP3 (green) TP2 (blue) dc coupled 50V/DIV CH-B to A4TP7 TRIGGER:CH-B		
3	Turn the 4194A off, then back on.	Oscilloscope 500 μ s/DIV CH-A to J3-1 dc coupled 20V/DIV		

A5 Video Amplifier Component Locations

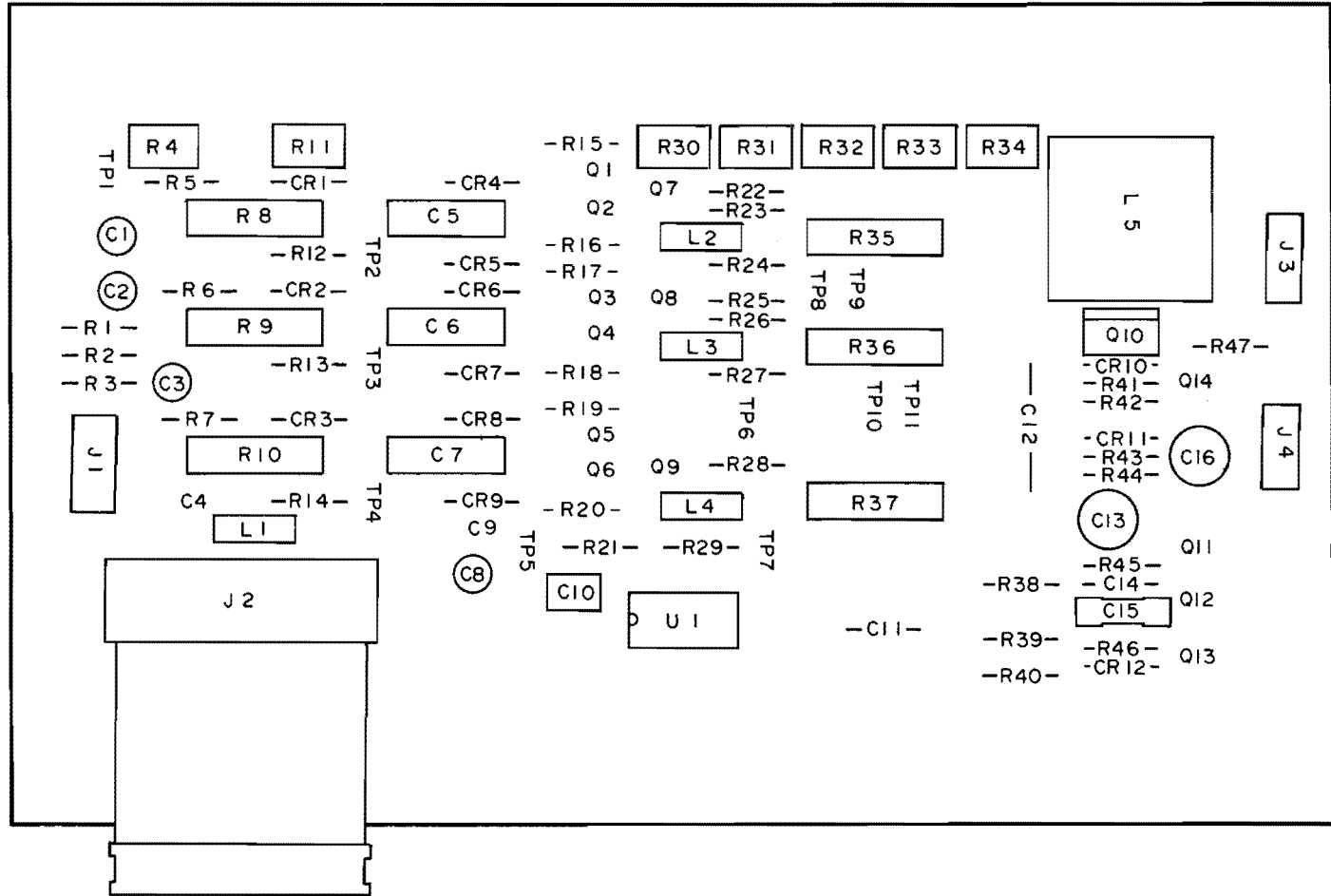

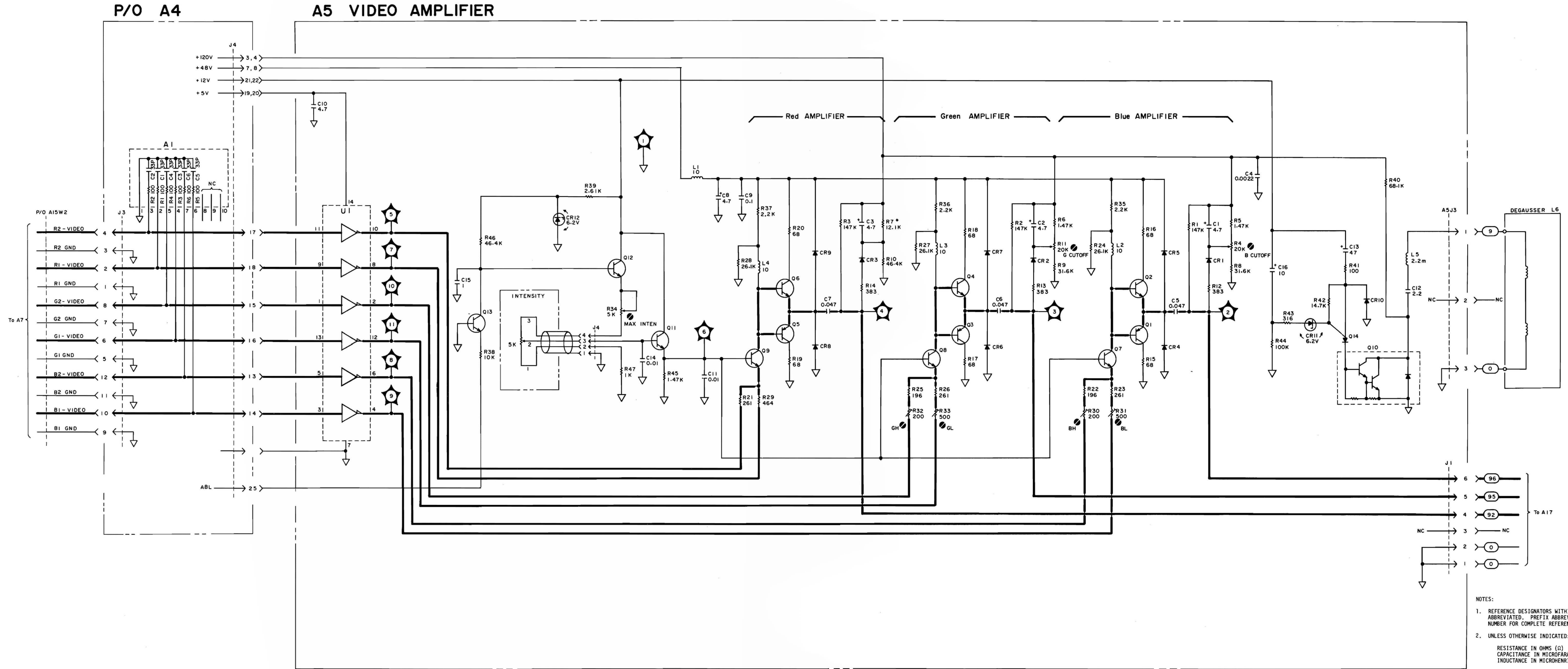

NOTES:

1. REFERENCE DESIGNATORS WITHIN THIS ASSEMBLY ARE ABBREVIATED. PREFIX ABBREVIATION WITH ASSEMBLY NUMBER FOR COMPLETE REFERENCE DESIGNATOR.
2. UNLESS OTHERWISE INDICATED:
RESISTANCE IN OHMS (Ω)
CAPACITANCE IN MICROFARADS (µF)
INDUCTANCE IN MICRORHENRIES (µH)

A5 Video Amplifier Schematic Diagram

A6 Data Manipulation Processor Service Sheet

The A6 board contains CPU A, ROM, and battery backed-up RAM. CPU A calculates the parameters, and monitors the front panel keys. ASP programs, the "SAVE" storage area, the limit table, and data are stored in the battery backed up RAM.

CPU A	A6U34
ROM	A6U5 to A6U12 and A6U21 to A6U28
RAM	A6U43 to A6U48

CPU A (A6U34) uses a 10MHz clock which is derived by dividing the 20MHz signal from the A10 board in the analog section. CPU A interfaces with memory through address buffers. CPU A's 8 BIT INPUT/OUTPUT signals are buffered.

Table A6-1. A6 Troubleshooting Aids (1 of 3)

Reference Designator	Use																		
A6DS1 to DS8	DS1 to DS8 are used as power-on self test indicators. Refer to the Power-On Self Test.																		
A6DS9	When DS9 turns on, CPU A has stopped for a BUS ERROR. Cycle the power switch to reset the instrument.																		
A6SW1	<p data-bbox="444 531 1338 590">Normally all bits are set to the ON Position. SW1 is used to perform the functions shown below.</p> <table border="1" data-bbox="440 646 1307 1234"> <thead> <tr> <th data-bbox="440 646 537 703">SW</th> <th data-bbox="537 646 1307 703">FUNCTION</th> </tr> </thead> <tbody> <tr> <td data-bbox="440 703 537 751">SW1-1</td> <td data-bbox="537 703 1307 751">Set to ON. OFF is for design use only.</td> </tr> <tr> <td data-bbox="440 751 537 779">SW1-2</td> <td data-bbox="537 751 1307 779">NOT ASSIGNED</td> </tr> <tr> <td data-bbox="440 779 537 806">SW1-3</td> <td data-bbox="537 779 1307 806">NOT ASSIGNED</td> </tr> <tr> <td data-bbox="440 806 537 833">SW1-4</td> <td data-bbox="537 806 1307 833">NOT ASSIGNED</td> </tr> <tr> <td data-bbox="440 833 537 1031">SW1-5</td> <td data-bbox="537 833 1307 1031"> SW1-5's, position is determined by which option you have. ON: OPTION 350 OFF: OPTION 375 </td> </tr> <tr> <td data-bbox="440 1031 537 1079">SW1-6</td> <td data-bbox="537 1031 1307 1079">Set to the ON position. OFF is for design use only.</td> </tr> <tr> <td data-bbox="440 1079 537 1127">SW1-7</td> <td data-bbox="537 1079 1307 1127">NOT ASSIGNED</td> </tr> <tr> <td data-bbox="440 1127 537 1176">SW1-8</td> <td data-bbox="537 1127 1307 1176">Normally set to ON. Off is used for Signature Analysis.</td> </tr> </tbody> </table>	SW	FUNCTION	SW1-1	Set to ON. OFF is for design use only.	SW1-2	NOT ASSIGNED	SW1-3	NOT ASSIGNED	SW1-4	NOT ASSIGNED	SW1-5	SW1-5's, position is determined by which option you have. ON: OPTION 350 OFF: OPTION 375	SW1-6	Set to the ON position. OFF is for design use only.	SW1-7	NOT ASSIGNED	SW1-8	Normally set to ON. Off is used for Signature Analysis.
SW	FUNCTION																		
SW1-1	Set to ON. OFF is for design use only.																		
SW1-2	NOT ASSIGNED																		
SW1-3	NOT ASSIGNED																		
SW1-4	NOT ASSIGNED																		
SW1-5	SW1-5's, position is determined by which option you have. ON: OPTION 350 OFF: OPTION 375																		
SW1-6	Set to the ON position. OFF is for design use only.																		
SW1-7	NOT ASSIGNED																		
SW1-8	Normally set to ON. Off is used for Signature Analysis.																		

Table A6-1. A6 Troubleshooting Aids (2 of 3)

Reference Designator	Use																																																																								
A6SW2	<p>SW2 is used to perform the functions shown below. Normally all bits are set to the OFF Position.</p> <p>SW FUNCTION</p> <p>SW2-1 Normally set to OFF. ON selects the Free-run mode which is used for Signature Analysis.</p> <p>SW2-2 Normally set to OFF. ON is used to select the BUS-FLOAT state (tristate the bus). This is for manufacturing use only.</p> <p>SW2-3 Set to OFF. The ON position is for design use only.</p> <p>SW2-4 NOT ASSIGNED</p>																																																																								
A6W1, A6W2	<p>Normally set to POSITION 2. W1 and W2's positions depends on the ROM used.</p> <p>POSITION 1: 128Kbit ROM POSITION 2: 256Kbit ROM</p>																																																																								
A6W3, A6W4	<p>Set to the number 4 configuration. The position of number W3 and W4 are selected as shown below.</p> <p>Configuration 1 (eight 256K ROMs and sixteen 128K ROMs)</p> <table data-bbox="535 1165 1250 1459"> <thead> <tr> <th>A6W1</th> <th>POSITION 1</th> <th>A6W2</th> <th>POSITION 1</th> </tr> </thead> <tbody> <tr><td>A6W3-1</td><td>ON</td><td>A6W4-1</td><td>ON</td></tr> <tr><td>A6W3-2</td><td>OFF</td><td>A6W4-2</td><td>OFF</td></tr> <tr><td>A6W3-3</td><td>ON</td><td>A6W4-3</td><td>ON</td></tr> <tr><td>A6W3-4</td><td>OFF</td><td>A6W4-4</td><td>OFF</td></tr> <tr><td>A6W3-5</td><td>ON</td><td>A6W4-5</td><td>ON</td></tr> <tr><td>A6W3-6</td><td>OFF</td><td>A6W4-6</td><td>OFF</td></tr> <tr><td>A6W3-7</td><td>ON</td><td>A6W4-7</td><td>ON</td></tr> <tr><td>A6W3-8</td><td>OFF</td><td>A6W4-8</td><td>OFF</td></tr> </tbody> </table> <p>Configuration 2 (sixteen 256K ROMs)</p> <table data-bbox="535 1543 1153 1837"> <thead> <tr> <th>A6W1</th> <th>POSITION 2</th> <th>A6W2</th> <th>-</th> </tr> </thead> <tbody> <tr><td>A6W3-1</td><td>-</td><td>A6W4-1</td><td>OFF</td></tr> <tr><td>A6W3-2</td><td>-</td><td>A6W4-2</td><td>ON</td></tr> <tr><td>A6W3-3</td><td>-</td><td>A6W4-3</td><td>OFF</td></tr> <tr><td>A6W3-4</td><td>-</td><td>A6W4-4</td><td>ON</td></tr> <tr><td>A6W3-5</td><td>-</td><td>A6W4-5</td><td>OFF</td></tr> <tr><td>A6W3-6</td><td>-</td><td>A6W4-6</td><td>ON</td></tr> <tr><td>A6W3-7</td><td>-</td><td>A6W4-7</td><td>OFF</td></tr> <tr><td>A6W3-8</td><td>-</td><td>A6W4-8</td><td>ON</td></tr> </tbody> </table> <p>- : setting unimportant</p>	A6W1	POSITION 1	A6W2	POSITION 1	A6W3-1	ON	A6W4-1	ON	A6W3-2	OFF	A6W4-2	OFF	A6W3-3	ON	A6W4-3	ON	A6W3-4	OFF	A6W4-4	OFF	A6W3-5	ON	A6W4-5	ON	A6W3-6	OFF	A6W4-6	OFF	A6W3-7	ON	A6W4-7	ON	A6W3-8	OFF	A6W4-8	OFF	A6W1	POSITION 2	A6W2	-	A6W3-1	-	A6W4-1	OFF	A6W3-2	-	A6W4-2	ON	A6W3-3	-	A6W4-3	OFF	A6W3-4	-	A6W4-4	ON	A6W3-5	-	A6W4-5	OFF	A6W3-6	-	A6W4-6	ON	A6W3-7	-	A6W4-7	OFF	A6W3-8	-	A6W4-8	ON
A6W1	POSITION 1	A6W2	POSITION 1																																																																						
A6W3-1	ON	A6W4-1	ON																																																																						
A6W3-2	OFF	A6W4-2	OFF																																																																						
A6W3-3	ON	A6W4-3	ON																																																																						
A6W3-4	OFF	A6W4-4	OFF																																																																						
A6W3-5	ON	A6W4-5	ON																																																																						
A6W3-6	OFF	A6W4-6	OFF																																																																						
A6W3-7	ON	A6W4-7	ON																																																																						
A6W3-8	OFF	A6W4-8	OFF																																																																						
A6W1	POSITION 2	A6W2	-																																																																						
A6W3-1	-	A6W4-1	OFF																																																																						
A6W3-2	-	A6W4-2	ON																																																																						
A6W3-3	-	A6W4-3	OFF																																																																						
A6W3-4	-	A6W4-4	ON																																																																						
A6W3-5	-	A6W4-5	OFF																																																																						
A6W3-6	-	A6W4-6	ON																																																																						
A6W3-7	-	A6W4-7	OFF																																																																						
A6W3-8	-	A6W4-8	ON																																																																						

Table A6-1. A6 Troubleshooting Aids (3 of 3)

Reference Designator	Use																																							
A6W3, A6W4 (continued)	Configuration 3 (sixteen 256K ROMs and eight 128K ROMs)																																							
	<table border="0"> <tr> <td>A6W1</td> <td>POSITION 2</td> <td>A6W2</td> <td>POSITION 1</td> </tr> <tr> <td>A6W3-1</td> <td>OFF</td> <td>A6W4-1</td> <td>OFF</td> </tr> <tr> <td>A6W3-2</td> <td>ON</td> <td>A6W4-2</td> <td>ON</td> </tr> <tr> <td>A6W3-3</td> <td>ON</td> <td>A6W4-3</td> <td>OFF</td> </tr> <tr> <td>A6W3-4</td> <td>OFF</td> <td>A6W4-4</td> <td>ON</td> </tr> <tr> <td>A6W3-5</td> <td>ON</td> <td>A6W4-5</td> <td>OFF</td> </tr> <tr> <td>A6W3-6</td> <td>OFF</td> <td>A6W4-6</td> <td>ON</td> </tr> <tr> <td>A6W3-7</td> <td>OFF</td> <td>A6W4-7</td> <td>OFF</td> </tr> <tr> <td>A6W3-8</td> <td>ON</td> <td>A6W4-8</td> <td>ON</td> </tr> </table>	A6W1	POSITION 2	A6W2	POSITION 1	A6W3-1	OFF	A6W4-1	OFF	A6W3-2	ON	A6W4-2	ON	A6W3-3	ON	A6W4-3	OFF	A6W3-4	OFF	A6W4-4	ON	A6W3-5	ON	A6W4-5	OFF	A6W3-6	OFF	A6W4-6	ON	A6W3-7	OFF	A6W4-7	OFF	A6W3-8	ON	A6W4-8	ON			
A6W1	POSITION 2	A6W2	POSITION 1																																					
A6W3-1	OFF	A6W4-1	OFF																																					
A6W3-2	ON	A6W4-2	ON																																					
A6W3-3	ON	A6W4-3	OFF																																					
A6W3-4	OFF	A6W4-4	ON																																					
A6W3-5	ON	A6W4-5	OFF																																					
A6W3-6	OFF	A6W4-6	ON																																					
A6W3-7	OFF	A6W4-7	OFF																																					
A6W3-8	ON	A6W4-8	ON																																					
	Configuration 4 (twenty-four 256K ROMs)																																							
	<table border="0"> <tr> <td>A6W1</td> <td>POSITION 2</td> <td>A6W2</td> <td>POSITION 2</td> </tr> <tr> <td>A6W3-1</td> <td>OFF</td> <td>A6W4-1</td> <td>OFF</td> </tr> <tr> <td>A6W3-2</td> <td>ON</td> <td>A6W4-2</td> <td>ON</td> </tr> <tr> <td>A6W3-3</td> <td>OFF</td> <td>A6W4-3</td> <td>OFF</td> </tr> <tr> <td>A6W3-4</td> <td>ON</td> <td>A6W4-4</td> <td>ON</td> </tr> <tr> <td>A6W3-5</td> <td>OFF</td> <td>A6W4-5</td> <td>OFF</td> </tr> <tr> <td>A6W3-6</td> <td>ON</td> <td>A6W4-6</td> <td>ON</td> </tr> <tr> <td>A6W3-7</td> <td>OFF</td> <td>A6W4-7</td> <td>OFF</td> </tr> <tr> <td>A6W3-8</td> <td>ON</td> <td>A6W4-8</td> <td>ON</td> </tr> </table>	A6W1	POSITION 2	A6W2	POSITION 2	A6W3-1	OFF	A6W4-1	OFF	A6W3-2	ON	A6W4-2	ON	A6W3-3	OFF	A6W4-3	OFF	A6W3-4	ON	A6W4-4	ON	A6W3-5	OFF	A6W4-5	OFF	A6W3-6	ON	A6W4-6	ON	A6W3-7	OFF	A6W4-7	OFF	A6W3-8	ON	A6W4-8	ON			
A6W1	POSITION 2	A6W2	POSITION 2																																					
A6W3-1	OFF	A6W4-1	OFF																																					
A6W3-2	ON	A6W4-2	ON																																					
A6W3-3	OFF	A6W4-3	OFF																																					
A6W3-4	ON	A6W4-4	ON																																					
A6W3-5	OFF	A6W4-5	OFF																																					
A6W3-6	ON	A6W4-6	ON																																					
A6W3-7	OFF	A6W4-7	OFF																																					
A6W3-8	ON	A6W4-8	ON																																					
A6W5, A6W6	Normally set to Position 1. W5 and W6 enable the local clock generator which supplies the clock used for testing the digital boards when the 20MHz clock from the A10 board is missing.																																							

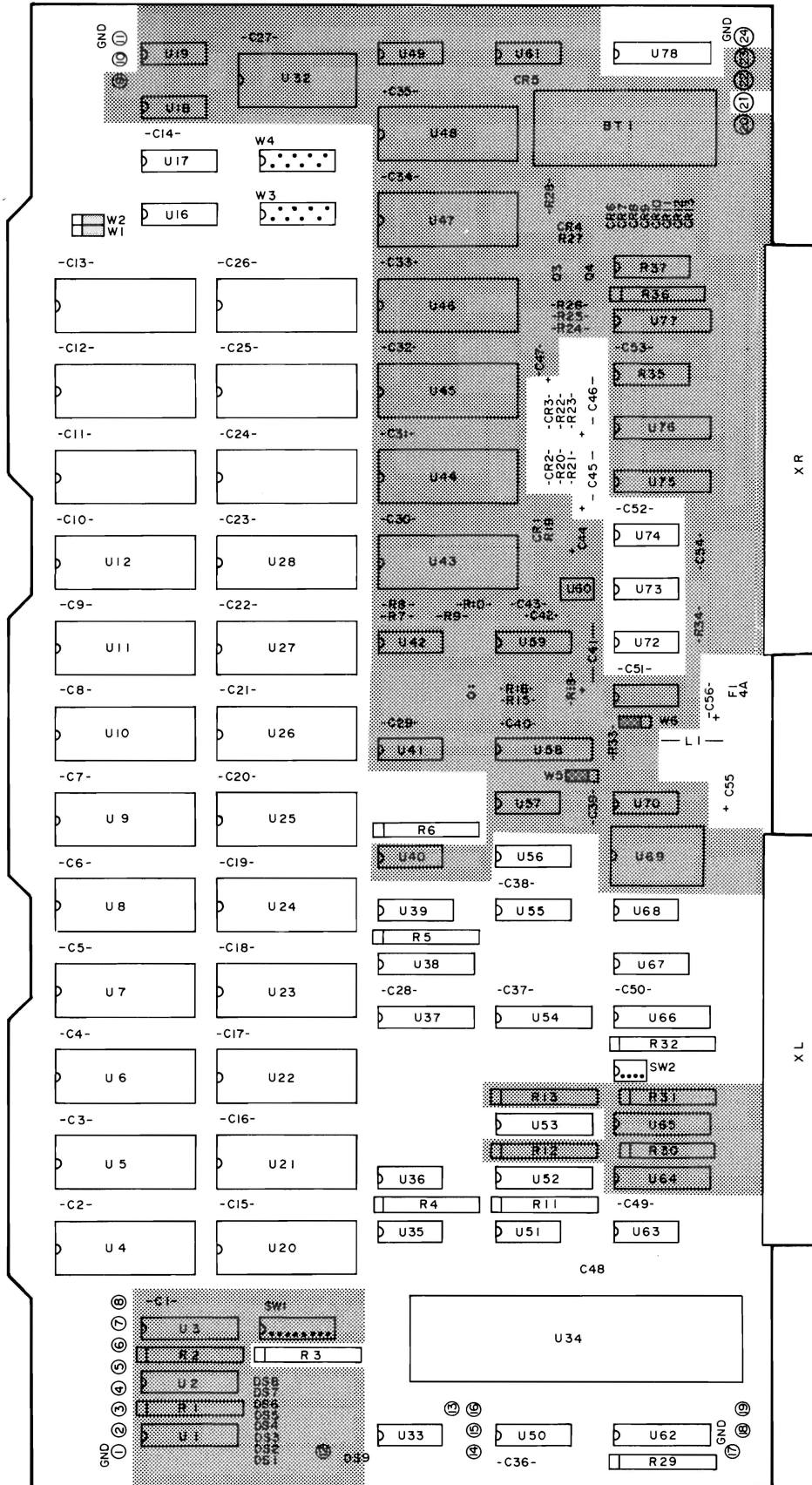

A6 Data Manipulation Processor Component Locations (1 of 2)

A6 DATA MANIPULATION PROCESSOR 1 of 2

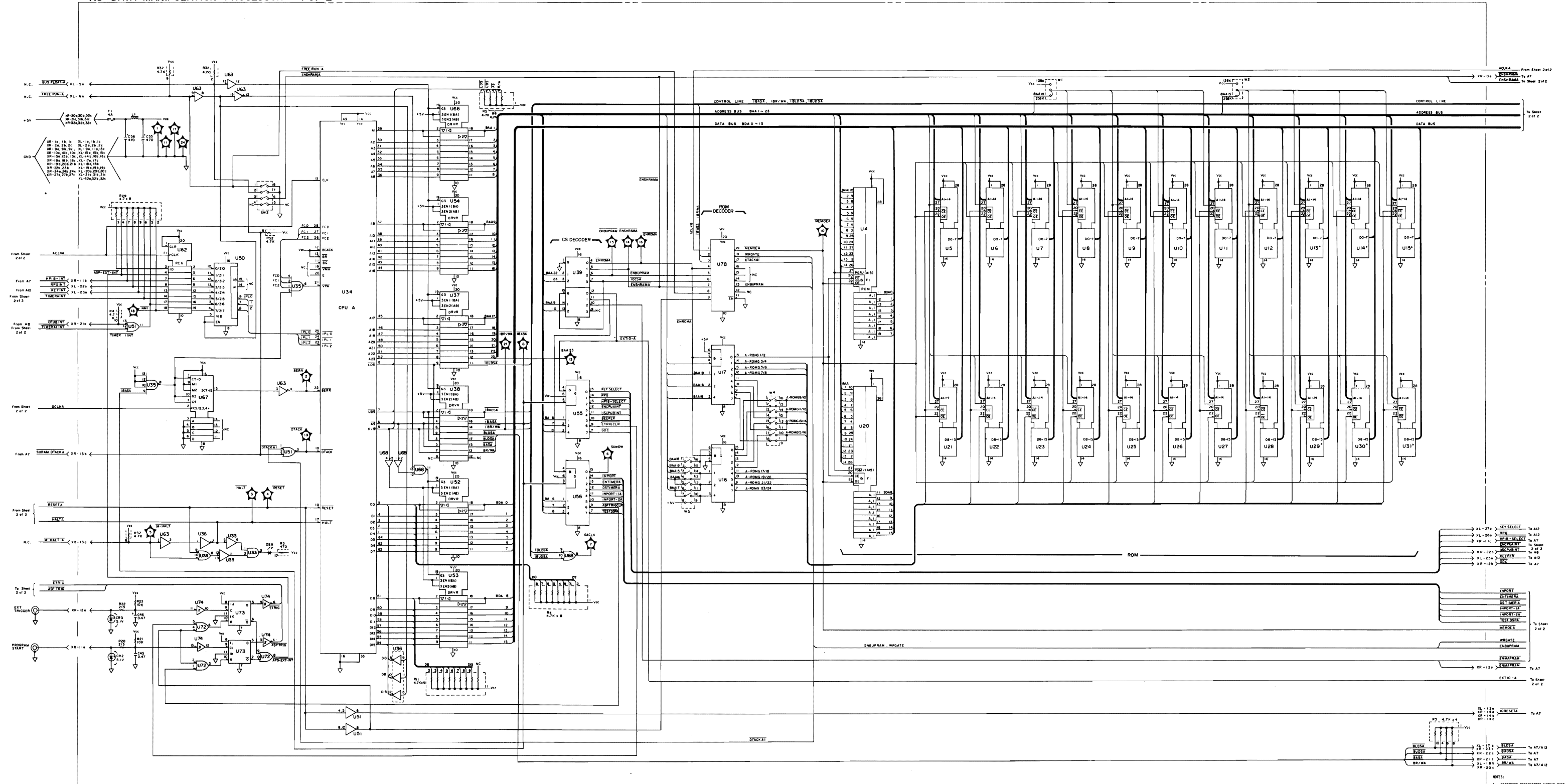

U13, U14, U15, U20, U30 and U31 are not included.

- NOTES:
- REFERENCE DESIGNATORS WITHIN THIS ASSEMBLY ARE ABREVIATED. PREFIX ABREVIATION WITH ASSUMED NUMBER FOR COMPLETE REFERENCE DESIGNATOR.
 - UNLESS OTHERWISE INDICATED: RESISTANCE IN OHMS (Ω), CAPACITANCE IN MICROFARADS (μF), INDUCTANCE IN MICROHENRIES (μH).

A6 Data Manipulation Processor Schematic Diagram (1 of 2)

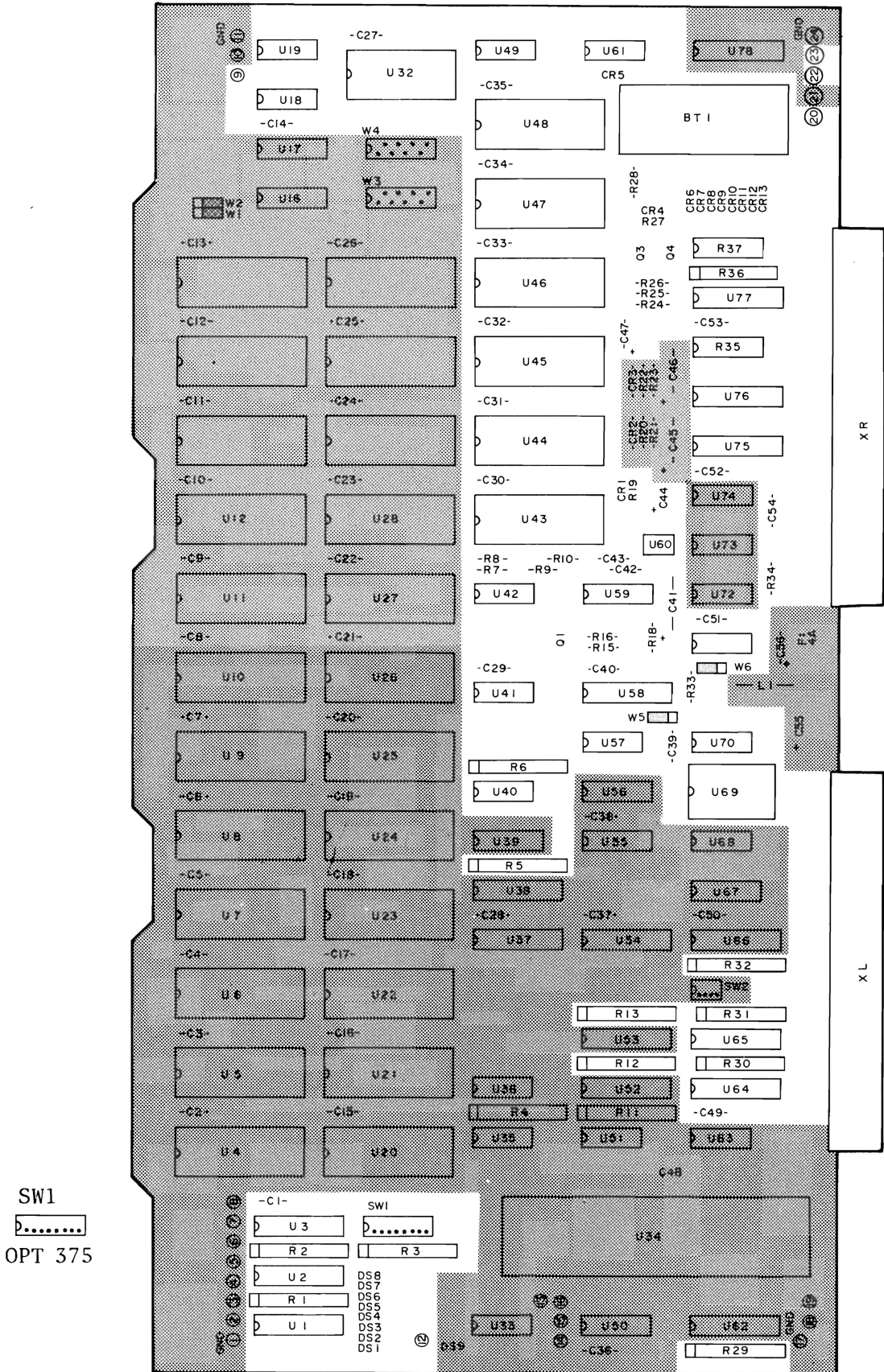

A6 Data Manipulation Processor Component Locations (2 of 2)

A6 DATA MANIPULATION PROCESSOR 2 of 2

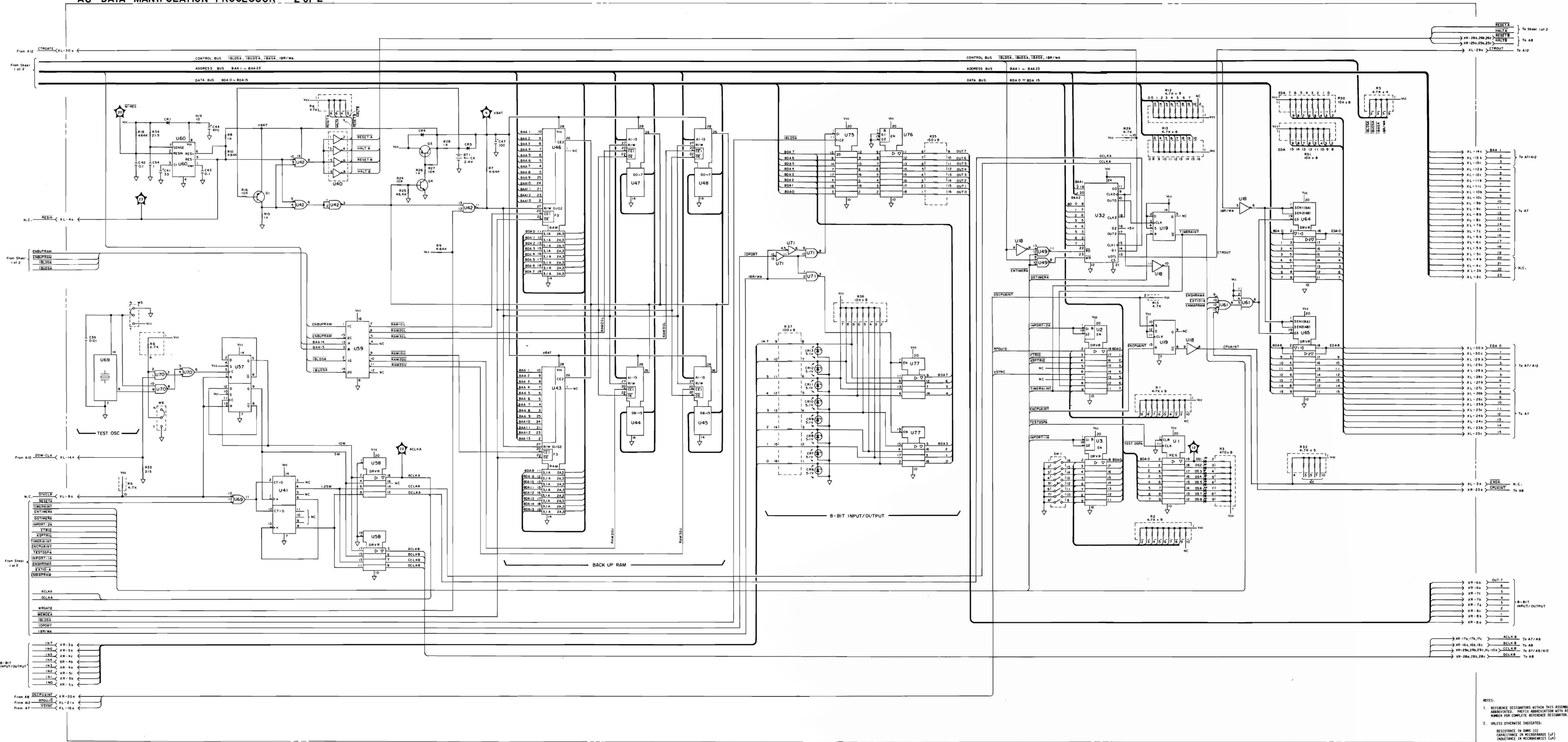

NOTES:
 1. REFERENCE DESIGNATORS WITHIN THIS ASSEMBLY ARE ABBREVIATED: REF#1 ABBREVIATION WITH ASSEMBLY NUMBER FOR COMPLETE REFERENCE DESIGNATOR.
 2. UNLESS OTHERWISE INDICATED:
 RESISTANCE IN OHMS (Ω)
 CAPACITANCE IN MICROFARADS (μF)
 INDUCTANCE IN MICRONEHMS (μH)

*SW1 - 5 (BIT 4)
 OFF: OPTION 350
 ON: OPTION 375

A6 Data Manipulation Processor Schematic Diagram (2 of 2)

A7 GDC/RAM Service Sheet

The A7 board contains the Shared RAM, HP-IB interface, Graphics Display Controller, and video RAM. The Shared RAM is connected to the address, data, and control buses of CPU A and CPU B, and the A7 board arbitrates the bus usage between the CPUs. The bus arbitrator in the shared RAM block controls the timing of CPU A and CPU B so that CPU A and CPU B are not simultaneously accessing the busses. The GDC supplies the control signals to the CRT section, displays the contents of the video RAM, and writes data to the video RAM.

SHARED RAM	A7U1 to A7U5, A7U21 to A7U28, A7U46 to A7U53, and A7U69 to A7U73
BUS ARBITRATOR	A7U77
GDC	A7U29
V RAM 0	A7U34, A7U35, A7U57, A7U58, A7U80, A7U81, A7U105, and A7U106
V RAM 1	A7U36, A7U37, A7U59, A7U60, A7U82, A7U83, A7U107, and A7U108
V RAM 2	A7U38, A7U39, A7U61, A7U62, A7U84, A7U85, A7U109, and A7U110
V RAM 3	A7U40, A7U41, A7U63, A7U64, A7U86, A7U87, A7U111, and A7U112
V RAM 4	A7U42, A7U43, A7U65, A7U66, A7U88, A7U89, A7U113, and A7U114
HP-IB chip	A7U115

Figure A7-1 is a block diagram of the Shared RAM Section. The Address, data, and control busses of CPU A and CPU B are input through three state buffers, and access by CPU A or CPU B is determined by the BUS ARBITRATOR. The BUS ARBITRATOR receives the chip select signals from the CPUs and outputs an enable signal. The right to access memory is granted to the CPU whose chip select signal arrives first. For example, in the timing sequence shown in Figure A7-2, CPU A accesses shared RAM while CPU B waits. CPU B waits to access memory until one instruction cycle of CPU A has passed (no.1). Similarly, if CPU B is accessing shared RAM and CPU A requires access also, CPU A waits for one instruction cycle of CPU B (no.2).

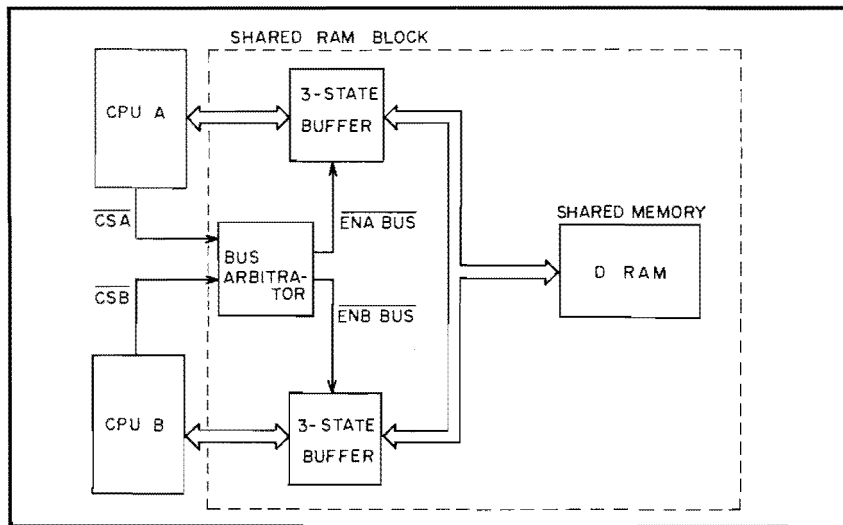

Figure A7-1. Shared RAM Block Diagram

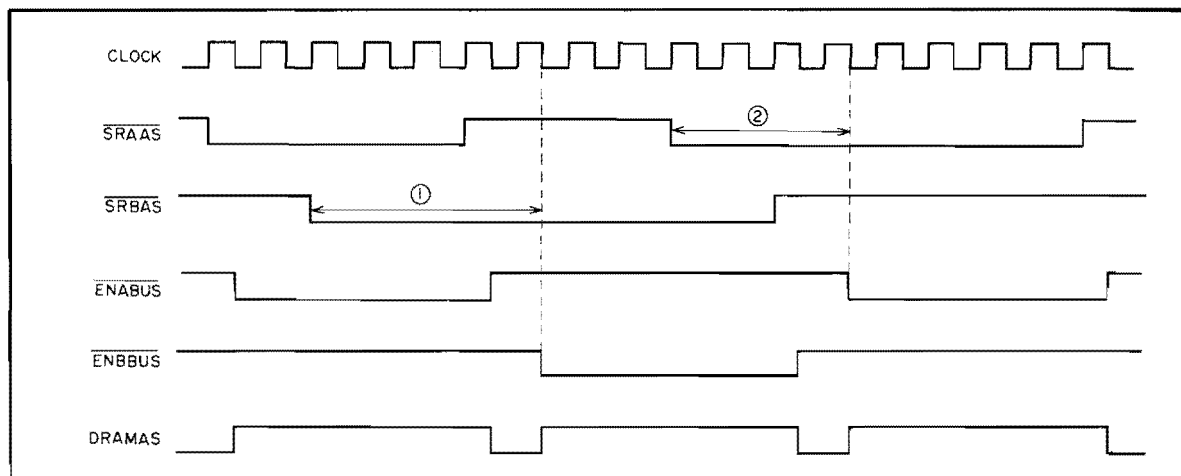

Figure A7-2. Shared RAM Timing Chart

The GDC section of the A7 board outputs the CRT sync signals (Hsync, Vsync). The GDC specifies the address from which the 16 bit output data is taken from the video RAM, and converts the parallel data to serial data (5-bit code). Color information is added by the COLOR MAP RAM, converting the signal from 5 bits to 6 bits (RGB signal), and is output to the CRT section.

When the graphics display is triggered by Hsync, the GDC writes to video RAM. Video RAM consists of five sections, trace A data is stored in video RAM 0, trace B data is stored in video RAM 1, and the data for other traces, graticule, etc. are stored in video RAMs 3 to 5.

Table A7-1. A7 Troubleshooting Aids

Reference Designator	Use
A7W1	Normally set to POSITION 1. Position 2 of W1 is used for the REFRESH COUNTER TEST, causing A7U75 to output a series of REFRESH CYCLES.
A7W2	W2's position is determined by the type of DRAM being used. POSITION 1: 64Kbit DRAM (Version 2.0/2.1) POSITION 2: 256Kbit DRAM (Version 2.2)
A7W3	Set to POSITION 1. Position 2 of W3 is used to synchronize the interval of the REFRESH signal during the digital board test.

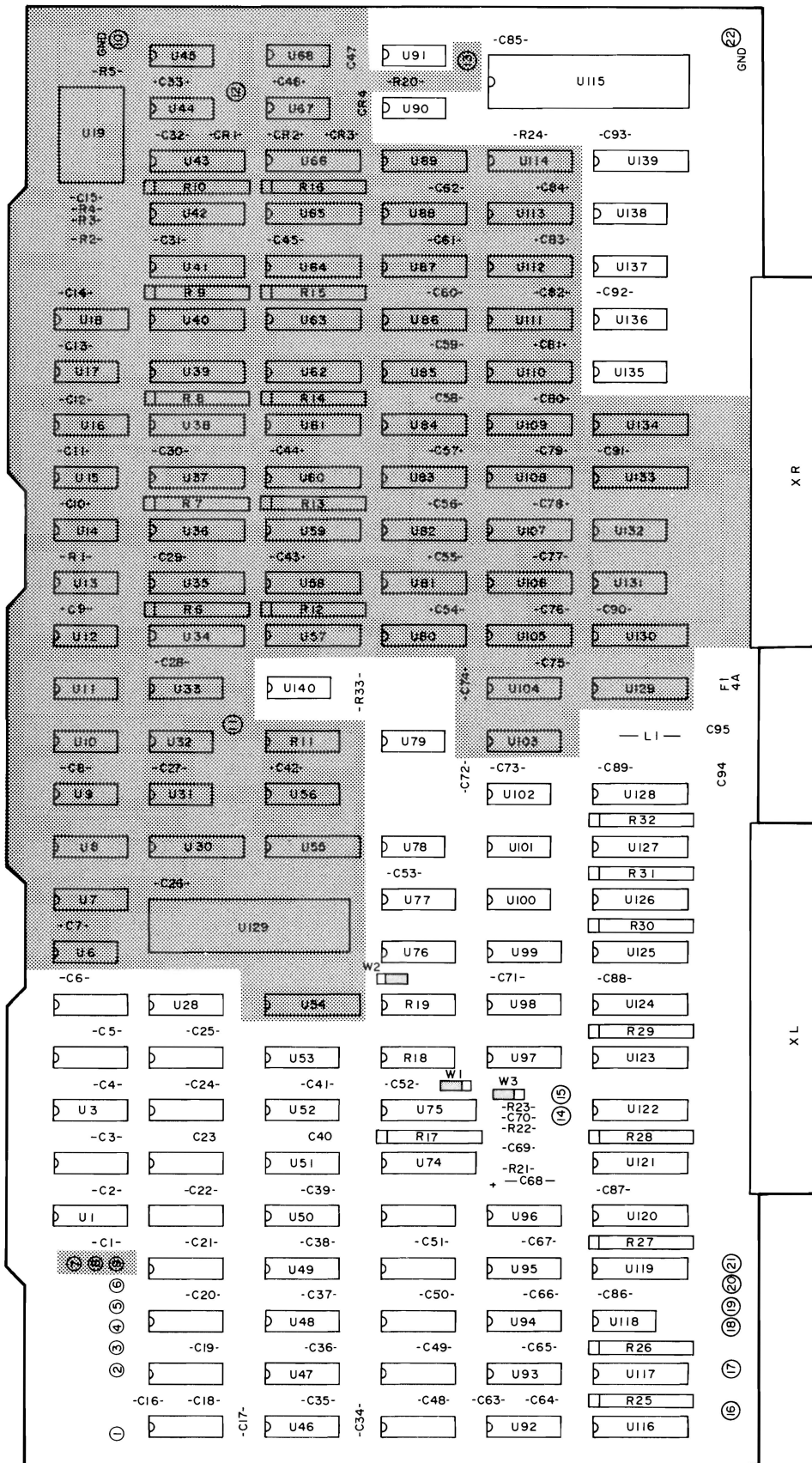

A7 GDC/RAM Component Locations (1 of 2)

A7 GDC/RAM 1 of 2

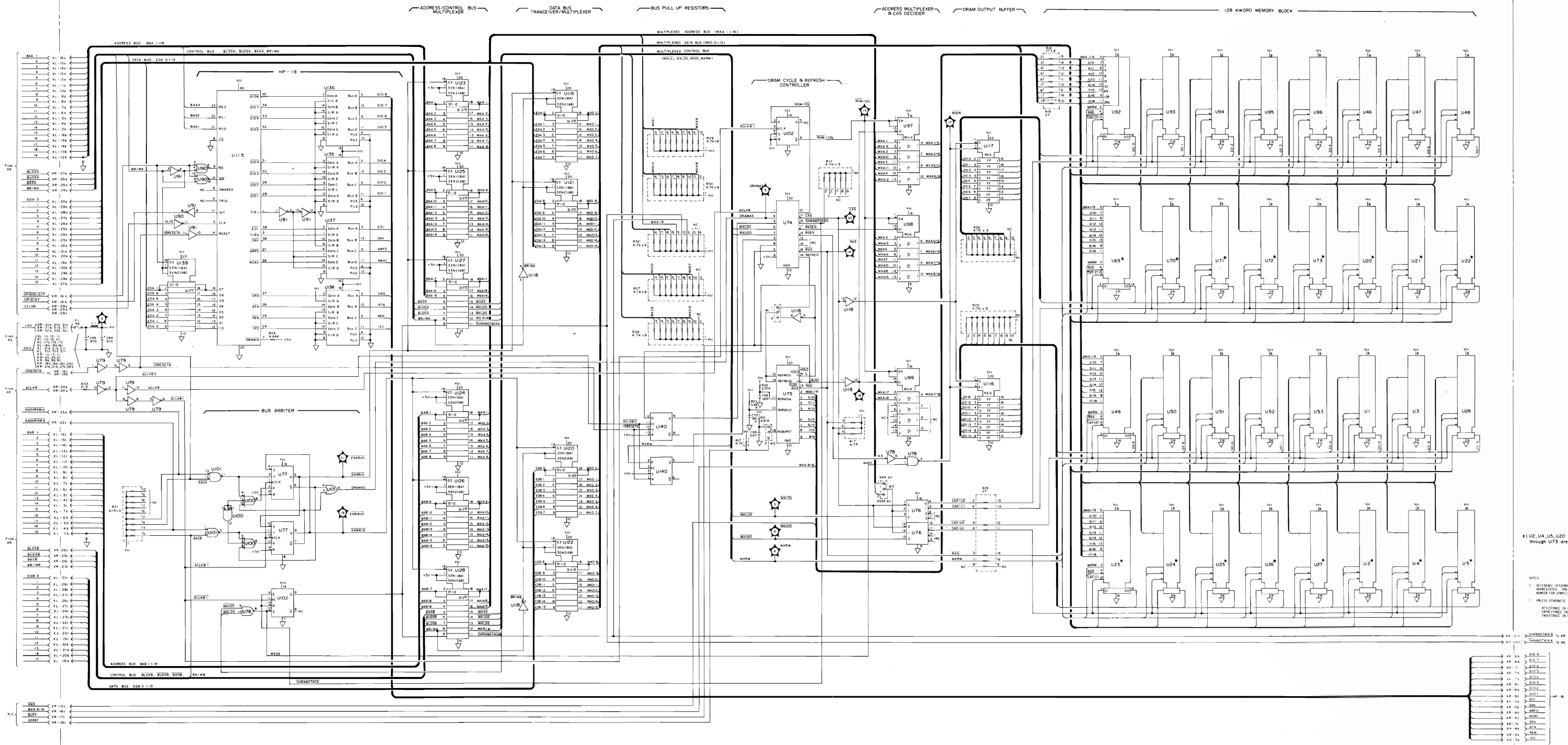

NOTES:
 1. REFERENCE DESIGNATORS WITHIN THIS ASSEMBLY SHIP INDICATED. PREFIX INDICATES WITHIN ASSEMBLY NUMBER FOR COMPLETE REFERENCE DESIGNATION.
 2. UNLESS OTHERWISE INDICATED:
 RESISTANCE IN OHMS ()
 CAPACITANCE IN MICROFARADS (UF)
 INDICATED IN MICROFARADS (UF)

BAR 1	KL 184	BAR 19	KL 198
BAR 2	KL 185	BAR 20	KL 199
BAR 3	KL 186	BAR 21	KL 200
BAR 4	KL 187	BAR 22	KL 201
BAR 5	KL 188	BAR 23	KL 202
BAR 6	KL 189	BAR 24	KL 203
BAR 7	KL 190	BAR 25	KL 204
BAR 8	KL 191	BAR 26	KL 205
BAR 9	KL 192	BAR 27	KL 206
BAR 10	KL 193	BAR 28	KL 207
BAR 11	KL 194	BAR 29	KL 208
BAR 12	KL 195	BAR 30	KL 209
BAR 13	KL 196	BAR 31	KL 210
BAR 14	KL 197	BAR 32	KL 211
BAR 15	KL 198	BAR 33	KL 212
BAR 16	KL 199	BAR 34	KL 213
BAR 17	KL 200	BAR 35	KL 214
BAR 18	KL 201	BAR 36	KL 215
BAR 19	KL 202	BAR 37	KL 216
BAR 20	KL 203	BAR 38	KL 217
BAR 21	KL 204	BAR 39	KL 218
BAR 22	KL 205	BAR 40	KL 219
BAR 23	KL 206	BAR 41	KL 220
BAR 24	KL 207	BAR 42	KL 221
BAR 25	KL 208	BAR 43	KL 222
BAR 26	KL 209	BAR 44	KL 223
BAR 27	KL 210	BAR 45	KL 224
BAR 28	KL 211	BAR 46	KL 225
BAR 29	KL 212	BAR 47	KL 226
BAR 30	KL 213	BAR 48	KL 227
BAR 31	KL 214	BAR 49	KL 228
BAR 32	KL 215	BAR 50	KL 229
BAR 33	KL 216	BAR 51	KL 230
BAR 34	KL 217	BAR 52	KL 231
BAR 35	KL 218	BAR 53	KL 232
BAR 36	KL 219	BAR 54	KL 233
BAR 37	KL 220	BAR 55	KL 234
BAR 38	KL 221	BAR 56	KL 235
BAR 39	KL 222	BAR 57	KL 236
BAR 40	KL 223	BAR 58	KL 237
BAR 41	KL 224	BAR 59	KL 238
BAR 42	KL 225	BAR 60	KL 239
BAR 43	KL 226	BAR 61	KL 240
BAR 44	KL 227	BAR 62	KL 241
BAR 45	KL 228	BAR 63	KL 242
BAR 46	KL 229	BAR 64	KL 243
BAR 47	KL 230	BAR 65	KL 244
BAR 48	KL 231	BAR 66	KL 245
BAR 49	KL 232	BAR 67	KL 246
BAR 50	KL 233	BAR 68	KL 247
BAR 51	KL 234	BAR 69	KL 248
BAR 52	KL 235	BAR 70	KL 249
BAR 53	KL 236	BAR 71	KL 250
BAR 54	KL 237	BAR 72	KL 251
BAR 55	KL 238	BAR 73	KL 252
BAR 56	KL 239	BAR 74	KL 253
BAR 57	KL 240	BAR 75	KL 254
BAR 58	KL 241	BAR 76	KL 255
BAR 59	KL 242	BAR 77	KL 256
BAR 60	KL 243	BAR 78	KL 257
BAR 61	KL 244	BAR 79	KL 258
BAR 62	KL 245	BAR 80	KL 259
BAR 63	KL 246	BAR 81	KL 260
BAR 64	KL 247	BAR 82	KL 261
BAR 65	KL 248	BAR 83	KL 262
BAR 66	KL 249	BAR 84	KL 263
BAR 67	KL 250	BAR 85	KL 264
BAR 68	KL 251	BAR 86	KL 265
BAR 69	KL 252	BAR 87	KL 266
BAR 70	KL 253	BAR 88	KL 267
BAR 71	KL 254	BAR 89	KL 268
BAR 72	KL 255	BAR 90	KL 269
BAR 73	KL 256	BAR 91	KL 270
BAR 74	KL 257	BAR 92	KL 271
BAR 75	KL 258	BAR 93	KL 272
BAR 76	KL 259	BAR 94	KL 273
BAR 77	KL 260	BAR 95	KL 274
BAR 78	KL 261	BAR 96	KL 275
BAR 79	KL 262	BAR 97	KL 276
BAR 80	KL 263	BAR 98	KL 277
BAR 81	KL 264	BAR 99	KL 278
BAR 82	KL 265	BAR 100	KL 279
BAR 83	KL 266	BAR 101	KL 280
BAR 84	KL 267	BAR 102	KL 281
BAR 85	KL 268	BAR 103	KL 282
BAR 86	KL 269	BAR 104	KL 283
BAR 87	KL 270	BAR 105	KL 284
BAR 88	KL 271	BAR 106	KL 285
BAR 89	KL 272	BAR 107	KL 286
BAR 90	KL 273	BAR 108	KL 287
BAR 91	KL 274	BAR 109	KL 288
BAR 92	KL 275	BAR 110	KL 289
BAR 93	KL 276	BAR 111	KL 290
BAR 94	KL 277	BAR 112	KL 291
BAR 95	KL 278	BAR 113	KL 292
BAR 96	KL 279	BAR 114	KL 293
BAR 97	KL 280	BAR 115	KL 294
BAR 98	KL 281	BAR 116	KL 295
BAR 99	KL 282	BAR 117	KL 296
BAR 100	KL 283	BAR 118	KL 297
BAR 101	KL 284	BAR 119	KL 298
BAR 102	KL 285	BAR 120	KL 299
BAR 103	KL 286	BAR 121	KL 300
BAR 104	KL 287	BAR 122	KL 301
BAR 105	KL 288	BAR 123	KL 302
BAR 106	KL 289	BAR 124	KL 303
BAR 107	KL 290	BAR 125	KL 304
BAR 108	KL 291	BAR 126	KL 305
BAR 109	KL 292	BAR 127	KL 306
BAR 110	KL 293	BAR 128	KL 307
BAR 111	KL 294	BAR 129	KL 308
BAR 112	KL 295	BAR 130	KL 309
BAR 113	KL 296	BAR 131	KL 310
BAR 114	KL 297	BAR 132	KL 311
BAR 115	KL 298	BAR 133	KL 312
BAR 116	KL 299	BAR 134	KL 313
BAR 117	KL 300	BAR 135	KL 314
BAR 118	KL 301	BAR 136	KL 315
BAR 119	KL 302	BAR 137	KL 316
BAR 120	KL 303	BAR 138	KL 317
BAR 121	KL 304	BAR 139	KL 318
BAR 122	KL 305	BAR 140	KL 319
BAR 123	KL 306	BAR 141	KL 320
BAR 124	KL 307	BAR 142	KL 321
BAR 125	KL 308	BAR 143	KL 322
BAR 126	KL 309	BAR 144	KL 323
BAR 127	KL 310	BAR 145	KL 324
BAR 128	KL 311	BAR 146	KL 325
BAR 129	KL 312	BAR 147	KL 326
BAR 130	KL 313	BAR 148	KL 327
BAR 131	KL 314	BAR 149	KL 328
BAR 132	KL 315	BAR 150	KL 329
BAR 133	KL 316	BAR 151	KL 330
BAR 134	KL 317	BAR 152	KL 331
BAR 135	KL 318	BAR 153	KL 332
BAR 136	KL 319	BAR 154	KL 333
BAR 137	KL 320	BAR 155	KL 334
BAR 138	KL 321	BAR 156	KL 335
BAR 139	KL 322	BAR 157	KL 336
BAR 140	KL 323	BAR 158	KL 337
BAR 141	KL 324	BAR 159	KL 338
BAR 142	KL 325	BAR 160	KL 339
BAR 143	KL 326	BAR 161	KL 340
BAR 144	KL 327	BAR 162	KL 341
BAR 145	KL 328	BAR 163	KL 342
BAR 146	KL 329	BAR 164	KL 343
BAR 147	KL 330	BAR 165	KL 344
BAR 148	KL 331	BAR 166	KL 345
BAR 149	KL 332	BAR 167	KL 346
BAR 150	KL 333	BAR 168	KL 347
BAR 151	KL 334	BAR 169	KL 348
BAR 152	KL 335	BAR 170	KL 349
BAR 153	KL 336	BAR 171	KL 350
BAR 154	KL 337	BAR 172	KL 351
BAR 155	KL 338	BAR 173	KL 352
BAR 156	KL 339	BAR 174	KL 353
BAR 157	KL 340	BAR 175	KL 354
BAR 158	KL 341	BAR 176	KL 355
BAR 159	KL 342	BAR 177	KL 356
BAR 160	KL 343	BAR 178	KL 357
BAR 161	KL 344	BAR 179	KL 358
BAR 162	KL 345	BAR 180	KL 359
BAR 163	KL 346	BAR 181	KL 360
BAR 164	KL 347	BAR 182	KL 361
BAR 165	KL 348	BAR 183	KL 362
BAR 166	KL 349	BAR 184	KL 363
BAR 167	KL 350	BAR 185	KL 364
BAR 168	KL 351	BAR 186	KL 365
BAR 169	KL 352	BAR 187	KL 366
BAR 170	KL 353	BAR 188	KL 367
BAR 171	KL 354	BAR 189	KL 368
BAR 172	KL 355	BAR 190	KL 369
BAR 173	KL 356	BAR 191	KL 370
BAR 174	KL 357	BAR 192	KL 371
BAR 175	KL 358	BAR 193	KL 372
BAR 176	KL 359	BAR 194	KL 373
BAR 177	KL 360	BAR 195	KL 374
BAR 178	KL 361	BAR 196	KL 375
BAR 179	KL 362	BAR 197	KL 376
BAR 180	KL 363	BAR 198	KL 377
BAR 181	KL 364	BAR 199	KL 378
BAR 182	KL 365	BAR 200	KL 379
BAR 183	KL 366	BAR 201	KL 380
BAR 184	KL 367	BAR 202	KL 381
BAR 185	KL 368	BAR 203	KL 382
BAR 186	KL 369	BAR 204	KL 383
BAR 187	KL 370	BAR 205	KL 384
BAR 188	KL 371	BAR 206	KL 385
BAR 189	KL 372	BAR 207	KL 386
BAR 190	KL 373	BAR 208	KL 387
BAR 191	KL 374	BAR 209	KL 388
BAR 192	KL 375	BAR 210	KL 389
BAR 193	KL 376	BAR 211	KL 390
BAR 194	KL 377	BAR 212	KL 391
BAR 195	KL 378	BAR 213	KL 392
BAR 196	KL 379	BAR 214	KL 393
BAR 197	KL 380	BAR 215	KL 394
BAR 198	KL 381	BAR 216	KL 395
BAR 199	KL 382	BAR 217	KL 396
BAR 200	KL 383	BAR 218	KL 397
BAR 201	KL 384	BAR 219	KL 398
BAR 202	KL 385	BAR 220	KL 399
BAR 203	KL 386	BAR 221	KL 400
BAR 204	KL 387	BAR 222	KL 401
BAR 205	KL 388	BAR 223	KL 402
BAR 206	KL 389	BAR 224	KL 403
BAR 207	KL 390	BAR 225	KL 404
BAR 208	KL 391	BAR 226	KL 405
BAR 209	KL 392	BAR 227	KL 406
BAR 210	KL 393	BAR 228	KL 407
BAR 211	KL 394	BAR 229	KL 408
BAR 212	KL 395	BAR 230	KL 409
BAR 213	KL 396	BAR 231	KL 410
BAR 214	KL 397	BAR 232	KL 411
BAR 215	KL 398	BAR 233	KL 412
BAR 216	KL 399	BAR 234	KL 413
BAR 217	KL 400	BAR 235	KL 414
BAR 218	KL 401	BAR 236	KL 415
BAR 219	KL 402	BAR 237	KL 416
BAR 220	KL 403	BAR 238	KL 417
BAR 221	KL 404	BAR 239	KL 418
BAR 222	KL 405	BAR 240	KL 419
BAR 223	KL 406	BAR 241	KL 420
BAR 224	KL 407	BAR 242	KL 421
BAR 225	KL 408	BAR 243	KL 422
BAR 226	KL 409	BAR 244	KL 423
BAR 227	KL 410	BAR 245	KL 424
BAR 228	KL 411	BAR 246	KL 425
BAR 229	KL 412	BAR 247	KL 426
BAR 230	KL 413	BAR 248	KL 427
BAR 231	KL 414	BAR 249	KL 428
BAR 232	KL 415	BAR 250	KL 429
BAR 233	KL 416	BAR 251	KL 430
BAR 234	KL 417	BAR 252	KL 431

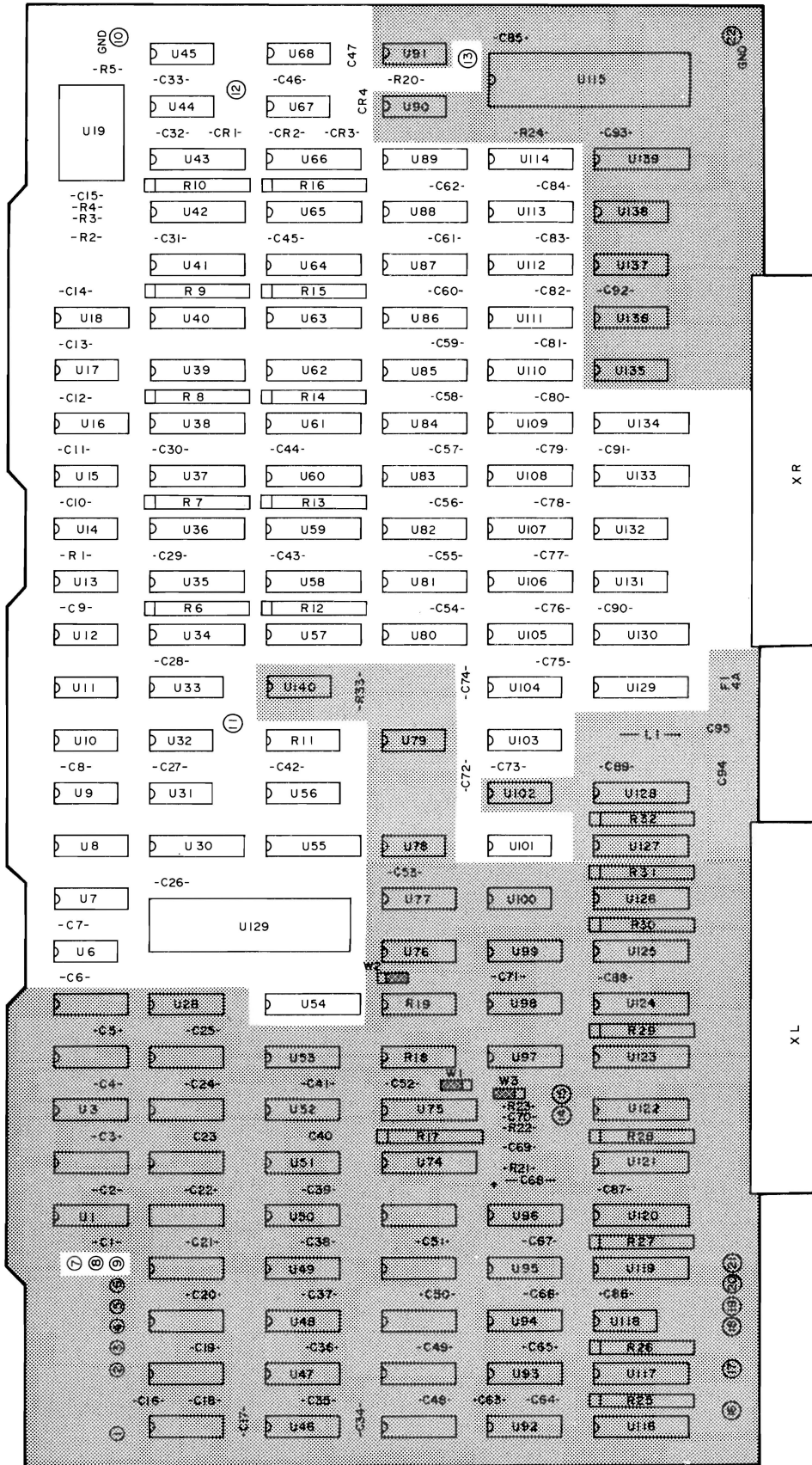

A7 GDC/RAM Component Locations (2 of 2)

A7 GDC / RAM 2 of 2

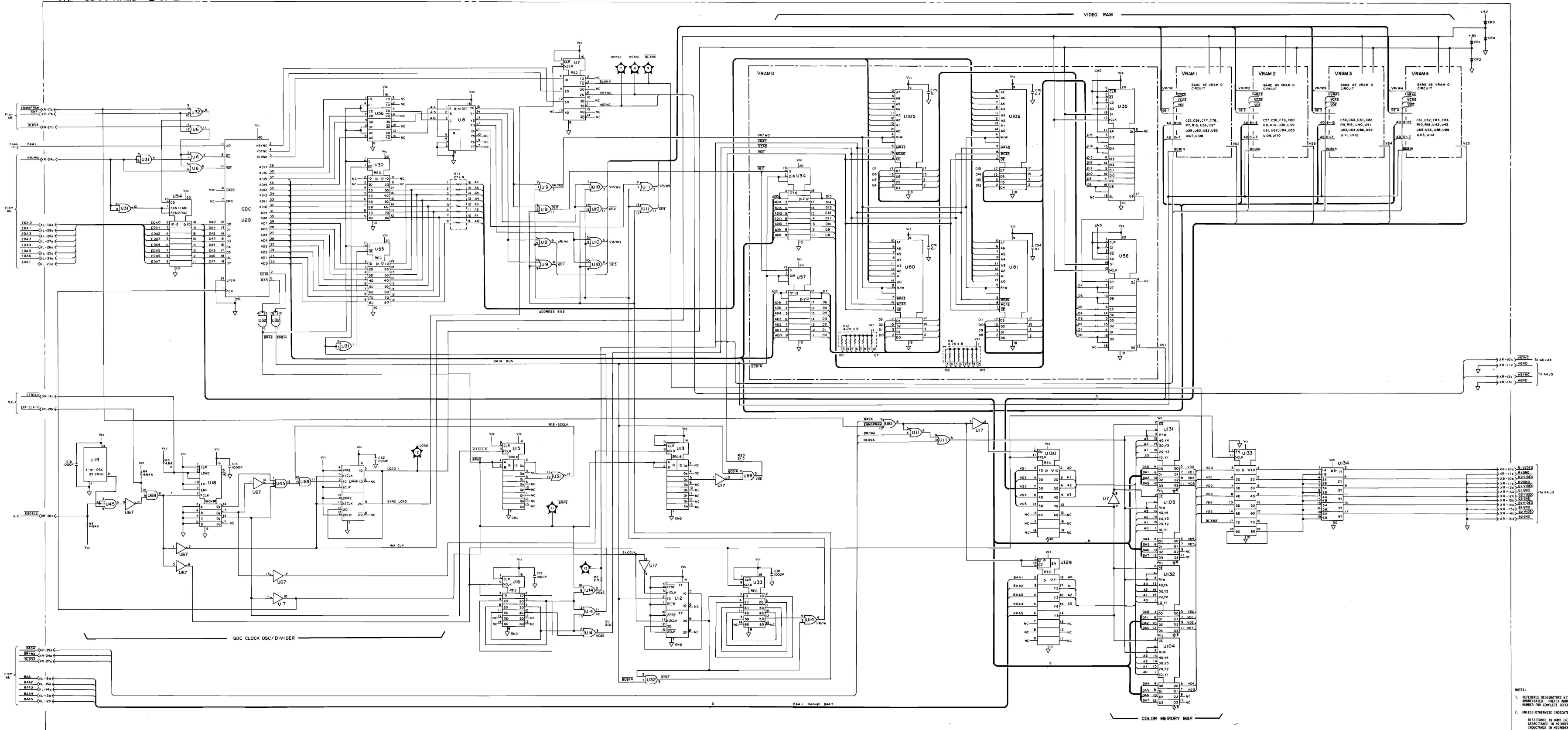

NOTES:
1. REFERENCE DESIGNATORS WITHIN THIS ASSEMBLY ARE ABBREVIATED. PREFIX ABBREVIATION WITH ASSEMBLY NUMBER FOR COMPLETE REFERENCE DESIGNATION.
2. UNLESS OTHERWISE INDICATED:
RESISTANCE IN OHMS (Ω)
CAPACITANCE IN MICROGRAMS (μF)
INDUCTANCE IN MICROHENRIES (μH)

A7 GDC/RAM Schematic Diagram (2 of 2)

A8 Measurement Control Processor Service Sheet

The A8 board contains EEPROM, RAM, ROM, an A-D converter (counter) and the Measurement Control section. CPU B controls the analog section, and reads the measurement data from the A-D converter and writes it to RAM. EEPROM is an electrically erasable ROM in which calibration information is stored. The A-D counters supply the timing signals to the A-D converter, and receives count timing signals from the A-D converter. The measurement control section interfaces with the analog section.

CPU B	A8U31
EEPROM	A8U17
ROM	A8U1 to A8U10
RAM	A8U11 to A8U16

The A8 board's A-D counter outputs the I-TIME and C-CLOCK signals, and inputs the C-GATE and F-GATE signals. Figure A8-1 is the timing chart for the A-D converter. The A-D counter counts the discharge time which is the total time in which the C-GATE and F-GATE signals are high.

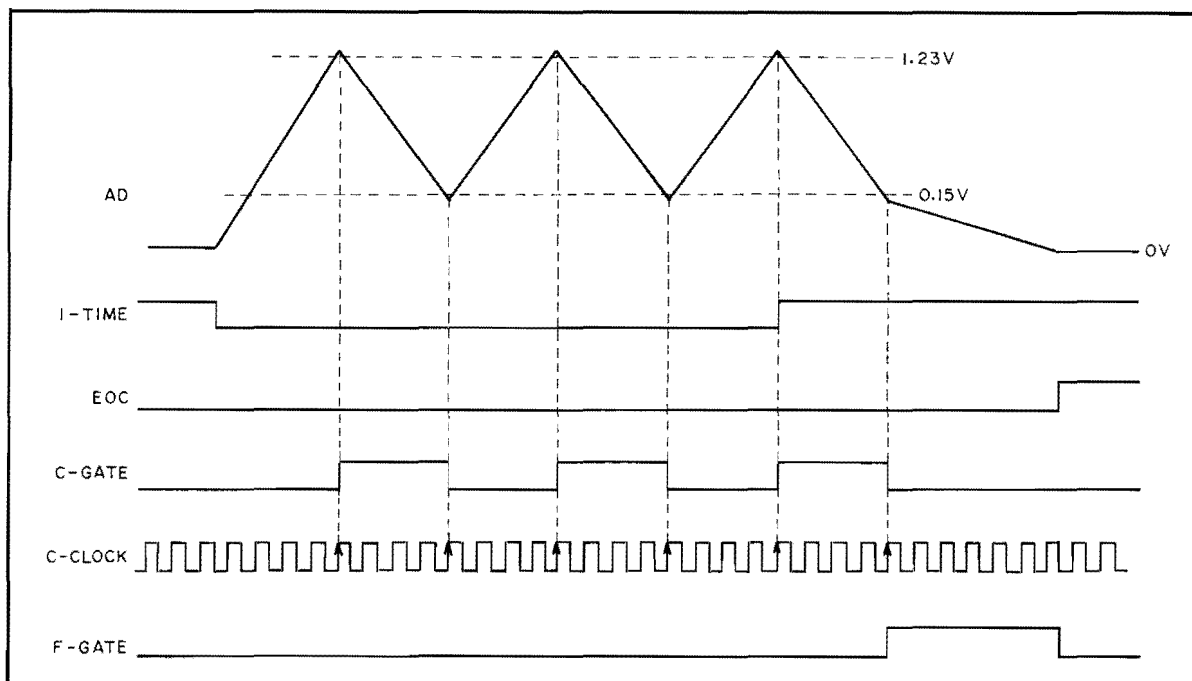

Figure A8-1. A-D Converter Timing Chart

The A8 board's Measurement control section contains the FRACTIONAL N CONTROL, PARALLEL INPUT PORT, PARALLEL OUTPUT PORT, and the SERIAL OUTPUT PORT. The FRACTIONAL N CONTROL circuit sends the setup frequency data to the fractional N loop (A11 board). The data for the fractional N chip is 4 bits wide, but data from CPU B is 8 bits wide. When converting 8 bits to 4 bits, CPU B's data is stored in a different location in memory.

For example, when the fractional N loop is set to 172.345MHz (test frequency is 12.345MHz), Register R1 is loaded serially, the least significant digit first. It is normally necessary to load all 16 digits into the register so that the previous number held in R1 is completely removed and the new number is positioned correctly. The FRACTIONAL N CONTROL section sends data latched by "EX CLK" in reverse order. After setting the frequency, the information is still contained in R1. Note that the frequency can be updated within 10µs when required by pulsing "INV" when the frequency is set (refer to Figure A8-2).

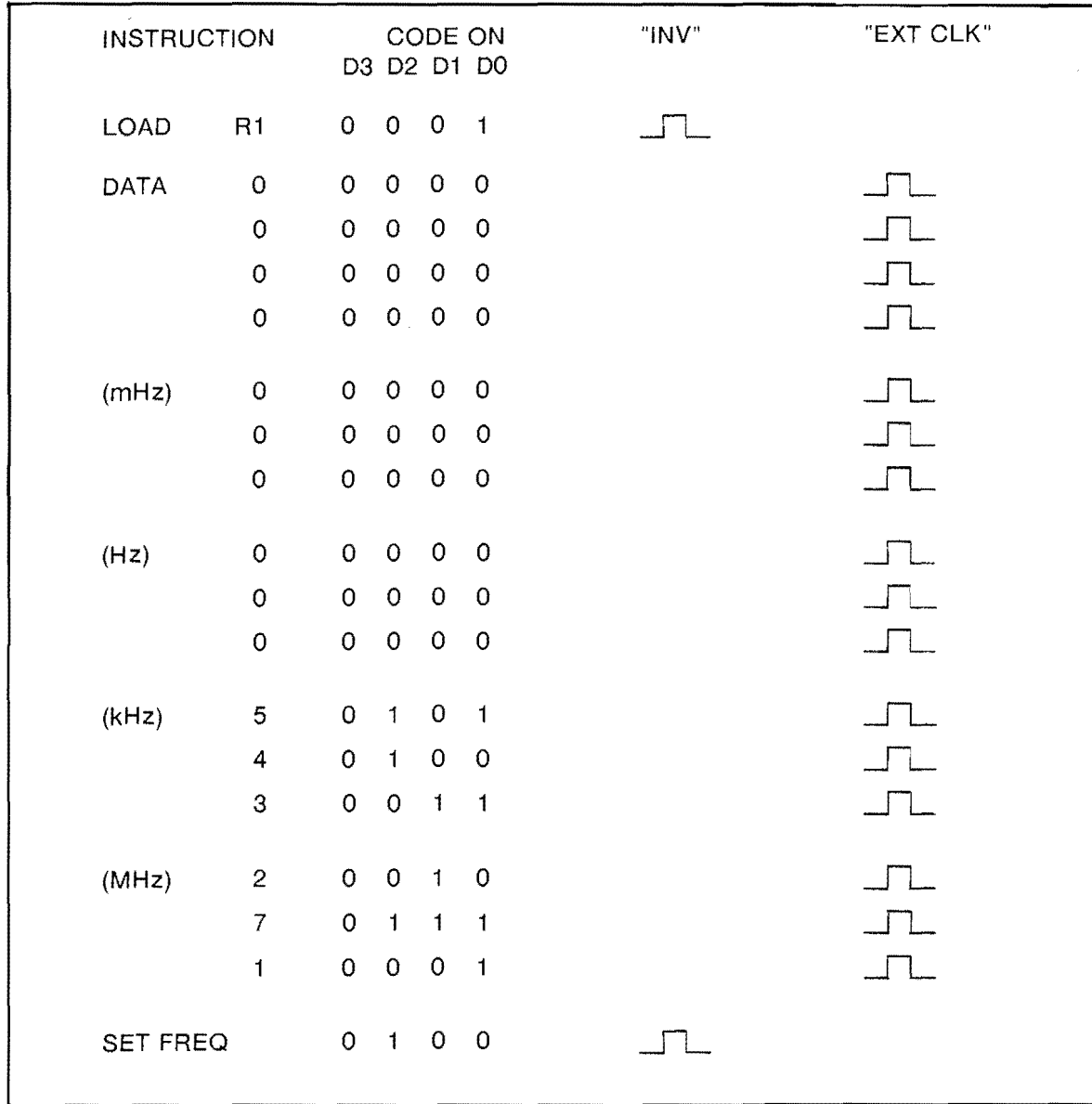

Figure A8-2. Fraction N Loop Setup Example

The **PARALLEL INPUT PORT** is used to read the status of the analog circuits and the VCO unlock/lock status of the fractional N loop. The input data is 24 bits wide, 16 bits of which are supplied by the measurement unit.

Control signals can be sent quickly through the **PARALLEL OUTPUT PORT** to control the analog circuits (switches) which are changed at each measurement point during a measurement. However, the data bus is 8-bits wide and the serial output data is 12-bits wide, the 8-bit latches (A8U65 and U66) are used for the most frequently used signals. Latches A8U67 and U68 are used for the remaining 4-bits.

The **SERIAL OUTPUT PORT** is used to control the analog circuits which are not changed at each measurement point.

Table A8-1. A8 Troubleshooting Aids (1 of 2)

Reference Designator	Use																		
A8DS1 to DS8	DS1 to DS8 are used to indicate the results of the power-on self test. Refer to the power-on self test description.																		
A8DS9	If DS9 lights, CPU B has halted for a BUS ERROR. Cycle the power switch to reset.																		
A8SW1	<p>Normally all bits are set to ON. SW1 is used to perform the following functions.</p> <table border="1" data-bbox="435 625 1333 1115"> <thead> <tr> <th data-bbox="435 625 532 674">SW</th> <th data-bbox="532 625 1333 674">FUNCTION</th> </tr> </thead> <tbody> <tr> <td data-bbox="435 674 532 722">SW1-1</td> <td data-bbox="532 674 1333 722">Set to ON. The OFF position is for design use only.</td> </tr> <tr> <td data-bbox="435 722 532 770">SW1-2</td> <td data-bbox="532 722 1333 770">NOT ASSIGNED</td> </tr> <tr> <td data-bbox="435 770 532 819">SW1-3</td> <td data-bbox="532 770 1333 819">NOT ASSIGNED</td> </tr> <tr> <td data-bbox="435 819 532 867">SW1-4</td> <td data-bbox="532 819 1333 867">NOT ASSIGNED</td> </tr> <tr> <td data-bbox="435 867 532 915">SW1-5</td> <td data-bbox="532 867 1333 915">NOT ASSIGNED</td> </tr> <tr> <td data-bbox="435 915 532 963">SW1-6</td> <td data-bbox="532 915 1333 963">Set to the ON position. OFF is for design use only.</td> </tr> <tr> <td data-bbox="435 963 532 1012">SW1-7</td> <td data-bbox="532 963 1333 1012">NOT ASSIGNED</td> </tr> <tr> <td data-bbox="435 1012 532 1115">SW1-8</td> <td data-bbox="532 1012 1333 1115">Normally set to ON. The OFF position is used for Signature Analysis.</td> </tr> </tbody> </table>	SW	FUNCTION	SW1-1	Set to ON. The OFF position is for design use only.	SW1-2	NOT ASSIGNED	SW1-3	NOT ASSIGNED	SW1-4	NOT ASSIGNED	SW1-5	NOT ASSIGNED	SW1-6	Set to the ON position. OFF is for design use only.	SW1-7	NOT ASSIGNED	SW1-8	Normally set to ON. The OFF position is used for Signature Analysis.
SW	FUNCTION																		
SW1-1	Set to ON. The OFF position is for design use only.																		
SW1-2	NOT ASSIGNED																		
SW1-3	NOT ASSIGNED																		
SW1-4	NOT ASSIGNED																		
SW1-5	NOT ASSIGNED																		
SW1-6	Set to the ON position. OFF is for design use only.																		
SW1-7	NOT ASSIGNED																		
SW1-8	Normally set to ON. The OFF position is used for Signature Analysis.																		
A8SW2	<p>Normally all bits are set to OFF. SW2 is used to perform the following functions.</p> <table border="1" data-bbox="435 1226 1333 1631"> <thead> <tr> <th data-bbox="435 1226 532 1274">SW</th> <th data-bbox="532 1226 1333 1274">FUNCTION</th> </tr> </thead> <tbody> <tr> <td data-bbox="435 1274 532 1373">SW2-1</td> <td data-bbox="532 1274 1333 1373">Normally set to OFF. ON is used to select the Free-run mode which is used for Signature Analysis.</td> </tr> <tr> <td data-bbox="435 1373 532 1472">SW2-2</td> <td data-bbox="532 1373 1333 1472">Normally set to OFF. ON is used to select the BUS-FLOAT state (bus tristated). The BUS-FLOAT state is for manufacturing use only.</td> </tr> <tr> <td data-bbox="435 1472 532 1520">SW2-3</td> <td data-bbox="532 1472 1333 1520">Set to OFF. The ON position is for design use only.</td> </tr> <tr> <td data-bbox="435 1520 532 1631">SW2-4</td> <td data-bbox="532 1520 1333 1631">NOT ASSIGNED</td> </tr> </tbody> </table>	SW	FUNCTION	SW2-1	Normally set to OFF. ON is used to select the Free-run mode which is used for Signature Analysis.	SW2-2	Normally set to OFF. ON is used to select the BUS-FLOAT state (bus tristated). The BUS-FLOAT state is for manufacturing use only.	SW2-3	Set to OFF. The ON position is for design use only.	SW2-4	NOT ASSIGNED								
SW	FUNCTION																		
SW2-1	Normally set to OFF. ON is used to select the Free-run mode which is used for Signature Analysis.																		
SW2-2	Normally set to OFF. ON is used to select the BUS-FLOAT state (bus tristated). The BUS-FLOAT state is for manufacturing use only.																		
SW2-3	Set to OFF. The ON position is for design use only.																		
SW2-4	NOT ASSIGNED																		

Table A8-1. A8 Troubleshooting Aids (2 of 2)

Reference Designator	Use
A8W1	<p>Set to Position 1. W1 is used to select the EEPROM erase mode and is normally set to Position 1.</p> <p>Position 1: BYTE ERASE Position 2: CHIP ERASE</p> <p>The CHIP ERASE position is for design use only.</p>
A8W2	<p>A8W2 is the EEPROM write enable/disable selector.</p> <p>Position 1: Disable EEPROM write Position 2: Enable EEPROM write</p>
A8W3 to W6	<p>Normally set Position 1. W3 to W6's positions are determined by the type of ROM being used.</p> <p>Position 1: 128Kbit ROM Position 2: 256Kbit ROM</p>

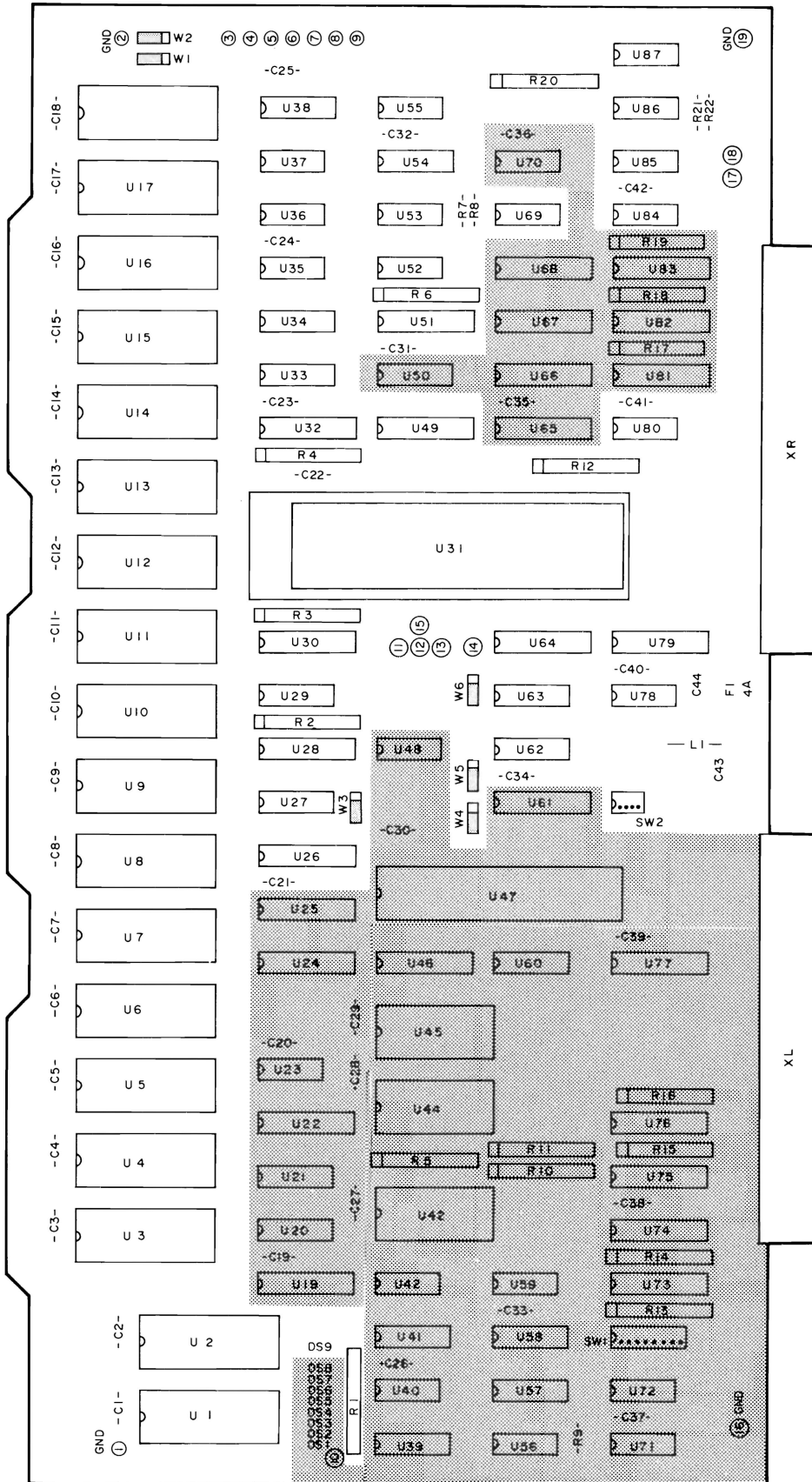

A8 Measurement Control Processor Component Locations (1 of 3)

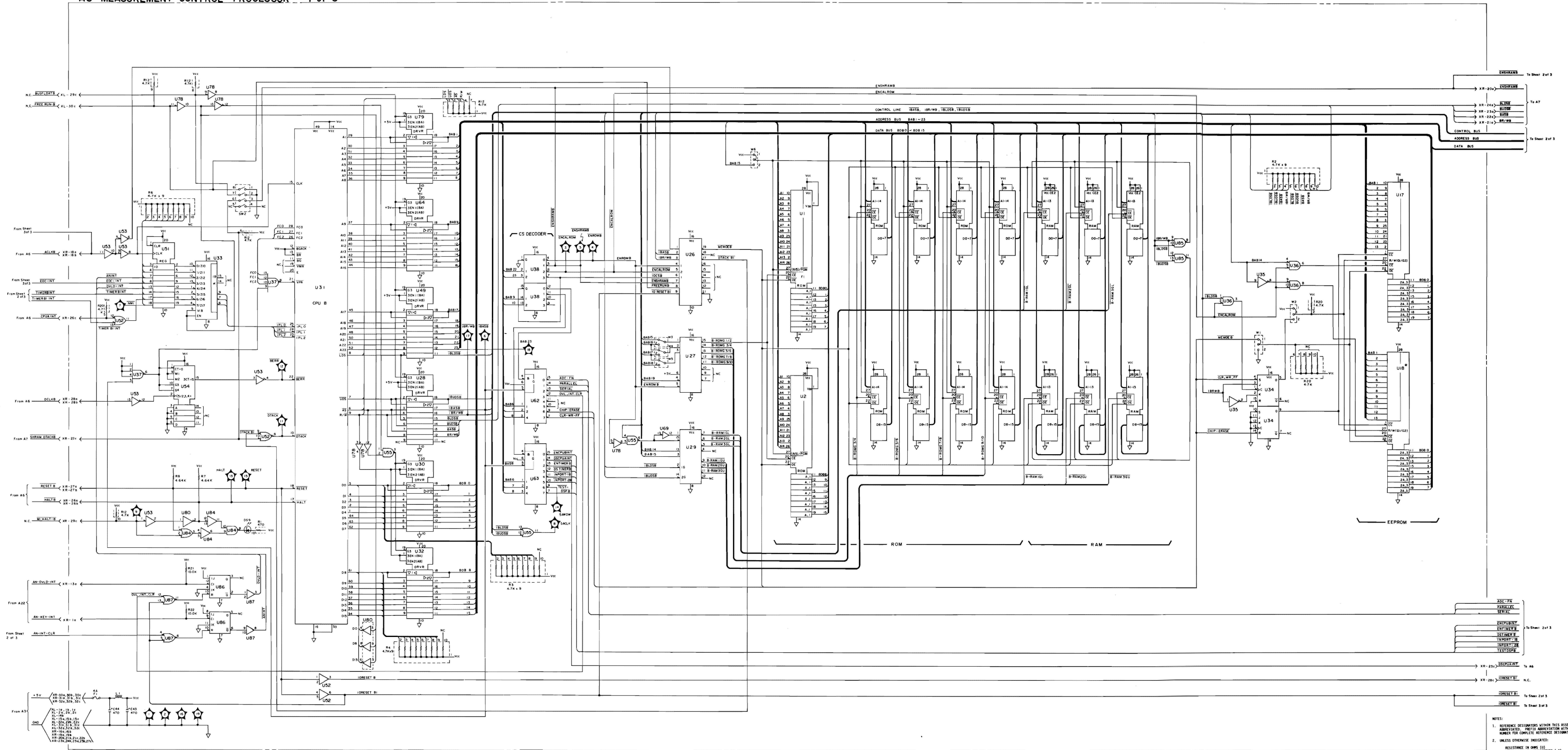

NOTES:
 1. REFERENCE DESIGNATORS WITHIN THIS ASSEMBLY ARE ABREVIATED. PREFIX ABBREVIATION WITH ASSEMBLY NUMBER FOR COMPLETE REFERENCE DESIGNATOR.
 2. UNLESS OTHERWISE SPECIFIED:
 RESISTANCE IN OHMS (Ω)
 CAPACITANCE IN MICROFARADS (μ F)
 INDUCTANCE IN MICROHENRIES (μ H)

*U18 is not installed

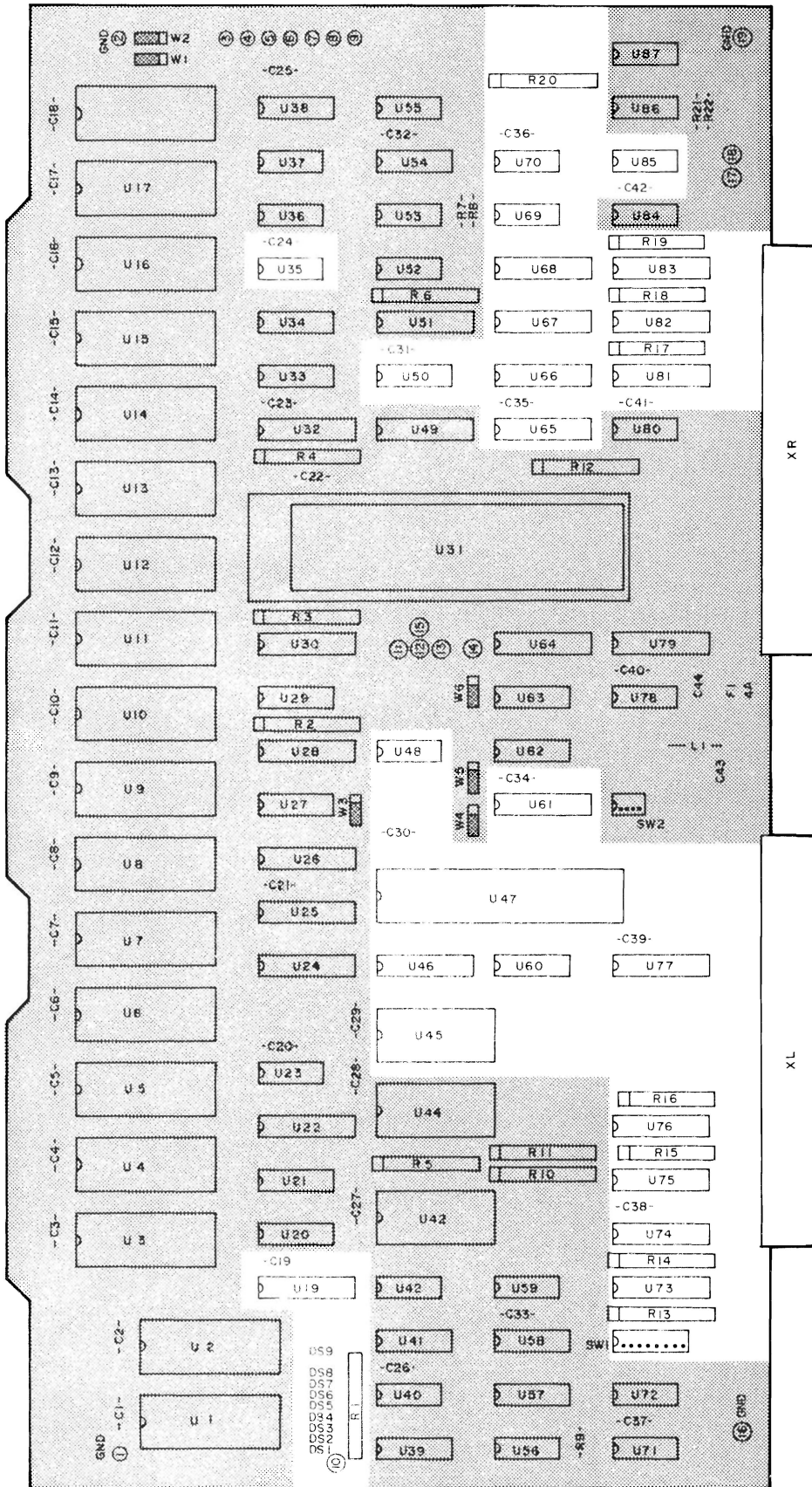

A8 Measurement Control Processor Component Locations (2 of 3)

A8 MEASUREMENT CONTROL PROCESSOR 2 of 3

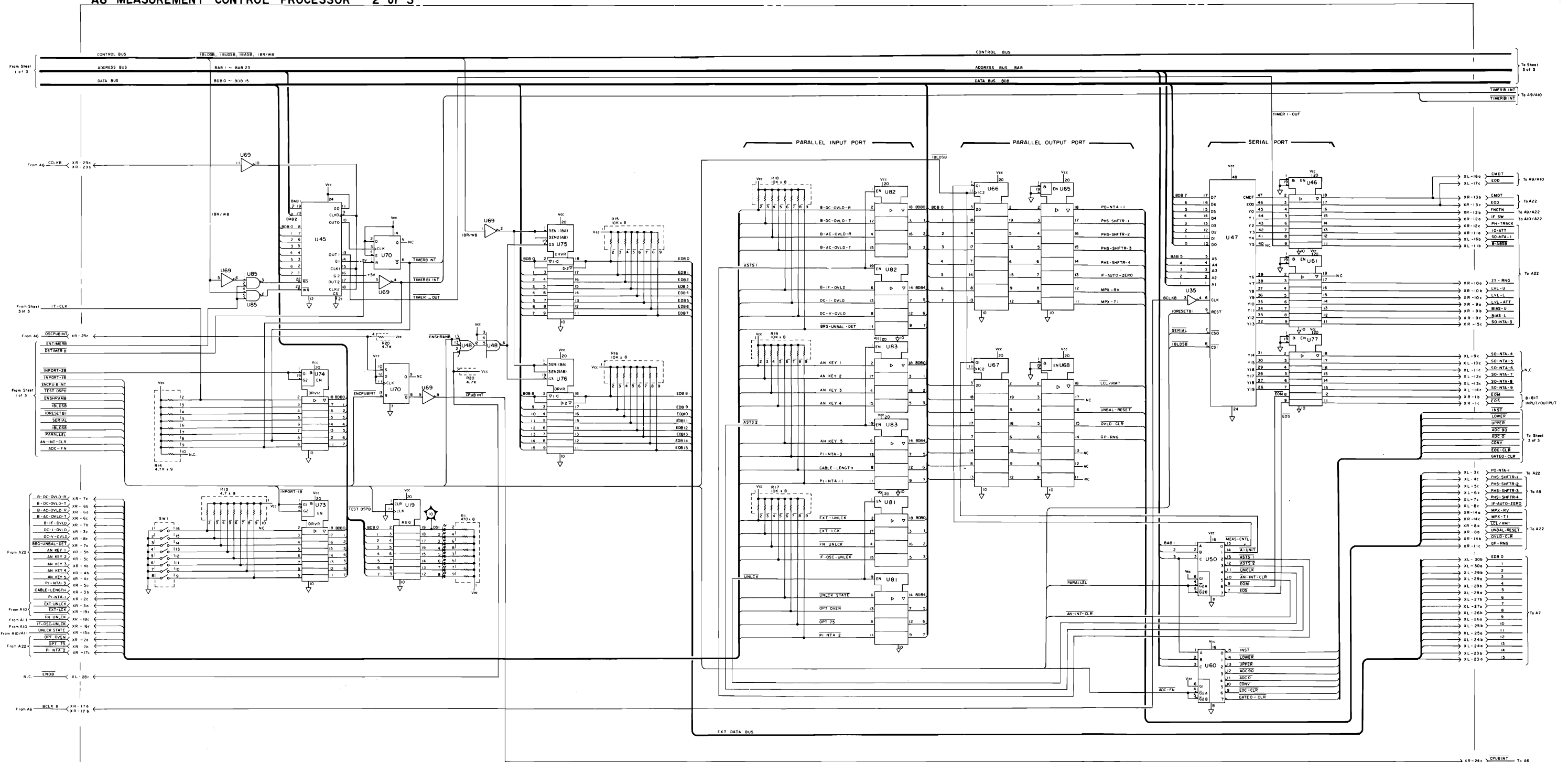

NOTES:
 1. REFERENCE DESIGNATORS WITHIN THIS ASSEMBLY ARE ABBREVIATED. PREFIX ABBREVIATION WITH ASSEMBLY NUMBER FOR COMPLETE REFERENCE DESIGNATOR.
 2. UNLESS OTHERWISE INDICATED:
 RESISTANCE IN OHMS (Ω)
 CAPACITANCE IN MICROFARADS (μF)
 INDUCTANCE IN MICROHENRIES (μH)

A8 Measurement Control Processor Schematic Diagram (2 of 3)

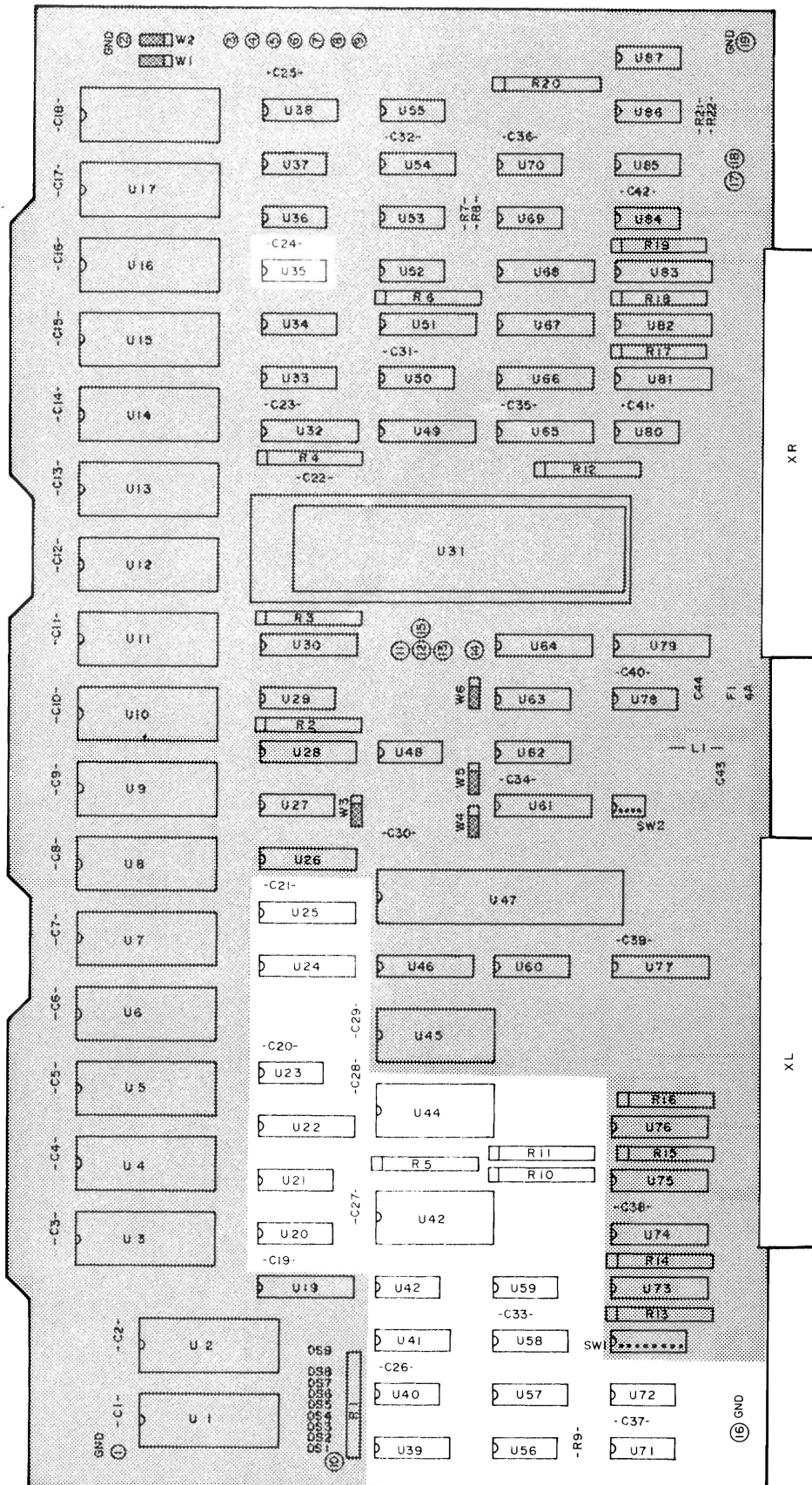

A8 Measurement Control Processor Component Locations (3 of 3)

A8 MEASUREMENT CONTROL PROCESSOR 3 of 3

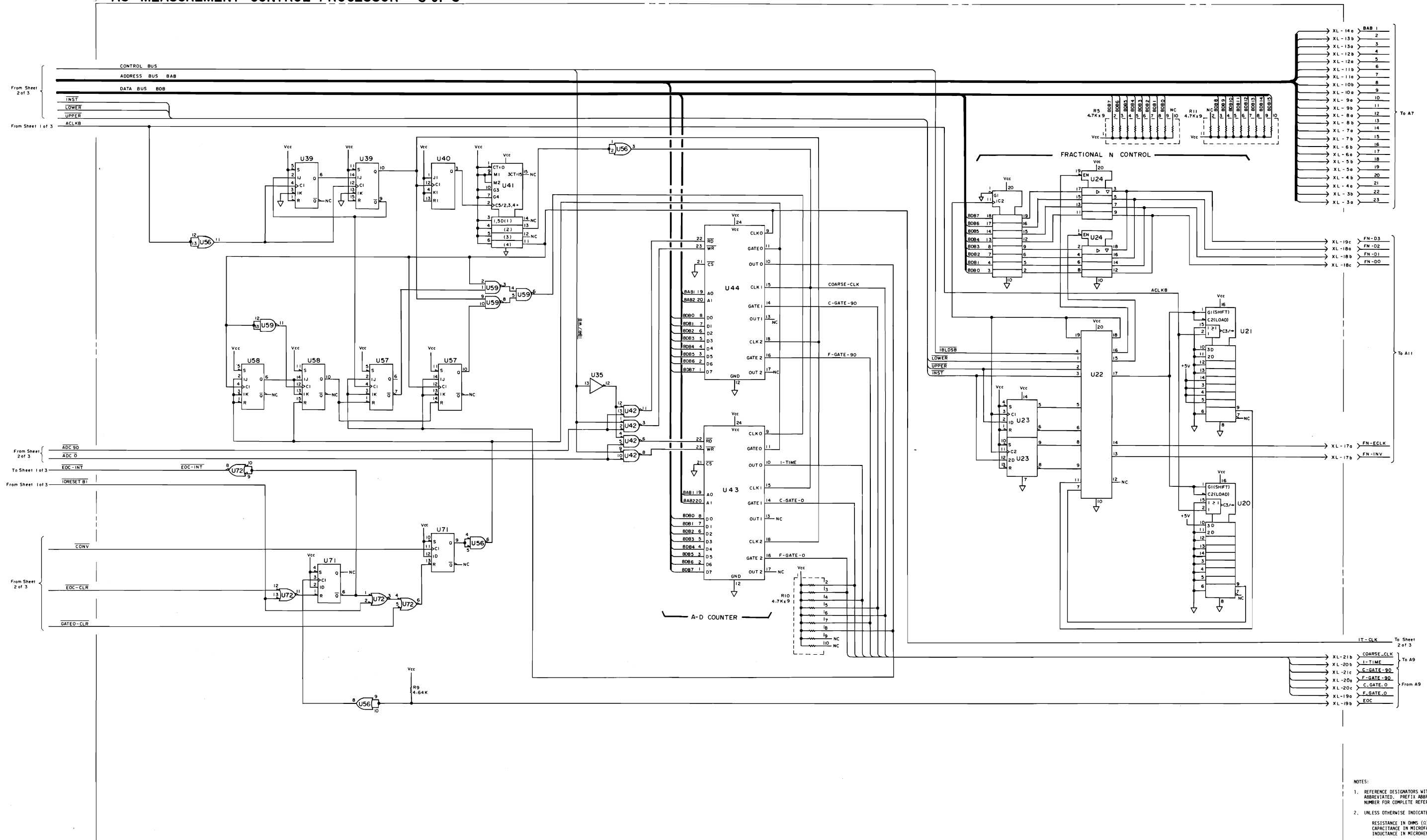

NOTES:
 1. REFERENCE DESIGNATORS WITHIN THIS ASSEMBLY ARE ABBREVIATED. PREFT'S ABBREVIATION WITH ASSEMBLY NUMBER FOR COMPLETE REFERENCE DESIGNATOR.
 2. UNLESS OTHERWISE INDICATED:
 RESISTANCE IN OHMS (Ω)
 CAPACITANCE IN MICROFARADS (μF)
 INDUCTANCE IN MICROHENRIES (μH)

A8 Measurement Control Processor Schematic Diagram (3 of 3)

A9 Phase Detector/A-D Converter Service Sheet

Figure A9-1 is the block diagram of the A9 Phase Detector/A-D Converter. The A9 board has two phase detectors, two multi-slope A-to-D converters, a detection phase generator, A-D control logic circuit, and the voltage regulators for the A9, A10, and A11 boards. In order to decrease the measurement time, the 0° and 90° components of the vector voltage are simultaneously detected and digitized.

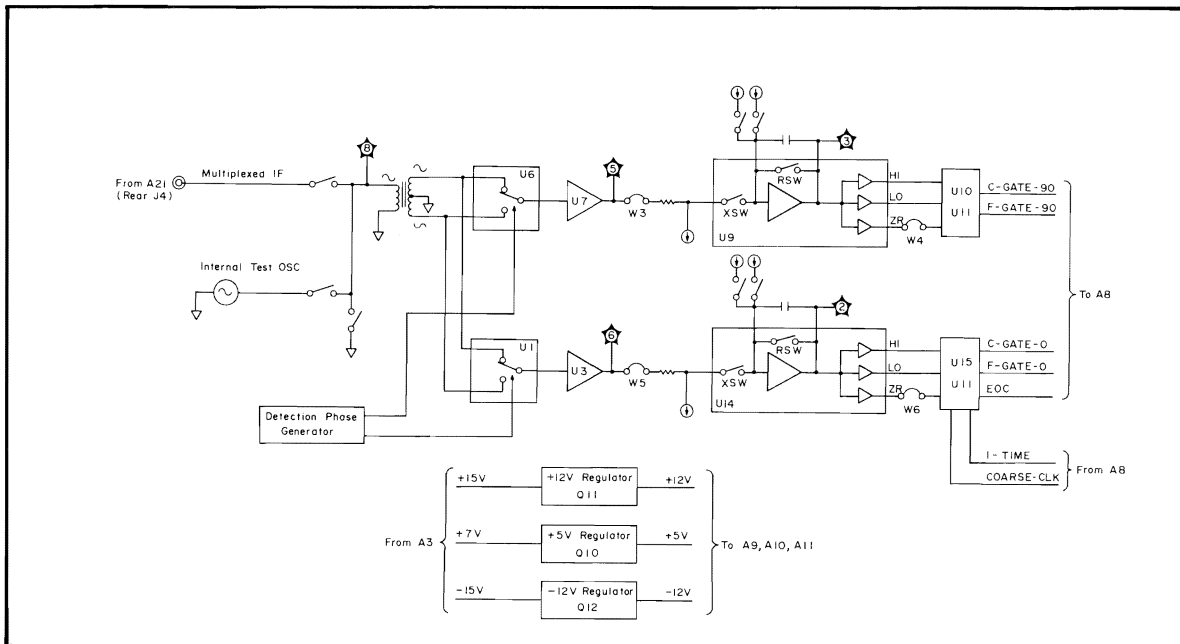

Figure A9-1. A9 Board Block Diagram

The unregulated voltage from the A3 board is regulated on the A9 board to 5V and $\pm 12V$ for the A9, A10 and A11 boards. The 5V supply is adjustable, and the $\pm 12V$ supplies track the 5V supply.

The multiplexed IF signal from the A21 board in the measurement unit is switched by the auto-zero circuit. The auto zero circuit outputs a zero signal for zero offset measurement, the multiplexed IF signal to be measured, and the test IF signal from the internal oscillator. The internal oscillator is used during self test and for troubleshooting.

The 0° and 180° IF signal outputs of Transformer T1 are used for double wave detection. Phase detector switches U1 and U6 are driven by the detection phase generator. Figure A9-2 shows an example of double wave phase detection. The detection phase can be shifted by 22.5° and still maintain a 90° phase difference. When the **AVERAGING** value is more than 2, the detection phases are alternated to eliminate measurement errors caused by, phase detector unbalance, the A-D converters, and by the detection phase error not being exactly 90° . Table A9-1 gives relationships between AVERAGING TIME and Relative Detection Phase.

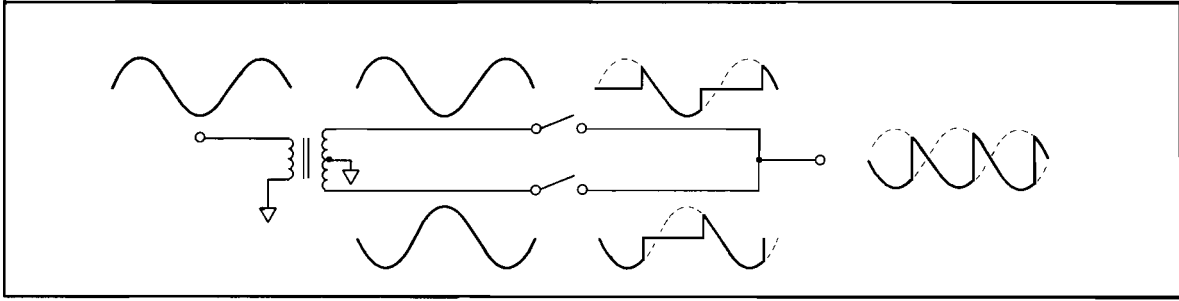

Figure A9-2. Double Wave Phase Detection Example

Table A9-1. AVERAGING and Relative Detection Phase

Relative Detection Phase;	AVERAGING TIME
0/ 90°	1, 2, 4, 8, 16
180/ 270°	2, 4, 8, 16
90/ 180°	4, 8, 16
270/ 0°	4, 8, 16
45/ 135°	8, 16
225/ 315°	8, 16
135/ 225°	8, 16
315/ 45°	8, 16
22.5/ 112.5°	16
202.5/ 292.5°	16
112.5/ 202.5°	16
292.5/ 22.5°	16
67.5/ 157.5°	16
247.5/ 337.5°	16
57.5/ 247.5°	16
337.5/ 67.5°	16

The detected dc voltage, proportional to the 0° and 90° vector voltage components, is input to the Multi-slope A-D converter. The simplified circuit diagram of a multi-slope A-D converter is shown in Figure A9-3. U9 and U14 are HIC (hybrid IC) A-D converters which contain an integrator and three comparators. PALs (Programmable Array Logic ICs) U10 and U15 are used as the A-D control logic. R47 and R75 are offset current sources used to offset the input signal level by one-half of the full-scale range. This makes it possible to digitize both negative and positive input signals. R65 and R85 are the coarse current sources, and R68 and R88 are the fine current sources. The I-TIME and COURSE-CLK signals originate on the A8 board.

I-TIME is a TTL level signal which goes **LOW** during the integration period. COURSE-CLK is a TTL level clock for the coarse counter to synchronize the gate timing. Three comparators are used to detect the level of the integrated dc voltage. The outputs from the comparators, I-TIME, and COURSE-CLK are inputs to the PALs which output signals to the control logic circuit. The HI comparator detects if the integrator output is greater than 1.2V. The LO comparator detects if the integrator output is less than 0.1V. The ZR comparator detects if the integrator output is a positive voltage. The current ratio of coarse current source to the fine current source is 64. The period of the coarse count clock is $2.4\mu\text{s}$ and the period of fine count clock is 300ns, so one coarse count is equal to 512 fine counts. The counter is located on the A8 board.

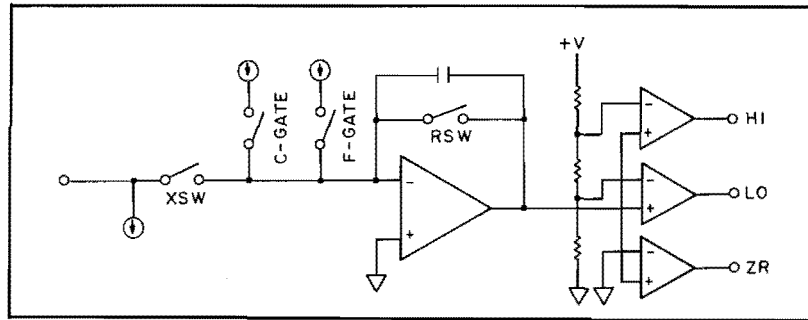
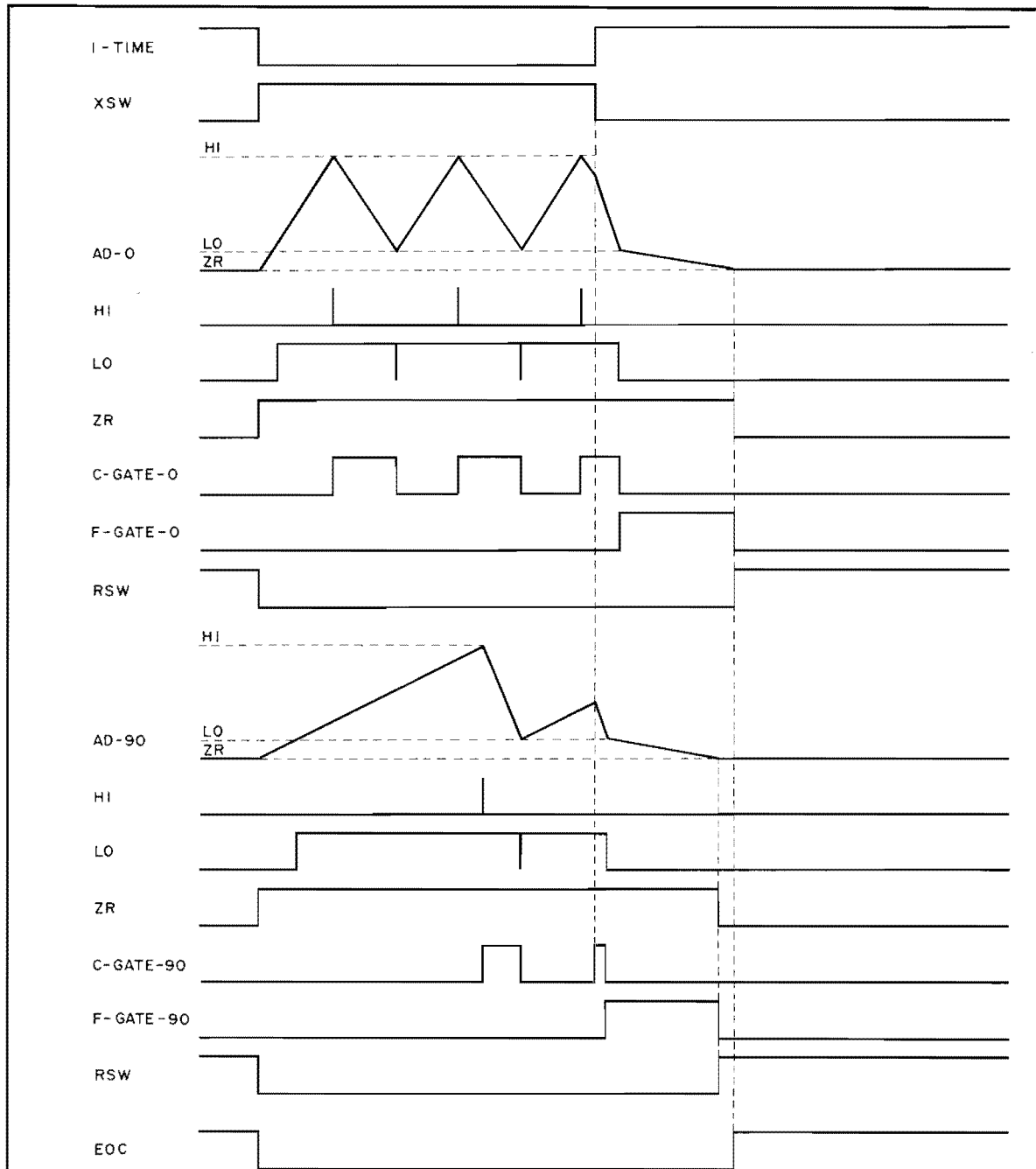

Figure A9-3. Multi-Slope A-D Converter



Critical timing is shown below.

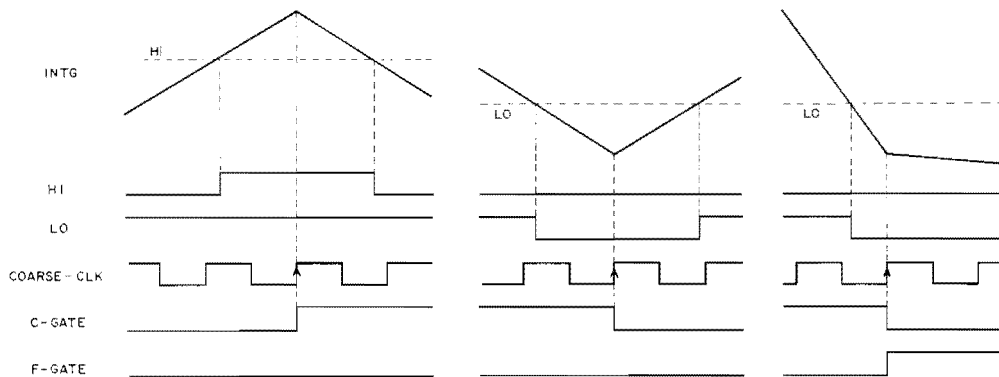

Figure A9-4. A-D Converter Timing Diagram

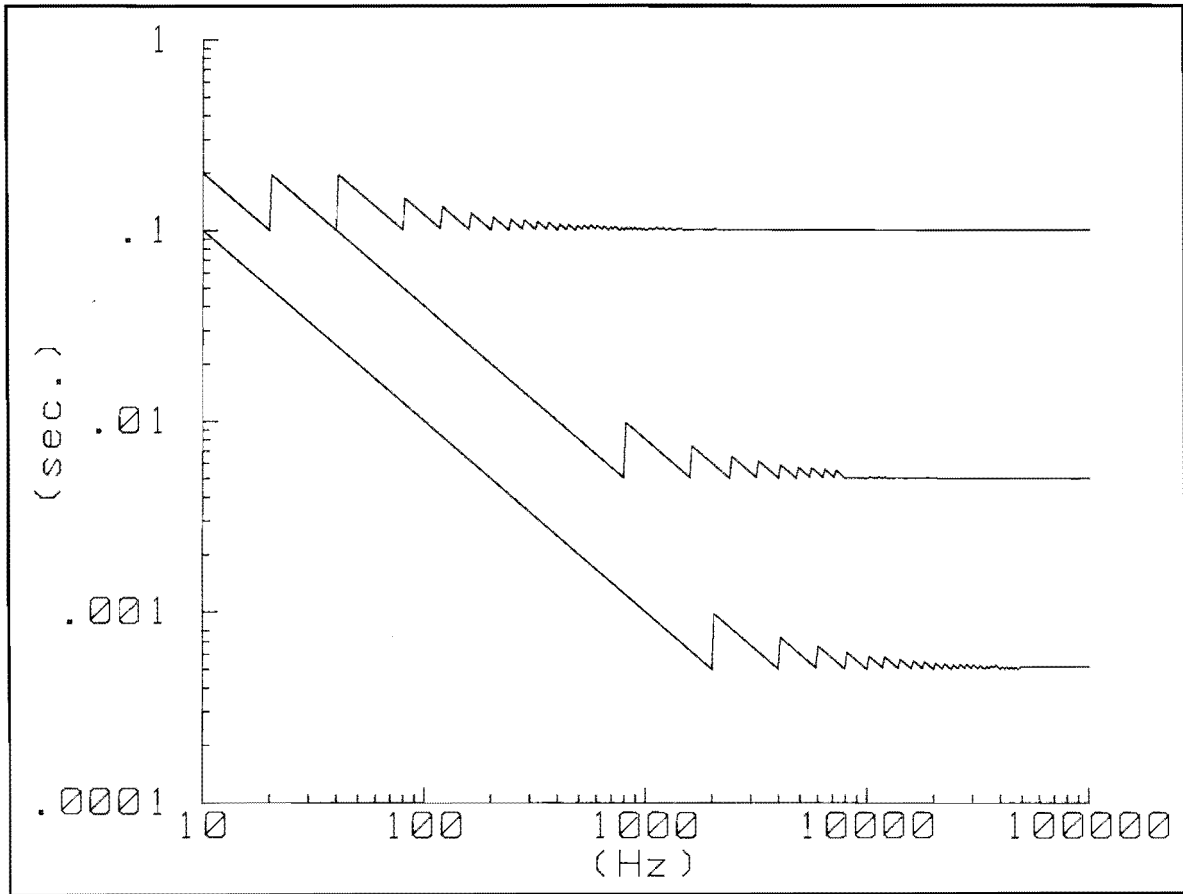

Figure A9-5. INTEG TIME and Measurement Frequency

Table A9-2. A9 Troubleshooting Aids

Reference Designator	Description	Use
W3, W5	A-D converter input	<p>N: Connects to phase detected measurement signal.</p> <p>T: Full-scale dc input to the A-D converter.</p> <p>OPEN: DC voltage (maximum $\pm 2V$) can be applied to the center pin to check the operation of the A-D converter.</p>
W4, W6	Zero comparator signal	<p>N: Connects the zero comparator's output to the control logic circuit.</p> <p>T: Connects zero volts to the control logic circuit. This is useful when the zero comparator is not functional.</p>
W7	Phase detector input selection.	<p>N: Normally connects to the multiplexed IF signal. In self test #10 through #12, it is automatically connected to the internal test oscillator.</p> <p>T: Connects to the internal test oscillator.</p> <p>OPEN: Connects to the multiplexed IF signal.</p>
W8	AUTO ZERO control	<p>N: Q7 and Q8 or Q9 are used to zero the input to U8.</p> <p>T: Auto zero operation is disabled and the IF signal is continuously applied to U8.</p>

Table A9-3. A9 Troubleshooting Data (1 of 2)

Step	HP 4194A Settings	Measurement Setup	Main Parameters	Waveform
1	W7:Test pos. CENTER: 1MHz SPAN:0Hz INTEG TIME: MED DTIME:20	Oscilloscope 2ms/DIV CH-A to TP4 dc coupled 2V/DIV CH-B to TP8 dc coupled 1V/DIV TRIGGER:CH-A NEGATIVE	CH-A:TTL level low period is approx. 5ms CH-B:approx. 2.6Vpp	
2	same as 1	Oscilloscope 2ms/DIV CH-A to TP4 DC coupled 2V/DIV CH-B to TP5 or TP6 DC coupled 0.5V/DIV TRIGGER:CH-A NEGATIVE	CH-B $< \pm 2V$	
3	W7:Test pos. W8:Test pos. CENTER: 1MHz SPAN:0Hz	Oscilloscope 2μs/DIV CH-A to TP5 DC coupled 1V/DIV CH-B to TP6 DC coupled 1V/DIV TRIGGER:CH-A	DC voltage $< \pm 2V$ Ripple interval: 3.2μs	
4	A8SW1-7 (bit 6):ON W3:open W5:open CENTER: 1MHz SPAN:0Hz INTEG TIME. SHORT DTIME:20 RZ1 (50Ω range hold)	Oscilloscope 500μs/DIV CH-A to TP3 DC coupled 0.5V/DIV CH-B to TP2 DC coupled 0.5V/DIV TRIGGER:EXT to TP4 NEGATIVE	Waveform	

Table A9-3. A9 Troubleshooting Data (2 of 2)

Step	HP 4194A Settings	Measurement Setup	Main Parameters	Waveform
5	A8SW1-7 (bit 6):ON W3,W5:open CENTER: 1MHz SPAN:0Hz INTEG TIME: MED DTIME:20 RZ1 (50Ω range hold)	Oscilloscope 2ms/DIV CH-A to TP3 dc coupled 0.5V/DIV CH-B to TP2 dc coupled 0.5V/DIV TRIGGER:EXT to TP4 NEGATIVE		
6	A8SW1-7 (bit 6):ON W3:Test pos. W5:Test pos. CENTER: 1MHz SPAN:0Hz INTEG TIME: SHORT DTIME:20 RZ1 (50Ω range hold)	same as 4		
7	A8SW1-7 (bit 6):ON W3:Test pos. W5:Test pos. CENTER: 1MHz SPAN:0Hz INTEG TIME: MED DTIME:20 RZ1 (50Ω range hold)	same as 5		
8	A8SW1-7 (bit 6):ON W3,W5:open W6:Test pos. W6:Test pos. CENTER: 1MHz SPAN:0Hz INTEG TIME: SHORT DTIME:20 RZ1 (50Ω range hold)	same as 5		

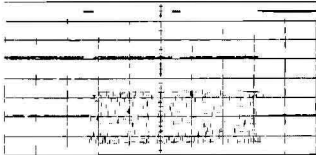
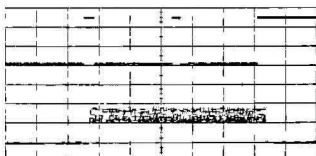
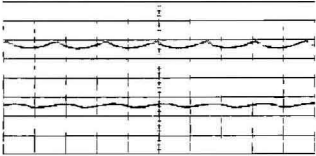
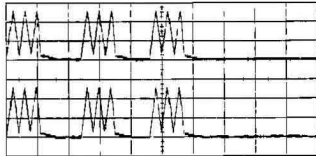
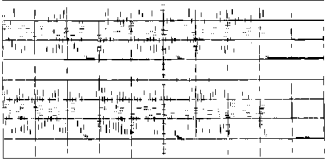
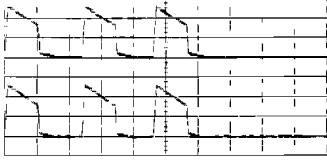
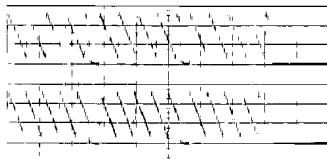
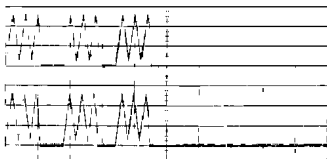
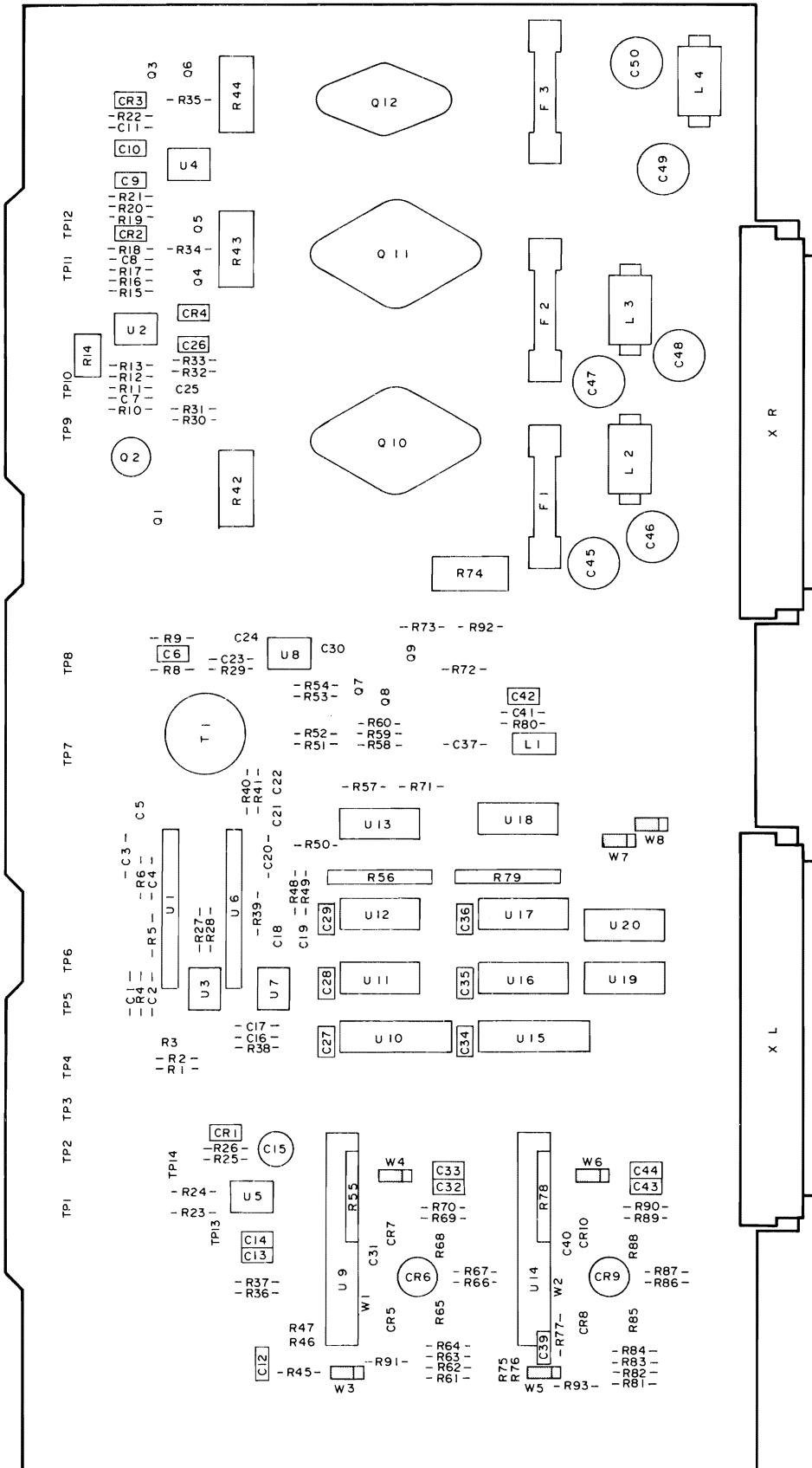

A9 Phase Detector/A-D Converter Component Locations
8-100

A9 PHASE DETECTOR/A-D CONVERTER

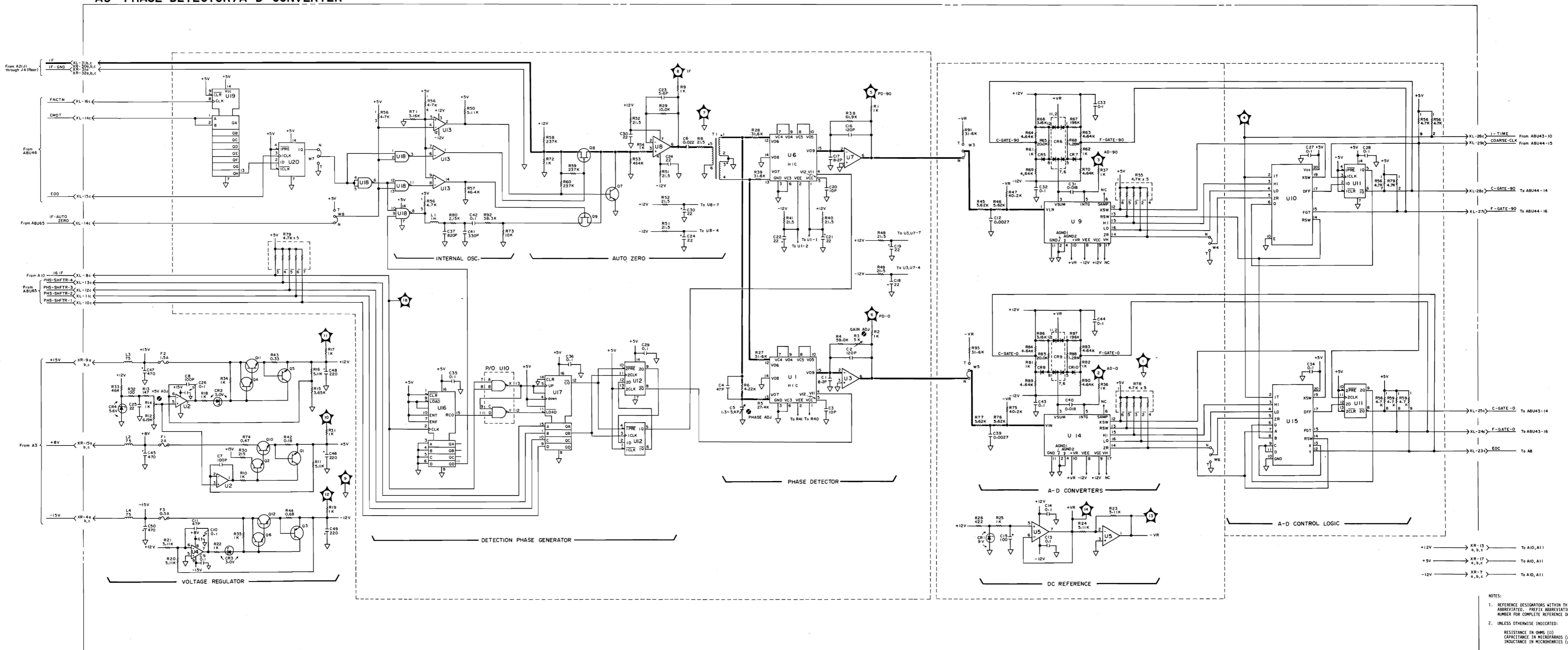

NOTES:
 1. REFERENCE DESIGNATORS WITHIN THIS ASSEMBLY ARE ABBREVIATED. PREFIX ABBREVIATION WITH ASSEMBLY NUMBER FOR COMPLETE REFERENCE DESIGNATOR.
 2. UNLESS OTHERWISE INDICATED:
 RESISTANCE IN OHMS (Ω)
 CAPACITANCE IN MICROFARADS (μF)
 INDUCTANCE IN MICRONERIESES (μH)

A9 Phase Detector/A-D Converter Schematic Diagram

A10 Reference Frequency Generator Service Sheet

Figure A10-1 is the block diagram of the A10 Reference Frequency Generator. The A10 board contains a 160MHz and a 160MHz-IF reference frequency generators, a frequency divider, and a phase detector. The 160MHz generator can be synchronized to an EXTERNAL REFERENCE signal, and the 160MHz-IF generator is phase-locked to the 160MHz generator. The divider circuit divides the 160MHz generator's signal to produce all of the necessary reference clocks. The phase detector's output is used to maintain phaselock between the 160MHz-IF and 160MHz generators.

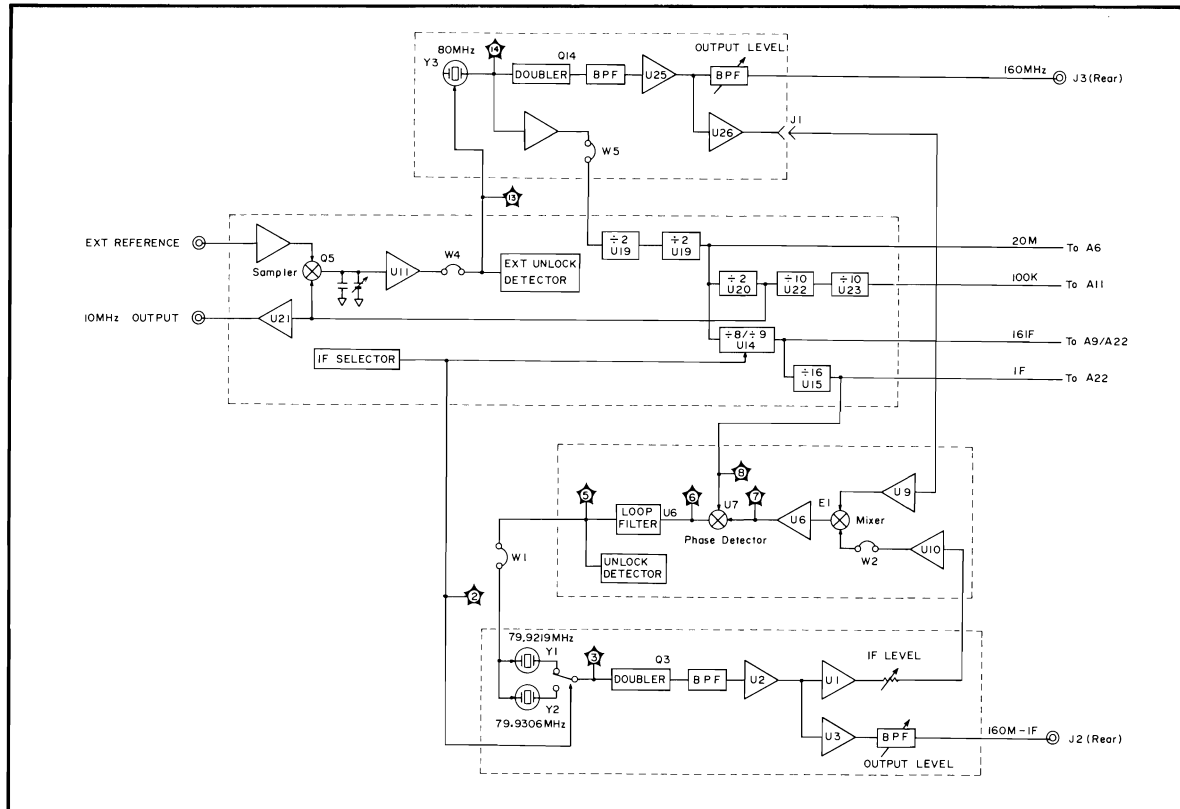

Figure A10-1. A10 Board Block Diagram

The 160MHz generator is constructed using a 80MHz VCO (Y3, Q9 and Q10), frequency doubler (Q14), band pass filters, and amplifiers U25 and U26. The dc control voltage from the Sample and Hold circuit in the divider section varies the capacitance of CR27 and CR28 to adjust the frequency of the 80MHz VCO. Q11 and Q13 form a level converter which is used to drive the TTL frequency divider. The doubler (Q14) is a saturated amplifier which produces strong second harmonics, and the band pass filters reject all frequencies other than the second harmonic (160MHz). The 160MHz signal goes to J3 on the control unit's rear panel and to the phase detector. Amplifiers U25 and U26's gain is approximately 18dB.

The divider section includes frequency dividers, a serial-to-parallel data converter, a sample and hold, and an external reference unlock detector. The dividers divide the 80MHz VCXO signal into 20MHz, 10MHz, 16IF, IF, and 100kHz. The 20MHz signal is used as the clock for the digital control circuits. The 10MHz signal is output through the 10MHz OUTPUT terminal on the control unit's rear panel. The 16IF signal is used by the A9 and A22 boards to generate the reference phase detecting signal. The IF signal is used by the A10 board to control the frequency of the 160MHz-IF generator, and by the phase detector on the A22 board. The 100kHz signal is used as the phase reference signal for the VCO on the A11 board. The IF frequency is 156.25kHz (U14 functions as a divide by 8 counter) or 138.88kHz (U14 functions as a divide by 9 counter) and is determined by the 4194A's test frequency setting so as not to interfere with the measurement. The serial control signal (CMDT), from the A8 board, is latched by U17 and U18 using the IF-SW and EOD signals and is used as the IF select signal.

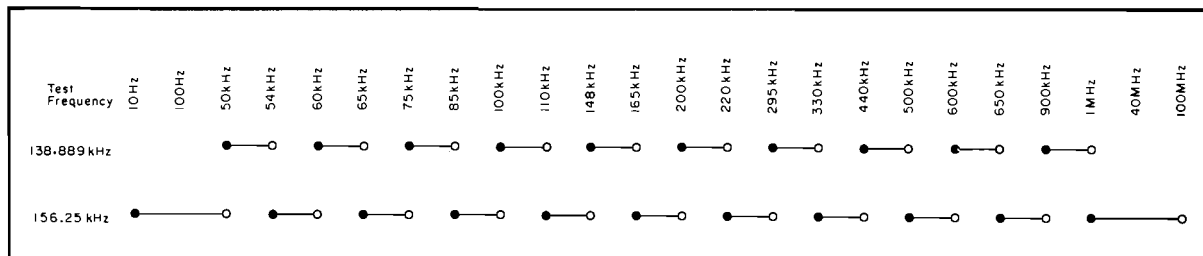

Figure A10-2. Test Frequency and IF Relationship

Q5 chops the 10MHz signal at the rate of the EXTERNAL REFERENCE signal. The EXTERNAL REFERENCE signal is amplified by Q7, two inverters of U12 and Q6, to drive Q5. U11 superimposes a dc voltage onto the chopped signal and supplies the control voltage to the 80MHz VCXO. The dc voltage added determines the 80MHz VCXO's frequency when an EXTERNAL REFERENCE signal is not applied. Four inverters of U12 and two NAND gates of U21 are used to determine if an EXTERNAL REFERENCE is applied, and if the 160MHz reference signal is synchronized to the EXTERNAL REFERENCE signal.

The 160MHz-IF generator circuit is almost the same as that used for the 160MHz generator. The 160MHz-IF signal is output through J2 on the control unit's rear panel. Two crystals are used to generate the IF frequencies. One of the crystals is connected into the circuit by switching diodes CR1 - CR4, depending on the level of the dc signal from the IF selector.

The Phase detector consists of a mixer, phase detector, loop filter, and a phase lock detector. The 160MHz and 160MHz-IF signals are mixed in double balanced mixer E1 to produce the difference frequency, IF. The inverters of U8 buffers the IF signals from the mixer and the divider. U7 detects the phase difference between the two IF signals. U6 integrates the detected signal and supplies the dc control voltage to the 80MHz-IF/2 VCXO. Two comparators of U5 and two of U4's AND gates are used as phase lock detectors to determine if the 80MHz-IF/2 VCXO is phase-locked to the 80MHz VCXO, and to determine the direction of unlock (too high or too low). LED DS1 lights if the 80MHz-IF/2 VCXO is unlocked.

Table A10-1. A10 Troubleshooting Aids

Reference Designator	Description	Use
DS1	80MHz-IF/2 VCXO unlock indicator	
J1	160MHz phase detector block	Disconnected to isolate the 80 MHz-IF/2 VCXO from the 80MHz VCXO.
W1 voltage	80MHz-IF/2 VCXO control put to the 80MHz-IF/2 VCXO.	N: Connects phase detector output to the 80MHz-IF/2 VCXO. T: Supplies zero volts to the 80MHz-IF/2 VCXO. Open: Applies less than +8V to the center pin to check 80MHz-IF/2 VCXO.
W2	160MHz-IF to phase detector block	N: Connects 160MHz-IF to phase detector block. T: Disconnects 160MHz-IF from phase detector block.
W3	IF select signal	N: The IF frequency is automatically controlled by the test frequency setting. T: IF frequency is SET to 138.88kHz. Open: IF frequency is SET to 156.25kHz.
W4	80MHz VCXO control voltage	N: Connects the External Reference sampler output to the 80MHz VCXO. T: Supplies zero volts to the 80MHz VCXO. Open: Applies less than +8V to the center pin to check 80MHz VCXO operation.
W5	80MHz TTL signal to divider block	N: Connects 80MHz to the divider block. T: Disconnects 80MHz from the divider block.

Table A10-2. A10 Troubleshooting Data (1 of 3)

Step	HP4194A Settings	Measurement Setup	Main Parameters	Waveform
1	EXT REF: disconnected	Spec. Analyzer INPUT #2 to J3 on the Control Unit rear panel CENTER:160MHz SPAN:500kHz ResBW:3kHz VBW:3kHz RefLevel:0dBm dB/Div:10dB	Level: -5.0dBm ±1dB Frequency: 160MHz ±3.2kHz	
2	EXT REF: disconnected CENTER:1MHz SPAN:0Hz	Spec. Analyzer INPUT #2 to J2 on the Control Unit rear panel CENTER: 159.8438MHz SPAN:500kHz ResBW:3kHz VBW:3kHz RefLevel:0dBm dB/Div:10dB	LEVEL: -7.0dBm±1dB Frequency: 159.84375MHz ±3.2kHz	
2'	same as 2 except CENTER: 990kHz	same as 2 except CENTER: 159.8611MHz	LEVEL: -7.0dBm±1dB Frequency: 159.8611MHz ±3.2kHz	
3	EXT REF: disconnected	Oscilloscope 50ns/DIV CH-A to 10MHz OUTPUT (on the rear panel) 50Ωterminated 1V/DIV TRIGGER:CH-A	Level:1.4 to 2.8Vpp Period:100ns	
4	EXT REF: disconnected	Spec. Analyzer INPUT #2 to TP14 CENTER:80MHz SPAN:500kHz ResBW:3kHz VBW:3kHz RefLevel:0dBm dB/DIV:10dB	LEVEL:-31.5 dBm±1.5dB Frequency: 80MHz±1.6kHz	

Table A10-2. A10 Troubleshooting Data (2 of 3)

Step	HP4194A Settings	Measurement Setup	Main Parameters	Waveform
5	EXT REF: disconnected CENTER: 1MHz SPAN:0Hz	Spec. Analyzer INPUT #2 to TP3 CENTER: 79.9219MHz SPAN:500kHz ResBW:3kHz VBW:3kHz RefLevel:0dBm dB/DIV:10dB	Level:-31.5dBm ±1.5dB Frequency: 79.9219MHz ±1.6kHz	
5'	same as 5 except CENTER: 990kHz	same as 5 except CENTER: 79.9306MHz	Level:-31.5dBm ±1.5dB Frequency: 79.9306MHz ±1.6kHz	
6	EXT REF: disconnected CENTER: 1MHz	Oscilloscope 2µs/DIV CH-A to TP8 dc coupled 1V/DIV TRIGGER:CH-A	High:0.8µs Period:6.4µs	
6'	same as 6 except CENTER: 990kHz	same as 6	High:0.8µs Period:7.2µs	
7	EXT REF: disconnected CENTER: 1MHz SPAN:0Hz	Oscilloscope 2µs/DIV CH-A to TP7 DC coupled 2V/DIV TRIGGER:CH-A	Level:2.5Vpp to 5Vpp Period 6.4µs	

Table A10-2. A10 Troubleshooting Data (3 of 3)

Step	HP4194A Settings	Measurement Setup	Main Parameters	Waveform
7'	same as 7 except CENTER: 990kHz	same as 7	Level:2.5Vpp to 5Vpp Period:7.2μs	
8	EXT REF: disconnected CENTER: 1MHz SPAN:0Hz	Oscilloscope 2μs/DIV CH-A to TP6 DC coupled 2V/DIV TRIGGER:CH-A	Duty: approx. 1% Period:6.4μs	
8'	same as 8 except CENTER: 990kHz	same as 8	Duty: approx. 1% Period:7.2μs	

AIO REFERENCE FREQUENCY GENERATOR

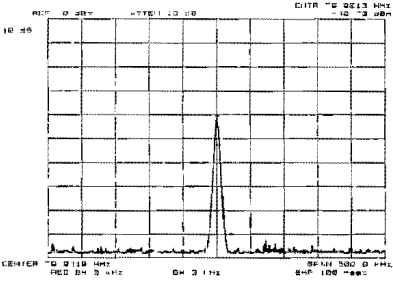
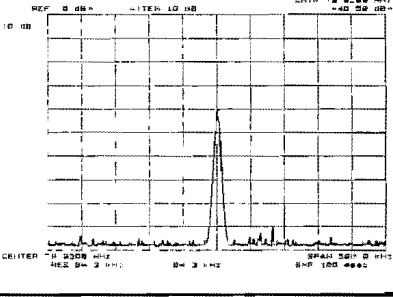
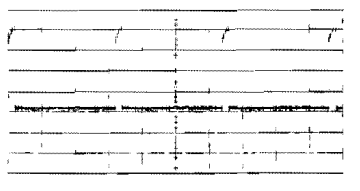
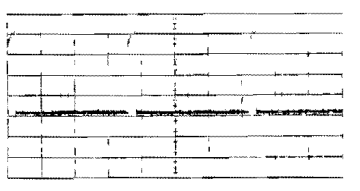
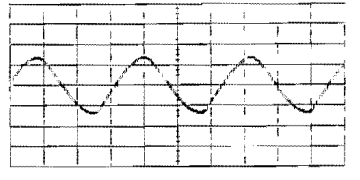
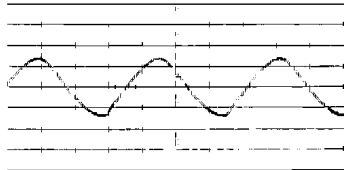
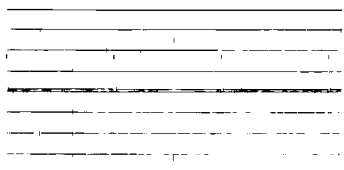
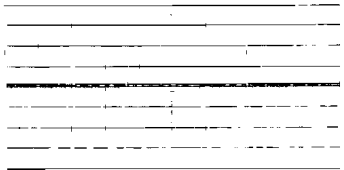
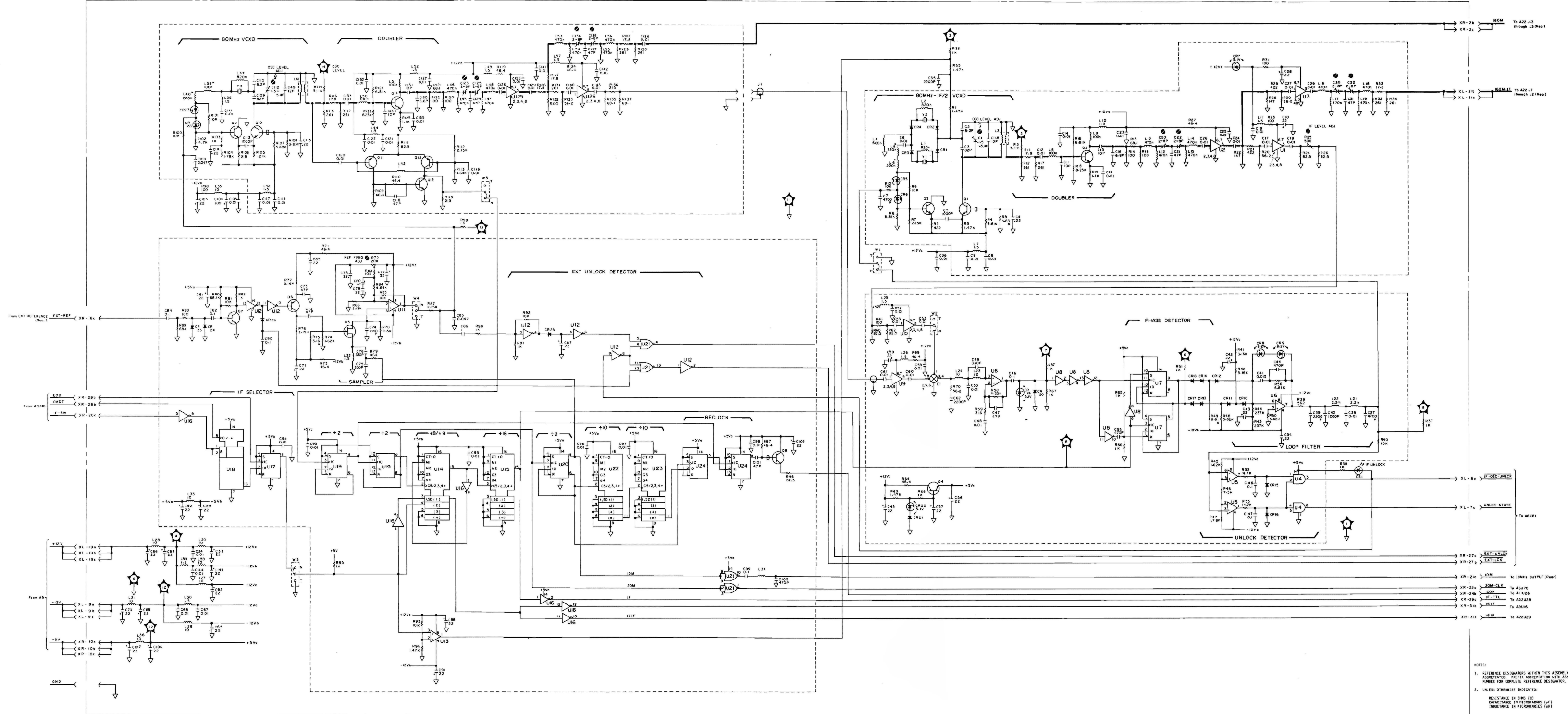

A10 Reference Frequency Generator Schematic Diagram

A11 Fractional N Loop Service Sheet

Figure A11-1 is a block diagram of the A11 Fractional N Loop board assembly. Included on the A11 board is a VCO, phase detector, API current source, integrator, frequency divider and the fractional N control logic. The VCO output frequency range is 160.00001MHz (for the 10Hz test signal) to 260MHz (for the 100MHz test signal).

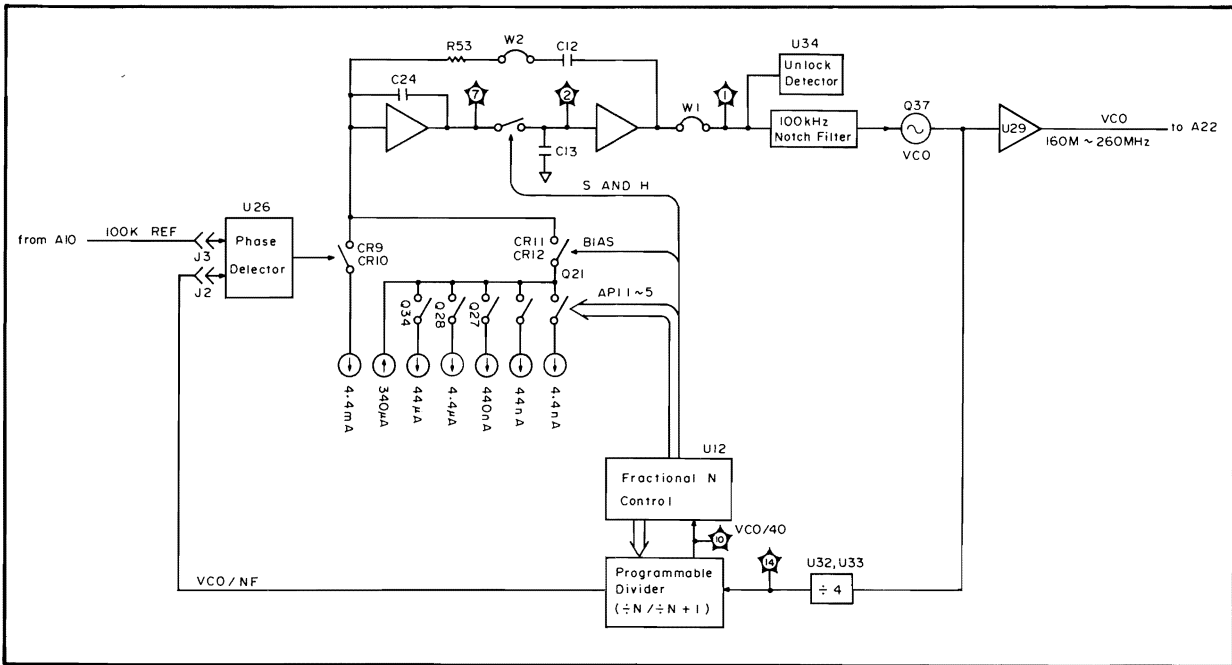

Figure A11-1. A11 Board Block Diagram

The theory of the Fractional N PLL circuit will be described first. Figure A11-2 shows a block diagram of a conventional PLL circuit, in which the phase difference between the reference signal and the divided VCO signal are very close to zero, and the frequencies are the same. A dc current source is added at the feedback node of the integrator in Figure A11-3. When the output of the current source is constant, the phase difference between the two signals is not zero but is constant so the frequency of the two signals will remain the same. If the the output of the current source increases at a constant rate, the phase difference will increase at a constant rate, causing a slight difference in frequency between the signals. Since the rate of increase for the increasing current is constant, the frequency difference will remain stable.

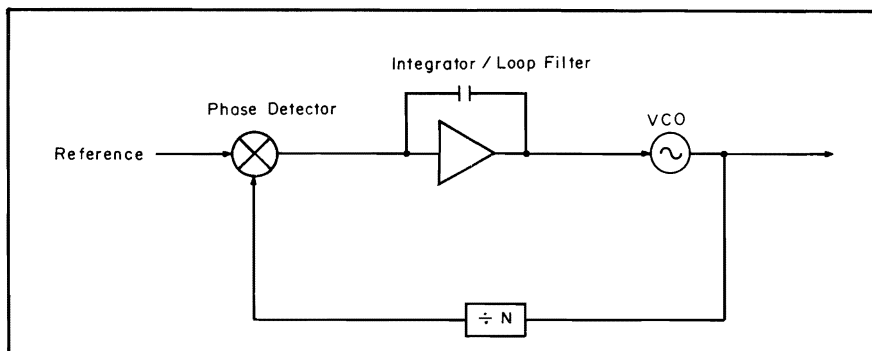

Figure A11-2. Conventional PLL Block Diagram

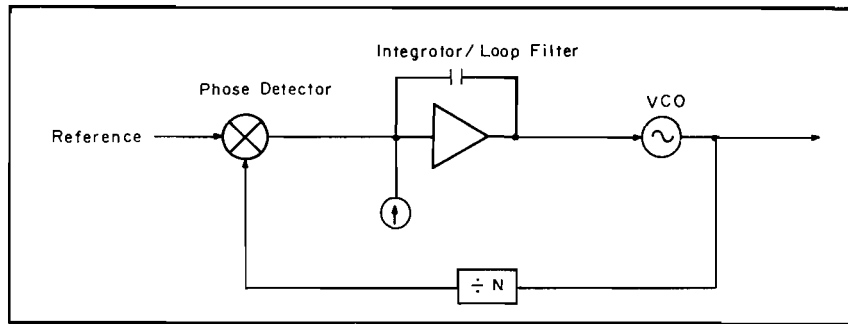

Figure A11-3. Variable Phase PLL with a Current Source

To apply this theory to the actual circuit, the variable current source is realized by using a five-decade range constant current source, a bias current source and a sample and hold (S/H) circuit. The total quantity of current injected to the summing node is controlled by the switching period of the five decade current sources. The five decade API (Analog Phase Interpolation) current sources are automatically controlled by the Fractional N Control Chip. When the phase difference between the two signals exceeds 360° , the divide by N counter increments once more, or it divides by N+1. This is called the Pulse Swallow Operation. If it were not for this operation, the maximum current of the API would have to be infinite. The pulse swallow operation is performed at a rate which is a function of the difference between the VCO frequency and an integer multiple of the Reference frequency. For example, when the VCO frequency is 200.000002MHz, the pulse swallow operation is performed twice per second.

Phase detector U26 compares the phase of the 100kHz reference signal from the A10 board and the VCO's output which is divided by a fractional number. The output of the phase detector switches the 4.4mA discharge current source on and off.

Transistor array U20 functions as a current sink. The current through Q32 is 4.4mA. The sink current through U20-8 and U20-11 is 2.2mA, respectively. During the bias period Q33 is on and the current through Q33 is 4.4mA, and if API-1 is low, Q34 is off, then the current through CR13 is 4.4mA. The current is split by the 100 Ω and 10k Ω resistors in resistor network R75, and the current through the 10k Ω resistor is 44 μ A. The resistance ratio between the 100 Ω and 10k Ω resistors should be exactly 1:100, so parallel resistors R56 and R77 are used to adjust the 100 Ω resistor to achieve a 1:100 ratio. In a similar manner the current through the 50k Ω resistor (R75) is 4.4 μ A, and the current through the 500k Ω resistor is 0.44 μ A. The D-API4 line controls the 44nA current and the D-API5 line controls the 4.4nA current. The current from the bias current source is approximately 340 μ A.

During the BIAS period, the remainder current is charged by the integrator, then during the period between the VCO/NF pulse and 100kHz reference pulse, CR9 is turned on to discharge the integrator. The integrator output is sampled at rate of 100kHz, the same as the reference frequency, and is held by the sample and hold circuit. The sample and hold's output voltage is amplified by a factor of 5 and is used as the control voltage for the VCO. The control voltage is monitored by U34, the VCO phase lock detector. U34 monitors the VCO's control voltage, not its output, therefore the phase lock information will not directly indicate if the PLL is locked, but will indicate if the control voltage is within the lock range. Figure A11-4 shows integrator output waveform and related timing.

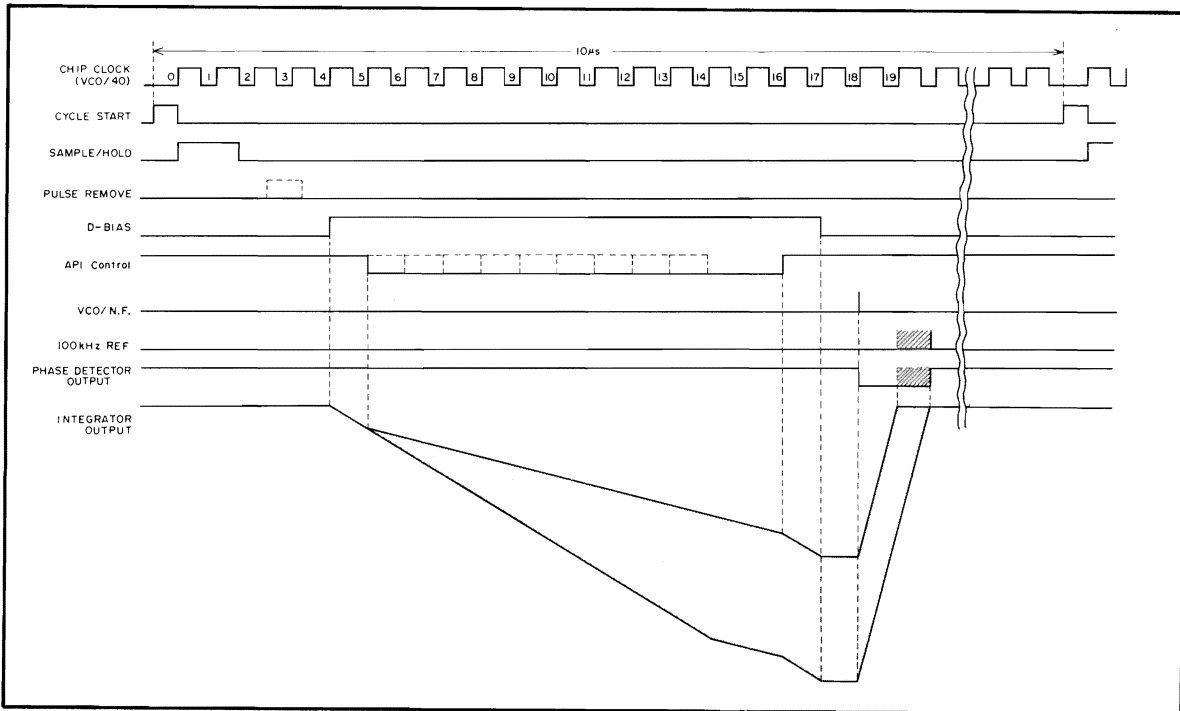

Figure A11-4. Fractional N Loop Timing Diagram

Table A11-1. A11 Troubleshooting Aids

Reference Designator	Description	Use
R1	VCO control voltage for VCO test	Change W1 to Test position and monitor the control voltage at TP1.
W1	VCO control voltage	N: Connected to the loop feed back voltage. T: Connected to R1 output voltage.
W2	×5 amplifier feed back path	Integrator, S/H and ×5 amplifier loop check.
W3	Feedthrough integration capacitor	W2 isolates ×5 amplifier output from the integrator input.
W4	Integrator output/sample and hold input	W3 changes the integrator to an amplifier. W4 isolates the S/H and ×5 amplifier from the loop.

Table A11-2. A11 Troubleshooting Data (1 of 3)



Step	HP4194A Settings	Measurement Setup	Main Parameters	Waveform
1	CENTER: 40MHz SPAN:0Hz	Oscilloscope 2 μ s/DIV CH-A to TP3 DC coupled 5V/DIV CH-B to TP7 DC coupled 0.2V/DIV TRIGGER:CH-A	Period:10 μ s	
2	CENTER: 40MHz SPAN:0Hz	Oscilloscope Main:10 μ s/DIV Delay:200ns/DIV CH-A to R101 DC coupled 2V/DIV CH-B to R124 DC coupled 2V/DIV TRIGGER:CH-A	Pulse height: >1V Time interval between the two signals: approx. 100ns	
3	CENTER:4MHz SPAN:0Hz If Fractional N Loop does'nt function properly, set A11W1 to Test and set VCO frequency to 164 MHz with A11R1.	Oscilloscope 10ns/DIV CH-A to TP14 DC coupled 1V/DIV CH-B to J1 on Control Unit rear panel. 50 Ω input 200mV/DIV TRIGGER:CH-A	Period:CH-A; CH-A:24ns CH-B:6ns Note: If you can't check ampl/ waveform with your o'scope, check frequency only.	
4	same as 3	Oscilloscope 20ns/DIV CH-A to TP14 DC coupled 1V/DIV CH-B to TP5 DC coupled 2V/DIV TRIGGER:CH-B	Period: CH-A:24ns CH-B:49ns CH-B:TTL level	
5	same as 3	Oscilloscope 50ns/DIV CH-A to TP14 DC coupled 2V/DIV CH-B to TP11 DC coupled 2V/DIV TRIGGER:CH-B	Period: CH-A:24ns CH-B:240ns	

Table A11-2. A11 Troubleshooting Data (2 of 3)

Step	HP4194A Settings	Measurement Setup	Main Parameters	Waveform
6	same as 3	Oscilloscope 2 μ s/DIV CH-A to TP11 DC coupled 2V/DIV CH-B to U23-14 DC coupled 2V/DIV TRIGGER:CH-A	divisor: 11 10 10 10	
7	same as 3	Oscilloscope 2 μ s/DIV CH-A to TP12 dc coupled 2V/DIV CH-B to U23-14 dc coupled 2V/DIV TRIGGER:CH-A		
8	same as 3	Oscilloscope Main:10 μ s/DIV Delay:100ns/DIV CH-A to TP12 DC coupled 2V/DIV CH-B to TP15 DC coupled 2V/DIV TRIGGER:CH-A	Time interval between the two signals. approx. 100ns	
9	same as 3	Oscilloscope 2 μ s/DIV CH-A to TP15 DC coupled 2V/DIV CH-B to TP17 DC coupled 2V/DIV TRIGGER:CH-A		
10	same as 3	Oscilloscope 50ns/DIV CH-A to TP14 DC coupled 2V/DIV CH-B to TP10 DC coupled 2V/DIV TRIGGER:CH-B		

Table A11-2. A11 Troubleshooting Data (3 of 3)

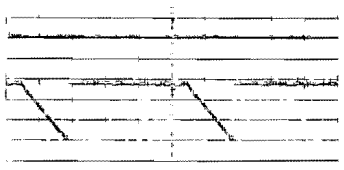
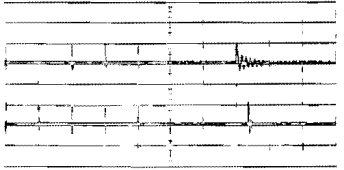
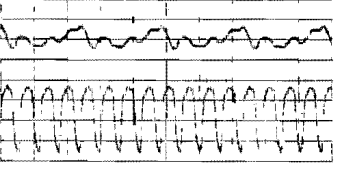
<p>11</p>	<p>÷N divisor check</p> <p>$N = (\text{CENTER Frequency} + 160\text{MHz})/400\text{kHz}$ the divisor data should be valid when TP12 signal goes LOW</p> <p>example: $N = 512$ when CENTER:44.8MHz (SPAN:0Hz)</p> <ul style="list-style-type: none"> → MSD of the divisor is 5 2SD of the divisor is 1 LSD of the divisor is 2 → 9's complement of 5 is 4 (= 9 - 5) 9's complement of 1 is 8 (= 9 - 1) 9's complement of 2 is 7 (= 9 - 2) → binary expression of 4 is 0100 binary expression of 8 is 1000 binary expression of 7 is 0100 → DN8-MSD (U23-9) is LOW (0) DN4-MSD (U23-10) is HIGH (1) DN2-MSD (U23-1) is LOW (0) DN1-MSD (U23-15) is LOW (0) DN8-2SD (U22-9) is HIGH (1) DN4-2SD (U22-10) is LOW (0) DN2-2SD (U22-1) is LOW (0) DN1-2SD (U22-15) is LOW (0) DN8-LSD (U18-8) is LOW (0) DN4-LSD (U18-11) is HIGH (1) DN2-LSD (U18-5) is HIGH (1) DN1-LSD (U9-2) is HIGH (1)
-----------	--

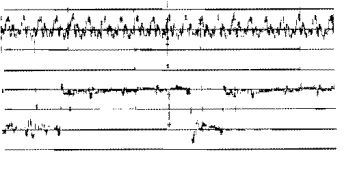

A11 FRACTIONAL N LOOP 1 of 2

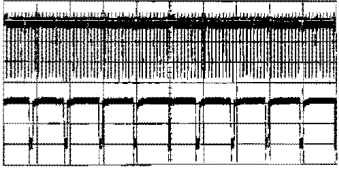
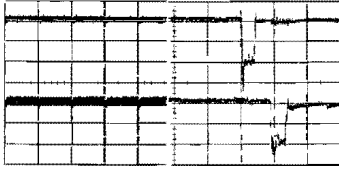
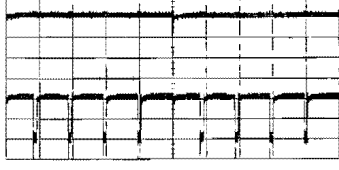
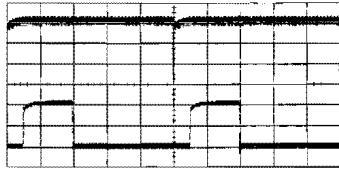
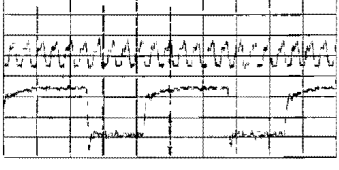
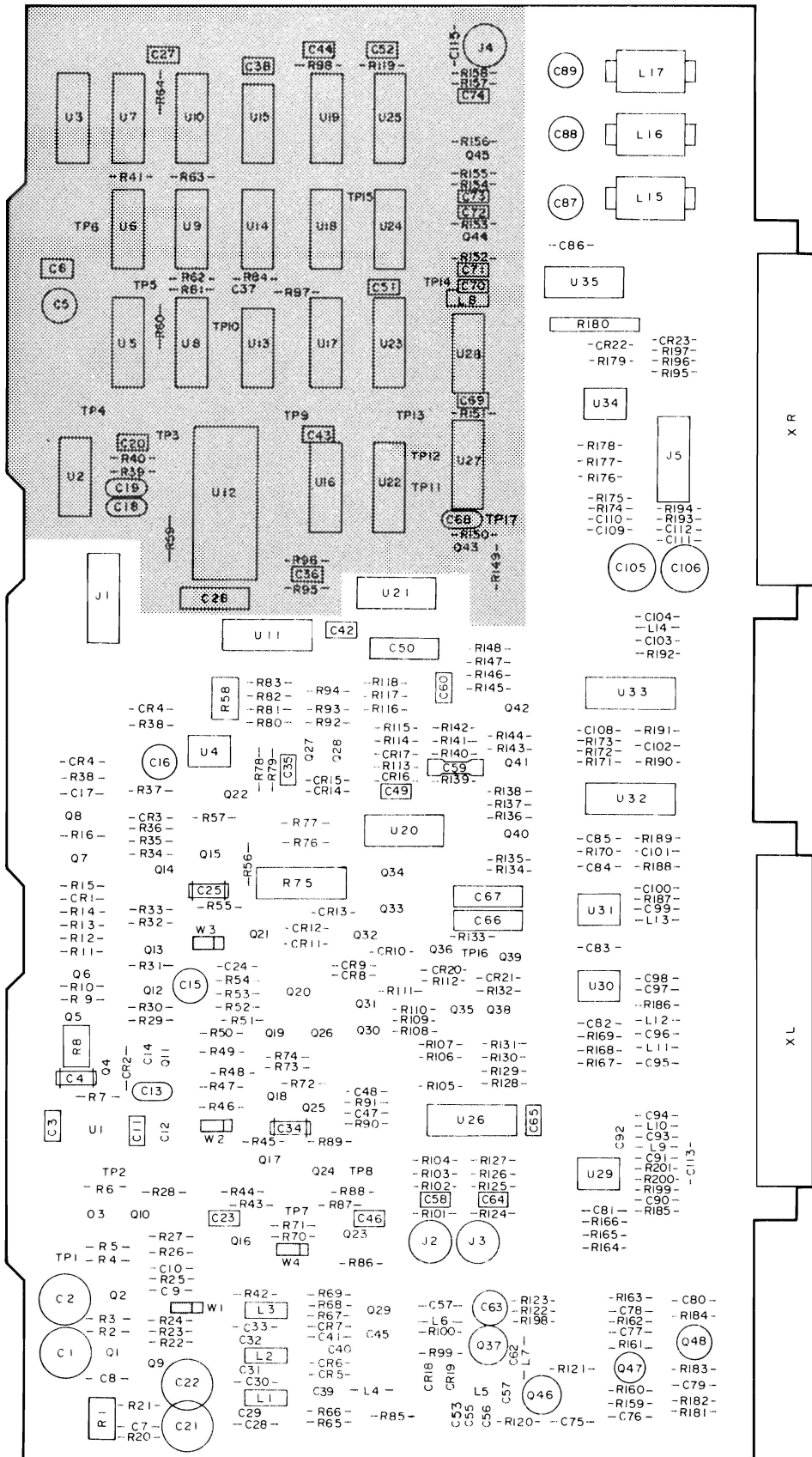
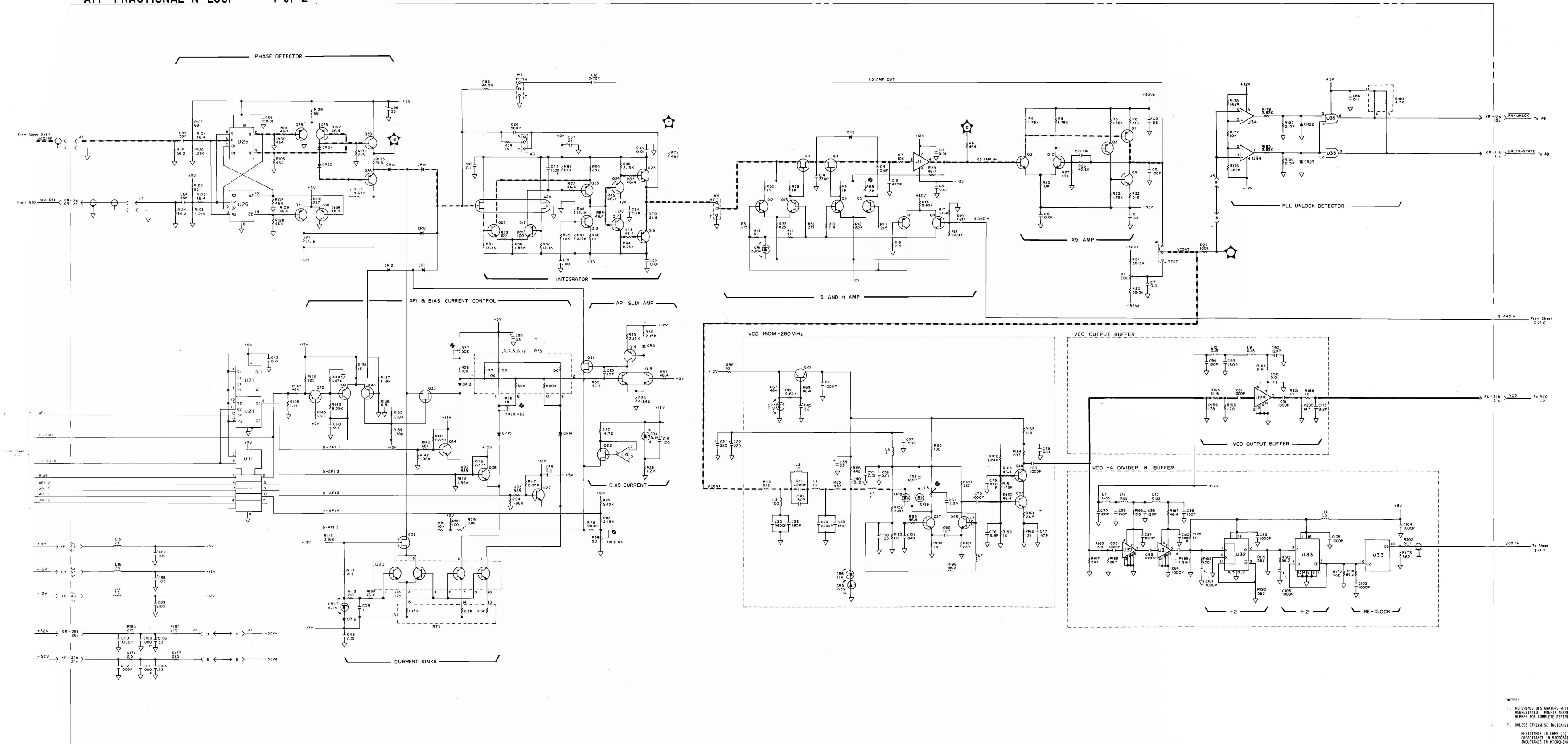

A11 Fractional N Loop Schematic Diagram (1 of 2)

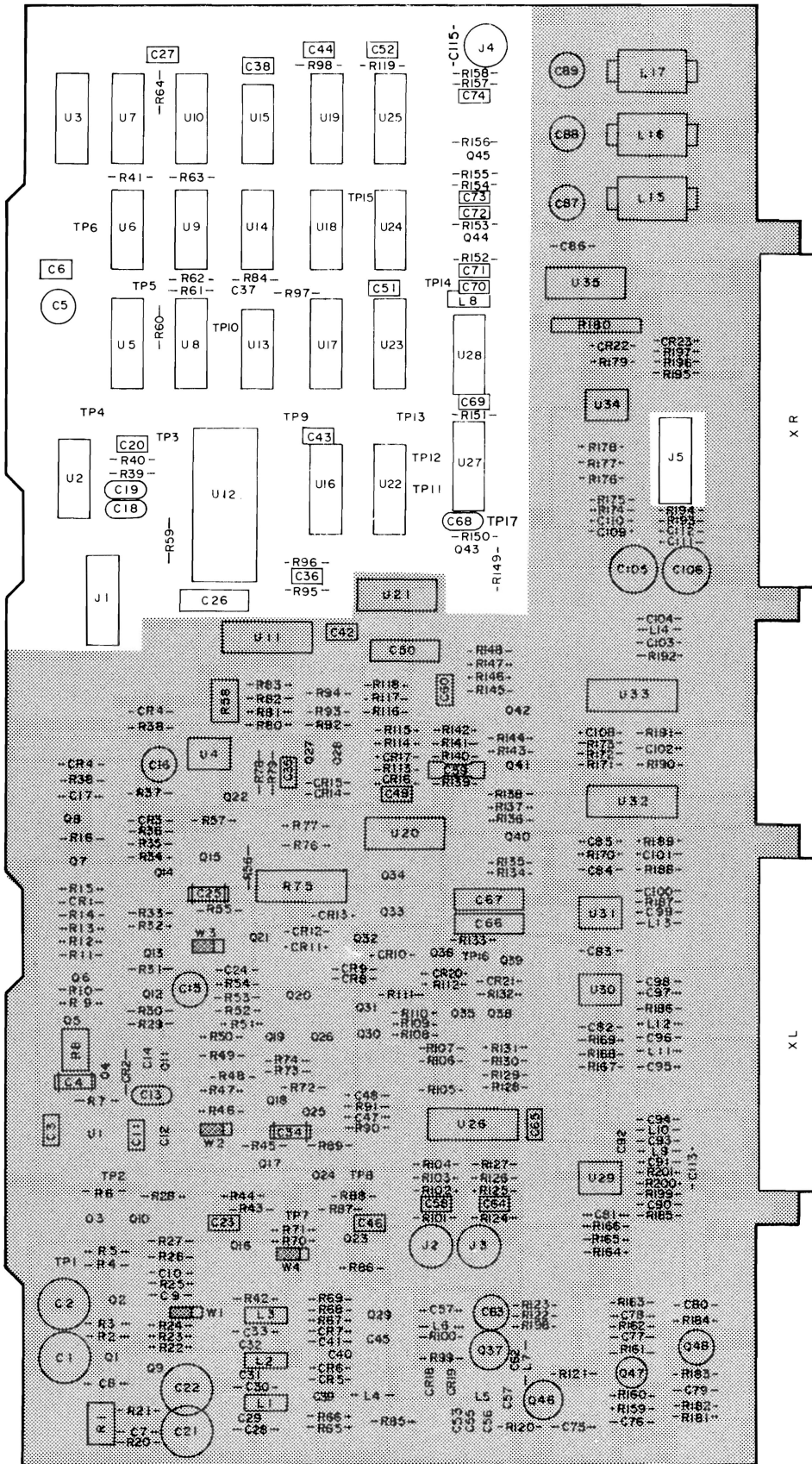

A11 Fractional N Loop Component Locations (2 of 2)
8-117

A11 FRACTIONAL N LOOP 2 of 2

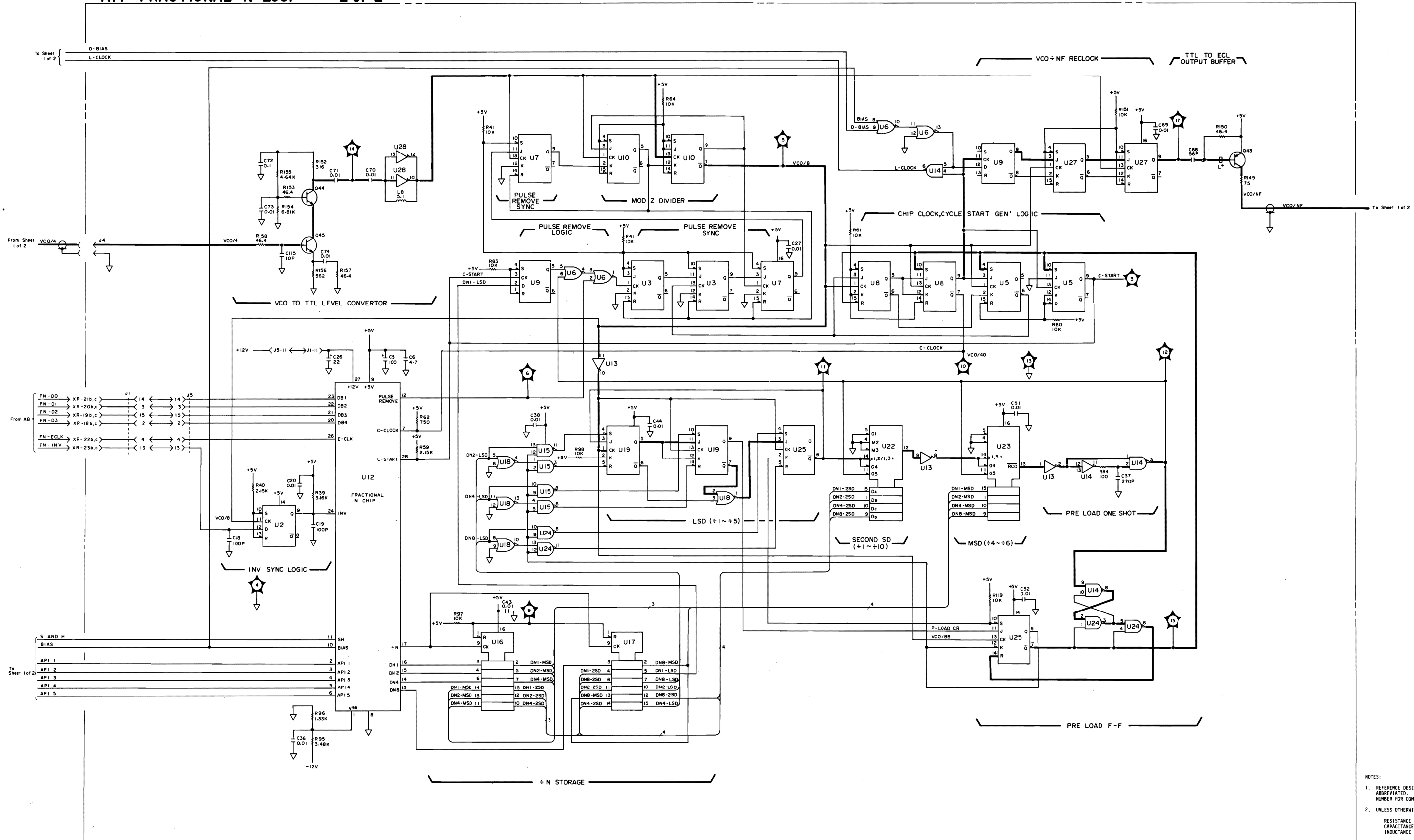

A11 Fractional N Loop Schematic Diagram (2 of 2)

A12/A13 Control Unit Keyboard Service Sheet

The control unit keyboard consists of A12 (Keyboard Control), and A13 (Control Unit Keyboard). Keys, LED indicators and a RPG (rotary pulse generator), are on A13. A12 interfaces A6 to A13.

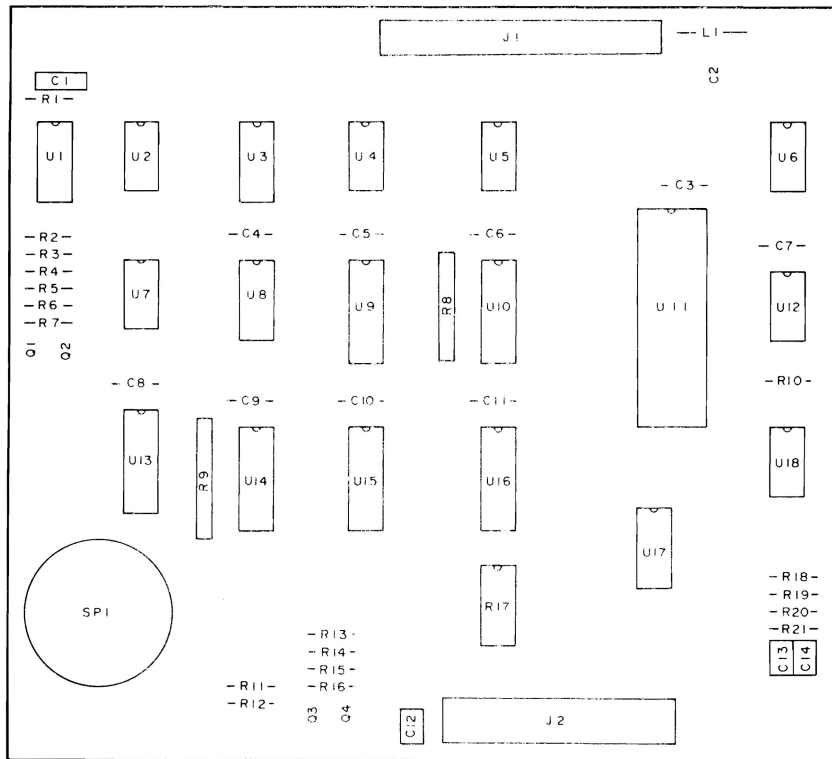

A12 Keyboard Control Component Locations

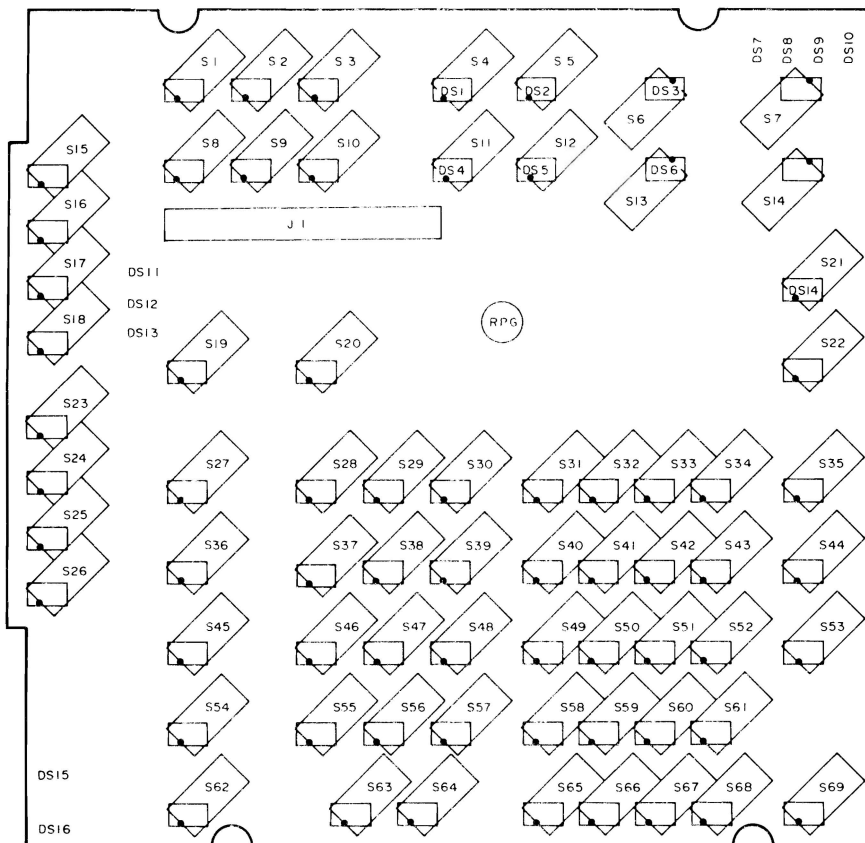

A13 Control Unit Keyboard Component Locations

A12 KEYBOARD CONTROL

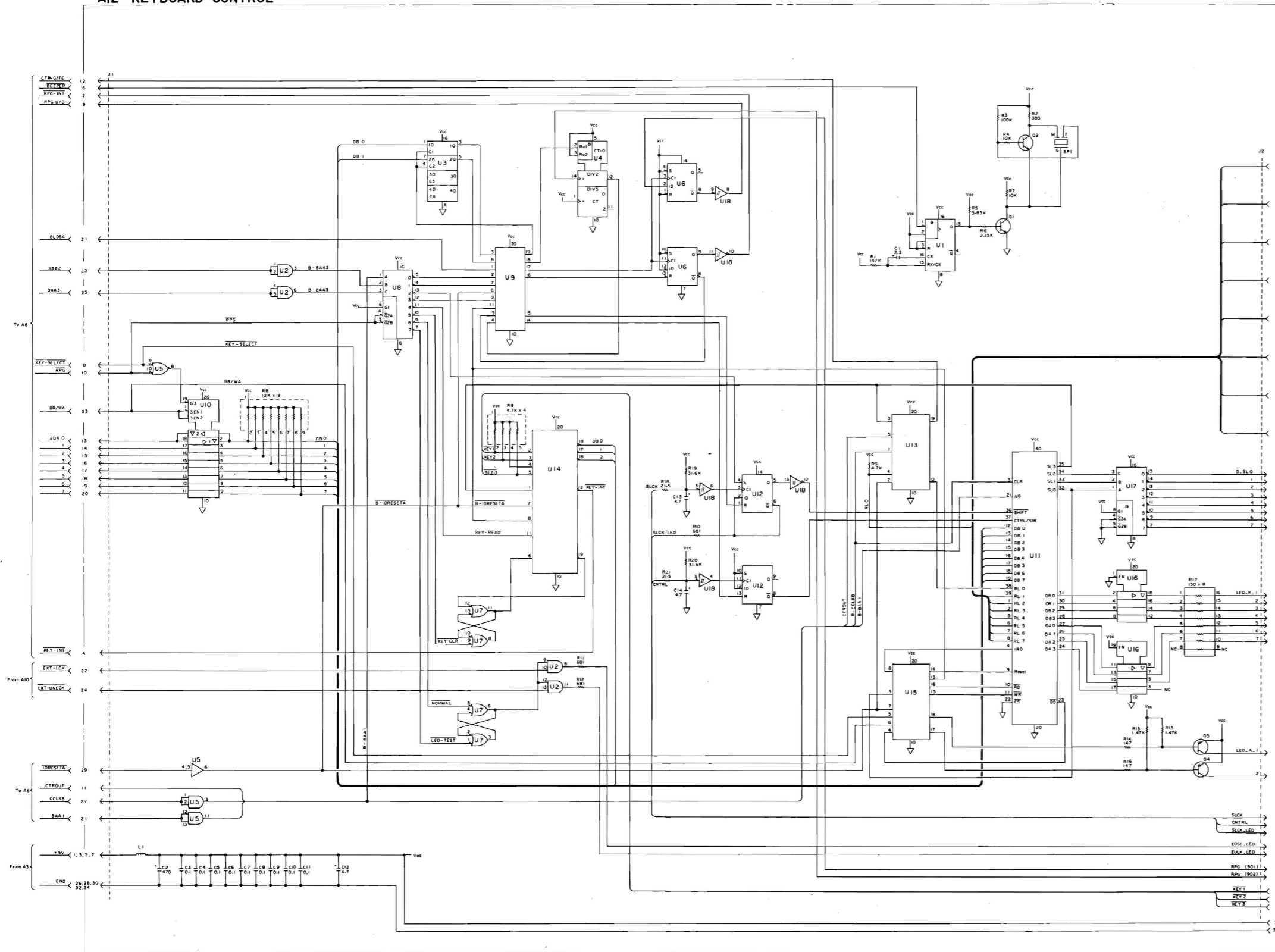

A13 CONTROL UNIT KEYBOARD

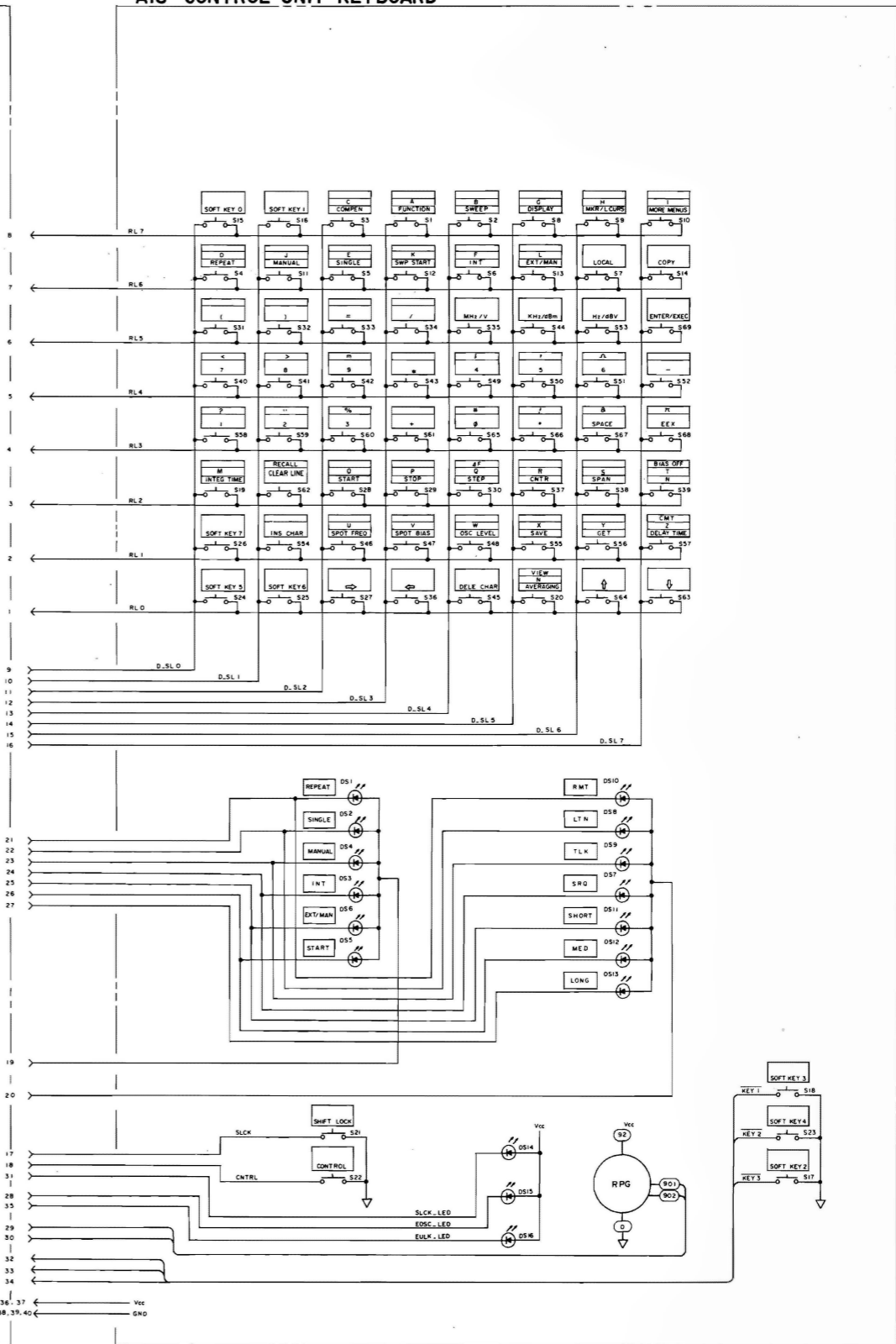

NOTES:
 1. REFERENCE DESIGNATORS WITHIN THIS ASSEMBLY ARE ABBREVIATED. PREFIX ABBREVIATION WITH ASSEMBLY NUMBER FOR COMPLETE REFERENCE DESIGNATOR.
 2. UNLESS OTHERWISE INDICATED:
 RESISTANCE IN OHMS (Ω)
 CAPACITANCE IN MICROFARADS (μF)
 INDUCTANCE IN MICROHENRIES (μH)

A12/A13 Control Unit Keyboard Schematic Diagrams

MEASUREMENT UNIT SERVICE SHEETS

- A20** **Range Resistor Service Sheet**

- A21/A31** **Process Amplifier Service Sheet**

- A22** **Modulator/Frequency Converter Service Sheet**

- A23** **Null Detector Service Sheet**

- A24/A34** **Output Amplifier Service Sheet**

- A25** **High Stability Oscillator Service Sheet**

- A26** **Measurement Unit Keyboard Service Sheet**

A20 Range Resistor Service Sheet

Figure A20-1 is the block diagram of the A20 Range Resistor board. This board includes the L_{CUR} Amplifier, I channel and V channel Sense Amplifiers, the LF and HF multiplexers, amplifiers and attenuators. Digital signals to/from the A21 and A25 boards are routed through the A20 board. The power supply voltages for the A21 and A25 boards are also routed through the A20 board.

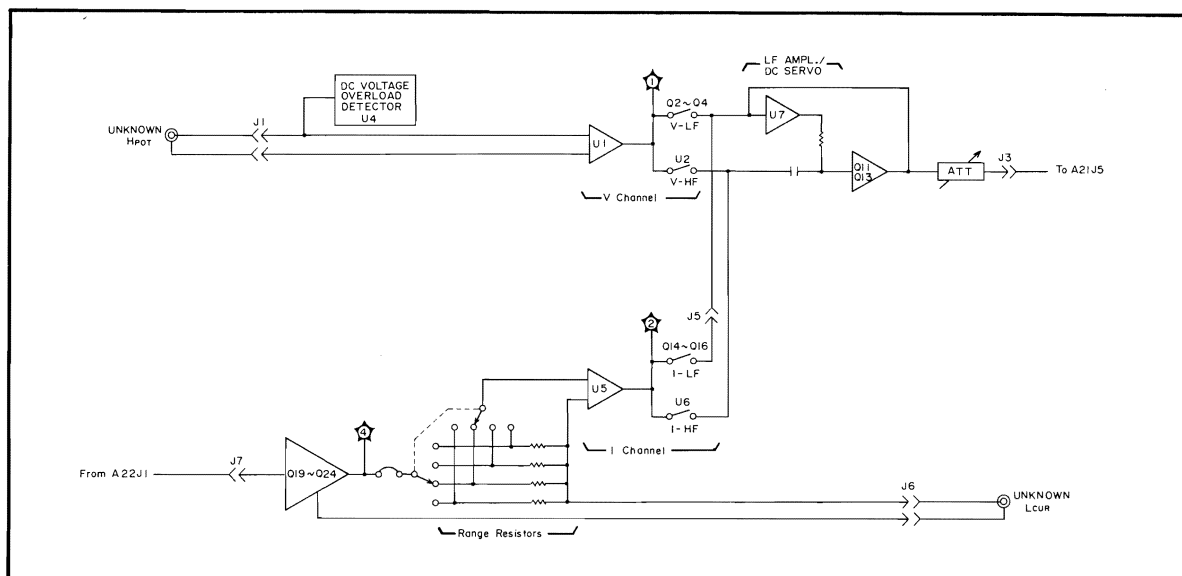

Figure A20-1. A20 Board Block Diagram

The Feedback signal from the auto-balance-bridge loop from A22J1 is amplified by the L_{CUR} Amplifier. The amplifier dc offset is auto zeroed by U25. The amplified signal goes through the 50 Ω , 400 Ω , 3.2k Ω , or 25k Ω range resistors. The 4194A does not have phase compensation capacitors in parallel with the range resistors as conventional Impedance Analyzers have. In the place of phase compensation capacitors, data stored in EEPROM is used to calculate the compensation factor.

Normally the 4194A does not have manual range selection, capability. To manually select the measurement range, set A8SW1-7 to **ON** and send a range control program code. The auto-range resistor selection is shown in Figure A20-2. The range control program codes can be sent from the 4194A's keyboard or via HP-IB. The codes are RZ0= auto range, RZ1= 50 Ω range, RZ2= 400 Ω range, RZ3= 3.2k Ω range, and RZ4= 25k Ω range. One of the range resistors is selected using one of the HIC switches, U20 through U23. One of the other HIC switches (U16 through U19), is used to measure the voltage across the range resistor. The current through the range resistor is connected to the UNKNOWN L_{CUR} terminal.

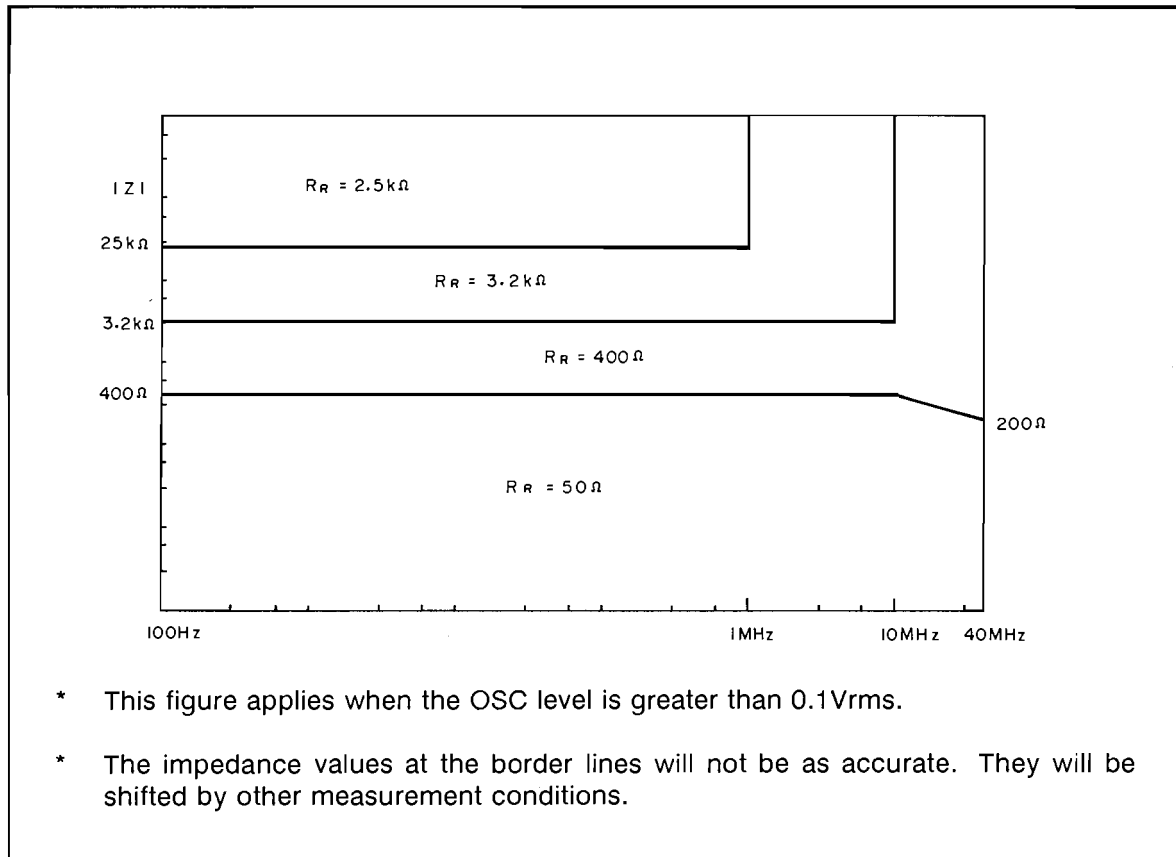

Figure A20-2. Range Resistor Selection

The I sense Amplifier is a HIC differential input buffer amplifier with a gain of approximately -10dB whose output voltage, when referenced to ground, is proportional to the voltage across the range resistor. U6 is the I channel multiplexer for the higher frequencies (30kHz to 40MHz), Q14, Q15, and Q16 are the I channel multiplexer for the lower frequencies (100Hz to 29.999999kHz).

The V channel Sense amplifier U1 is connected to the UNKNOWN H_{POT} terminal and is electrically the same as U5 but they are physically layed out as the mirror image of one another. Two comparators of U4 are used as DC Voltage Overload Detectors. If the voltage applied to the UNKNOWN H_{POT} terminal exceeds approximately $\pm 45V$, the DC-V-OVLD signal will go low. Q1 is the transient dc current absorber switch. U2 is the V channel multiplexer for high frequencies, the same type HIC as U6, and Q2, Q3, Q4 are used as the V channel multiplexer for low frequencies the same as Q14, Q15, and Q16.

U7 works as the LF amplifier when the test frequency is lower than 30kHz, and acts as a dc servo to hold the dc offset of Q13's output to zero when the test frequency is greater than 30kHz. The control of the attenuators depends on the OSC LEVEL setting. Refer to Table A20-1.

Table A20-1. OSC Level versus Attenuator Setting

For Option 350

OSC Level	3.3dB	6.7dB	13.3dB	total
9.7dBm to 13.0dBm	off	on	on	20.0dB
6.3dBm to 9.6dBm	on	off	on	16.6dB
3.0dBm to 6.2dBm	off	off	on	13.3dB
-0.3dBm to 2.9dBm	on	on	off	10.0dB
-3.7dBm to -0.4dBm	off	on	off	6.7dB
-7.0dBm to -3.8dBm	on	off	off	3.3dB
-27.0dBm to -7.1dBm	off	off	off	0dB

For Option 375

OSC Level	3.3dB	6.7dB	13.3dB	total
7.9dBm to 11.2dBm	off	on	on	20.0dB
4.6dBm to 7.8dBm	on	off	on	16.6dB
1.2dBm to 4.5dBm	off	off	on	13.3dB
-2.1dBm to 1.1dBm	on	on	off	10.0dB
-5.4dBm to -2.2dBm	off	on	off	6.7dB
-8.8dBm to -5.5dBm	on	off	off	3.3dB
-28.8dBm to -8.9dBm	off	off	off	0dB

Table A20-2. A20 Troubleshooting Aids

4194A Settings	Description
AVERAGING set to 1, TRIGGER set to >2	Multiplexers set to I channel.
AVERAGING set to >2, TRIGGER set to EXT/MAN.	Multiplexers set to V channel.

Table A20-3. A20 Troubleshooting Data

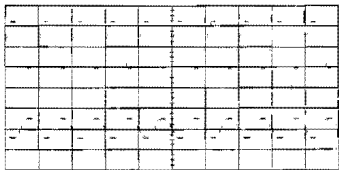
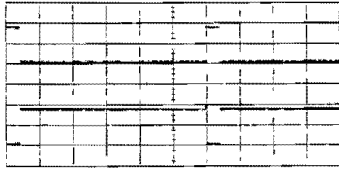
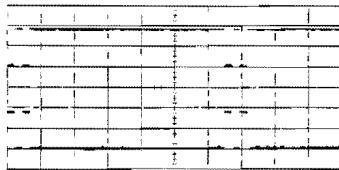
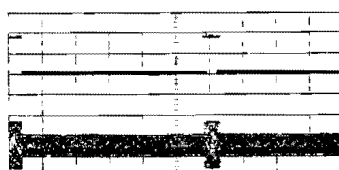
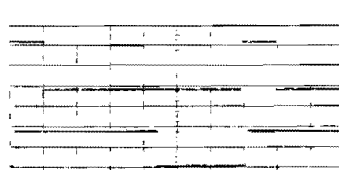
Step	HP 4194A Settings	Measurement Setup	Main Parameters	Waveform
1	CENTER:0Hz SPAN:0Hz DUT:1kΩ resistor	Oscilloscope 10μs/DIV CH-A to TP1 DC coupled 0.2V/DIV CH-B to TP2 DC coupled 0.2V/DIV TRIGGER:CH-A		
2	CENTER: 100kHz SPAN:0Hz SWEEP MODE: MANUAL	Oscilloscope 5ms/DIV CH-A to TP8 dc coupled 2V/DIV CH-B to TP9 DC coupled 2V/DIV TRIGGER:CH-A		
2'	same as 2 except AVERAGING:2	same as 2 except TRIGGER:CH-B		
3	CENTER: 100kHz SPAN:0Hz SWEEP MODE: AVERAGING:1 DUT:1kΩ resistor	Oscilloscope 5ms/DIV CH-A to TP8 dc coupled 2V/DIV CH-B to Q13 emitter DC coupled 0.2V/DIV TRIGGER:CH-A		
4	SWEEP: DC BIAS (V) STOP:10V	Oscilloscope 0.5ms/DIV CH-A to TP5 DC coupled 10V/DIV CH-B to TP8 DC coupled 2V/DIV TRIGGER:CH-A		

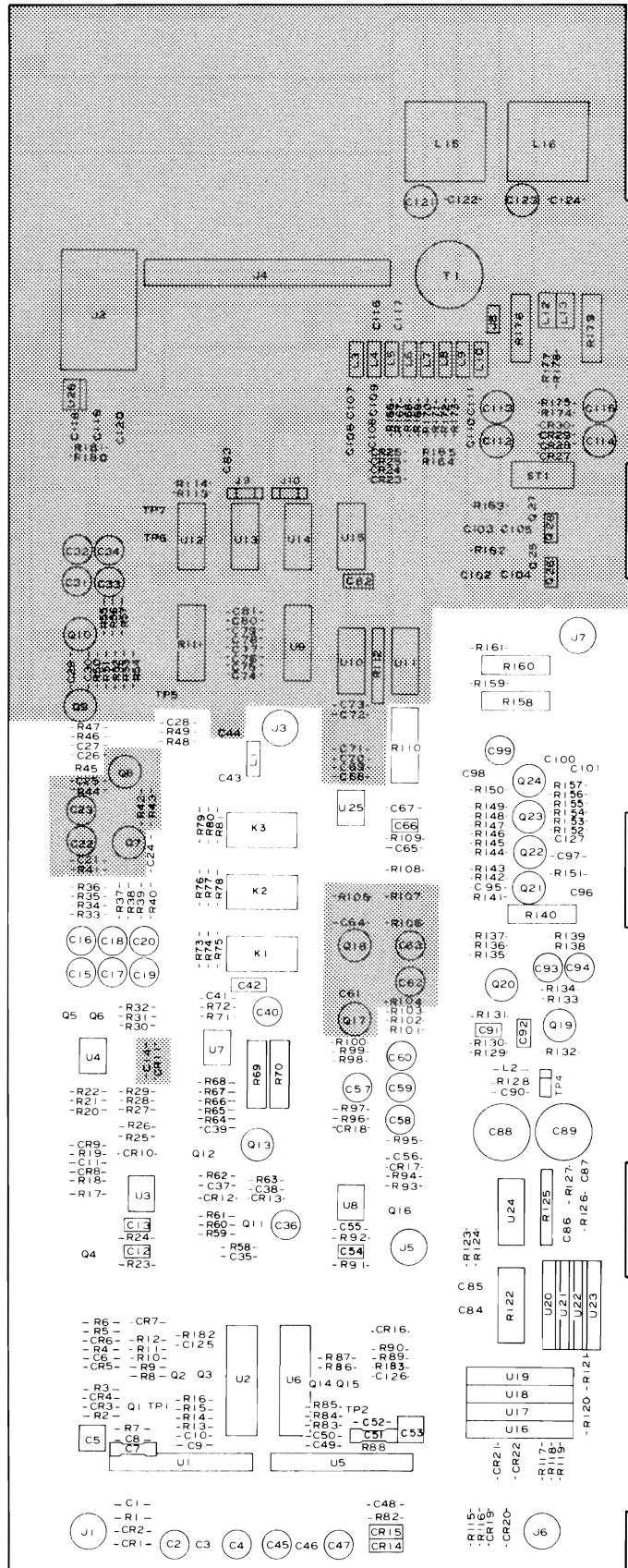

A20 Range Resistor Component Locations (1 of 2)

A20 RANGE RESISTORS 1 of 2

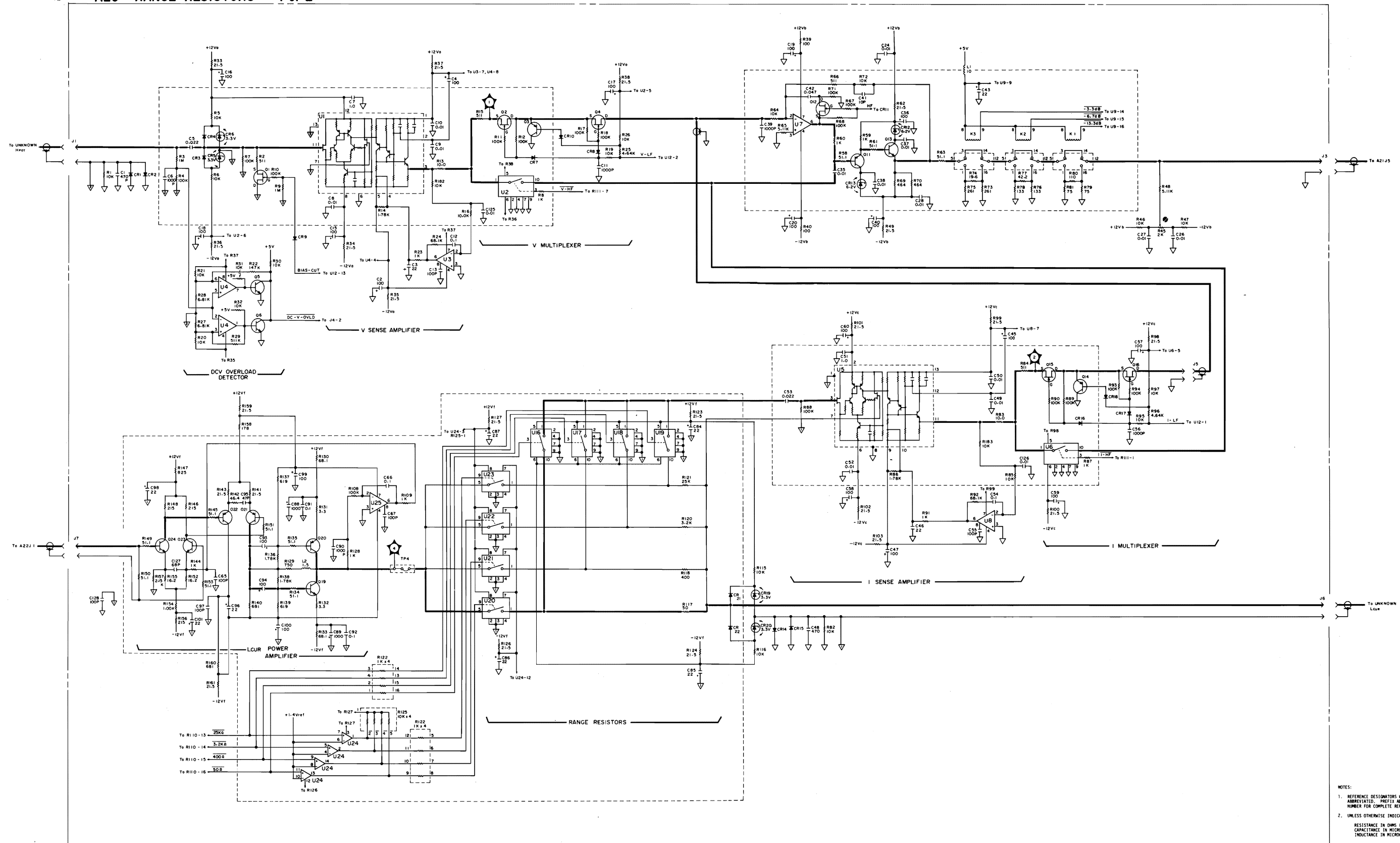

A20 Range Resistor Schematic Diagram (1 of 2)

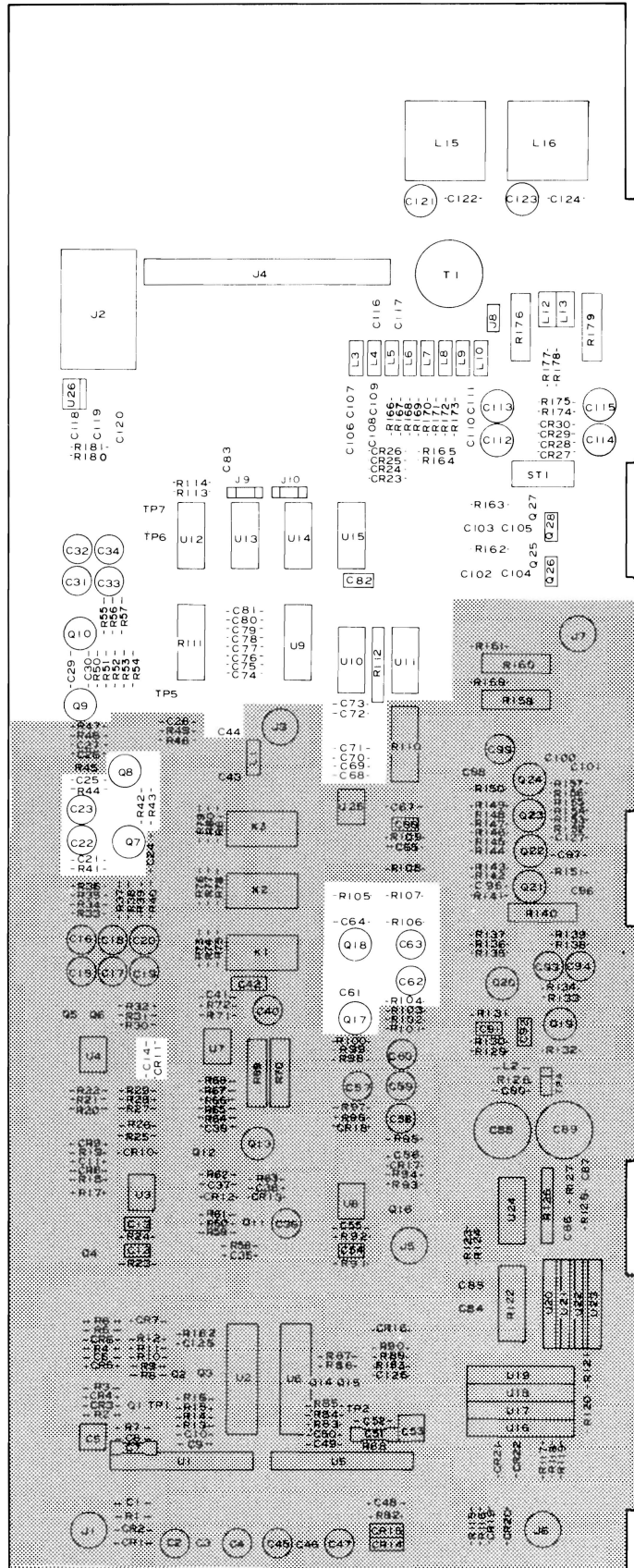

A20 Range Resistor Component Locations (2 of 2)
8-125

A20 RANGE RESISTOR 2 of 2

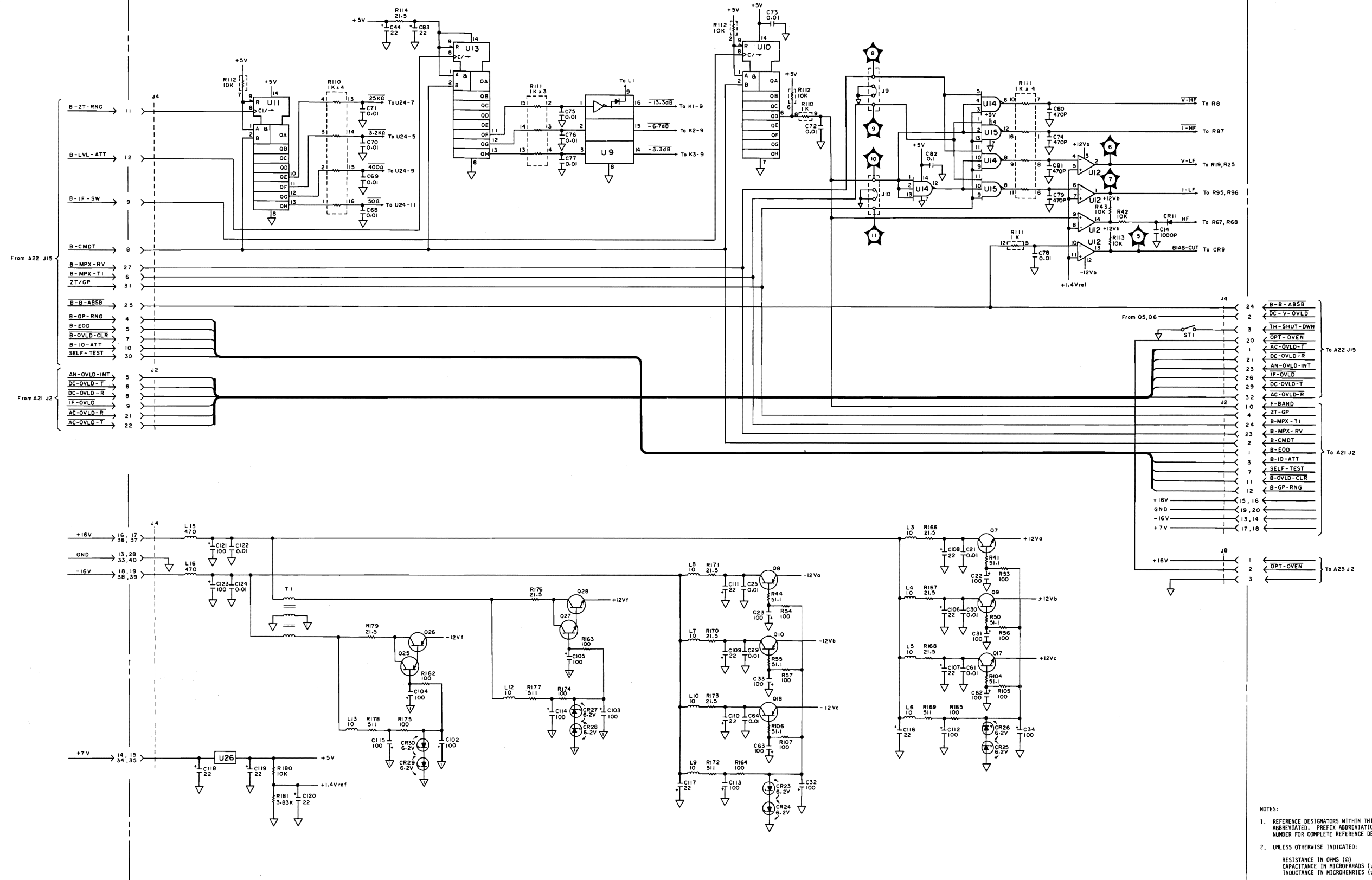

A20 Range Resistor Schematic Diagram (2 of 2)

A21/A31 Process Amplifier Service Sheet

Figure A21-1 is a block diagram of A21/A31 Process Amplifier board. This board is designated as A21 for 4194As with Option 350 and as A31 with Option 375. This board includes two gain-phase input channel amplifier/attenuator subassemblies, multiplexers to select input signals from the subassemblies, a relay to select the signal depending on the measurement function (impedance or gain-phase), IF converter and amplifiers/attenuators to adjust the signal level appropriate for the A-D converter on the A9 board. The main board of A21 and A31 is the same. Subassemblies A21A1 and A21A2 are for 50Ω systems, and A31A1 and A31A2 for 75Ω systems. Subassemblies A1 and A2 are electrically the same but are physically layed out as the mirror images of one another.

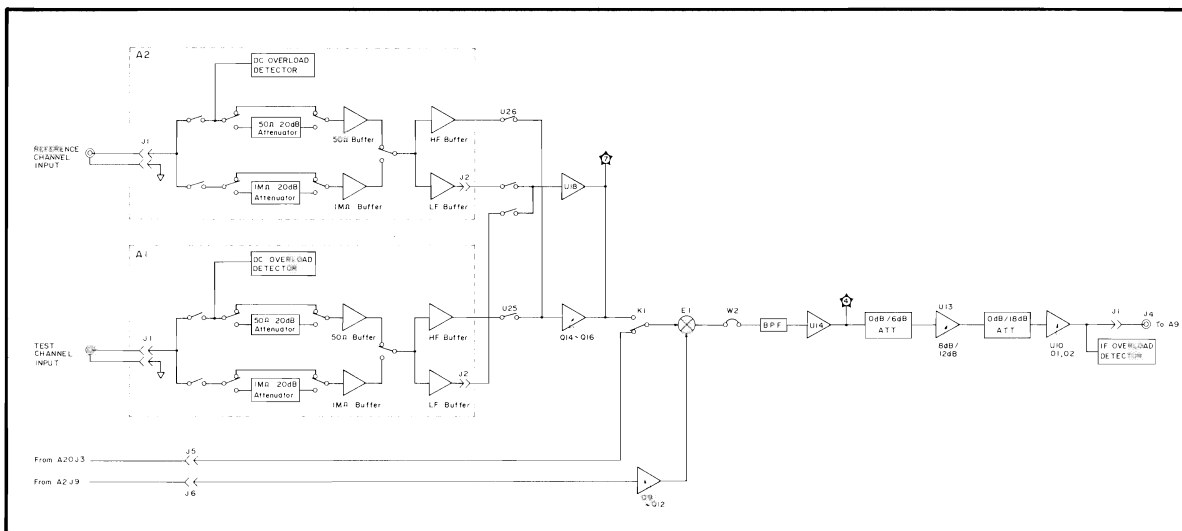

Figure A21-1. A21/A31 Board Block Diagram

The A21A1 Test channel will be used for the subassembly circuit description, as the two subassemblies are basically the same. Relay A1K4 and A1K5 are used to select an input impedance of 50Ω or 1MΩ. A1C43 is used to isolate dc voltage from the 1MΩ attenuator. A1K2 selects an INPUT ATTENUATION of 50Ω input and A1K3 selects 1MΩ. A1U3 detects if a dc voltage is applied to the 50Ω input at the BNC INPUT connector is greater than approximately ±3.5V or not and generates the DC-OVL D signal when dc voltage exceeds the threshold. A1Q3 is the 50Ω input buffer and A1Q4 and A1Q2 are the 1MΩ input buffers. A1Q1 is a HF buffer used to amplify input signals higher than 30kHz, and A1U2 is a LF buffer used to amplify input signals lower than 29.999999kHz.

Q21 through Q24 work as the LF REFERENCE channel multiplexer, Q17 through Q20 work as the LF TEST channel multiplexer, U25 is a HF TEST channel multiplexer and U26 is the HF REFERENCE channel multiplexer. U25 and U26 are mounted on the bottom side of the A21 (A31) board.

U18 is a LF buffer and dc offset controller used to adjust dc offset of the gain-phase measurement signal in order to minimize the local signal feedthrough from the mixer's output. Q14 through Q16 work as a HF buffer. Relay K1 selects the measurement function, Impedance or Gain-Phase. When K1 selects the impedance measurement function, the gain-phase measurement signal can be observed at J4 in order to troubleshoot the input amplifiers and attenuators. The selected signal is mixed down to the IF frequency by mixer E1. Q9 through Q12 are the local signal driver for the mixer. The converted IF signal is filtered by the IF Band Pass Filter, which also acts as a notch filter to reject the third harmonics of the IF (468.75kHz and 416.67kHz). R33, R34, Q6 and Q7 make up the 0dB/6dB selectable attenuator. When the frequency of the test signal is less than 30kHz, this attenuator is set to -6dB, and when the frequency is greater than 29.999999kHz, it is set to 0dB.

U13 is an amplifier with a selectable gain of 8dB/12dB. The gain is set to 12dB when **Impedance** is the selected measurement function, and is set to 8dB when **Gain-Phase** is the selected measurement function. Q3 or Q4 sets the attenuation setting of the attenuator, located between U13 and U10, to 0dB or 18dB. The gain of the amplifier constructed using U10, Q1 and Q2 is 14dB. U9 is the IF overload detector.

Table A21-1. A21 (A31) Troubleshooting Aids (1 of 2)

Reference Designator	Description	Use
J3	IF input connector to test and adjust the IF process amplifier.	Change W2 to Test position and input IF signal to J3.
J4	Gain-Phase measurement multiplexed signal output connector.	Remove W3 and monitor at J4 to check input amplifiers and multiplexers.
W1	0dB/18dB attenuator control	N: Either Q3 or Q4 turns on depending on IF signal amplitude. T: A4 is turned on. The attenuation is set to 18dB. Open: Q3 is turned on. The attenuation is set to 0dB.
W2	IF process amplifier input selector	N: Connects multiplexed IF signal. T: Connects to J3 input.
W3	Function (Impedance/Gain-Phase) select relay (K1) control.	N: K1 control depends on the selected function. T: K1 is set to Gain-Phase measurement. Open: K1 is set to Impedance measurement and the Gain-Phase measurement signal is output to J4 for testing.

Table A21-1. A21 (A31) Troubleshooting Aids (2 of 2)

4194A Settings	Description
AVERAGING set to 1, TRIGGER set to EXT/MAN	Multiplexers set to Test channel.
AVERAGING set to >2, TRIGGER set to EXT/MAN	Multiplexers set to Reference channel.

Table A21-2. A21 (A31) Troubleshooting Data (1 of 3)



Step	HP 4194A Settings	Measurement Setup	Main Parameters	Waveform
1	FUNCTION: GAIN-PHASE CENTER: 1kHz SPAN:0Hz DUT: 10dB ATT	Oscilloscope 0.5ms/DIV CH-A to A21A1TP1 DC coupled 0.5V/DIV CH-B to A21A2TP1 DC coupled 0.5V/DIV TRIGGER:CH-A	Amplitude CH-A:approx. 0.4Vpp CH-B:approx. 1.4Vpp	
2	FUNCTION: GAIN-PHASE CENTER: 10MHz SPAN:0Hz TRIGGER: EXT/MAN DUT: 10dB ATT	Oscilloscope 50ns/DIV CH-A to A21A1J10 DC coupled 100mV/DIV CH-B to A21A2J3 DC coupled 100mV/DIV TRIGGER:CH-B	Negative dc offset on CH-A	
3	CENTER: 10MHz SPAN:0Hz INTEG TIME: MED DUT: 10dB ATT	Oscilloscope 5ms/DIV CH-A to A21A1J10 DC coupled 100mV/DIV CH-B to A21A1J3 DC coupled 100mV/DIV TRIGGER:CH-A		
4	FUNCTION: GAIN-PHASE INTEG TIME: MED CENTER:1kHz 1kHz SPAN:0Hz DUT: 10dB ATT	Oscilloscope 5ms/DIV CH-A TO TP7 DC coupled 0.5V/DIV CH-B to L11 DC coupled 5V/DIV TRIGGER:CH-B		
5	FUNCTION: GAIN-PHASE INTEG TIME: MED CENTER: 10MHz SPAN:0Hz A21W3:OPEN DUT: 10dB ATT	Oscilloscope 5ms/DIV CH-A to J4 50Ω 20mV/DIV CH-B TO TP8 DC coupled 5V/DIV TRIGGER:CH-B		

Table A21-2. A21 (A31) Troubleshooting Data (2 of 3)

Step	HP 4194A Settings	Measurement Setup	Main Parameters	Waveform
6	same as 5 except INTEG TIME: SHORT	same as 5 except TIME BASE: 0 5ms/DIV		
7	CENTER: 1kHz SPAN:0Hz	Oscilloscope 2μs/DIV CH-A TO E1-8 (right-hand lead of C52) DC coupled 0.1V/DIV TRIGGER:CH-A		
8	CENTER: 10MHz SPAN:0Hz	same as 7 except TIME BASE: 50ns/DIV		
9	FUNCTION GAIN-PHASE CENTER: 1kHz SPAN:0Hz INTEG TIME: MED DUT: 10dB ATT	Oscilloscope 5ms/DIV CH-A to TP1 DC coupled 1V/DIV CH-B to L11 DC coupled 5V/DIV TRIGGER:CH-B		
10	same as 9	Oscilloscope 0.2ms/DIV CH-A to TP1 DC coupled 1V/DIV CH-B to A21A2TP1 DC coupled 0.5V/DIV TRIGGER:CH-B		

Table A21-2. A214 (A214) Troubleshooting Data (3 of 3)

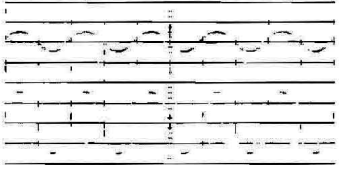
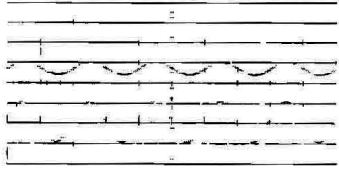
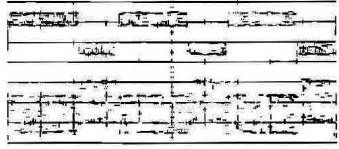
Step	HP 4194A Settings	Measurement Setup	Main Parameters	Waveform
11	same as 9	Oscilloscope 2 μ s/DIV CH-A to TP1 DC coupled 0.5/DIV TRIGGER:CH-A		
12	FUNCTION: GAIN-PHASE CENTER: 10MHz SPAN:0Hz INTEG TIME: MED DUT: 10dB	Oscilloscope 5ms/DIV CH-A to TP1 DC coupled 1V/DIV CH-B to TP8 DC coupled 5V/DIV TRIGGER:CH-B		
13	same as 12	Oscilloscope 2 μ s/DIV CH-A to TP1 DC coupled 0.5V/DIV TRIGGER:CH-A		

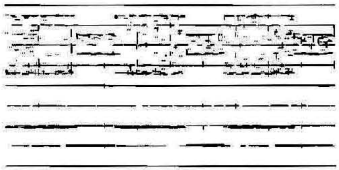
A21 (A31) Process Amplifier Component Locations
8-133

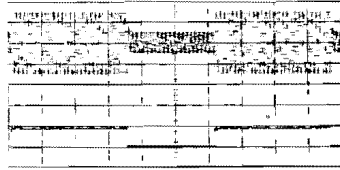
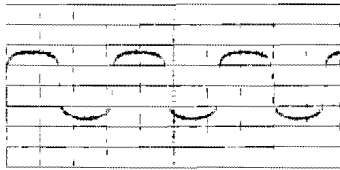
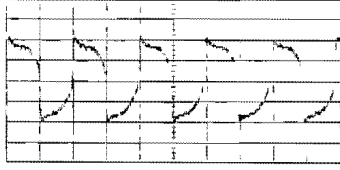
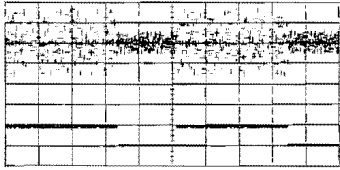
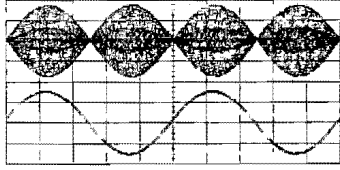
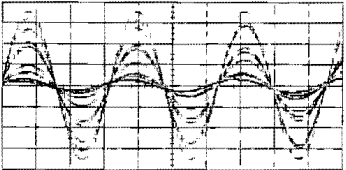
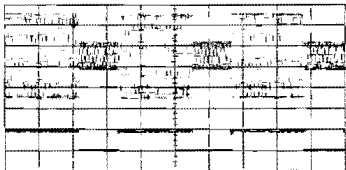
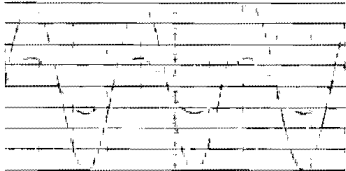
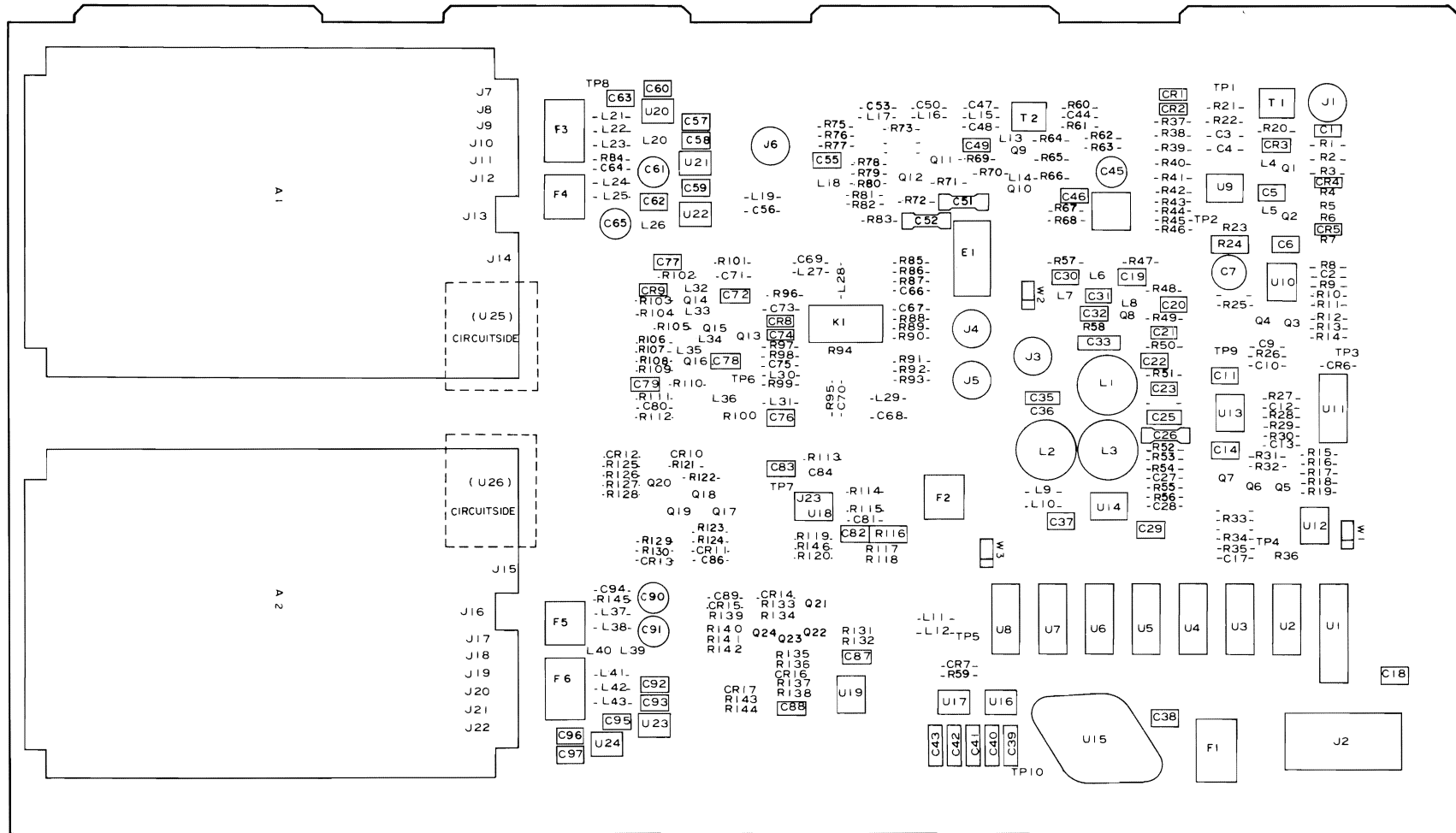

A21/A31 PROCESS AMPLIFIER

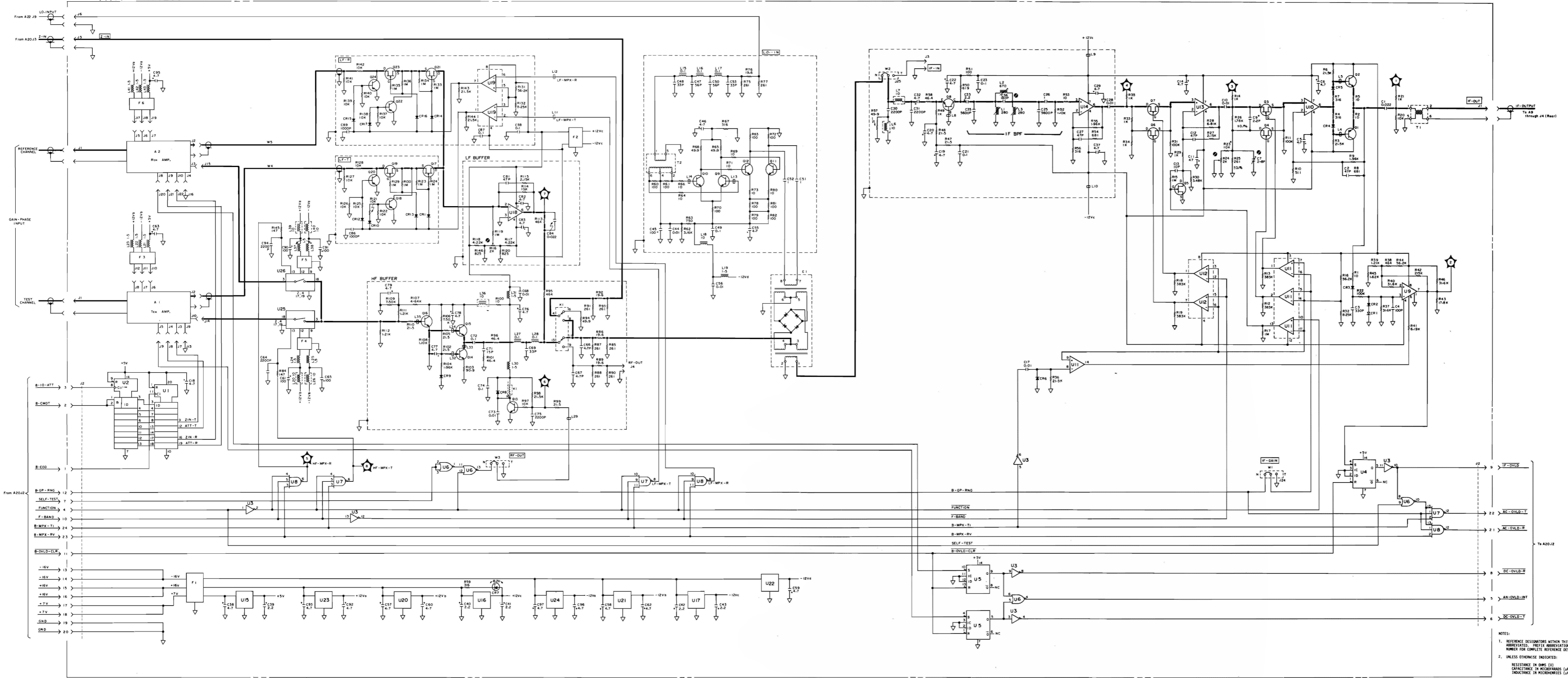

NOTES:
1. REFERENCE DESIGNATORS WITHIN THIS ASSEMBLY ARE ABBREVIATED. PREFIX ABBREVIATION WITH ASSEMBLY NUMBER FOR COMPLETE REFERENCE DESIGNATION.
2. UNLESS OTHERWISE INDICATED:
RESISTANCE IN OHMS (Ω)
CAPACITANCE IN MICROFARADS (μF)
INDUCTANCE IN MICROHENRIES (μH)

A21/A31 Process Amplifier Schematic Diagram

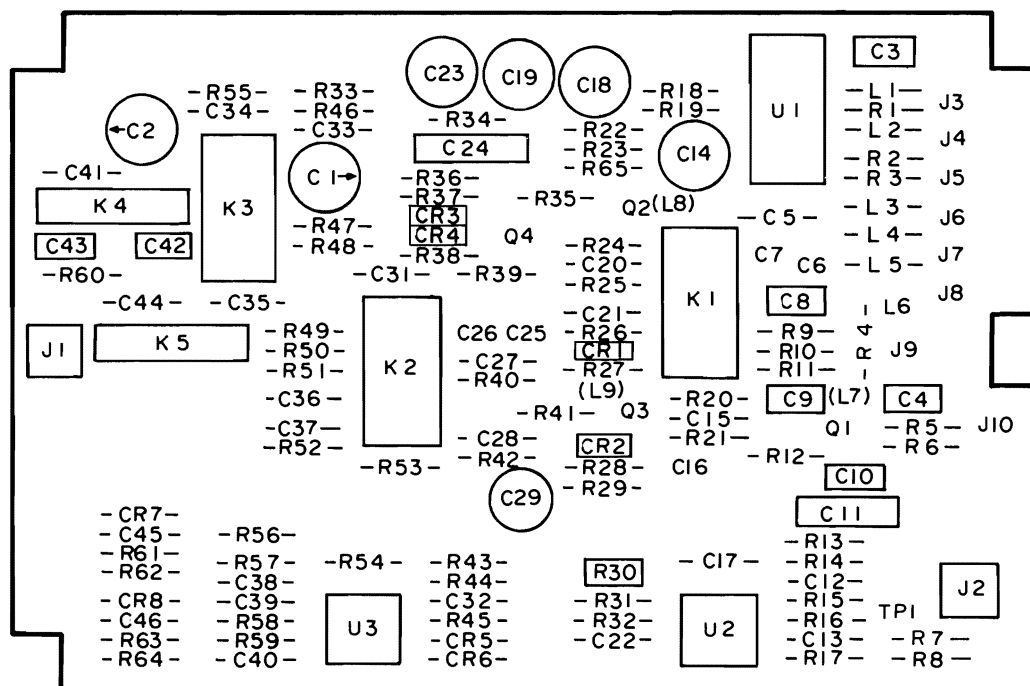

A21A1 Test Channel Amplifier Component Locations

A21A1 TEST CHANNEL AMPLIFIER

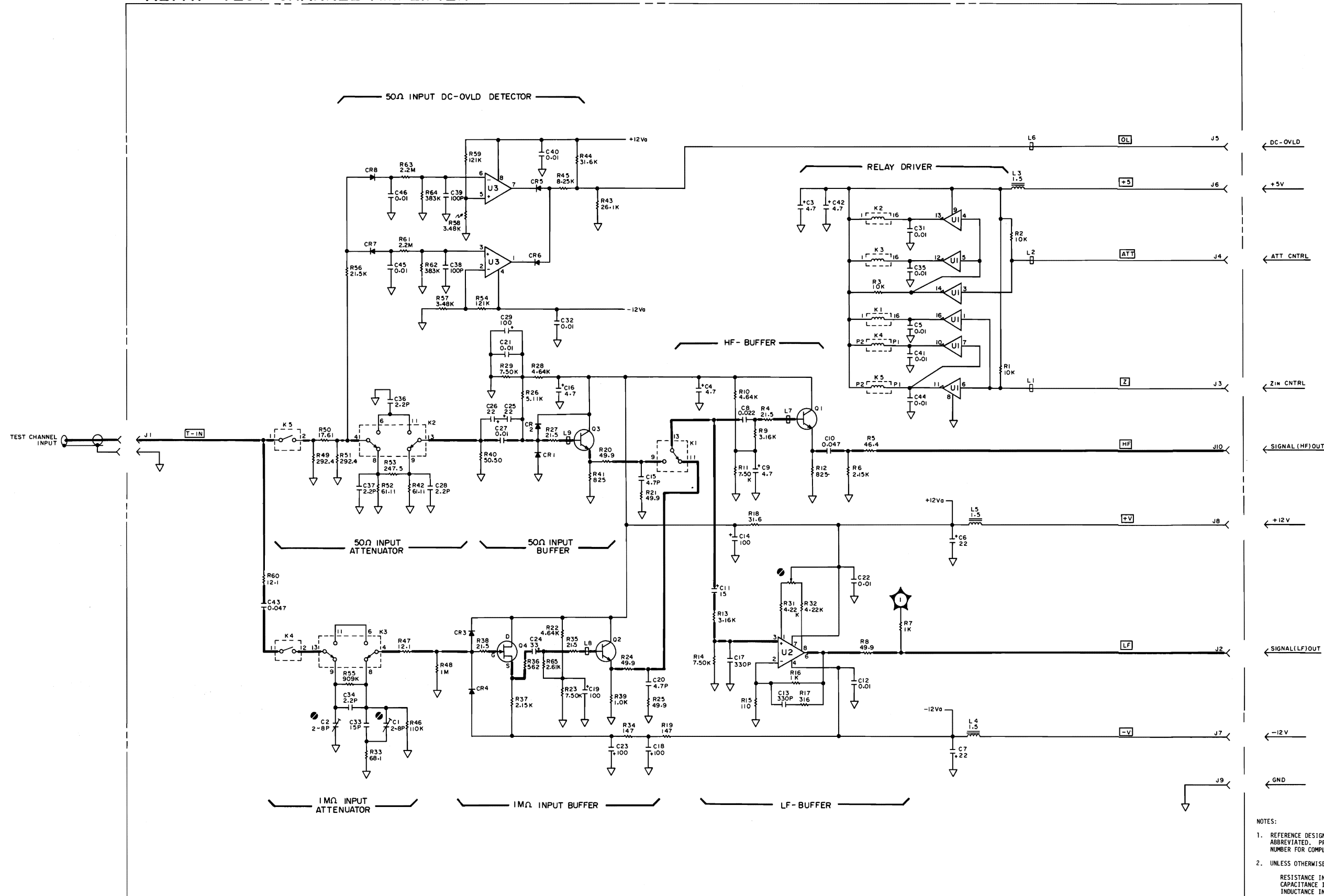

NOTES:
 1. REFERENCE DESIGNATORS WITHIN THIS ASSEMBLY ARE ABBREVIATED. PREFIX ABBREVIATION WITH ASSEMBLY NUMBER FOR COMPLETE REFERENCE DESIGNATOR.
 2. UNLESS OTHERWISE INDICATED:
 RESISTANCE IN OHMS (Ω)
 CAPACITANCE IN MICROFARADS (μF)
 INDUCTANCE IN MICROHENRIES (μH)

A21A1 Test Channel Amplifier Schematic Diagram

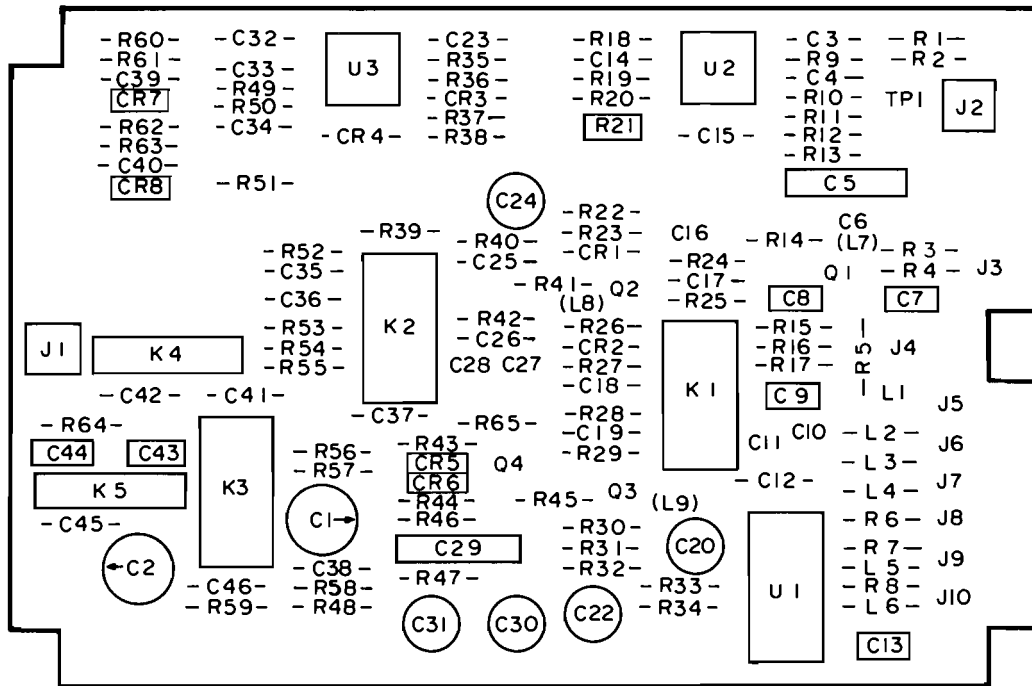

A21A2 Reference Channel Amplifier Component Locations

A21A2 REFERENCE CHANNEL AMPLIFIER

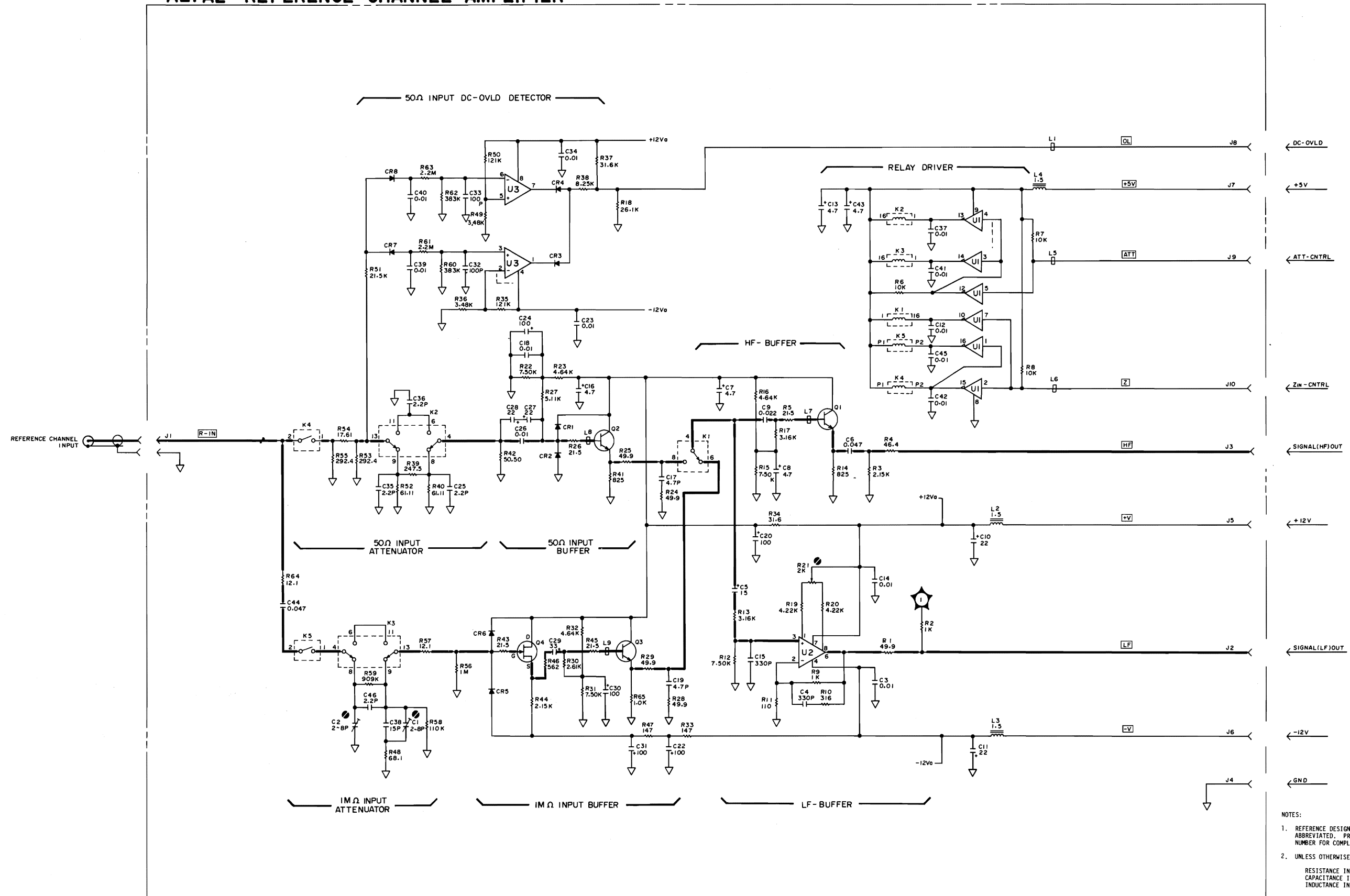

NOTES:
 1. REFERENCE DESIGNATORS WITHIN THIS ASSEMBLY ARE ABBREVIATED. PREFIX ABBREVIATION WITH ASSEMBLY NUMBER FOR COMPLETE REFERENCE DESIGNATOR.
 2. UNLESS OTHERWISE INDICATED:
 RESISTANCE IN OHMS (Ω)
 CAPACITANCE IN MICROFARADS (μF)
 INDUCTANCE IN MICROHENRIES (μH)

A21A2 Reference Channel Amplifier Schematic Diagram

A31A1 TEST CHANNEL AMPLIFIER

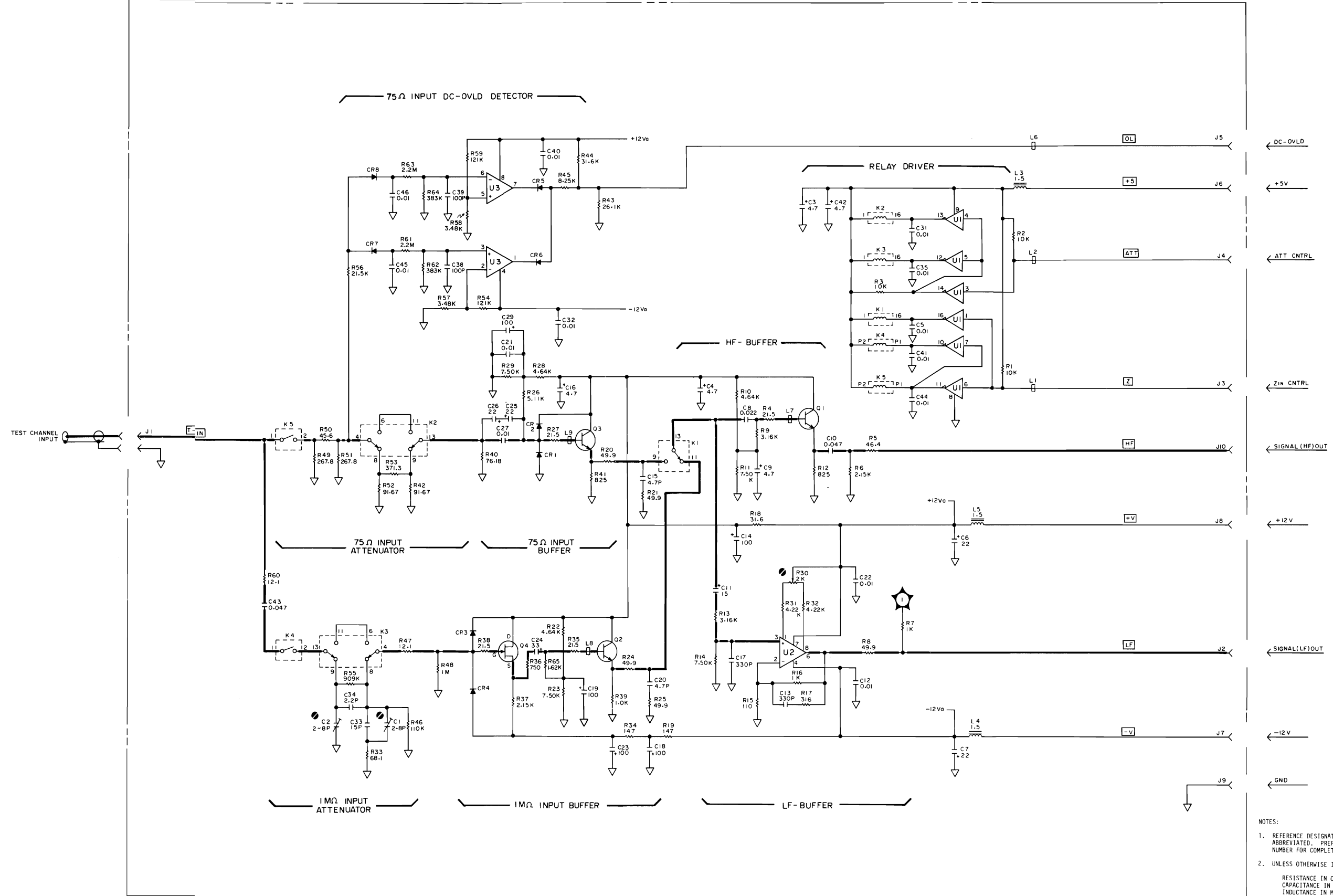

- NOTES:
1. REFERENCE DESIGNATORS WITHIN THIS ASSEMBLY ARE ABBREVIATED. PREFIX ABBREVIATION WITH ASSEMBLY NUMBER FOR COMPLETE REFERENCE DESIGNATOR.
 2. UNLESS OTHERWISE INDICATED:
RESISTANCE IN OHMS (Ω)
CAPACITANCE IN MICROFARADS (μF)
INDUCTANCE IN MICROHENRIES (μH)

A31A1 Test Channel Amplifier Schematic Diagram

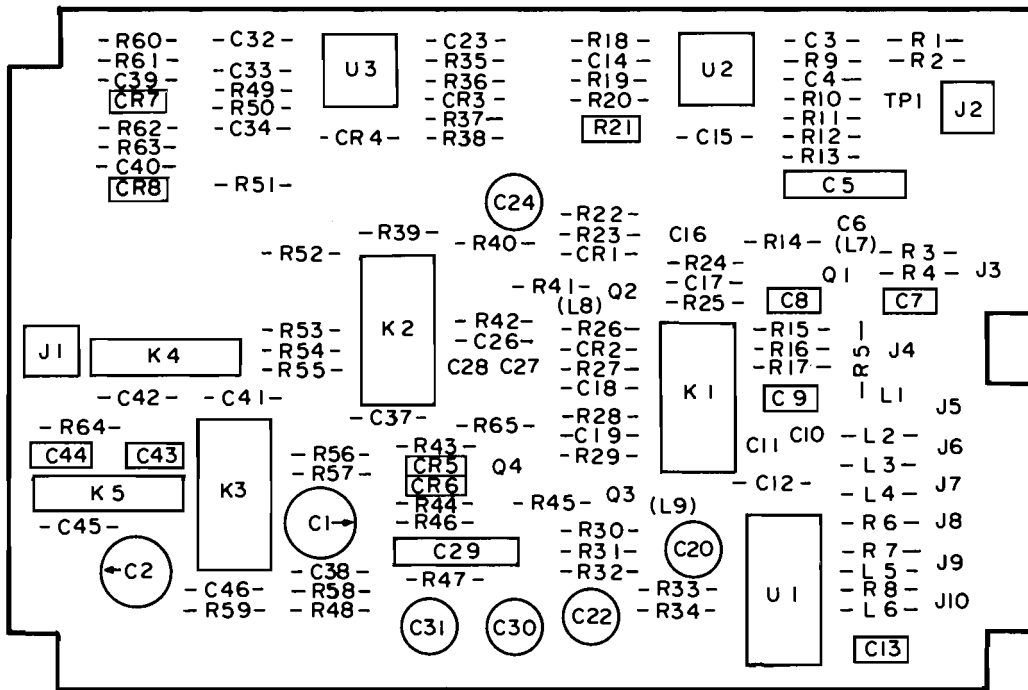

A31A2 Reference Channel Amplifier Component Locations

A31A2 REFERENCE CHANNEL AMPLIFIER

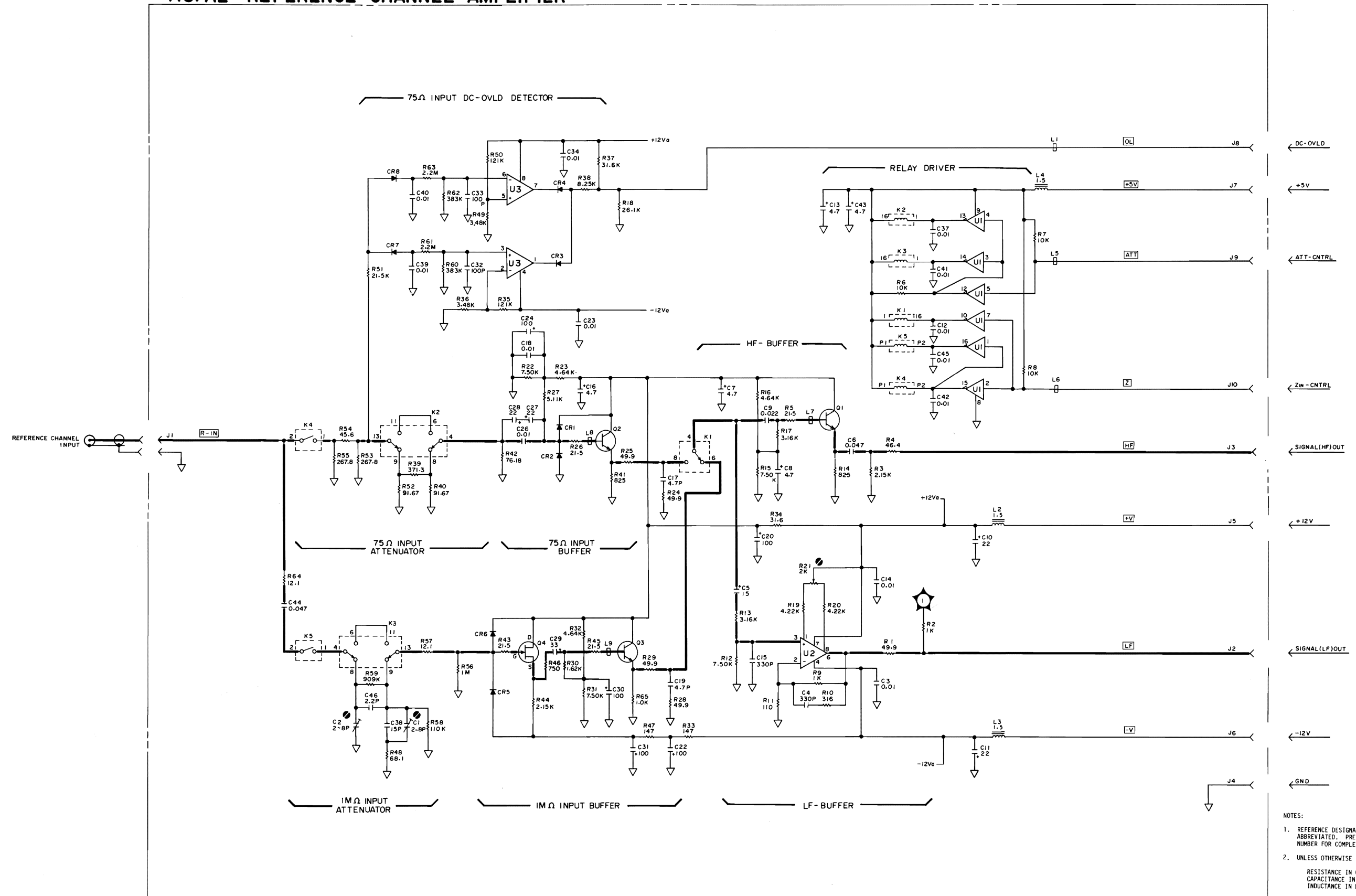

NOTES:
 1. REFERENCE DESIGNATORS WITHIN THIS ASSEMBLY ARE ABBREVIATED. PREFIX ABBREVIATION WITH ASSEMBLY NUMBER FOR COMPLETE REFERENCE DESIGNATOR.
 2. UNLESS OTHERWISE INDICATED:
 RESISTANCE IN OHMS (Ω)
 CAPACITANCE IN MICROFARADS (μF)
 INDUCTANCE IN MICROHENRIES (μH)

A31A2 Reference Channel Amplifier Schematic Diagram

A22 Modulator/Frequency Converter Service Sheet

Figure A22-1 is the block diagram of the A22 Modulator/Frequency Converter board. A22 contains phase detectors, integrators, and a vector generator as part of the bridge circuit, an OSC Level controller, frequency mixers, and digital signal buffers. All digital signals between the control unit and measurement unit are routed through this board.

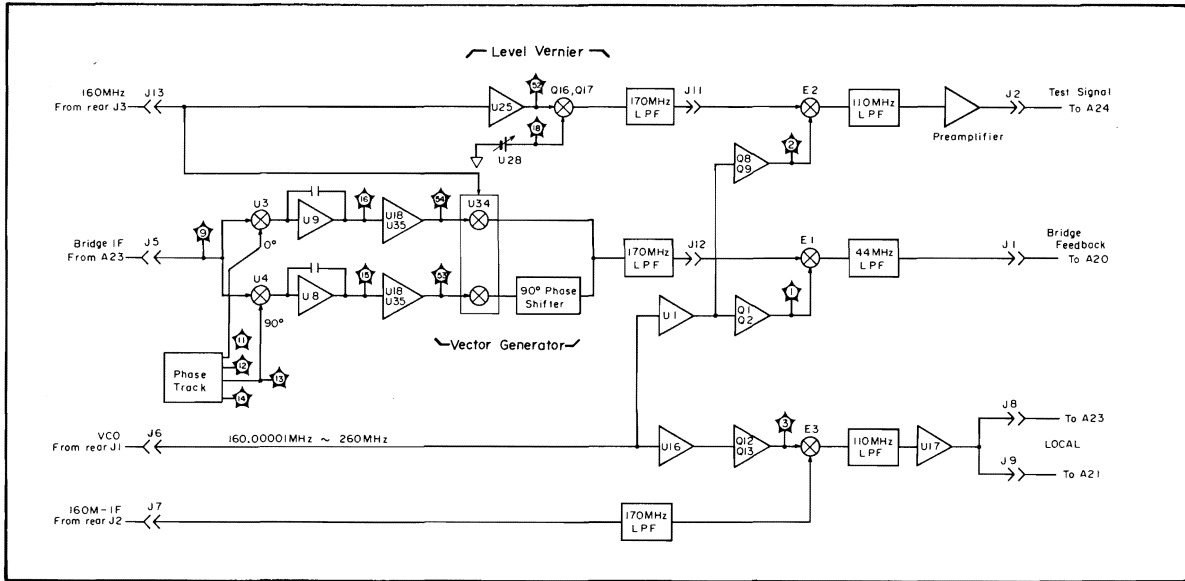

Figure A22-1. A22 Board Block Diagram

The circuit shown in the upper half of the schematic (1 of 3) is the variable OSC LEVEL control block. A simplified block diagram of the level controller is shown in Figure A22-2. D-A converter U28 outputs a dc current proportional to the oscillator's output level. U27 converts dc current into dc voltage. U26 is an inverter and Q18 is a current booster. Switching transistors Q16 and Q17 are driven by the 160MHz signal to turn on alternately. The peak voltage of the 160MHz output signal at Q16's collector is proportional to the D-A converter's output.

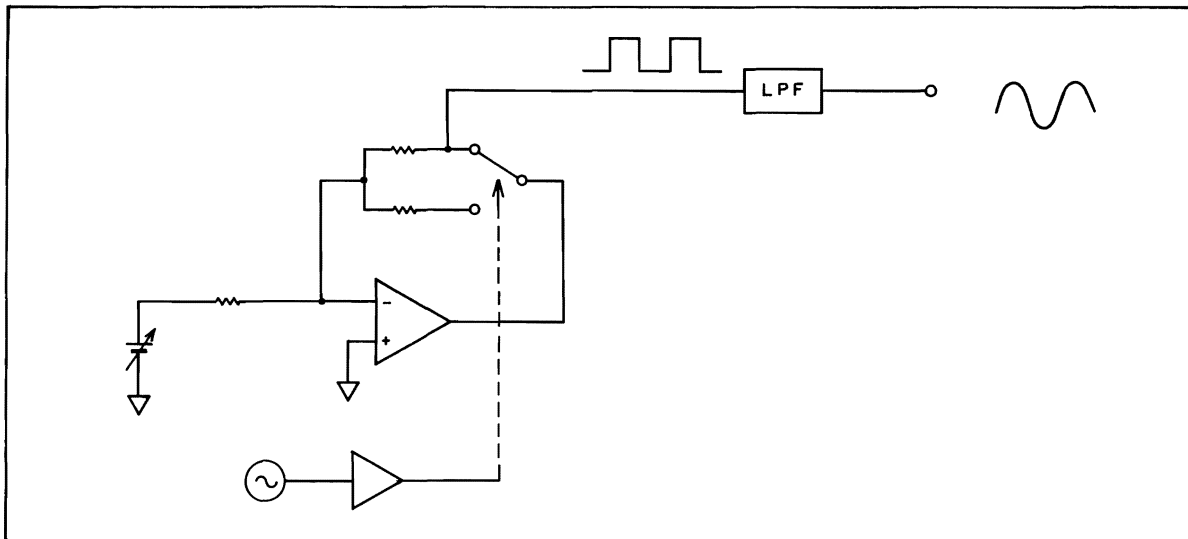

Figure A22-2. OSC Level Controller

The circuit shown on the lower half of the schematic diagram (1 of 3) is the phase detector, integrator and vector generator block. U3 and U4 are phase detectors for the IF signal which is proportional to the bridge's unbalance current from the A23 board. The phase difference between the detection phases is 90° , and their absolute phases values are shifted, using the phase-track data stored in the EEPROM to compensate for the phase shift caused by the auto balance bridge loop integrators, U8 and U9, used in the phase detectors. To obtain the optimum characteristics the Time Constant of the integrators and the loop-gain of the auto balance bridge are switched by Q14 and Q15, respectively. U18 and U35 are dc amplifiers for the output of the integrators. The gain of U18 is selected by the analog switch U19. Refer to Table A22-1. Two dc voltages, proportional to the vector components of unbalance current, modulate the 160MHz signal in U34, a vector generator HIC. L40, U42, C125 and C138 are used to shift phase of the signal by 90° . The 170MHz low pass filter rejects the higher spurious frequencies from the summed signal.

Three frequency mixers on A22 are shown on the schematic diagram (2 of 3). Mixer E1 mixes the 160MHz vector generator's output with the VCO's output (160.00001MHz to 260MHz) to generate the L_{CUR} output signal. E2 mixes the 160MHz OSC level controller's output with the VCO's output for test and signal output. The test signal is goes through a preamplifier before going to the A24 board. The output frequency of mixers E1 and E2 equals the test signal frequency. Mixer E3 mixes the 160MHz-IF signal with the VCO signal to generate the $f_{TEST+IF}$ signal as the local signal for the mixers on the A21 and A23 boards.

The circuit shown on schematic diagram (3 of 3) is the buffer and interface between the measurement and control unit. U23 and U32 are serial-to-parallel data converters.

Table A22-1. Integration Capacitance and U18's Gain versus Test Frequency

Test Frequency	Capacitor	Gain
100Hz to 300Hz	3.6 μ F	1.7
300Hz to 1kHz	3.6 μ F	3.9
1kHz to 3kHz	0.33 μ F	1.7
3kHz to 10kHz	0.33 μ F	3.9
10kHz to 40MHz	0.33 μ F	6.6

A22U37 and LEDs (DS5 through DS12) are designed to serve double duty as a test circuit for some of the serial analog-control data. Normally shift register (A22U37) is used as a serial-to-parallel converter for the lower byte of the OSC Level control signal. When the serial data test is performed, the lower byte of the OSC Level cannot be controlled, but this will cause an error in the OSC Level of only a few percent, so the 4194A will still function normally.

TEST MODE SETTING

1. Change A22W8 to the Test position. This step isolates the data latch (A22U36) from the A22U37's parallel output data.
2. Change A22W9 to the Test position. This step disconnects A22U37's input line from its normal input line (B-LVL-L).
3. Connect one end of a clip lead to A22TP56. The other lead is connected to the signal to be tested.

Note

Reset A22W8 to its Normal position when you finished the test, or OSC level cannot be controlled properly.

BIAS-L/BIAS-U and B-BIAS-L/B-BIAS-U (A22TP34 and TP26)

BIAS-L	Description
LSB	not assigned
2nd bit	not assigned
3rd bit	0: BIAS OFF, 1: BIAS ON
4th bit	0: Negative Bias Voltage, 1: Positive Bias Voltage
5th bit	10mV bit of the D-A converter
6th bit	20mV bit of the D-A converter
7th bit	40mV bit of the D-A converter
MSB	80mV bit of the D-A converter

BIAS-U	Description
LSB	160mV bit of the D-A converter
2nd bit	320mV bit of the D-A converter
3rd bit	640mV bit of the D-A converter
4th bit	1.28V bit of the D-A converter
5th bit	2.56V bit of the D-A converter
6th bit	5.12V bit of the D-A converter
7th bit	10.24V bit of the D-A converter
MSB	20.48V bit of the D-A converter

IF-SW and B-IF-SW Signal (A22TP29)

IF-SW	Description
LSB	0: 156.25kHz IF, 1: 138.889kHz IF
2nd bit	0: 138.889kHz IF, 1: 156.25kHz IF
3rd bit	A23 3kHz LPF, 0: on, 1: off
4th bit	A23 30kHz LPF, 0: on, 1: off
5th bit	Test freq, 0: < 30kHz, 1: ≥ 30kHz
6th bit	Bridge loop gain selection
7th bit	Bridge loop gain selection
MSB	Bridge loop gain selection

Figure A22-3. Serial Data Check Procedure (1 of 5)

Test Frequency Settings		bit							
from	to	7	6	5	4	3	2	1	0
10Hz	299.999Hz	1	1	0	0	1	0	1	0
300Hz	999.999Hz	1	0	1	0	1	0	1	0
1kHz	2.999999kHz	0	1	0	0	0	1	1	0
3kHz	9.999999kHz	0	0	1	0	0	1	1	0
10kHz	9.999999kHz	0	0	0	0	1	1	1	0
30kHz	49.999999kHz	0	0	0	1	1	1	1	0
50kHz	53.999999kHz	0	0	0	1	1	1	0	1
54kHz	59.999999kHz	0	0	0	1	1	1	1	0
60kHz	64.999999kHz	0	0	0	1	1	1	0	1
65kHz	74.999999kHz	0	0	0	1	1	1	1	0
75kHz	84.999999kHz	0	0	0	1	1	1	0	1
85kHz	99.999999kHz	0	0	0	1	1	1	1	0
100kHz	109.999999kHz	0	0	0	1	1	1	0	1
110kHz	147.999999kHz	0	0	0	1	1	1	1	0
148kHz	164.999999kHz	0	0	0	1	1	1	0	1
165kHz	199.999999kHz	0	0	0	1	1	1	1	0
200kHz	219.999999kHz	0	0	0	1	1	1	0	1
220kHz	294.999999kHz	0	0	0	1	1	1	1	0
295kHz	329.999999kHz	0	0	0	1	1	1	0	1
330kHz	439.999999kHz	0	0	0	1	1	1	1	0
440kHz	499.999999kHz	0	0	0	1	1	1	0	1
500kHz	599.999999kHz	0	0	0	1	1	1	1	0
600kHz	649.999999kHz	0	0	0	1	1	1	0	1
650kHz	899.999999kHz	0	0	0	1	1	1	1	0
900kHz	999.999999kHz	0	0	0	1	1	1	0	1
1MHz	100MHz	0	0	0	1	1	1	1	0

Figure A22-3. Serial Data Check Procedure (2 of 5)

FNCTN (A22TP8)

FNCTN	Description
LSB	not assigned
2nd bit	not assigned
3rd bit	0: NORMAL, 1: SELF TEST
4th bit	not assigned
5th bit	not assigned
6th bit	0: NORMAL, 1: LAMP TEST
7th bit	not assigned
MSB	0: GAIN-PHASE function, 1: IMPEDANCE function

IO-ATT and B-IO-ATT (A22TP39)

IO-ATT	Description
LSB	REFERENCE CHANNEL ATTENUATION 0: 0dB, 1: 20dB
2nd bit	REFERENCE CHANNEL IMPEDANCE 0: 1M Ω , 1: 50 Ω
3rd bit	not assigned
4th bit	TEST CHANNEL ATTENUATION 0: 0dB, 1: 20dB
5th bit	TEST CHANNEL IMPEDANCE 0: 1M Ω , 1: 50 Ω
6th bit	not assigned
7th bit	not assigned
MSB	Gain-Phase OUTPUT 0: DUAL, 1: SINGLE

LVL-L/LVL-U and B-LVL-L/B-LVL-U (A22TP33 and A22TP26)

8-bits of LVL-U and the upper 4-bits of LVL-L are used to control the OSC Level. However, because the level control data are compensated using the calibration data stored in EEPROM, the bit pattern of the data will not have a direct relation to the OSC Level setting.

PH-TRACK and B-PH-TRACK (A22TP32)

Phase track data (0 through 15) can be manually set using SELF TEST #52

LSB through the 4th bit of PH-TRACK represents each bit of phase track data. The 5th bit through the MSB of PH-TRACK is not assigned

Figure A22-3. Serial Data Check Procedure (3 of 5)

LVL-ATT and B-LVL-ATT (A22TP42)

LVL-ATT	Description
LSB	A20 3.3dB attenuator 0: off, 1: on
2nd bit	A20 6.7dB attenuator 0: off, 1: on
3rd bit	A20 13.3dB attenuator 0: off, 1: on
4th bit	A24 attenuator control
5th bit	A24 attenuator control
6th bit	A24 attenuator control
7th bit	A24 attenuator control
MSB	A24 attenuator control

For Option #350

OSC LEVEL		bit							
from	to	7	6	5	4	3	2	1	0
9.7dBm	15.0dBm	0	0	0	0	0	1	1	0
9.0dBm	9.6dBm	0	0	0	0	0	1	0	1
6.3dBm	8.9dBm	0	0	1	0	0	1	0	1
5.0dBm	6.2dBm	0	0	1	0	0	1	0	0
3.0dBm	4.9dBm	0	1	0	0	0	1	0	0
-0.3dBm	2.9dBm	0	1	0	0	0	0	1	1
-1.0dBm	-0.4dBm	0	1	0	0	0	0	1	0
-3.7dBm	-1.1dBm	0	1	1	0	0	0	1	0
-5.0dBm	-3.8dBm	0	1	1	0	0	0	0	1
-7.0dBm	-5.1dBm	1	0	0	0	0	0	0	1
-11.0dBm	-7.1dBm	1	0	0	0	0	0	0	0
-15.0dBm	-11.1dBm	1	0	1	0	0	0	0	0
-21.0dBm	-15.1dBm	1	1	0	0	0	0	0	0
-25.0dBm	-21.1dBm	1	1	1	0	0	0	0	0
-31.0dBm	-25.1dBm	1	1	0	0	1	0	0	0
-35.0dBm	-31.1dBm	1	1	1	0	1	1	1	1
-41.0dBm	-35.1dBm	1	1	0	1	0	1	1	1
-45.0dBm	-41.1dBm	1	1	1	1	0	1	1	1
-51.0dBm	-45.1dBm	1	1	0	1	1	1	1	1
-65.0dBm	-51.1dBm	1	1	1	1	1	1	1	1

Figure A22-3. Serial Data Check Procedure (4 of 5)

For Option #375

OSC LEVEL Setting		bit							
from	to	7	6	5	4	3	2	1	0
9.0dBm	15.0dBm	0	0	0	0	0	1	1	0
7.9dBm	8.9dBm	0	0	1	0	0	1	1	0
5.0dBm	7.8dBm	0	0	1	0	0	1	0	1
4.6dBm	4.9dBm	0	1	0	0	0	1	0	1
1.2dBm	4.5dBm	0	1	0	0	0	1	0	0
-1.0dBm	1.2dBm	0	1	0	0	0	0	1	1
-2.1dBm	-1.1dBm	0	1	1	0	0	0	1	1
-5.0dBm	-2.1dBm	0	1	1	0	0	0	1	0
-5.4dBm	-5.1dBm	1	0	0	0	0	0	1	0
-8.8dBm	-5.5dBm	1	0	0	0	0	0	0	1
-11.0dBm	-8.9dBm	1	0	0	0	0	0	0	0
-15.0dBm	-11.1dBm	1	0	1	0	0	0	0	0
-21.0dBm	-15.1dBm	1	1	0	0	0	0	0	0
-25.0dBm	-21.1dBm	1	1	1	0	0	0	0	0
-31.0dBm	-25.1dBm	1	1	0	0	1	1	1	1
-35.0dBm	-31.1dBm	1	1	1	0	1	1	1	1
-41.0dBm	-35.1dBm	1	1	0	1	0	1	1	1
-45.0dBm	-41.1dBm	1	1	1	1	0	1	1	1
-51.0dBm	-45.1dBm	1	1	0	1	1	1	1	1
-65.0dBm	-51.1dBm	1	1	1	1	1	1	1	1

ZT-RNG and B-ZT-RNG (A22TP41)

The impedance measurement range can be manually set using the following procedure.

1. Set A8SW1-7 to **ON**.
2. Enter one of the RZ1 through RZ4 commands from the front panel.

LSB of ZT-RNG 0: 50Ω range, 1: one of other ranges
 2nd bit of ZT-RNG 0: 400Ω range, 1: one of other ranges
 3rd bit of ZT-RNG 0: 3.2kΩ range, 1: one of other ranges
 4th bit of ZT-RNG 0: 25kΩ range, 1: one of other ranges
 5th bit through MSB of ZT-RNG are not assigned

Figure A22-3. Serial Data Check Procedure (5 of 5)

Table A22-2. A22 Troubleshooting Aids (1 of 2)

Reference Designator	Description	Use
DS1 ~ DS4	Integrator limiter indicator	Change W4 and W5 and rotate R124 and R127 fully CW and CCW several times to check the limiter.
DS5 ~ DS12	U37 output bit pattern indicator	Refer to Figure A22-3.
W1, W2	U8/U9 feedback selection	N: Connects to integration capacitor. T: Connects to feedback resistor. Used when adjusting U8 or U9's dc offset.
W4, W5	U8/U9 dc offset I range	N: Normal offset I range. T: Excessive offset I can be forced to check the integrator's limiter circuit and the vector generator.
W6	Reset line on A22's digital ICs	N: Connects to power on rest circuit. T: Resets ICs.
W7	Level vernier control dc V	N: Connects to DAC output. T: Connects to 5V. Signal level at J11 should be more than -20dBm. Open: Signal level at J11 should be less than -40dBm.
W8	OSC level lower bit control wnable/disable	N: Lower data bits are latched at the positive going transition of the EOD signal. T: Previous lower bit data is kept. This is related to W9 usage.
W9	U37 serial data latch control	N: B-LVL-L signal is connected. T: Measurement control signal test. Refer to Figure A22-3.

Table A22-2. A22 Troubleshooting Aids (2 of 2)

Reference Designator	Description	Use
TP9	Bridge IF input	Disconnect the cable from J5. Connect TP9 any one of the following TPs: 11 ~ 14. The output phase of L _{cur} referenced to the H _{cur} terminal should be shifted 90°.
TP56	Serial data test input	Disconnect the jumper from W9. Connect TP56 to any one of the following TPs: 25, 26, 28, 29, 32 ~ 34, or 40 ~ 42. Check the bit pattern indicated by DS5 ~ DS12.

ArtekManuals © 2018
Table A22-3. A22 Troubleshooting Data (1 of 2)

Step	HP 4194A Settings	Measurement Setup	Main Parameters	Waveform
1	CENTER:100Hz SPAN:0Hz OSC:1V TRIGGER: EXT/MAN Connect a BNC-T to the Hcur terminal and connect LPOT to the BNC-T.	Oscilloscope 2ms/DIV CH-A to TP9 dc coupled 5V/DIV CH-B to Hcur via the BNC-T. dc coupled 2V/DIV TRIGGER:CH-B	CH-A waveform	
2	CENTER:1MHz SPAN:0Hz OSC:1V TRIGGER: EXT/MAN Connect Hcur to LPOT with a BNC cable.	Oscilloscope 2µs/DIV CH-A to TP9 dc coupled 5V/DIV TRIGGER.CH-A	Amplitude Waveform	
3	CENTER:1MHz SPAN:0Hz OSC:1V TRIGGER.INT Connect 16047D to UNKNOWN	Oscilloscope 2ms/DIV CH-A to TP9 dc coupled 50mV/DIV TRIGGER:CH-A	White noise Spike noise	
4	CENTER:1MHz SPAN:0Hz	Oscilloscope 1µs/DIV CH-A to TP11 dc coupled 2V/Div CH-B to TP12 dc coupled 2V/DIV TRIGGER.CH-A		
5	Initial settings	Oscilloscope 2µs/DIV CH-A to TP20 dc coupled 2V/Div CH-B to TP19 dc coupled 2V/DIV TRIGGER:CH-B		

Table A22-3. A22 Troubleshooting Data (2 of 2)

Step	HP 4194A Settings	Measurement Setup	Main Parameters	Waveform
6	FUNCTION: GAIN-PHASE OSC:+15dBm	Spec. Analyzer INPUT #2 to J11 START:1MHz STOP:1000MHz ResBW:30kHz RefLevel:-10dBm	160MHz amplitude and harmonics. Spurious frequencies.	
7	FUNCTION: GAIN-PHASE CENTER: 90MHz SPAN:0Hz	Spec. Analyzer INPUT #2 to J8 START:1MHz STOP:500MHz ResBW:30kHz RefLevel:-10dBm	90.15625MHz amplitude and harmonics Spurious: 250MHz, 159.84375MHz 69.6875MHz	
8	FUNCTION: GAIN-PHASE CENTER: 90MHz SPAN:0Hz OSC:+15dBm	Spec. Analyzer INPUT #2 to J2 START:1MHz STOP:500MHz ResBW:30kHz RefLevel:-10dBm	90MHz amplitude and harmonics Spurious: 250, 160, 70, 20MHz	
9	FUNCTION: IMPEDANCE CENTER: 40MHz SPAN:0Hz TRIGGER: EXT/MAN Connect Hcur to LpOT with a BNC cable.	Spec. Analyzer INPUT #2 to J12 START:1MHz STOP:1000MHz ResBW:100kHz RefLevel:0dBm	160MHz amplitude and harmonics Spurious frequencies	
10	Same as 9	Spec. Analyzer INPUT #2 to J1 START:1MHz STOP:250MHz ResBW:30kHz RefLevel:-10dBm	40MHz amplitude and harmonics Spurious.	

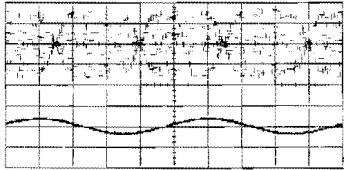
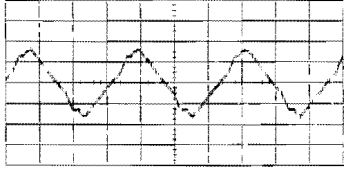
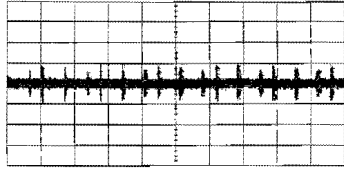
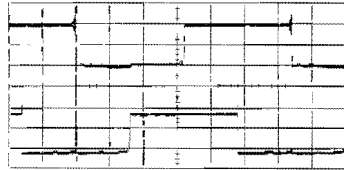
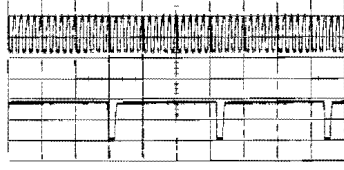
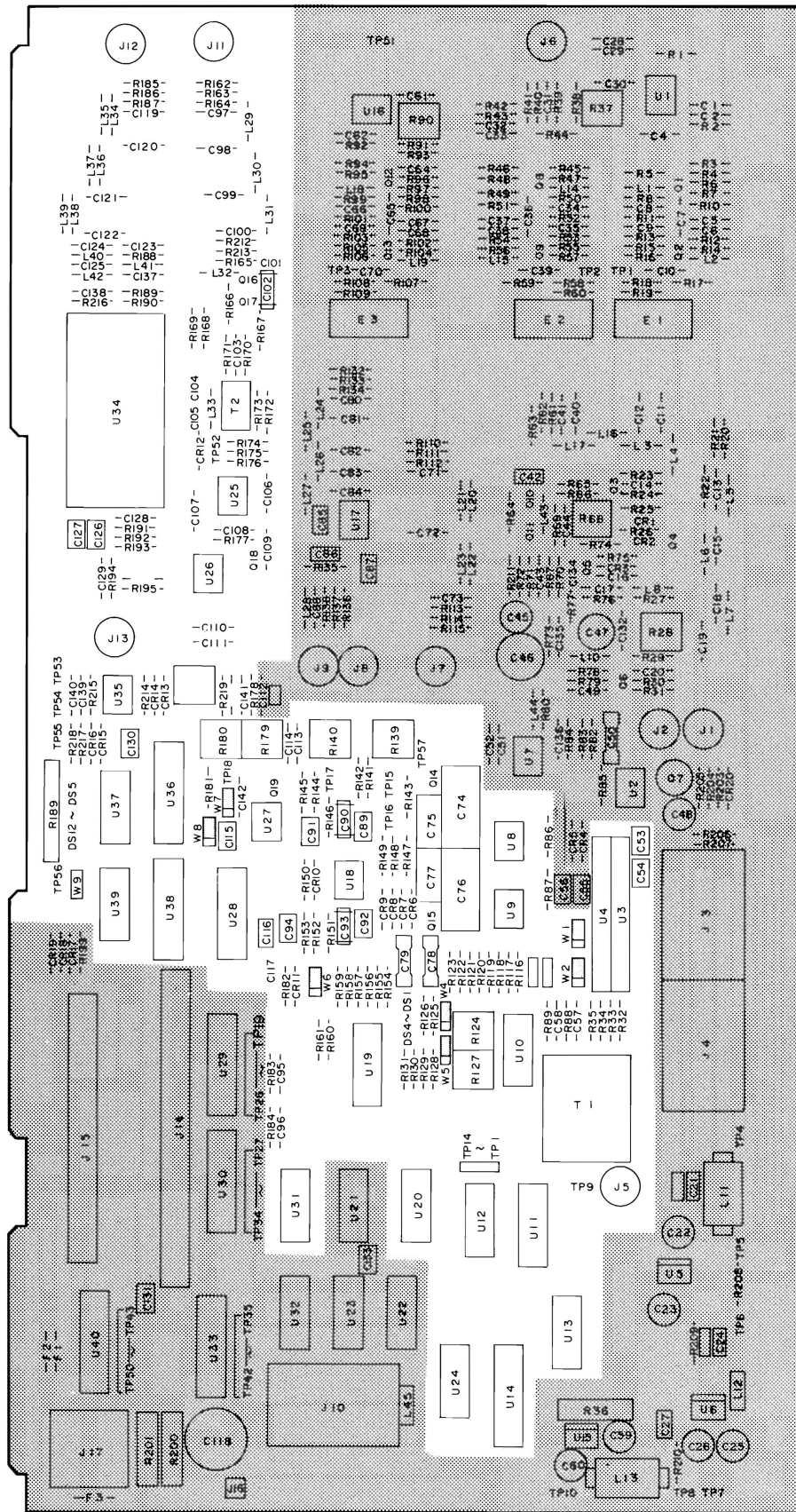

A22 Modulator/Frequency Converter Component Locations (1 of 3)

A22 MODULATOR / FREQUENCY CONVERTER 1 of 3

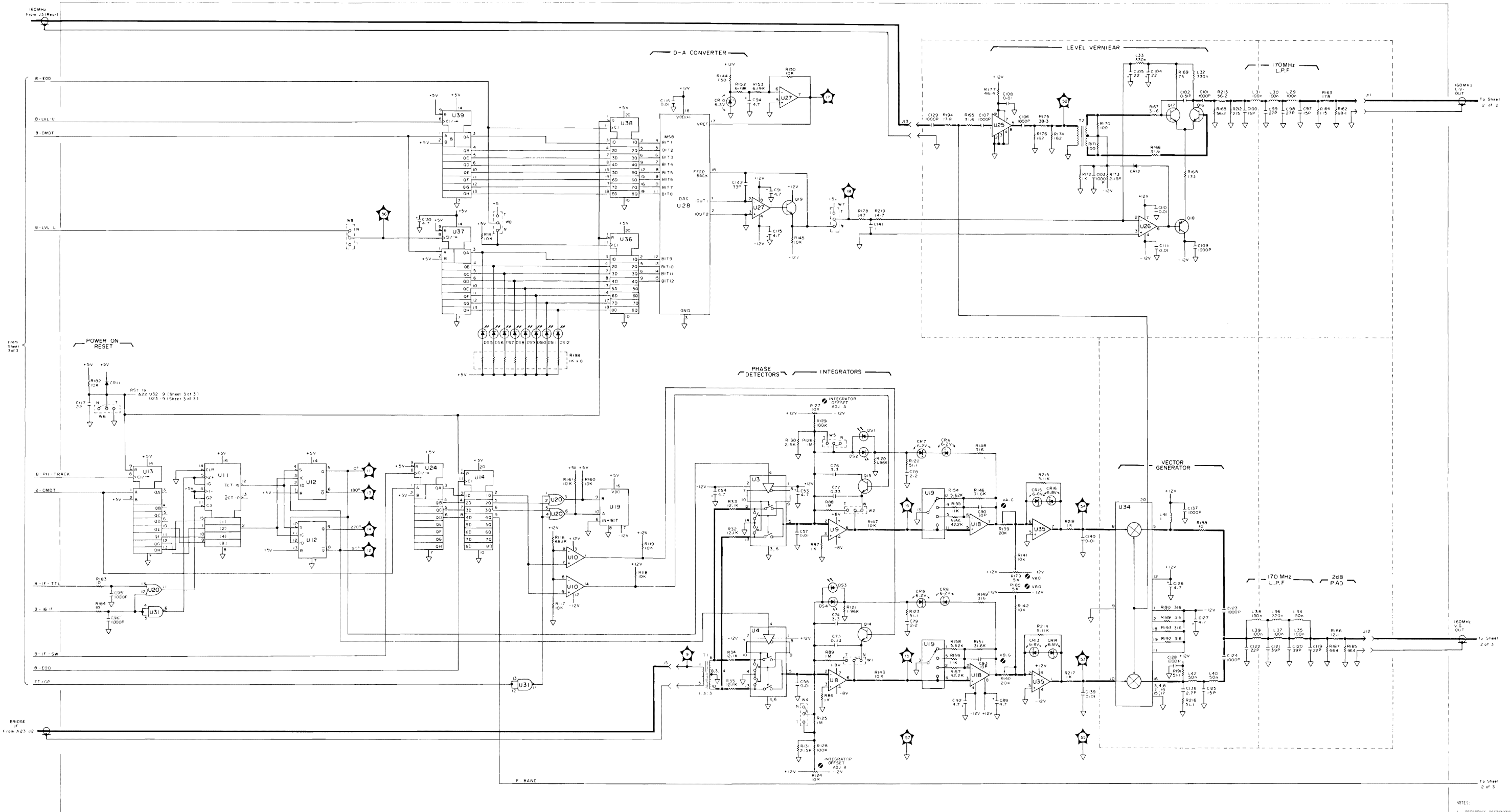

NOTES:
 1. REFERENCE DESIGNATORS WITH THIS ASSEMBLY ARE ABBRUVED TO PREFIX ABBREVIATION WITH ASSEMBLY NUMBER FOR COMPLETE REFERENCE OF QUANTITY.
 2. UNLESS OTHERWISE INDICATED:
 RESISTANCE IN OHMS (Ω)
 CAPACITANCE IN MICROFARADS (μF)
 INDUCTANCE IN MICROHENRIES (μH)

A22 Modulator/Frequency Converter Schematic Diagram (1 of 3)

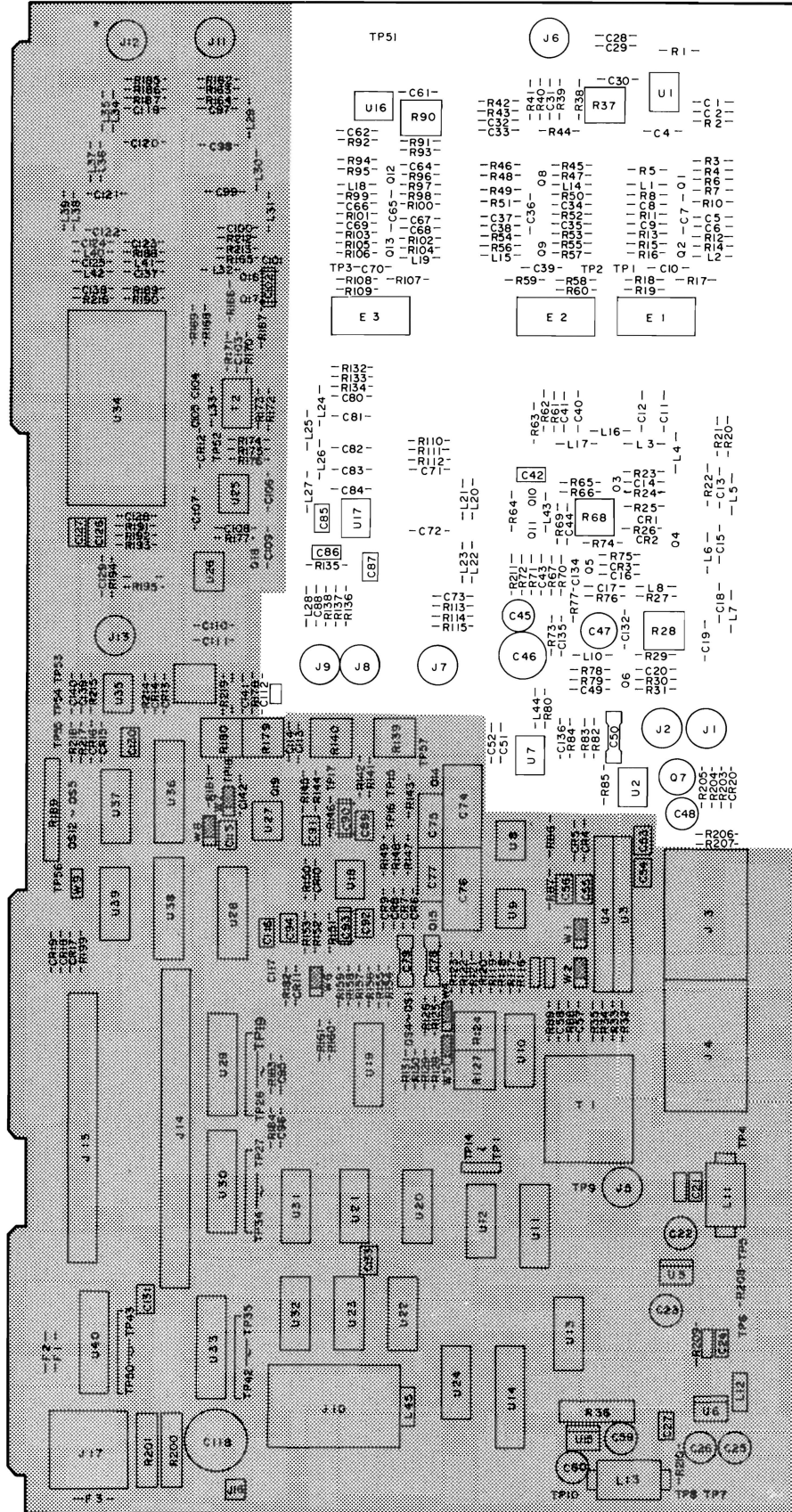

A22 Modulator/Frequency Converter Component Locations (2 of 3)

A22 MODULATOR / FREQUENCY CONVERTER 2 of 3

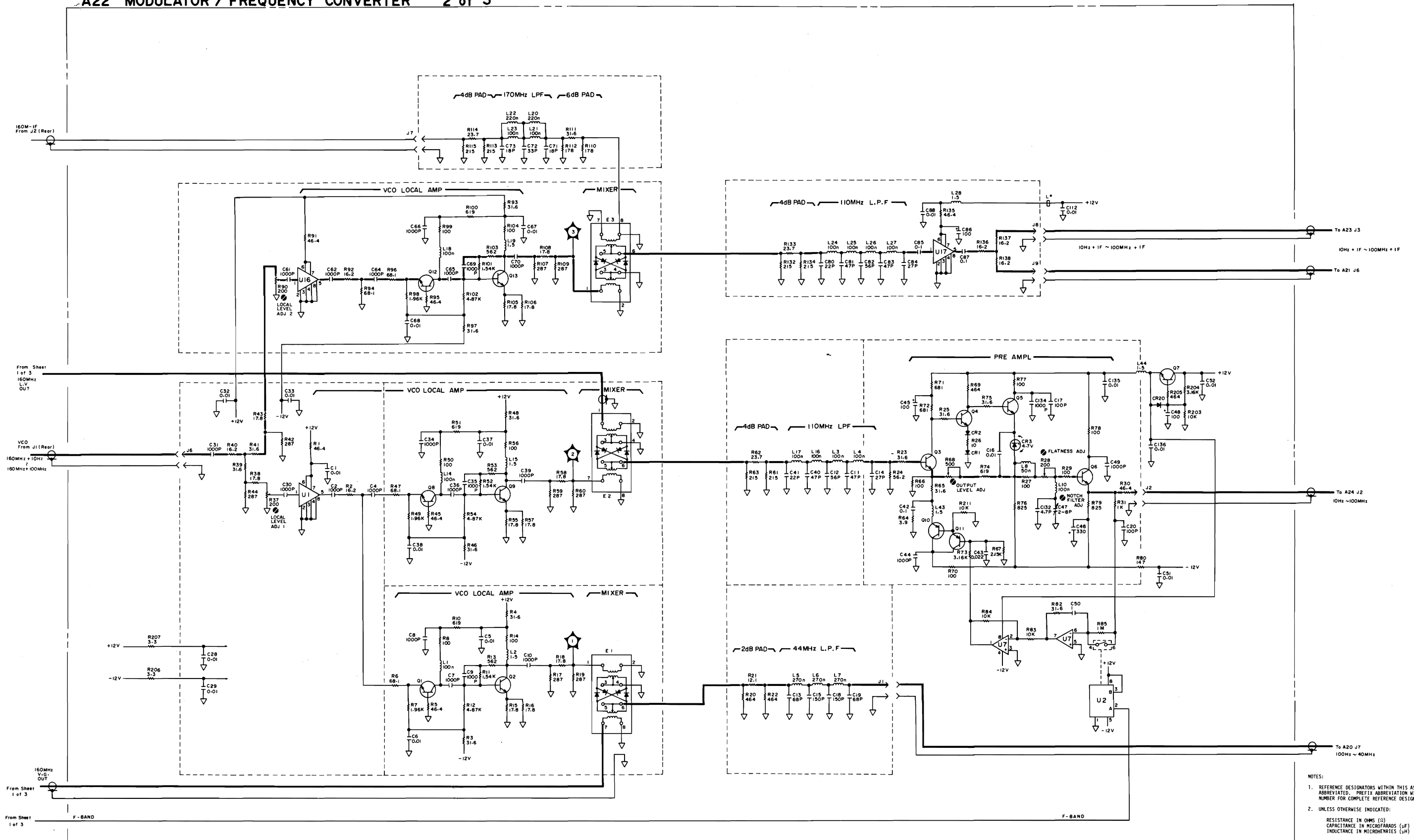

- NOTES:
1. REFERENCE DESIGNATORS WITHIN THIS ASSEMBLY ARE ABBREVIATED. PREFIX ABBREVIATION WITH ASSEMBLY NUMBER FOR COMPLETE DESIGNATOR.
 2. UNLESS OTHERWISE INDICATED:
RESISTANCE IN OHMS (Ω)
CAPACITANCE IN MICROFARADS (μF)
INDUCTANCE IN MICROHENRIES (μH)

A22 Modulator/Frequency Converter Schematic Diagram (2 of 3)

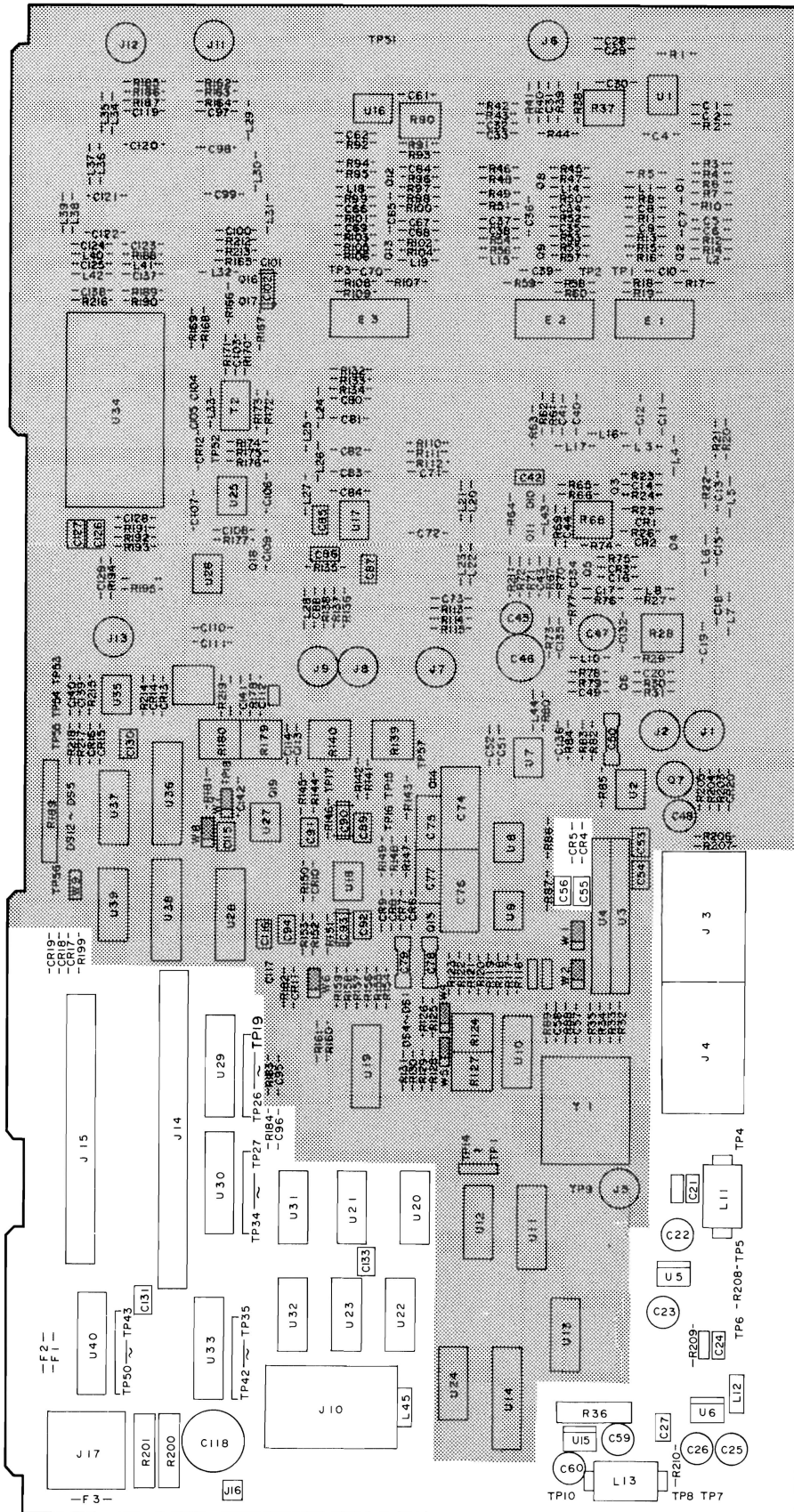

A22 Modulator/Frequency Converter Component Locations (3 of 3)

A23 Null Detector Service Sheet

Figure A23-1 is a block diagram of the A23 Null Detector board. This board converts the bridge unbalance current from the UNKNOWN L_{POT} terminal into an error voltage, and converts the error voltage frequency into the IF frequency. This board also contains the dc bias current sink and the dc bias sink overload, and bridge unbalance detectors.

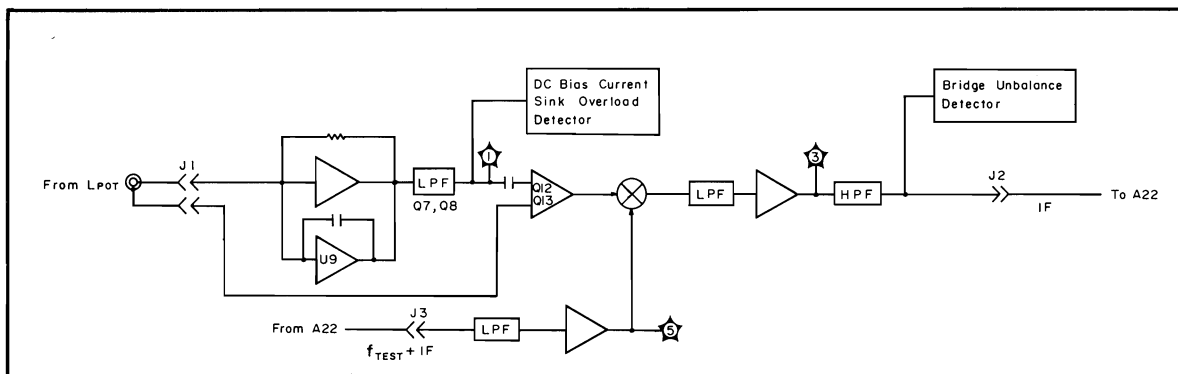

Figure A23-1. A23 Board Block Diagram

An I-V (current to voltage) converter and a dc bias current sink are connected to the UNKNOWN L_{POT} terminal. Q23, Q24, Q16 and Q17 are I-V converters which are used to convert the test signal. U9 and Q25 are used as dc bias sinks. The I-V converters and the dc bias current sink use a common feedback resistor to hold the feedback node at virtual ground. One of the feedback resistors is selected by the same control signal that is used to select the range resistors on the A20 board. The dc output voltage of the I-V converter/dc bias current sink is limited, so the maximum dc bias current depends on the value of the feedback resistors.

Q7, the 3kHz LPF switch is on when the test signal frequency is less than 1kHz, and Q8, the 30kHz LPF switch turns on when the frequency of the test signal is greater than 1kHz but less than 10kHz.

DC bias transient absorbers Q27 and Q10 turn on momentarily when the dc bias voltage is applied or changed. The dc bias sink current overload detector monitors the dc voltage at the output of the dc bias current sink, if the dc voltage exceeds approximately $\pm 1.5V$, the detector generates an overload signal. Q12 and Q13 are differential amplifiers used to interface the I-V converter, which operates from a floating power supply, to other circuits on this board which are grounded to chassis ground.

E1 is a double balanced mixer which down mixes the unbalance voltage of the bridge circuitry to the IF frequency. The local signal, $f_{TEST+IF}$ comes from the A22 board and is amplified before entering the mixer.

The IF signal from the mixer is filtered to reject $f_{TEST+2IF}$, and then amplified before going to the A22 board. The gain of U3 is 30dB when the 50 Ω range resistor is selected, or 42dB when one of the other range resistors are selected. U5 is the bridge-unbalanced detector. An unbalanced condition is detected when a positive peak of the IF signal exceeds approximately 4.5V.

Table A23-1. A23 Troubleshooting Data

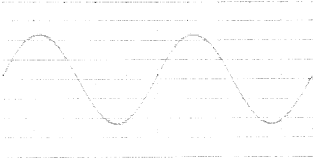
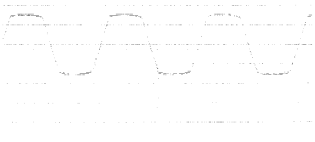
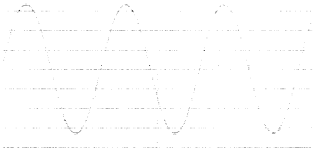
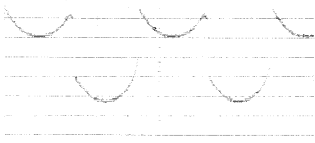
Step	HP 4194A Settings	Measurement Setup	Main Parameters	Waveform
1	<p>SELF TEST 52 SPOT FREQ: 1MHz OSC:1Vrms Z RNG:50Ω (RZ1) Connect H_{cur} and L_{POT} with a BNC cable</p>	<p>Oscilloscope 0.2μs/DIV CH-A to TP1 dc coupled 0.5V/DIV TRIGGER:CH-A</p>	<p>Frequency:1MHz Amplitude: approx. 2.3Vpp</p>	
2	<p>Same as 1</p>	<p>Oscilloscope 2μs/DIV CH-A to TP3 dc coupled 5V/DIV TRIGGER:CH-A</p>	<p>Frequency: 156.25kHz (6.4μs) Amplitude: approx.15Vpp</p>	
3	<p>Same as 1 except OSC: 0.1Vrms</p>	<p>Oscilloscope 2μs/DIV CH-A to TP3 dc coupled 0.5V/DIV TRIGGER:CH-A</p>	<p>Frequency: 156.25kHz (6.4μs) Amplitude: approx.3Vpp</p>	
4	<p>Same as 3</p>	<p>Oscilloscope 0.2μs/DIV CH-A to TP5 dc coupled 0.1V/DIV TRIGGER:CH-A</p>	<p>Frequency: 1.15625MHz (approx.865ns) Amplitude: approx.0.5Vpp</p>	

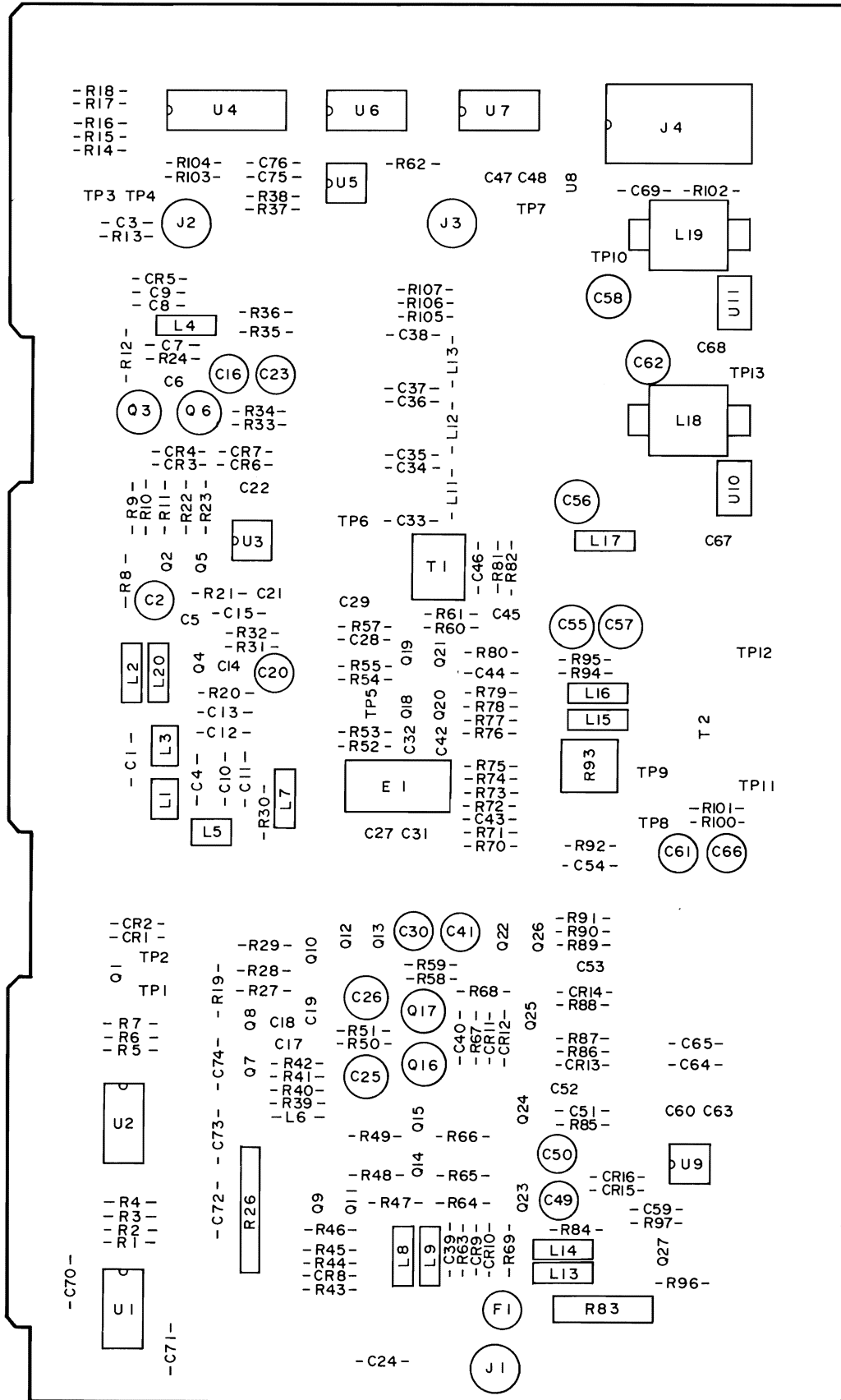

A23 Null Detector Component Locations

A23 NULL DETECTOR

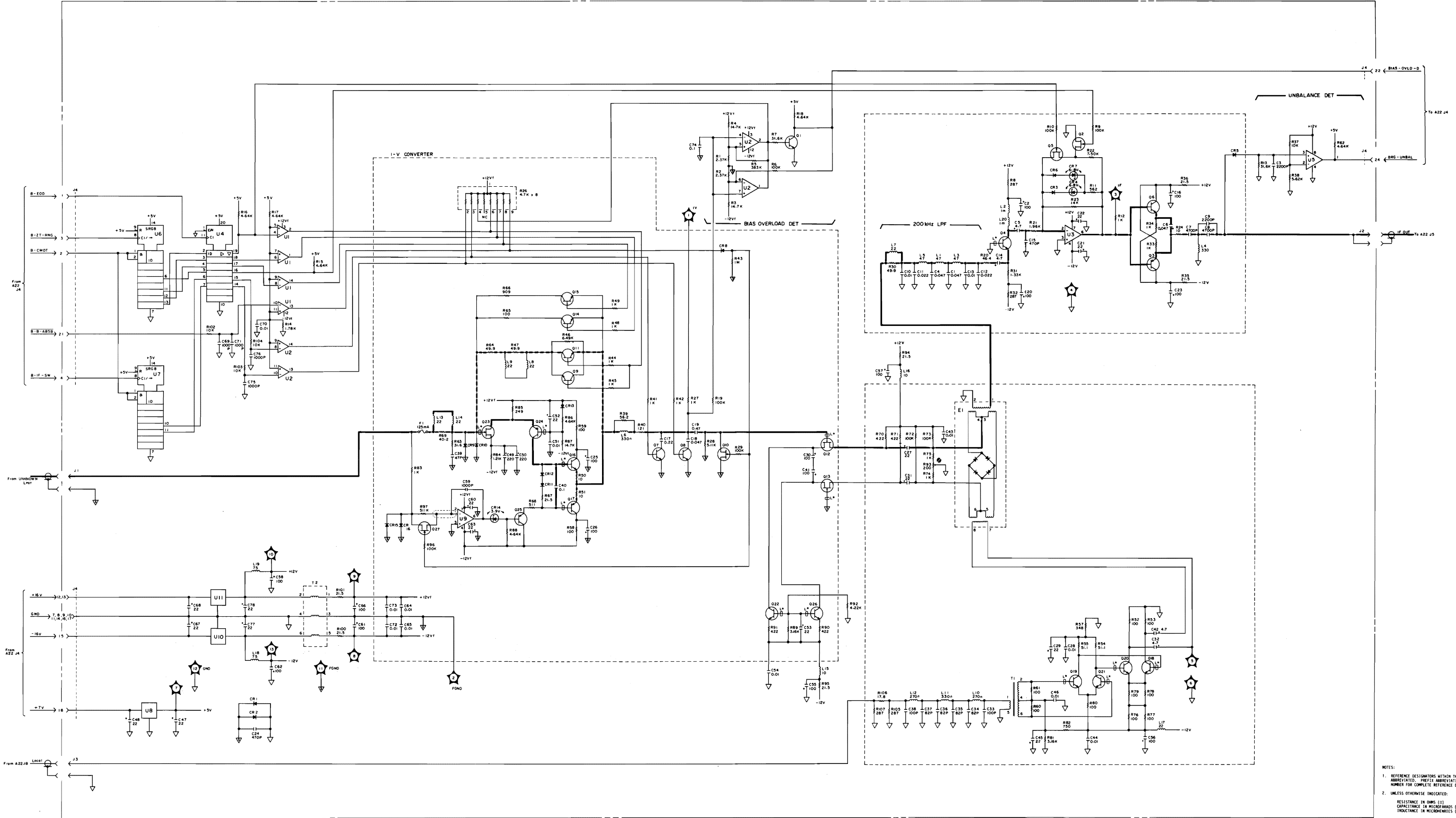

NOTES:
 1. REFERENCE DESIGNATORS WITHIN THIS ASSEMBLY ARE ABBREVIATED. PREFIX ABBREVIATION WITH ASSEMBLY NUMBERS FOR COMPLETE REFERENCE DESIGNATOR.
 2. UNLESS OTHERWISE INDICATED:
 RESISTANCE IN OHMS (Ω)
 CAPACITANCE IN MICROFARADS (μF)
 INDUCTANCE IN MICRORHEMES (μH)

A23 Null Detector Schematic Diagram

A24/A34 Output Amplifier Service Sheet

Figure A24-1 is the block diagram of the A24/A34 Output Amplifier board. This board is designated as A24 for Option 350 or as A34 for Option 375. Included on the A24/A34 board are the attenuators used for coarse control of the oscillator level, a power amplifier, a dc bias voltage source and a dc bias source current overload detector. Subassembly A24A1/A34A1 includes a power splitter for the dual channel output and attenuators. The subassembly is used only for the Gain-Phase function.

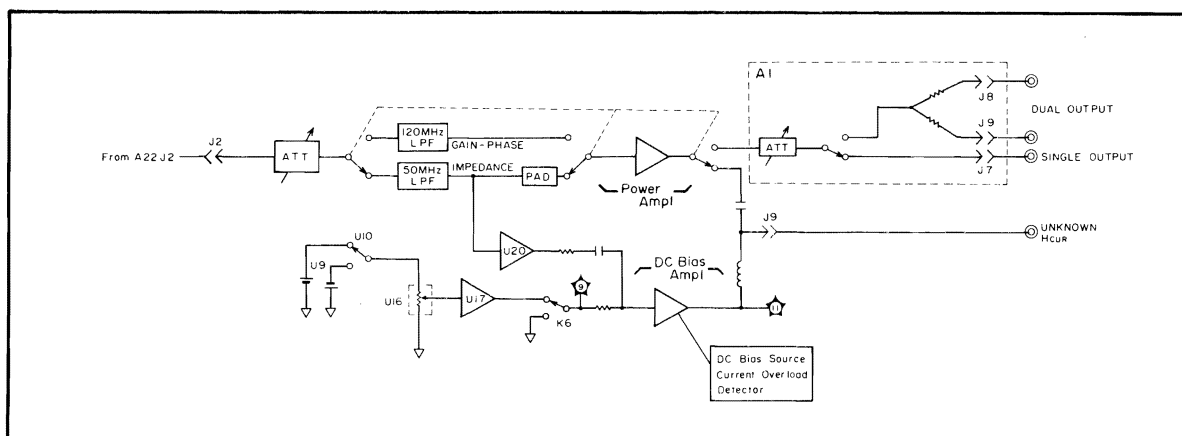

Figure A24-1. A24/A34 Board Block Diagram

The first stage on this board is the attenuators. Table A24-1 gives the OSC LEVEL with different settings of the attenuators. This table also shows the attenuator setting on subassembly A24A1. When in the OSC LEVEL SWEEP mode the attenuators are set as appropriate only for the maximum level of the sweep range, and the OSC LEVEL is controlled only by the level vernier on the A22 board to increase the life of the relay. Relays K1 and K2 select the test signal path depending on the measurement function. When the 4194A is in the gain-phase mode, the power amplifier's bandwidth covers the test signals' the full frequency range. In the impedance measurement mode, the power amplifier amplifies frequencies approximately 3.5kHz above the test signal. The rest of the test signal frequency range is amplified by the dc bias amplifier and summed on the output side of K7.

Table A24-1. Attenuator Setting versus OSC Level

For the Impedance Function

OSC Level			20dB	10dB	6dB	total
9.0dBm	to	Max Level	off	off	off	0dB
5.0dBm	to	8.9dBm	off	off	on	6dB
-1.0dBm	to	4.9dBm	off	on	off	10dB
-5.0dBm	to	-1.1dBm	off	on	on	16dB
-11.0dBm	to	-5.1dBm	on	off	off	20dB
-15.0dBm	to	-11.1dBm	on	off	on	26dB
-21.0dBm	to	-15.1dBm	on	on	off	30dB
Min Level	to	-21.1dBm	on	on	on	36dB

For Option 350, MaxLevel is 13dBm and MinLevel is -27dBm

For Option 375, MaxLevel is 11.2dBm and MinLevel is -28.8dBm

For the Gain-Phase Function

OSC Level			20dB	10dB	6dB	20dB	10dB	total
9.0dBm	to	15.0dBm	off	off	off	off	off	0dB
5.0dBm	to	8.9dBm	off	off	on	off	off	6dB
-1.0dBm	to	4.9dBm	off	off	off	off	on	10dB
-5.0dBm	to	-1.1dBm	off	off	on	off	on	16dB
-11.0dBm	to	-5.1dBm	off	off	off	on	off	20dB
-15.0dBm	to	-11.1dBm	off	off	on	on	off	26dB
-21.0dBm	to	-15.1dBm	off	off	off	on	on	30dB
-25.0dBm	to	-21.1dBm	off	off	on	on	on	36dB
-31.0dBm	to	-25.1dBm	off	on	off	on	on	40dB
-35.0dBm	to	-31.1dBm	off	on	on	on	on	46dB
-41.0dBm	to	-35.1dBm	on	off	off	on	on	50dB
-45.0dBm	to	-41.1dBm	on	off	on	on	on	56dB
-51.0dBm	to	-45.1dBm	on	on	off	on	on	60dB
-65.0dBm	to	-51.1dBm	on	on	on	on	on	66dB

Table A24-2. A24 Troubleshooting Data

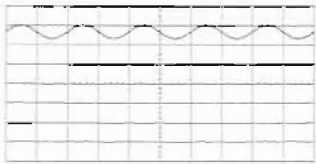
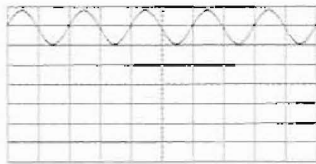
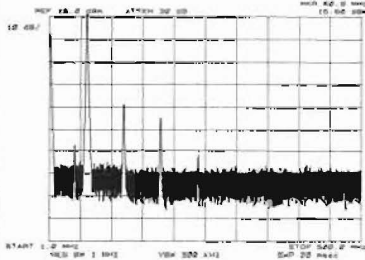
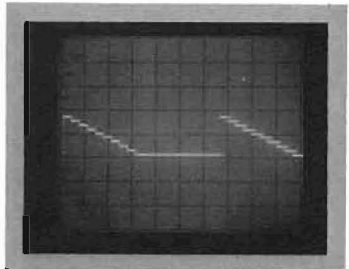
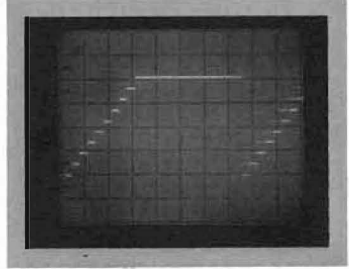
Step	HP 4194A Settings	Measurement Setup	Main Parameters	Waveform
1	CENTER: 100kHz SPAN:0Hz	Oscilloscope 5 μ s/DIV CH-A to TP12 dc coupled 0.1V/DIV TRIGGER:CH-A	dc offset ac amplitude	
2	same as 1	Oscilloscope 5 μ s/DIV CH-A to TP13 dc coupled 0.05V/DIV TRIGGER:CH-A	dc offset ac amplitude	
3	FUNCTION: GAIN-PHASE CENTER: 60MHz SPAN:0Hz OSC:15dBm OUTPUT: SINGLE	Spec. Analyzer INPUT #2 to SINGLE OUTPUT START:1MHz STOP:500MHz ResBW:1MHz RefLevel:15dBm	60MHz amplitude and harmonics Spurious: 160, 220, 100MHz	
4	SWEEP: DC BIAS START:-40V STOP:40V NOP:10	Oscilloscope 10ms/DIV CH-A to TP9 dc coupled 5V/DIV TRIGGER:CH-A		
5	Same as 4	Oscilloscope 10ms/DIV CH-A to Hcur dc coupled 20V/DIV TRIGGER:CH-A		

A24 OUTPUT AMPLIFIER / A24 AI ATTENUATOR / POWER SPLITTER

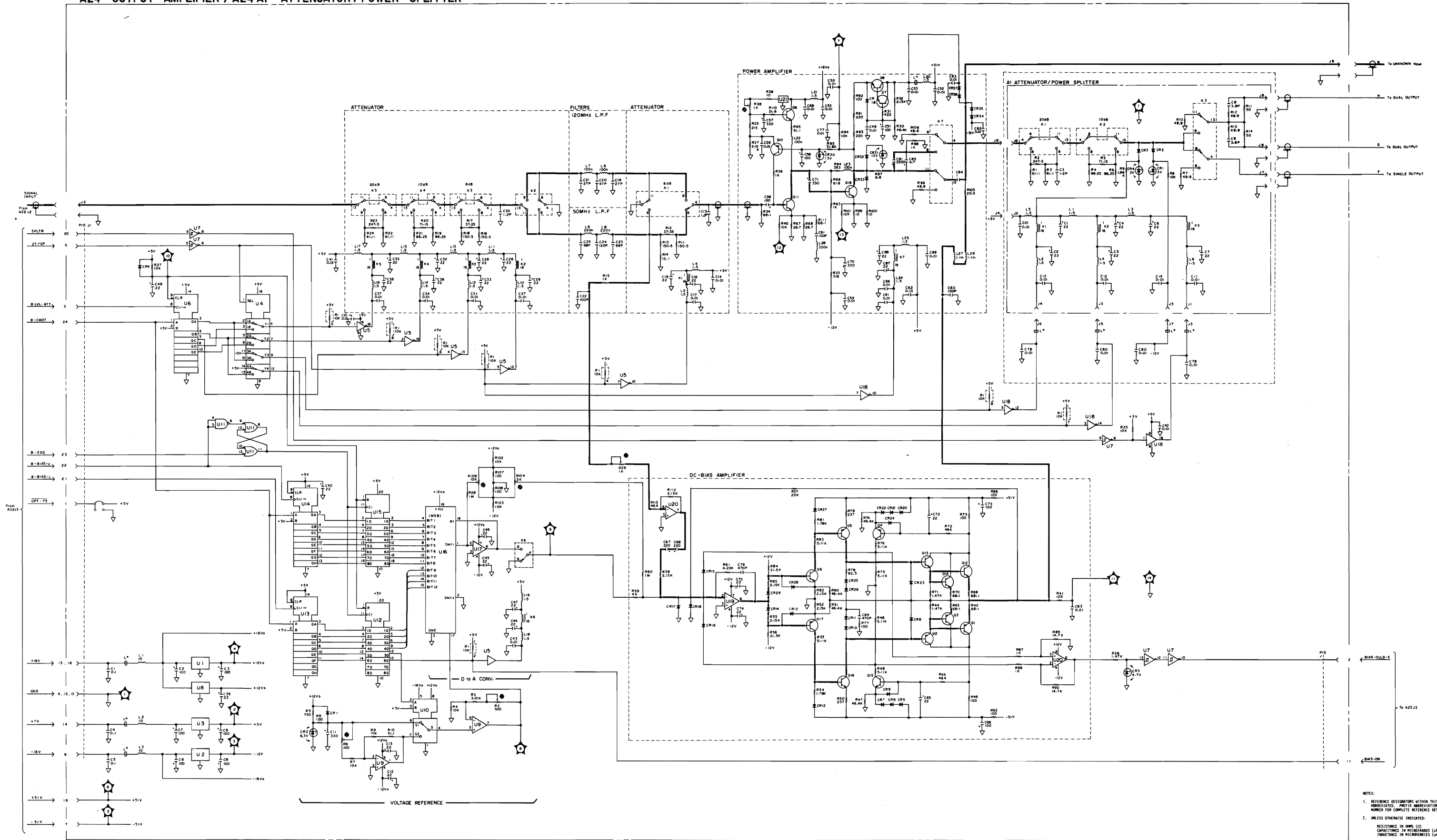

NOTES:
 1. REFERENCE DESIGNATORS WITHIN THIS ASSEMBLY ARE ABBREVIATED. PREFIX ABBREVIATION WITH ASSEMBLY NUMBER FOR COMPLETE REFERENCE DESIGNATOR.
 2. UNLESS OTHERWISE INDICATED:
 RESISTANCE IN OHMS (Ω)
 CAPACITANCE IN MICROFARADS (μF)
 INDUCTANCE IN MICROHENRIES (μH)

A24 Output Amplifier Schematic Diagram

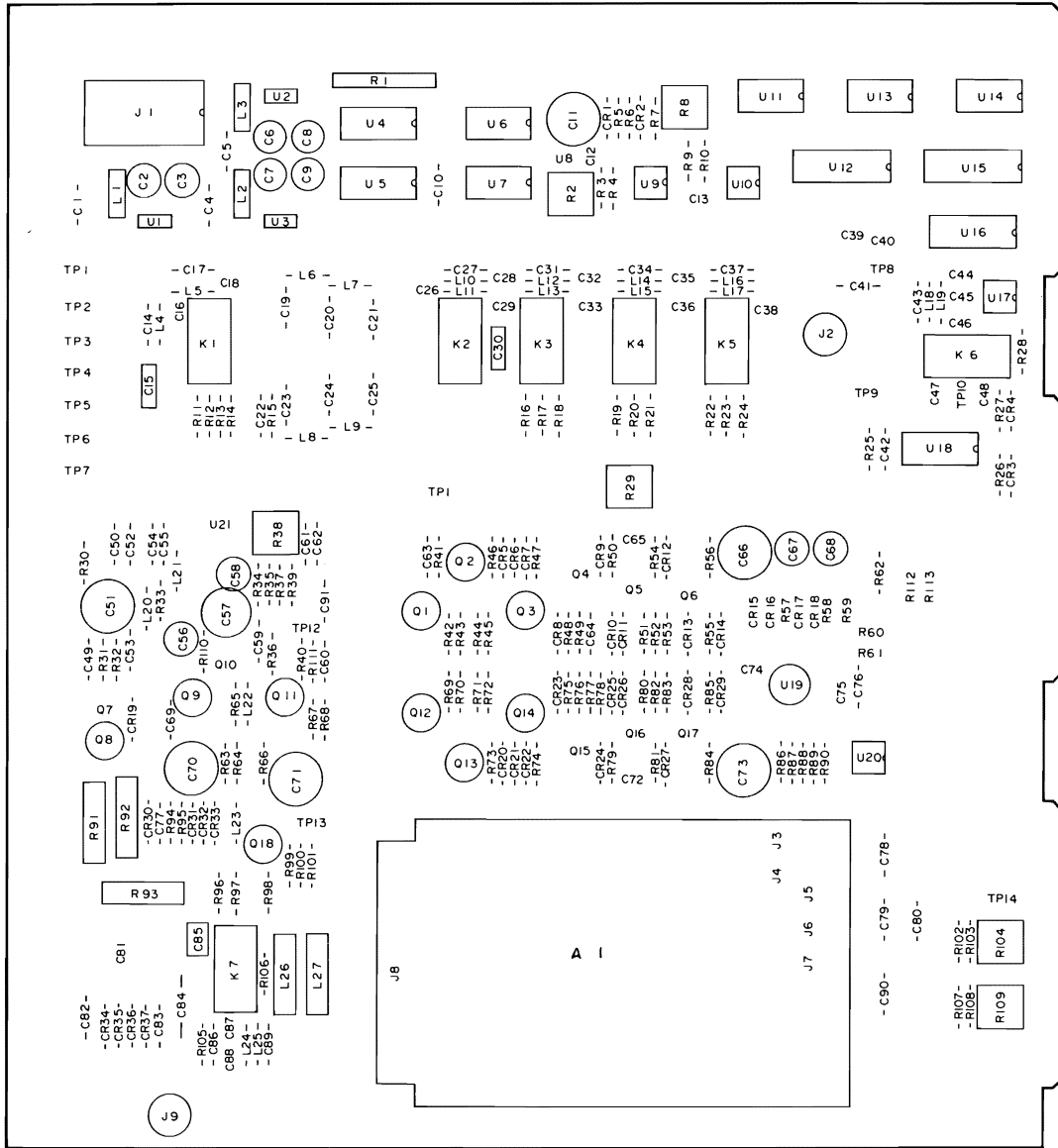

A34 Output Amplifier Component Locations

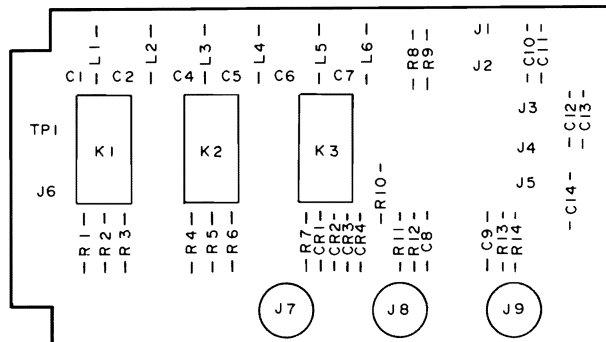

A34A1 Attenuator/Power Splitter Component Locations

A34 OUTPUT AMPLIFIER / A34 AI ATTENUATOR / POWER SPLITTER

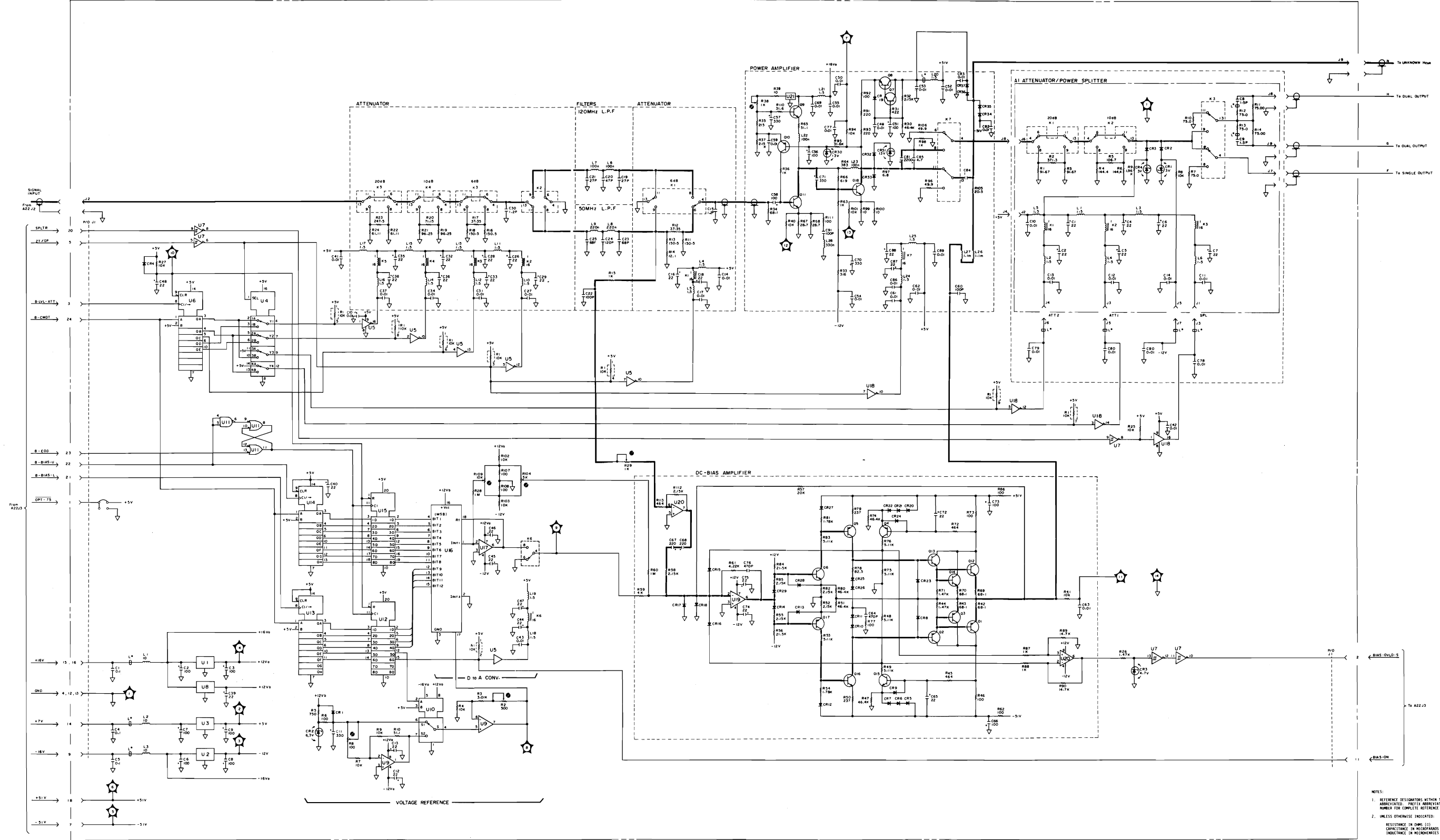

NOTES:
 1. REFERENCE DESIGNATORS WITHIN THIS ASSEMBLY ARE ABBREVIATED. PREFIX ABBREVIATION WITH ASSEMBLY NUMBER FOR COMPLETE REFERENCE DESIGNATOR.
 2. UNLESS OTHERWISE INDICATED:
 RESISTANCE IN OHMS (Ω)
 CAPACITANCE IN MICROFARADS (μF)
 INDUCTANCE IN MICROHENRIES (μH)

A34 Output Amplifier Schematic Diagram

A25 High Stability Oscillator Service Sheet

This board is installed only in 4194As which have Option 001. This board contains a dc voltage regulator and a crystal oven oscillator module.

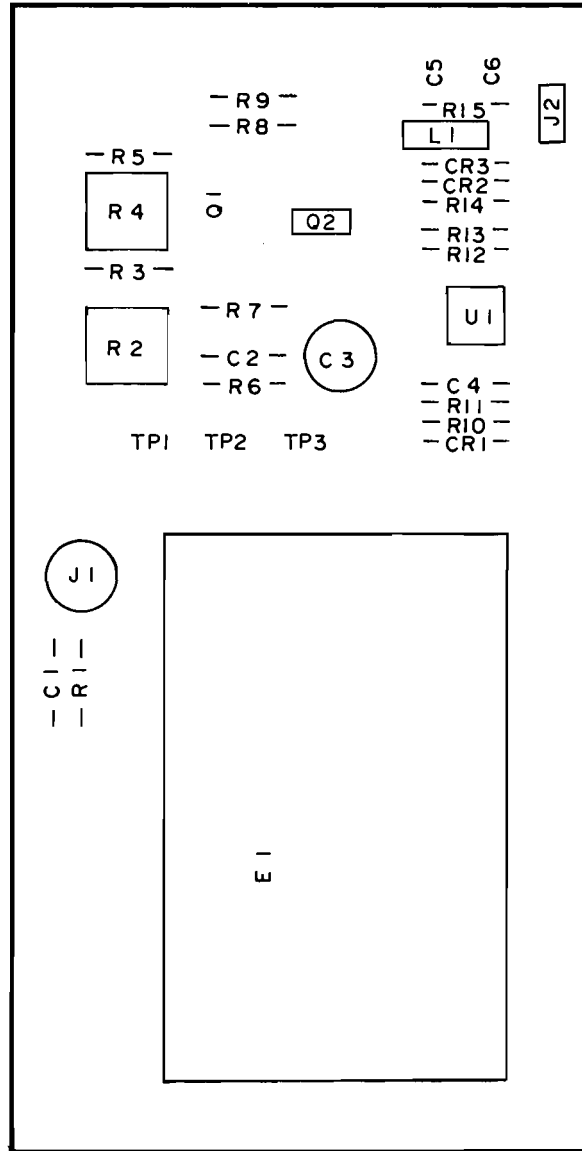

A25 HIGH STABILITY OSCILLATOR

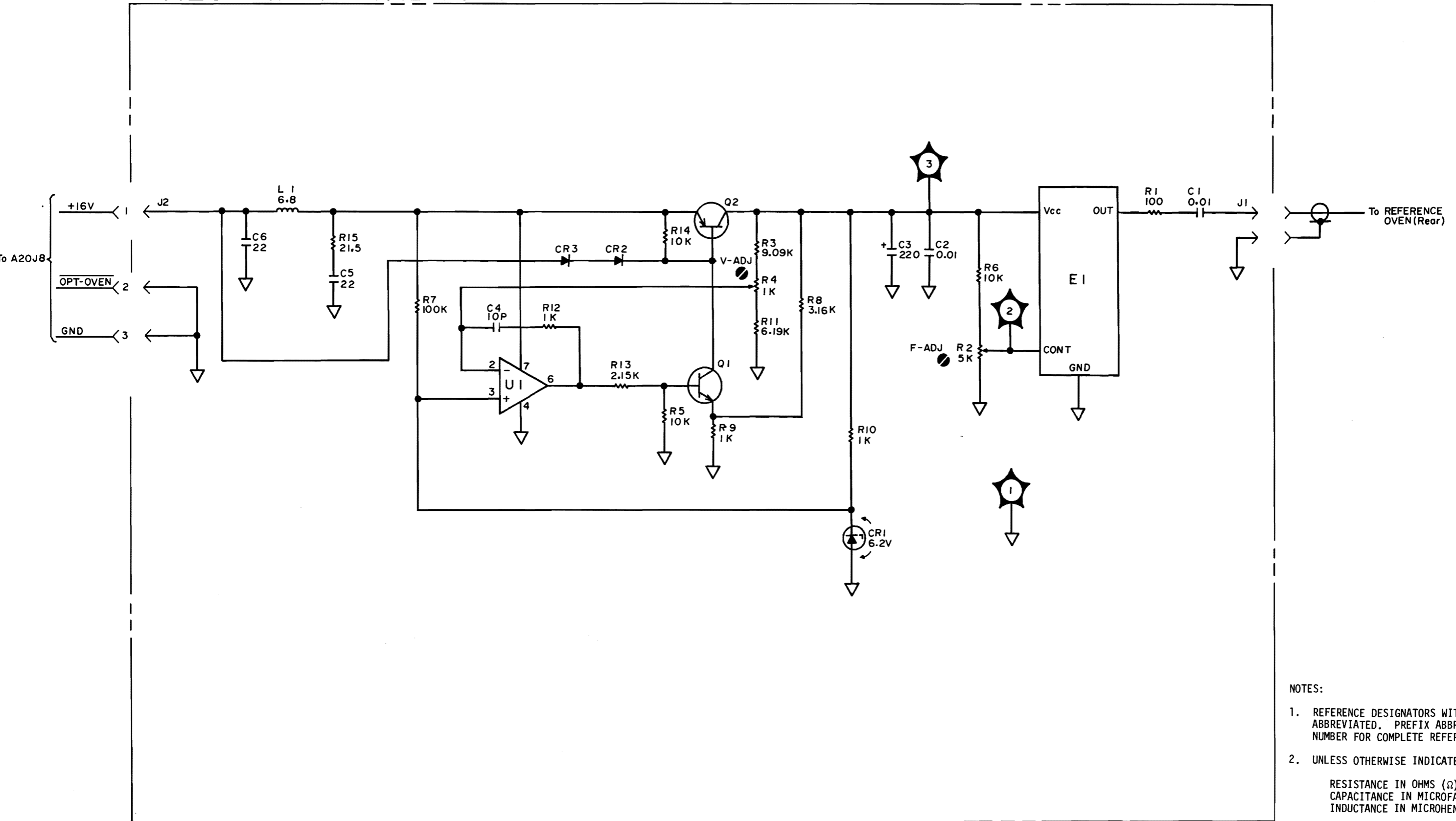

- NOTES:
1. REFERENCE DESIGNATORS WITHIN THIS ASSEMBLY ARE ABBREVIATED. PREFIX ABBREVIATION WITH ASSEMBLY NUMBER FOR COMPLETE REFERENCE DESIGNATOR.
 2. UNLESS OTHERWISE INDICATED:
 RESISTANCE IN OHMS (Ω)
 CAPACITANCE IN MICROFARADS (μF)
 INDUCTANCE IN MICROHENRIES (μH)

A25 High Stability Oscillator Schematic Diagram

A26 Measurement Unit Keyboard Service Sheet

The A26 board contains the OUTPUT select key, INPUT IMPEDANCE and ATTENUATION select keys and their indicators, CABLE LENGTH switch, BIAS ON and OVERLOAD lamps and drivers. When a select key is pressed or the CABLE LENGTH setting is changed, an interrupt signal is generated to notify the CPU that a control setting in the measurement unit has been changed.

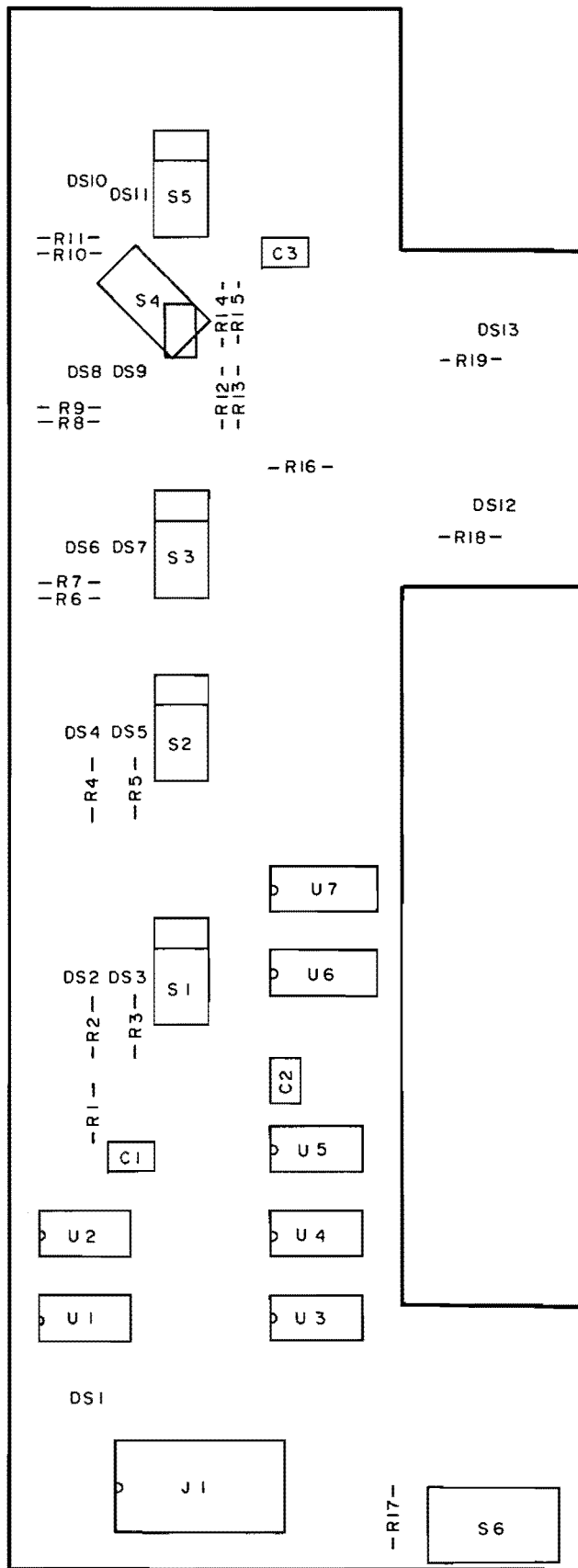

A26 Measurement Unit Keyboard Component Locations
8-168

A26 MEASUREMENT UNIT KEYBOARD

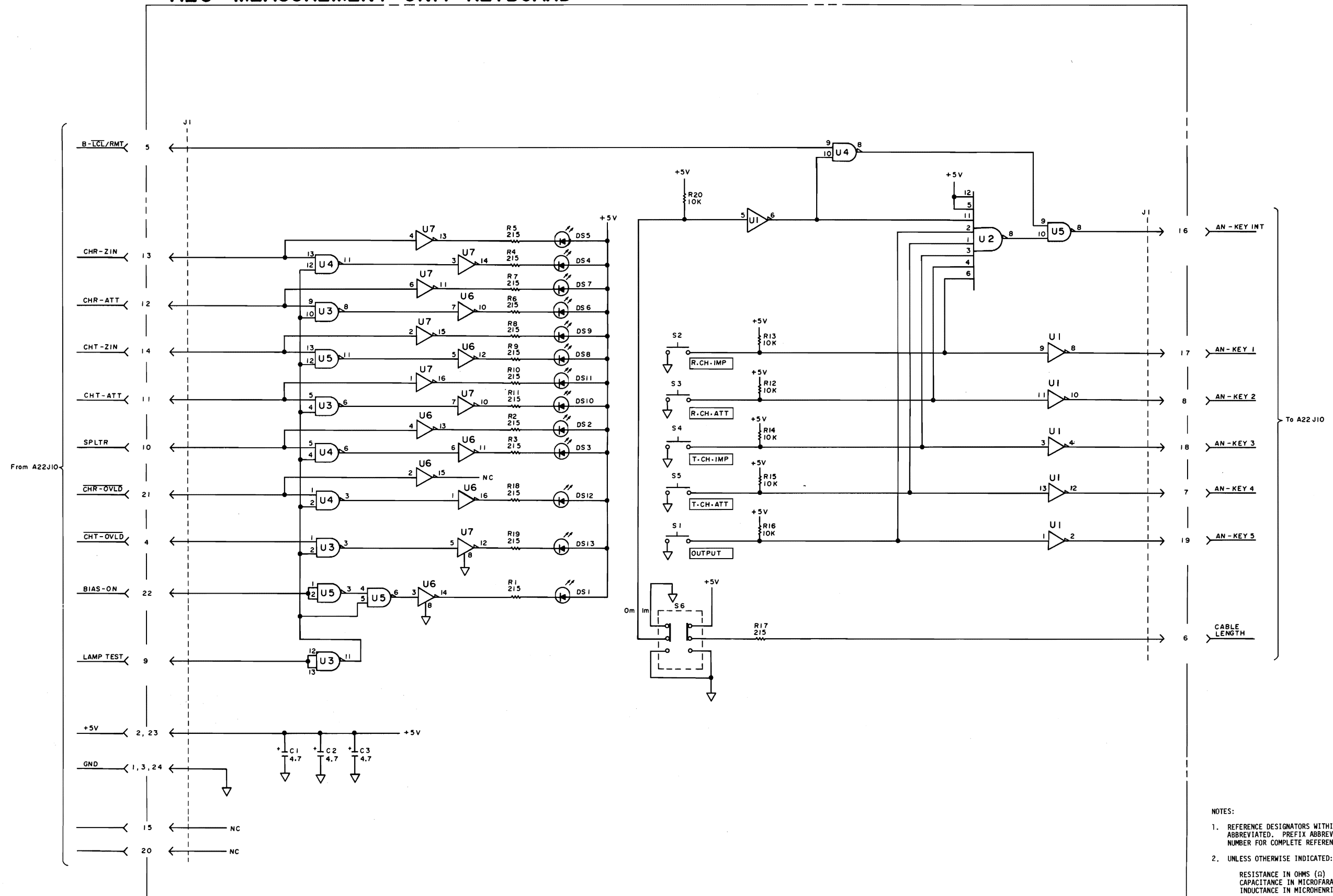

NOTES:
 1. REFERENCE DESIGNATORS WITHIN THIS ASSEMBLY ARE ABBREVIATED. PREFIX ABBREVIATION WITH ASSEMBLY NUMBER FOR COMPLETE REFERENCE DESIGNATOR.
 2. UNLESS OTHERWISE INDICATED:
 RESISTANCE IN OHMS (Ω)
 CAPACITANCE IN MICROFARADS (μ F)
 INDUCTANCE IN MICROHENRIES (μ H)

A26 Measurement Unit Keyboard Schematic Diagram